

# W Collection

## W103033PELAUS

### 15-PLACE POWER CLEAN INTEGRATED DISHWASHER

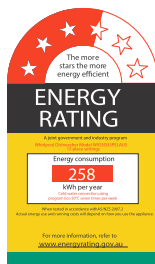

### TECHNICAL SPECIFICATIONS

MAIN COLOUR FINISH	N/A (fully integrated)
DIMENSIONS	W 598mm x H 820mm x D 555mm
CAPACITY	15 Place
DISPLAY	Electronic
BASKETS	2 + Flexible Cutlery Drawer
PROGRAMS (10 + 2)	Eco 6th SENSE Intensive Mixed Fast Wash & Dry Crystals Fast Wash 30' Silent Sanitizing PreWash Self Clean
FEATURES	Wash Indicator LED Power Clean 6th SENSE Cutlery Drawer Multizone Super Silent Self Clean NaturalDry Turbo
WATER CONNECTION	Hot or Cold
SAFETY	Aquastop + overflow
TIMER	Delay 1-12 Hours
NOISE	43 (dBA)
WATER USAGE	13.5L per wash (WELS Reg#D02502)
WATER RATING	4.5 stars
ENERGY CONSUMPTION	258 kWh/yr
ENERGY RATING	3.5 stars
ELECTRICAL CORD LENGTH	130cm
ELECTRICAL CONNECTION RATING	1900W
CURRENT	10A
VOLTAGE	220-240V
FREQUENCY	50Hz
INLET HOSE LENGTH	155cm
OUTLET HOSE LENGTH	150cm
NET WEIGHT	37.5 Kg
WARRANTY	Five years parts and labour
COUNTRY OF ORIGIN	Manufactured in Europe

### FEATURES & BENEFITS



#### Power Clean

Thanks to the additional power jets, this option provides a more intensive and powerful wash in the lower rack, in the specific area. This option is recommended for washing pots and casserole dishes.



#### 6<sup>TH</sup> SENSE

6<sup>th</sup> SENSE automatically detects and monitors the level of soil thanks to a smart sensor and adapts the cycle parameters and program settings accordingly. You will always get perfectly clean dishes with no effort, saving time and water.



#### MULTIZONE

If you do not have many dishes to be washed, a half load may be used to save water, energy and detergent.



#### SPACE MANAGEMENT

15 place settings with 3 racks provide room for even the biggest family.



#### TURBO

This option can be used to reduce the duration of the main programs while maintaining the same washing and drying performance levels.



#### Natural Dry

A convection drying system which automatically opens the door during/after drying phase to ensure exceptional drying performance. Door opens at the temperature that is safe to your kitchen furniture, so the door will not be opened when the option of TURBO is on.

DISTRIBUTED BY ARISIT PTY LTD

40-50 Mark Anthony Drive,

Dandenong South VIC 3175

Ph: 1300 762 219

Fax: 03 9768 0838

Website: [www.arisit.com](http://www.arisit.com)

1A Howe Street,

Newton, Auckland NZ 1145

Ph: (09) 306 1020

Website: [www.arisit.com](http://www.arisit.com)

# WI0303PELAUS

15-PLACE POWER CLEAN INTEGRATED DISHWASHER

## PRODUCT DIMENSION DIAGRAM

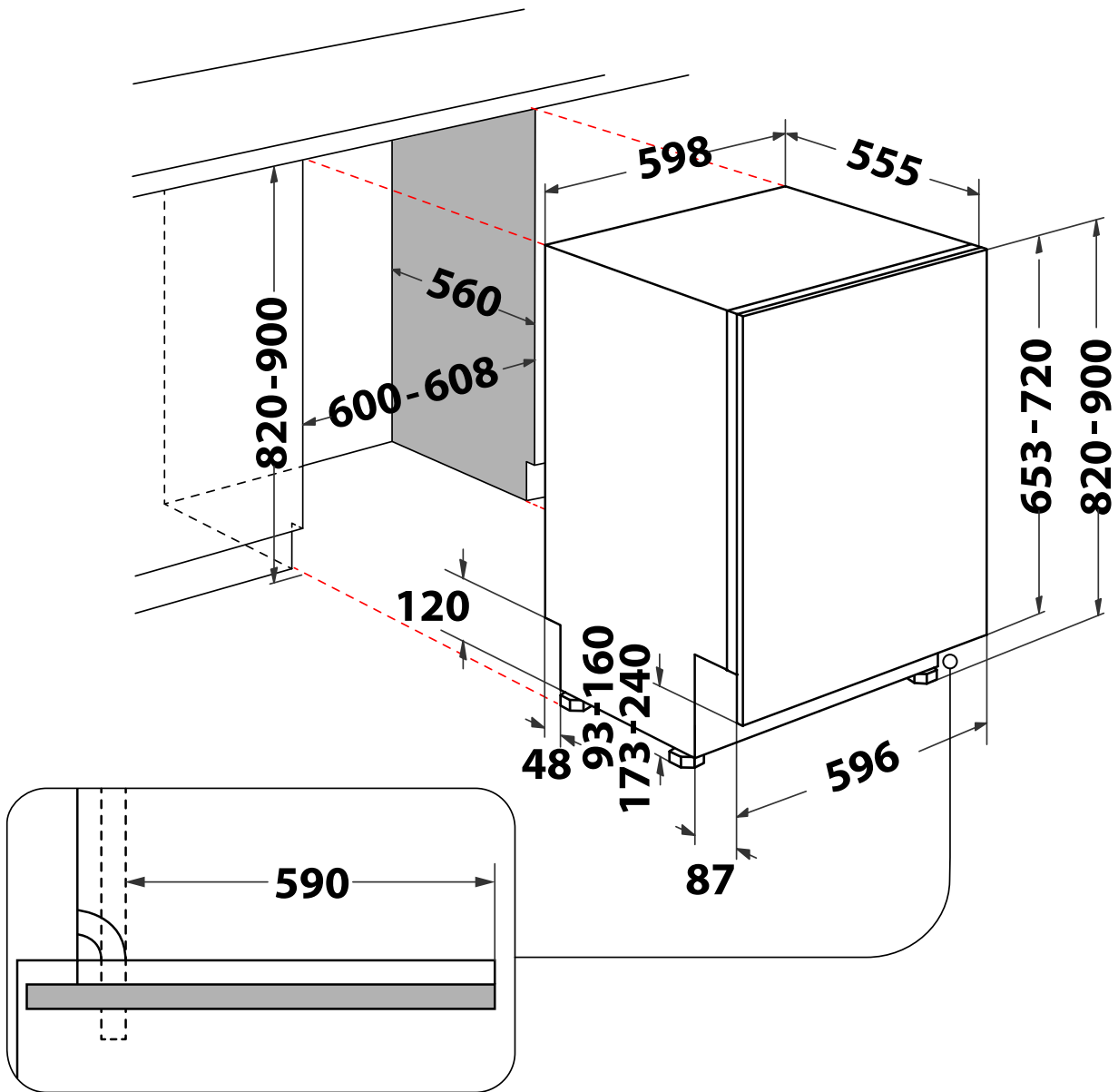

DISTRIBUTED BY ARISIT PTY LTD

40-50 Mark Anthony Drive,  
Dandenong South VIC 3175

Ph: 1300 762 219

Fax: 03 9768 0838

Website: [www.arisit.com](http://www.arisit.com)

1A Howe Street,  
Newton, Auckland NZ 1145

Ph: (09) 306 1020

Website: [www.arisit.com](http://www.arisit.com)