



ESSENTIAL SERIES

GENERAL PURPOSE LED BULBS

KT-LED7.5R20-9XX

REPLACEMENT LAMP

DESCRIPTION

7.5W R20 Lamp | 2700–5000K | >90 CRI | Standard Flood



Enclosed
Fixture Rated



RoHS
Compliant

3 YEAR
WARRANTY



LAMP TYPE: R20
BASE TYPE: E26 (Medium)
WATTAGE: 7.5W
COLOR TEMPERATURE: 2700–5000K
COLOR RENDERING INDEX (CRI): >90
WARRANTY: 3 Years
RATED LIFE: L70 (15,000 Hours)



TYPICAL APPLICATIONS

- Recessed Downlights
- Track Lighting
- Surface Mount Ceiling Fixtures

PRODUCT FEATURES

- Energy Efficient, 80%+ Energy Savings over Legacy Equivalents
- Lower Heat Generation than Legacy Equivalents
- PF >0.90
- Complies with Part 15 of FCC
- Smooth diffused lens for comfortable glare free performance
- HiCRI LED's offer enhanced color rendering vs 80 CRI LED's, providing ideal clarity, representation, and uniformity of illuminated area/objects
- Rated for use in damp and wet locations
- Operating temperature range –13°F/–25°C to 104°F/40°C
- Long Life minimizes replacement and maintenance costs
- ANSI compliant construction ensures fitment for intended applications
- Meets Energy Star requirements
- UL Listed
- Smooth, uniform dimming
- Durable Plastic housing lowers the risk for breakage

ELECTRICAL AND PERFORMANCE SPECIFICATIONS

Keystone Catalog Number	Description	Color Temp	Input Voltage	Rated Lamp Wattage	Legacy Equivalent Wattage	Base Type	Lumens	CRI	Light Distribution	Dimmable	Efficacy
KT-LED7.5R20-927	R20 bulb. Standard flood, dimmable	2700K	120V	7.5W	50W halogen	E26	525	>90	110°	Yes	70 lm/W
KT-LED7.5R20-930	R20 bulb. Standard flood, dimmable	3000K	120V	7.5W	50W halogen	E26	525	>90	110°	Yes	70 lm/W
KT-LED7.5R20-940	R20 bulb. Standard flood, dimmable	4000K	120V	7.5W	50W halogen	E26	525	>90	110°	Yes	70 lm/W
KT-LED7.5R20-950	R20 bulb. Standard flood, dimmable	5000K	120V	7.5W	50W halogen	E26	525	>90	110°	Yes	70 lm/W

KT-LED7.5R20-9XX

REPLACEMENT LAMP

PHYSICAL CHARACTERISTICS

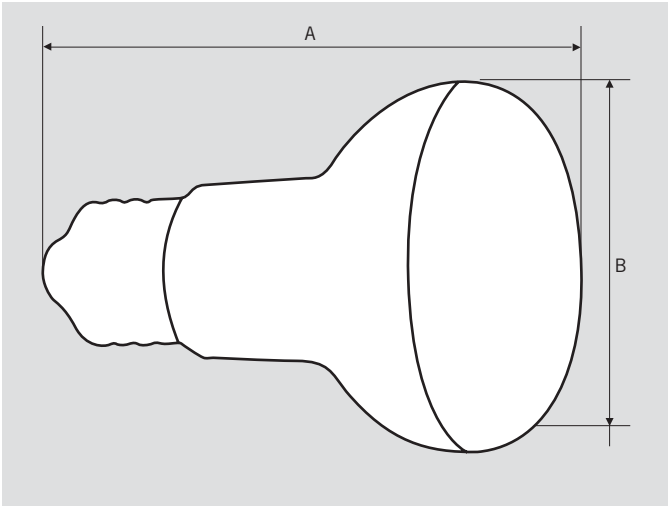

PACKAGING

Carton Quantity	60 pcs
Carton Dimensions	8.54" × 13.46" × 16.50"
Carton Weight	7.9 lbs

LAMP DIMENSIONS

A (Length)	3.75"
B (Diameter)	2.48"

BASE TYPE: E26 (Medium)

ORDERING INFORMATION

ORDER CODE	CARTON QUANTITY	ENERGY STAR UNIQUE ID	EASY CODE	UPC
KT-LED7.5R20-927	60 pcs	2350489	MBU-07	843654126036
KT-LED7.5R20-930	60 pcs	2350490	FDM-82	843654126043
KT-LED7.5R20-940	60 pcs	2350491	MAX-83	843654126050
KT-LED7.5R20-950	60 pcs	2350492	SHP-50	843654126067

CATALOG NUMBER BREAKDOWN

KT-LED7.5R20-9XX

1 2 3 4 5 6

- 1 Keystone Technologies
- 2 LED Lamp
- 3 Wattage
- 4 Lamp Shape
- 5 900 Series
- 6 Color Temperature