

## VIFRONT/MAX-3/FRONTO

VIFRONT SV(P/PU)-01/05, SV-02  
SYSTEM MAX-3 SX(P/PU)-05  
FRONTO SVP(U)-06, SXP(U)-06





EN

- Thank you for choosing VOX products. If you follow all the rules stated in the installation manual, the product will serve you for a long time, which is confirmed by the warranty available on the manufacturer's website.
- Vinyl siding is a construction material being environmentally friendly, fire resistant, weatherproof, very practical and durable, intended for external decoration of all types of buildings.
- The MAX-3 system is an advanced façade system. The use of the innovative three-layer MAX-3 technology made it possible to create a product that can be used in extreme conditions. MAX-3 panels are characterised by high resistance to mechanical damage, which until now was a property shown only by metal siding. In mechanical damage resistance tests, the MAX-3 results are 3 times higher than the standards for vinyl siding. The MAX-3 system also shows low linear expansion, which provides high resistance to high and low temperatures. At the same time, unlike metal sidings, the MAX-3 system is convenient and easy to work with and install. It does not corrode or peel during use, and therefore does not require special maintenance or painting.
- The FRONTO slat panel is available in 2 variants: a two-layer panel made in the co-extrusion technology and a three-layer panel made in the Max-3 technology. FRONTO can be installed on walls and as a ceiling finish with a maximum length of 2.5 m. For lengths above 2.5 m, it is necessary to use the SV(\*)-18 trim, which will provide an additional expansion joint.
- SV(\*)SX(\*)-01/02 profiles can be installed horizontally, while SV(\*)SX(\*)-05/06 profiles can be installed both horizontally and vertically.
- The products are manufactured using the coextrusion technology, which allows for more effective use of expensive material constituents that significantly improve its quality. Visually, the profile is composed of two layers. The top layer features a specific colour and is responsible for the weather resistance, while the bottom layer ensures stability and resistance to mechanical damage.
- Products should be stored in covered spaces, beyond heating equipment and direct sunlight, at a temperature not higher than 60°C. In terms securing profiles against contamination, deformation and mechanical damage. The products should be stored on shelves or pallets with a length not less than the length of a package. It is not allowed to leave the ends of the package without support and laying more than 10-12 packs of one another.
- The product should be transported in a horizontal position, at a temperature not exceeding 60°C.
- Unpack the product and compare the colours before installation. Minimum shade differences are admissible. After installation, complaints regarding differences in panel colours will not be accepted.
- Machining of the profiles should be performed using conventional woodworking tools for cutting or drilling. Use fine toothed saws; mechanic tools for machining should be used with the same or higher speeds as for woodworking.
- A natural and immanent feature of PVC is the change of dimensions resulting from different temperatures. The profiles may change their length by 0.7mm at a 1m section, for each 10°C of temperature difference.
- The recommended ambient temperature during installation is between 0°C and 30°C. Prior to installation, the profiles should be seasoned for 2-3 hours at the installation site so that the profile temperature adjusts to the ambient temperature.
- For professional installation, the permissible installation temperature is: -15°C to 40°C.
- Cutting the profiles should be preferably performed using an angle grinder, to prevent cracks. During cutting, protect your eyes with safety goggles.
- Maintain appropriate ventilation from the bottom (approx. 150 mm from the ground) and top side of the wall (approx. 20 mm). Heat accumulation is a natural feature of the profiles. Failure to maintain appropriate air gap may cause thermal degradation of the material.
- Adequate expansion spaces must be maintained. Detailed expansion joint dimensions depending on the installation temperature and the length of the profile are presented in Table 3.
- Do not modify the product by machining its surface or covering it with a layer of another material.
- If any visible flaws emerge or irregularities are detected, report them immediately to the seller before installation.
- Observe all the rules indicated in the instruction for installations and use.

INSTALLATION

- The bearing structure may be made of wooden battens or metal profiles mounted directly on the walls. Both the wooden battens and metal profiles should be adjusted with a level, so they form an even surface; use wedges to align the battens, if necessary.
- Wooden battens should be made of good quality wood, without knots, with a humidity of 15-18%, properly impregnated, with dimensions 30x22mm, 30x40mm, or 30x50mm, the size of the battens depends on the height and ambient temperature. Information useful in choosing the size of the batten is presented in Fig. 1.4 and in Table 2.
- For metal construction, we use as standard galvanised profiles with UW/CW 75 cross-section, width 50,4 lm. The height dimension of the profiles depends on the height and ambient temperature, analogous to the size of wooden battens. Both wooden and metal battens are mounted at a distance of max. 40 cm, counting from the centre of the battens. The permitted installation on a metal structure assumes the use of hollow profiles, bearing in mind that appropriate heights have to be maintained, as in the case of a wooden substructure.
- When installing the panels, never tighten the screw to the end (so the head directly touches the panel surface), as this may limit the possibility of expansion/contraction. Maintain a small gap between the panel surface and the bottom plane of the screw head, so it is possible to move the panel horizontally after it is screwed to the battens.
- During the installation of panels and fixing elements, the bolt should be screwed in the centre of the mounting hole. Mounting directly through the profile surface is not allowed.

INFORMATION FOR USE

Table 1

Vinyl Siding SVP/SVPU/SXP/SXPU-01/02/05/06: (Nature) 4GJ					Vinyl siding S/SX-01/02/05/06: (Unicolor) 8GJ				
	group 1	group 2	group 3	group 4		group 1	group 2	group 3	group 4
years	2	1.5	1	6 months	years	4	3	2	18 months
months	24	18	12		months	48	36	24	

Table 2

Group 1	Norway (NO), Sweden (SE), Finland (FI), England (GB-ENG), Ireland (IE), Denmark (DK), Germany (DE) Estonia (EE), Lithuania (LT), Belgium (BE), Belarus (BY), Latvia (LV), Luxembourg (LU), Netherlands (NL), Poland (PL), Russia (Europe) (RU), Czechia (CZ), France (north of parallel 45°N) (FR), Slovakia (SK), Ukraine (north of parallel 47°N) (UA), New Zealand (NZ)
Group 2	France (south of parallel 45°N excluding the Riviera) (FR), Switzerland (CH), Austria (AT), Hungary (HU), Romania (RO), Moldova (MD), Ukraine (south of parallel 47°N) (UA), Bulgaria (BG), Serbia (RS), Bosnia (BA)
Group 3	Italy (IT), Greece (GR), North Macedonia (MK), Croatia (HR), Montenegro (ME), Turkey (TR), France (Riviera) (FR), Monaco (MC), Canada (CA), Spain (ES), Israel (IL), United States (US)
Group 4	India (IN), Sri Lanka (LK), Kenya (KE), Egypt (EG), Libya (LY), Algeria (DZ), Morocco (MA), Brazil (BR), Australia (AU)

- During product use, colour changes due to solar radiation may occur in the time specified in Table 1, depending on the geographical location of the installed product (Table 2), not exceeding grey scale step 3, per EN 20105-A02.
- Objects, plants, or buildings located in the vicinity of the product, including ones in direct contact with the product, may cause uneven discolouration of the product.

CLEANING AND MAINTENANCE

- Panels and trims can be cleaned from time to time with a household detergent solution at a temperature of max. 40°C. The product should be protected against mould and harmful chemicals. Do not use solvents and similar aggressive and corrosive liquids. Flush the surface with clean water after washing.

DRAWINGS DESCRIPTIONS

1.1. Installation of horizontal battens. Adjust the spacing to used insulation. / 1.2. Laying of isolating layer. / 1.3. Laying of vapour barrier foil. / 1.4. Mounting of vertical battens. / 1.5. Installation of horizontal battens for vertical installation – in this case, the bottom battens can be spread more widely. / 2.1. Mounting ES brackets to a metal substructure. / 2.2. Insulating layer installation. / 2.3. Vapor barrier installation. / 2.4. Fixing metal profiles to ES brackets, bracket protruding parts must be bent out. / 2.5. In the corners, at intervals of 400 mm, should be installed additional auxiliary sheets for mounting corners. / 2.6. Use of the lower ventilation trim SV-11,5. / 2.7. Horizontal cross-section. A hollow profile can be used instead of a UW/CW profile. / 3.1. We mount SV-11,5 bottom ventilation trim first, followed by the vertical trims and finally the SV-11 starter trim. / 3.2. When installing bevels, install the SV-11.5 bottom ventilation trim first, followed by the vertical trims and finally the SV(\*)-15 starter trim. NOTE: Use the correct size screws. / 3.3. First panel is attached to SV-11 trim. / 3.4. Secure the panel with screws at designated mounting holes. Screws are to be placed in the middle of mounting hole. / 3.5. The dilatation spaces are to be maintained while mounting so that you can move panel (row of panels) horizontally. Every consecutive panel is attached to the edge of preceding one bending it slightly to fit it into a pocket of vertical strips. Mounting of inside corner SV(\*)-13 and outside corner SV(\*)-12. / 3.6. Connecting siding panels with the SV(\*)-18 connector. Analogous connection applies to vertical installation. / 3.7. Siding panels overlapping. Applies only to SV(\*)-01 / SV-02 panels. / 3.8. Panels are to be cut to required height with e.g. angle grinder. / 3.9-3.10. Mounting of last panel, previously cut to required length, by means of SV(\*)-15 and SV(\*)-14 trims and edges. / 4.1. Use of finishing trims at windows openings - lower part, with SV(\*)-12, SV(\*)-14 and SV(\*)-15 trims. Cutting of panels to required window opening size. Panel that was already cut to size is attached to the panel mounted below. Upper cut edge is inserted into previously mounted finishing trims, maintaining proper dilatation. / 4.2. Mounting of panels inside the window niche. / 4.3. Use of finishing trims at window openings - upper part of the window opening (SV(\*)-13, SV(\*)-15). / 4.4. Cutting of panels to required window opening size - upper part of the window opening. / **VERTICAL INSTALLATION:** 5.1. Vertical installation of SV(\*)-05/06 and SX(\*)-05/06 panels using SV(\*)-15, SV(\*)-14, SV(\*)-12, SV(\*)-11,5 finishing trims. / 5.2. Installing the first panel vertically. Cut off the first panel lock and place it in the SV(\*)-11 trim. Locking the panel with two screws on the second batten from the top. On each subsequent batten, the panel is mounted in a standard manner. / 5.3. Cutting the last panel. / 5.4. Installation of the panels in the corners. Cut off the first panel lock and place it in the SV(\*)-11 trim. The first panel entering the corner must be locked at the second batten from the top. / 5.5. Every consecutive panel is attached to the edge of preceding one. / 5.6. Installation of the last panel, cut to length, using SV(\*)-15 and SV(\*)-14. / **FINISHING THE CEILING RECESS:** 6.1. Mounting of battens in the ceiling recess. Spacing of horizontal battens max. 400 mm. Space the right-, left-side outer battens and the wall away from the edge depending on the type of side mounting. / 6.2. Mounting of the battens / sub-structures starts from the left side of the recess. For the horizontal arrangement of the panels see fig. 1.1 - 1.4. / 6.3. Mounting of the battens / sub-structures For vertical layouts of the panels see fig. 1.1 - 1.5. / 6.4. Start the mounting of the trims from the left-hand side. Left side, top with SV(\*)-15 trim. Bottom trim as for horizontal panel installation, see fig. 3.1. Left side for vertical panel installation SV(\*)-15 trim. / 6.5. Mounting of SV(\*)-15 trims: top, right-hand side. Mounting of the lower trims and corner as for the vertical installation of the panels, see Figures 5.1 - 5.4. / 6.6. Start the mounting of the panels from the ceiling, left-hand side. Either the cut-off panel lock or the SV -11 trim can be used to start the installation, depending on the width of the upper wooden batten. / 6.7. When mounting the upper panels, slide the ends into the resulting pocket between the sub-structure and the SV(\*)-15 trim installed in the sub-structure for vertical and upper mounting. / 6.8. The second stage of panel mounting starts from the left-hand side(2). In the horizontal arrangement, the last panel is inserted above the top panels. Remember to support the last panel against the SV-14 trim. Next, mount the panels vertically (3-4) according to the instructions from Fig. 5.2 - 5.5 (remember the additional panel support point in the SV(\*)-15 trim at the start and end of the SV(\*)-15 trim).

# PANELE I LISTWY WYKOŃCZENIOWE • FINISHING PANELS AND MOULDINGS

SV(P/PU)-01

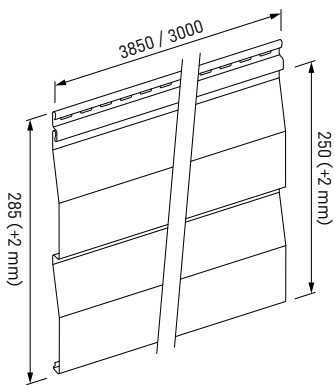

SV-02

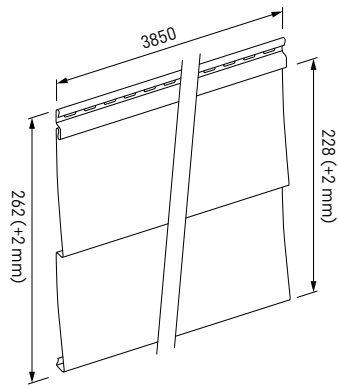

SV(P/PU)/SX(P/PU)-05

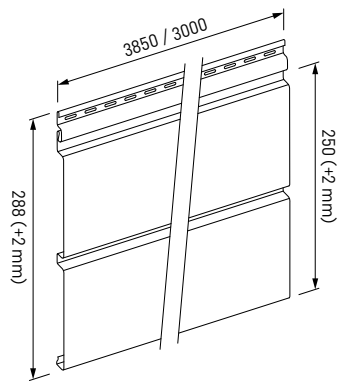

SV(P/PU)/SX(P/PU)-06

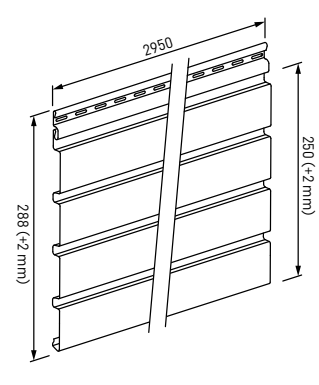

SV-11

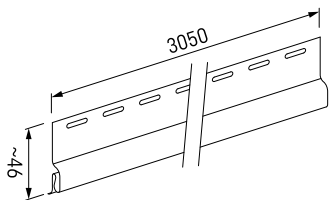

SV-11,5

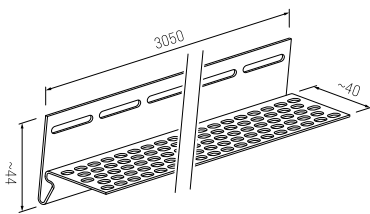

SV(P/PU)-12

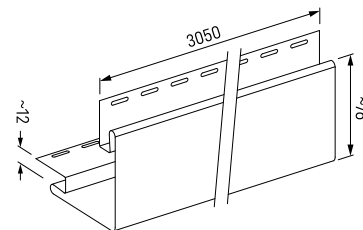

SV(P/PU)-13

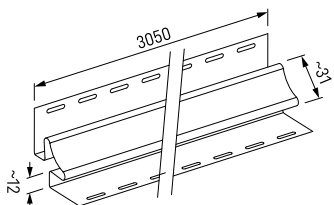

SV(P/PU)-14

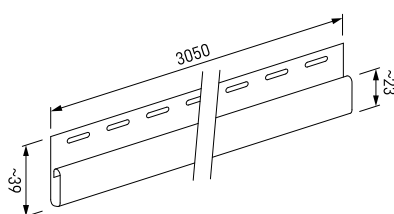

SV(P/PU)-15

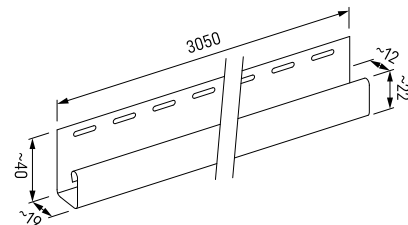

SV-16

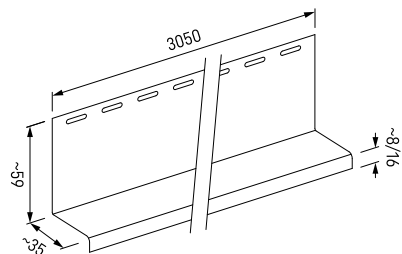

SV-17

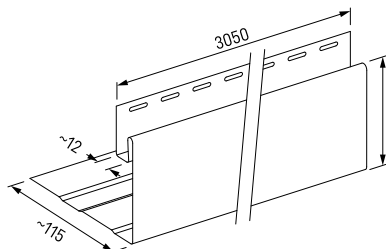

SV(P/PU)-18

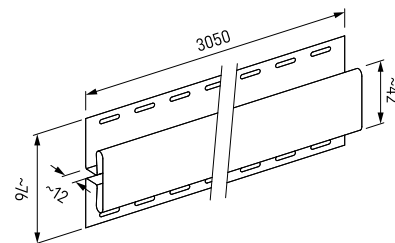

SV-19

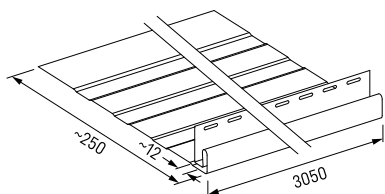

SV-20

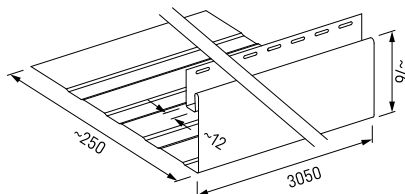

# NARZĘDZIA • TOOLS

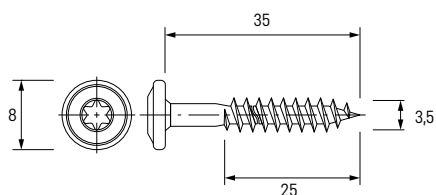
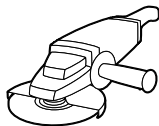
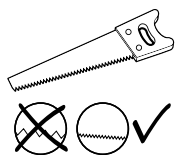
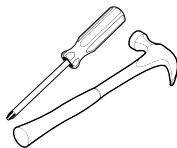
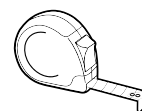
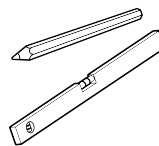
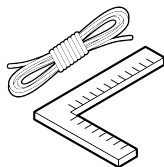

PL | wkręty do montażu na konstrukcji drewnianej  
EN | screws for installation on a wooden structure

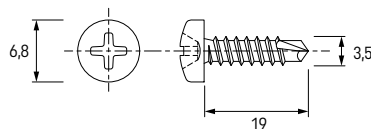

PL | wkręty do montażu na konstrukcji metalowej  
EN | screws for installation on a metal structure

# INFORMACJE O DYLATACJI • INFORMATION ABOUT THE EXPANSION

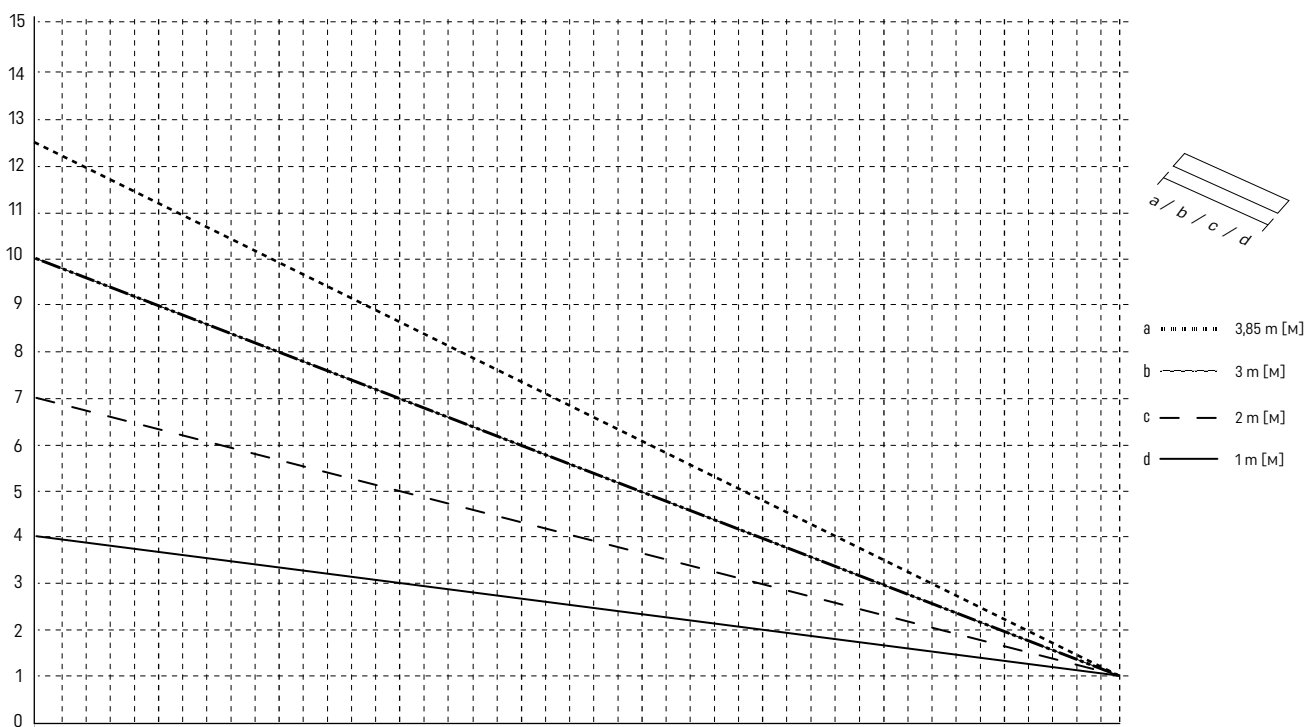

PL | Tabela 3  
EN | Table 3

# 1. KONSTRUKCJA NOŚNA DREWNIANA • WOODEN BEARING STRUCTURE

1.1

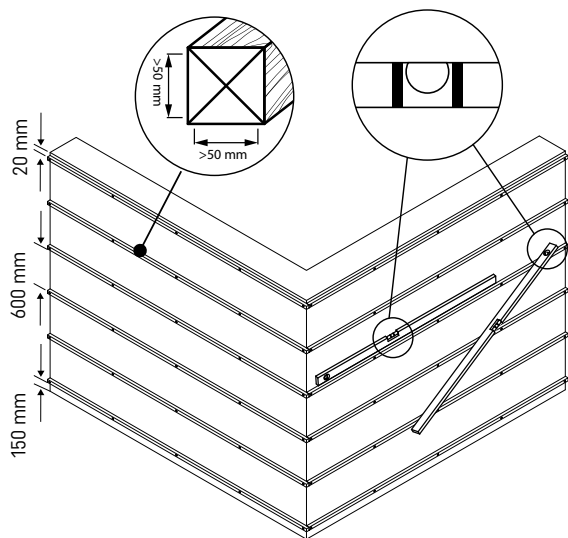

1.2

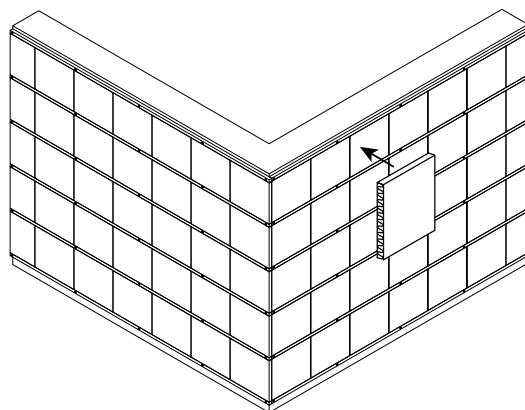

1.3

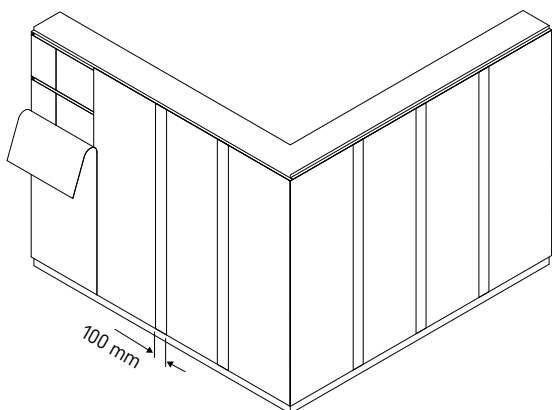

1.4

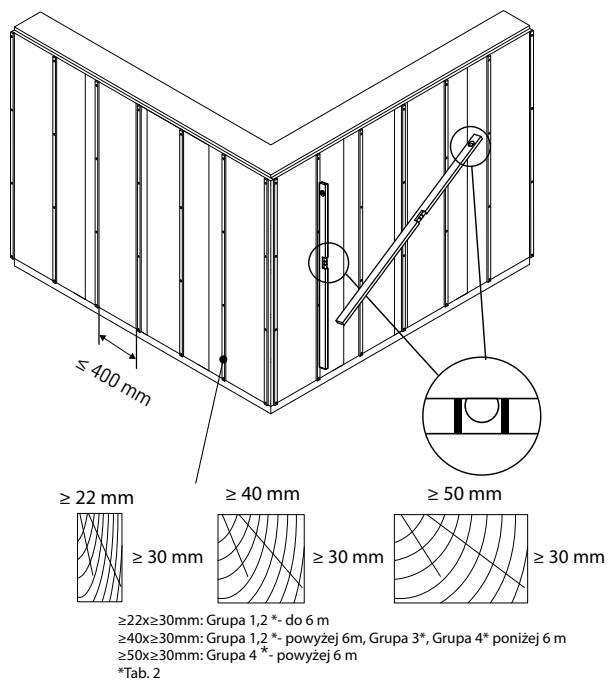

1.5

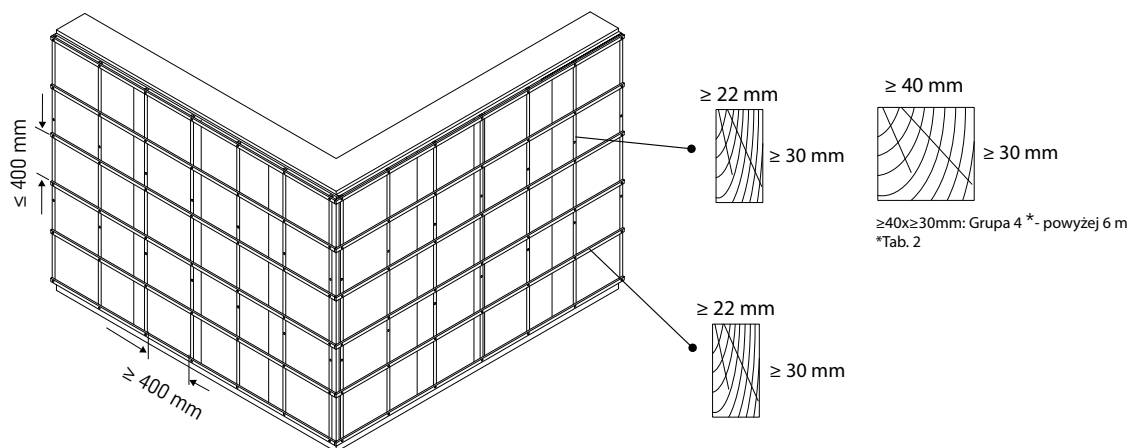

## 2. KONSTRUKCJA NOŚNA METALOWA • METAL BEARING STRUCTURE

2.1

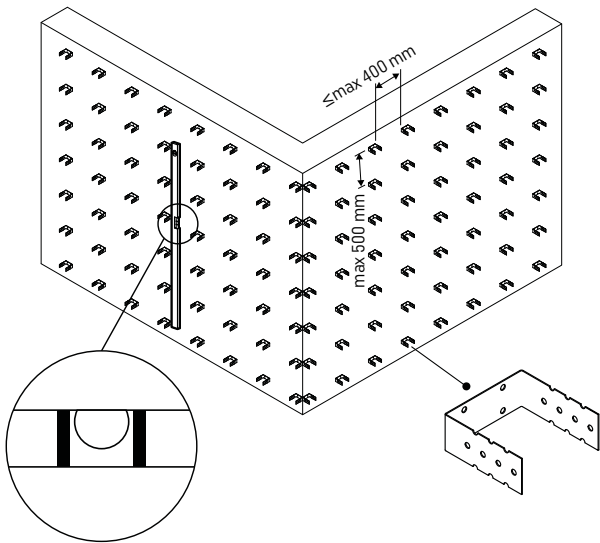

2.2

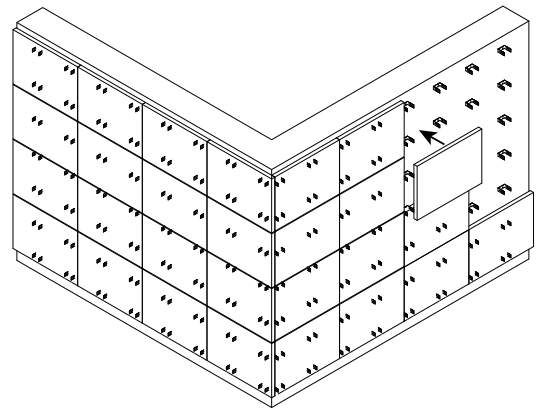

2.3

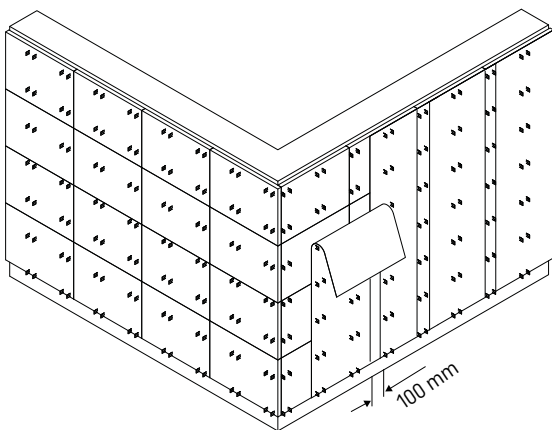

2.4

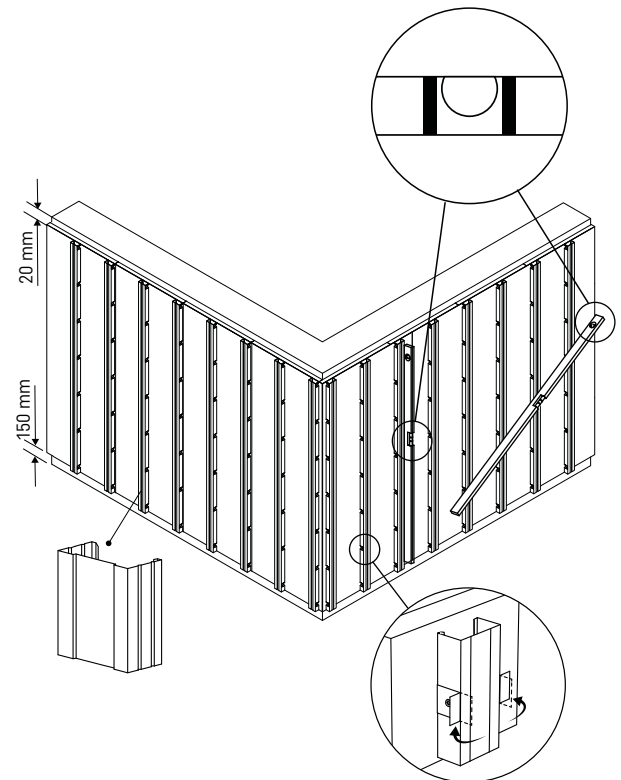

2.5

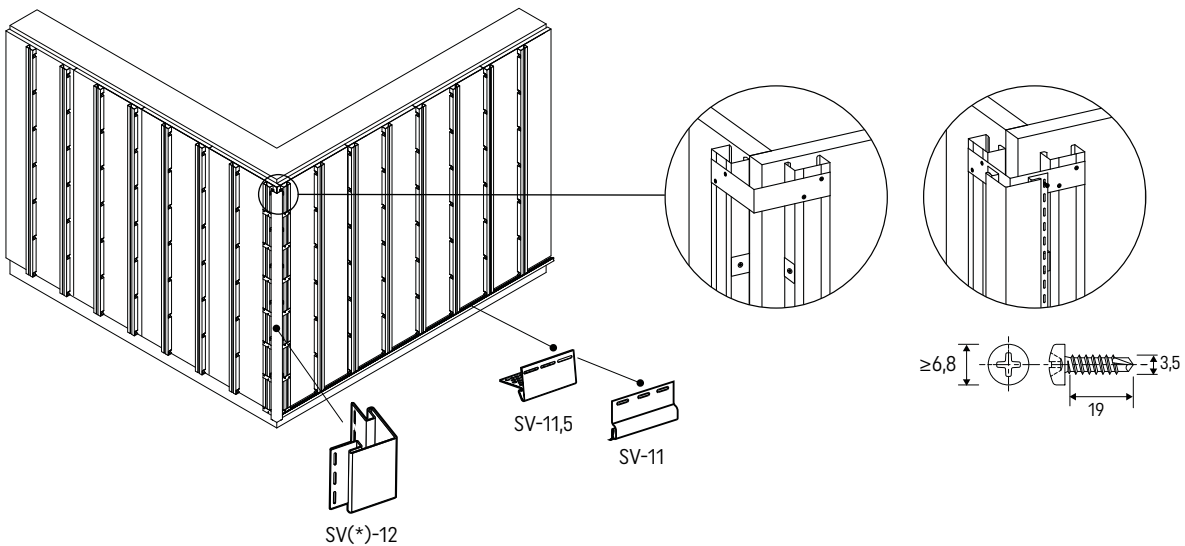

2.6

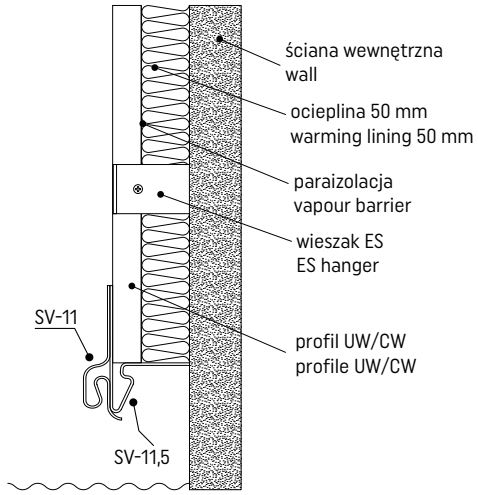

2.7

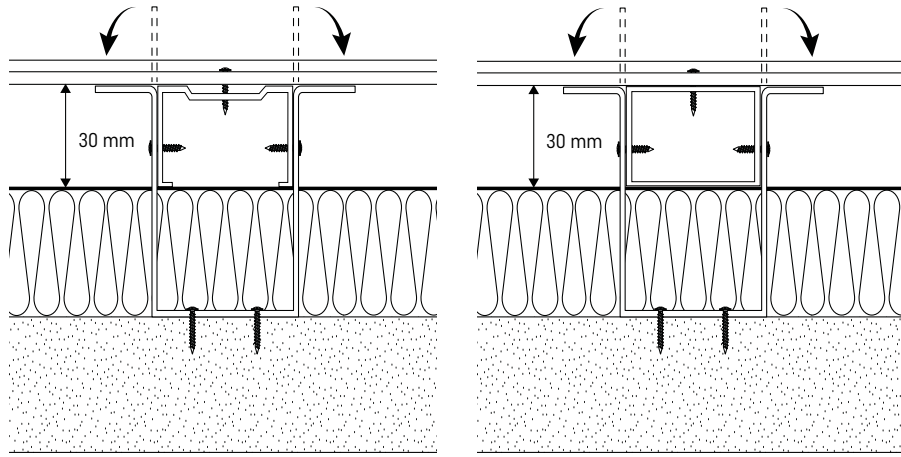

### 3. ETAPY MONTAŻU • INSTALLATION STAGES

3.1

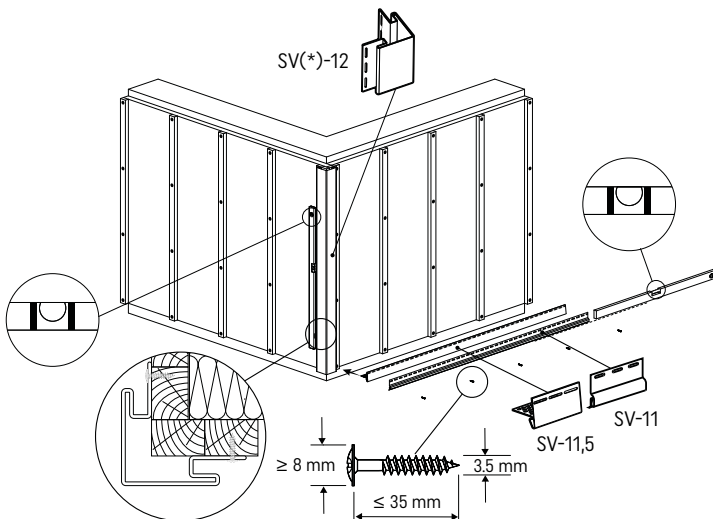

3.2

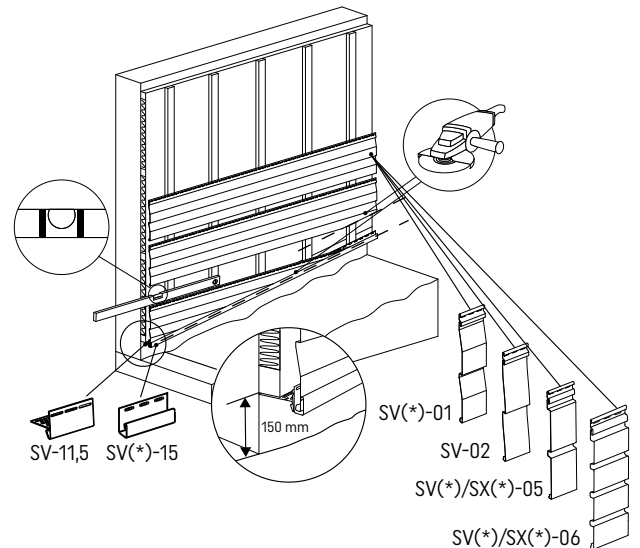



3.3

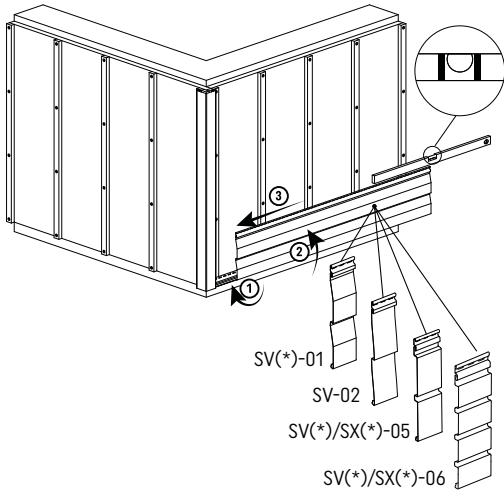

3.4

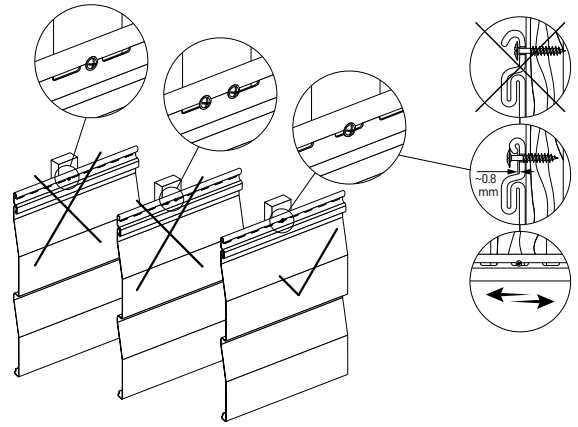

3.5

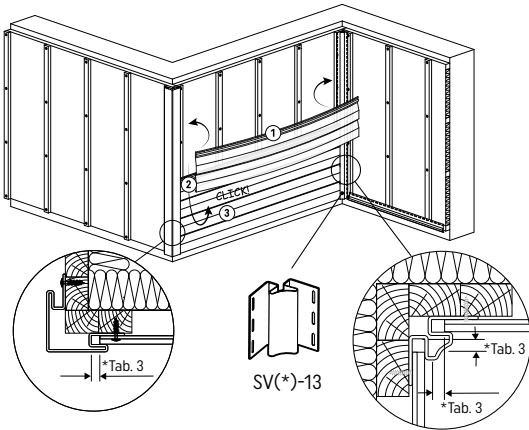

3.6

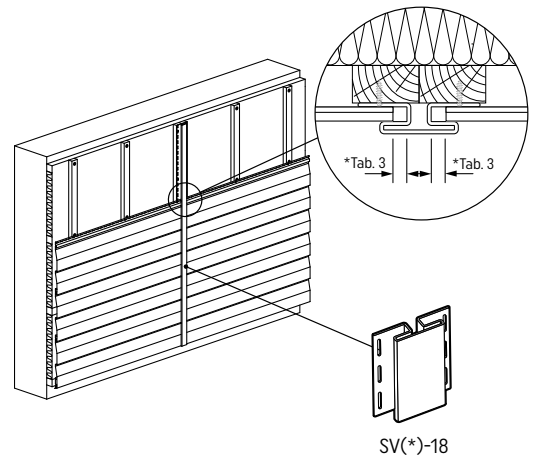

3.7

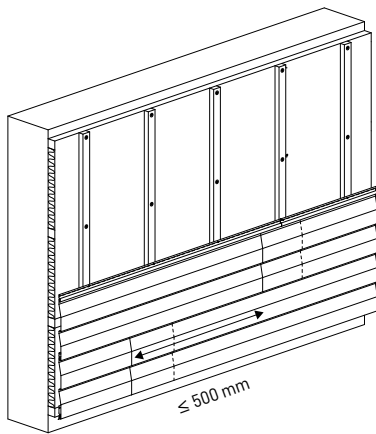

3.9-3.10

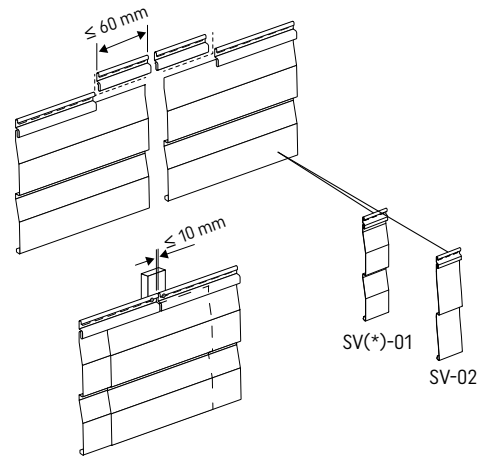

3.8

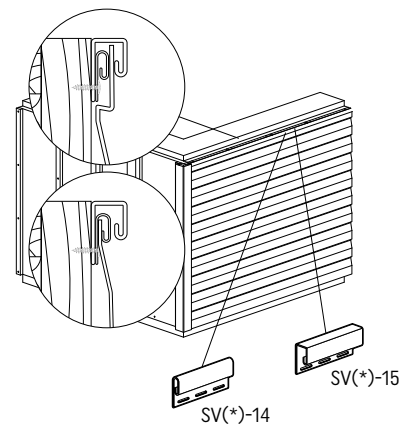
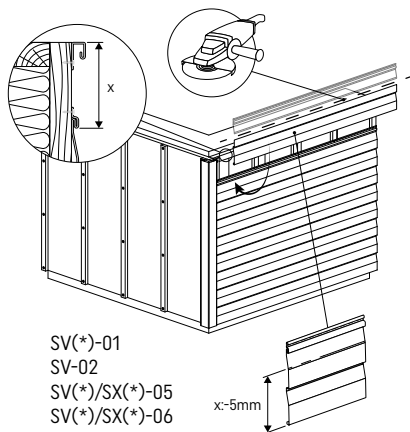

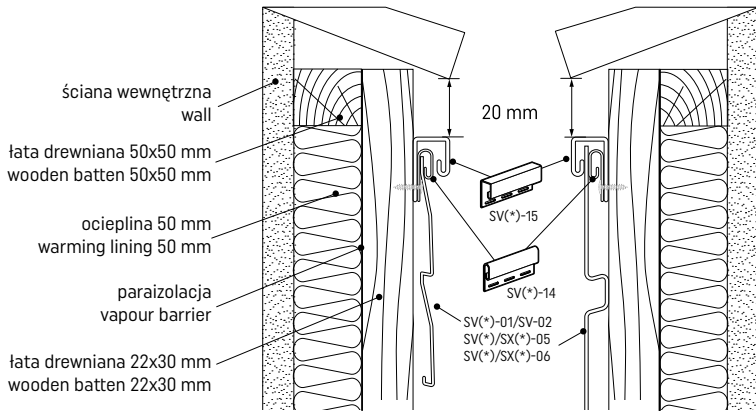

## 4. ETAPY MONTAŻU – OKNA, DRZWI • INSTALLATION STAGES – WINDOWS, DOORS

4.1

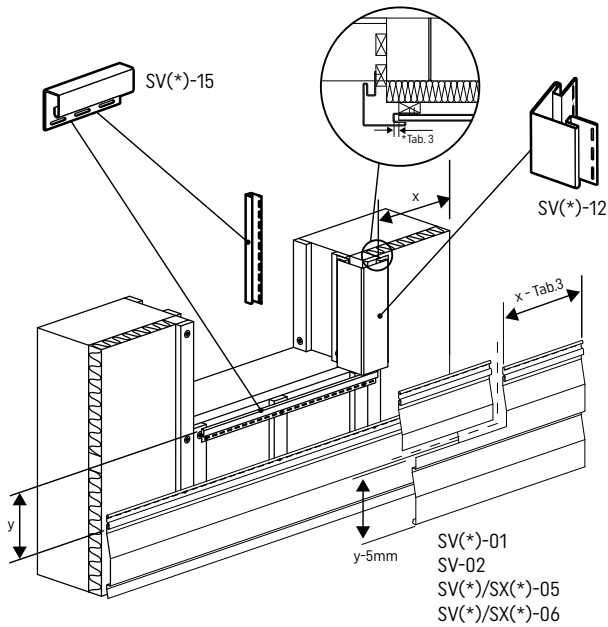

4.2

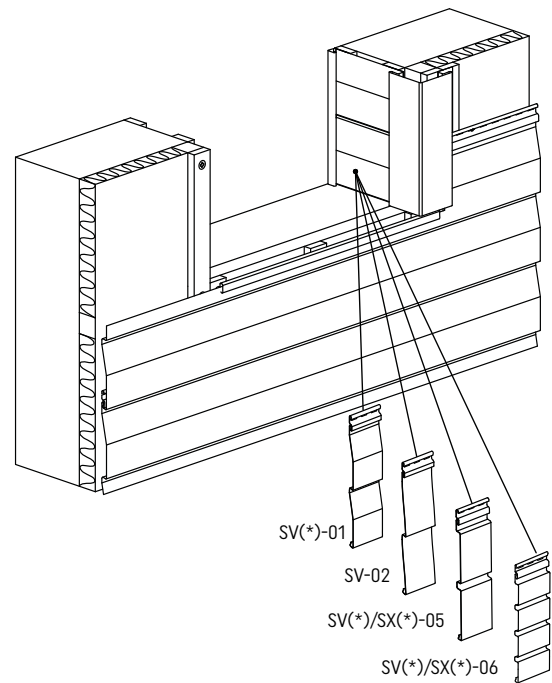

4.3

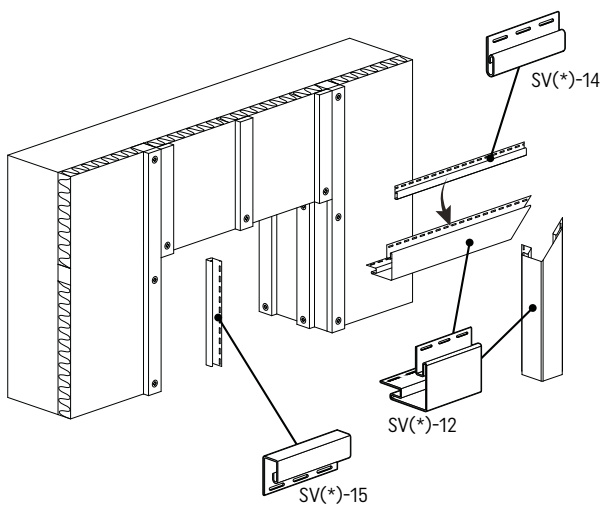

4.4

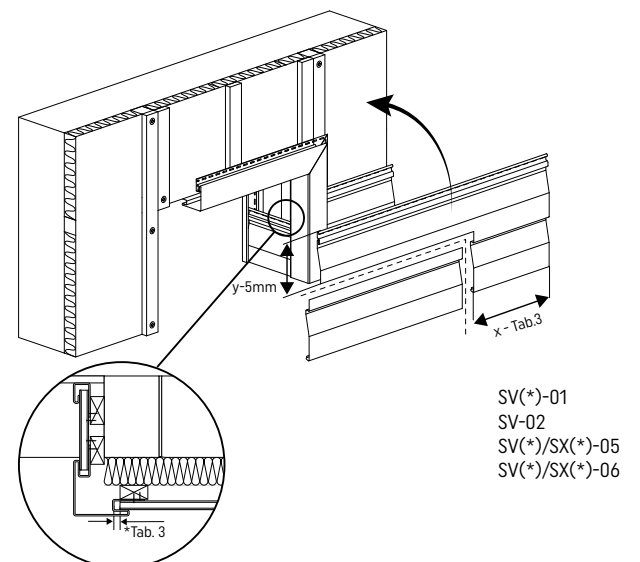

# 5. MONTAŻ PIONOWY • VERTICAL INSTALLATION

5.1

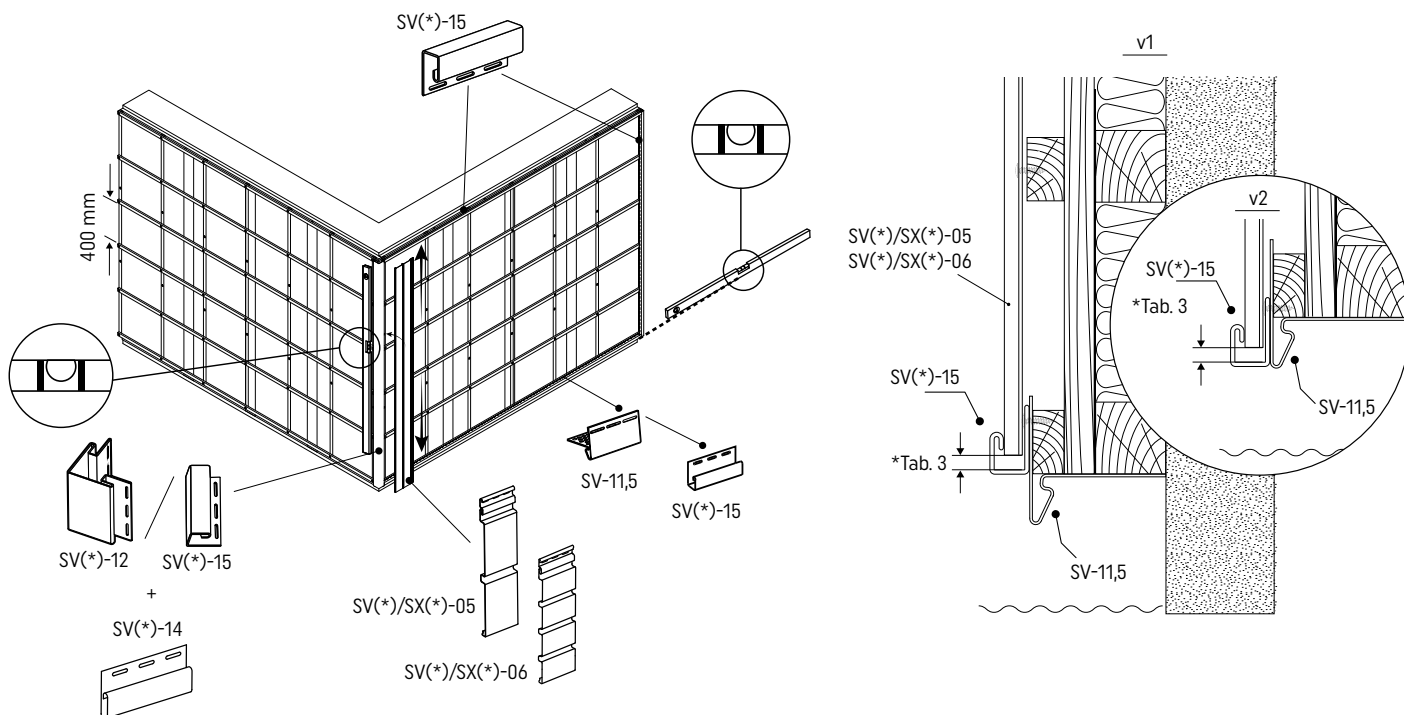

5.2

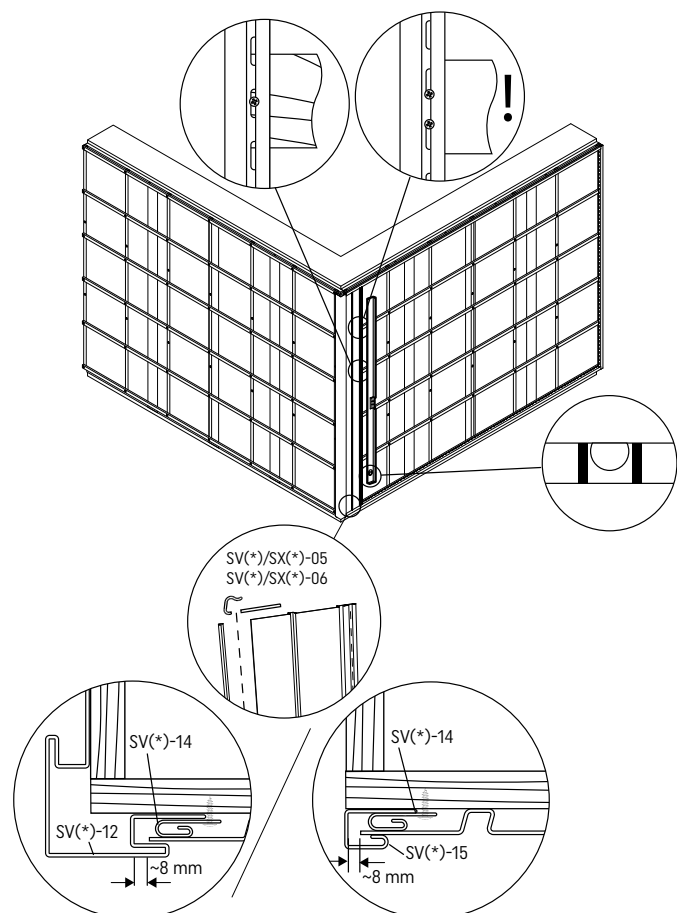

5.3

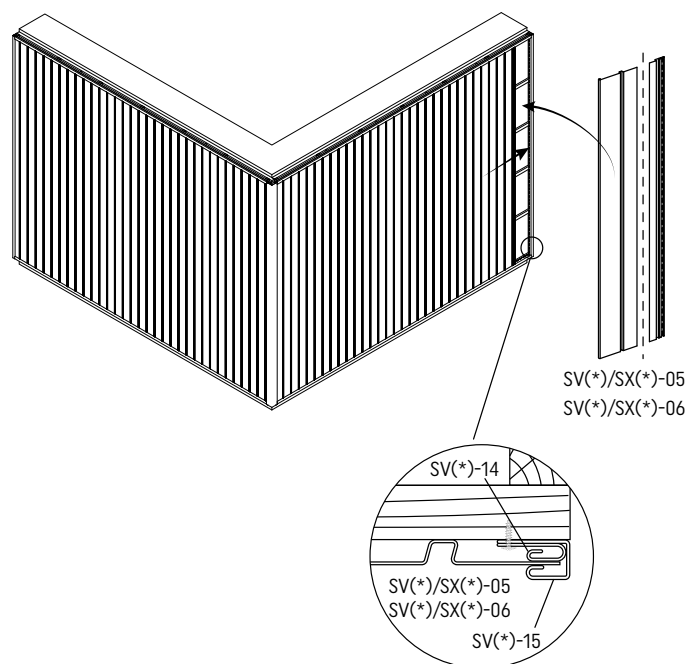

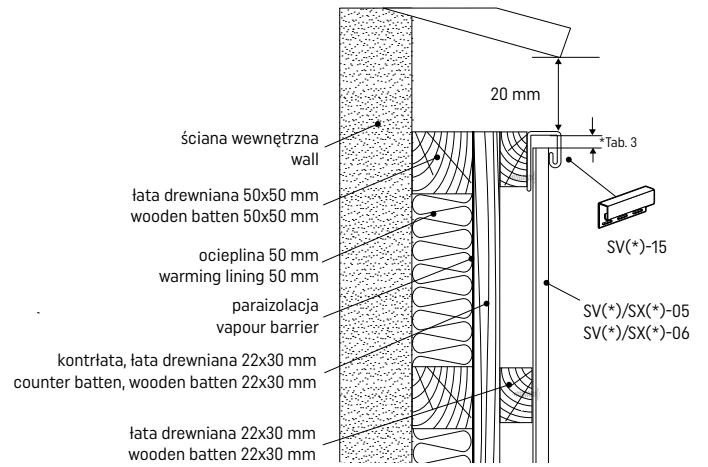
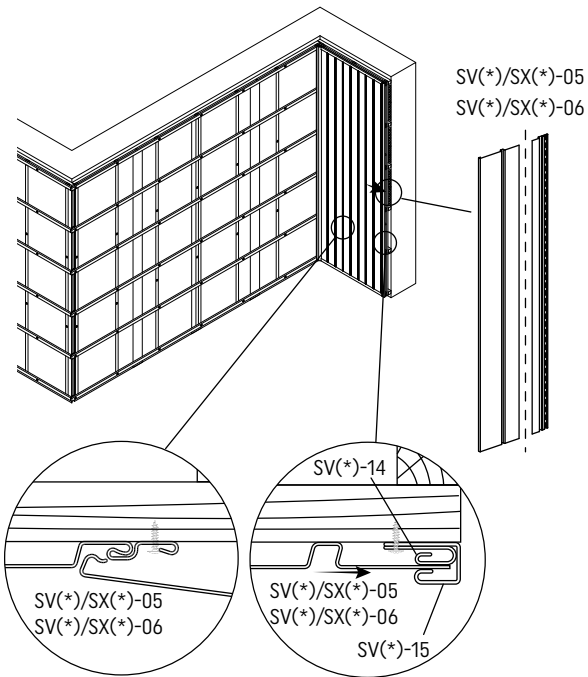
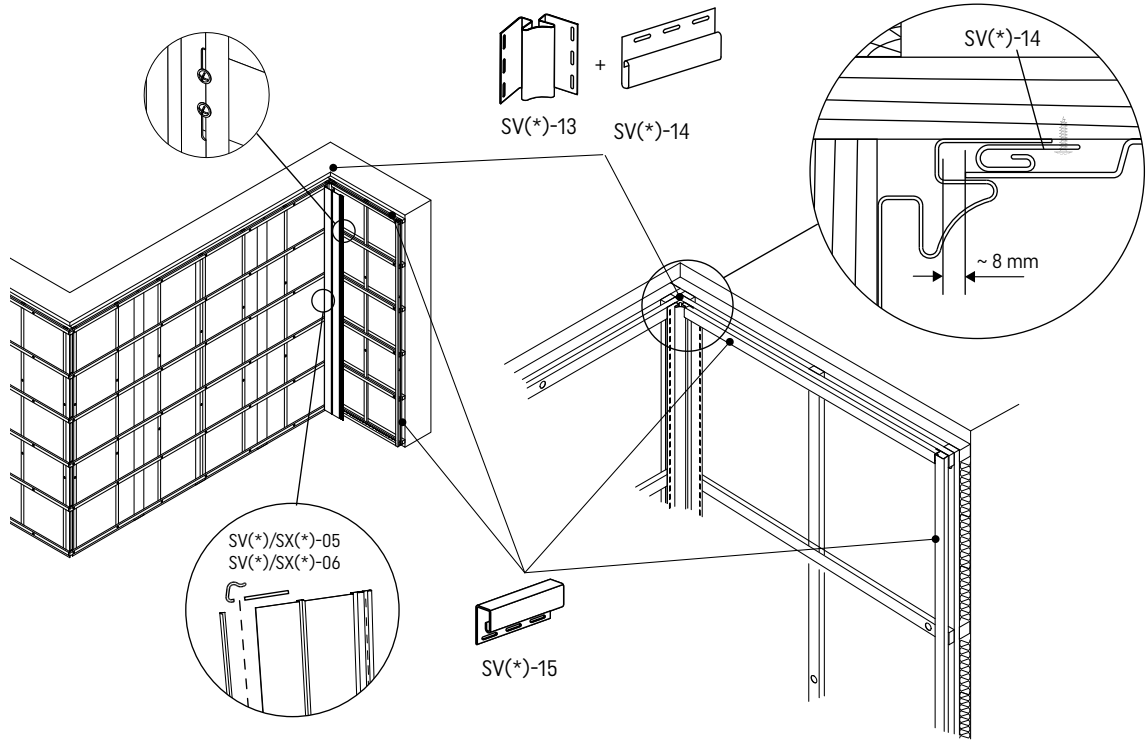

# 6. WYKOŃCZENIE WNĘKI Z SUFITEM • FINISHING THE CEILING RECESS

6.1

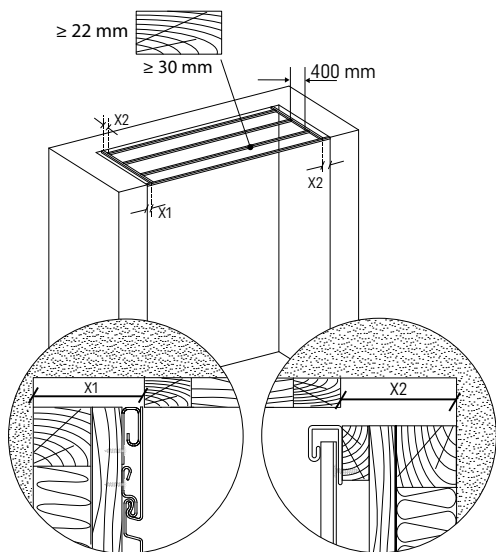

6.2

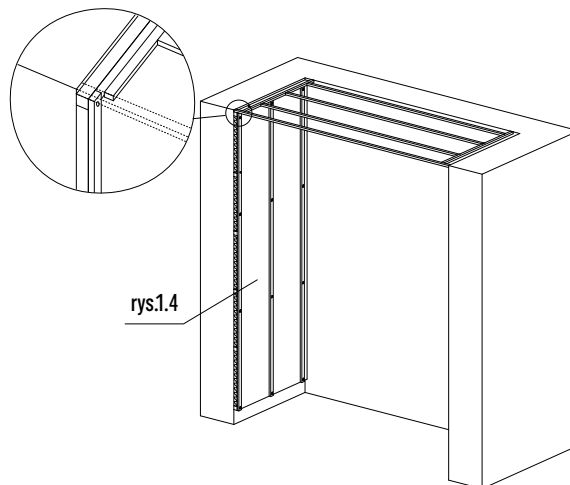

6.3

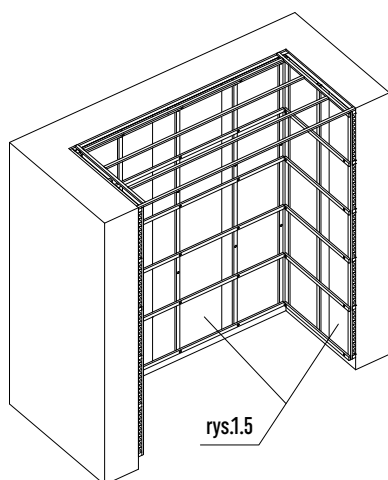

6.4

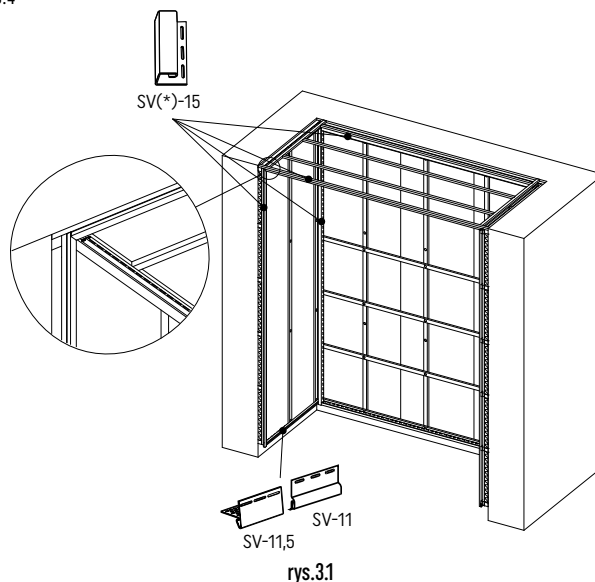

6.5

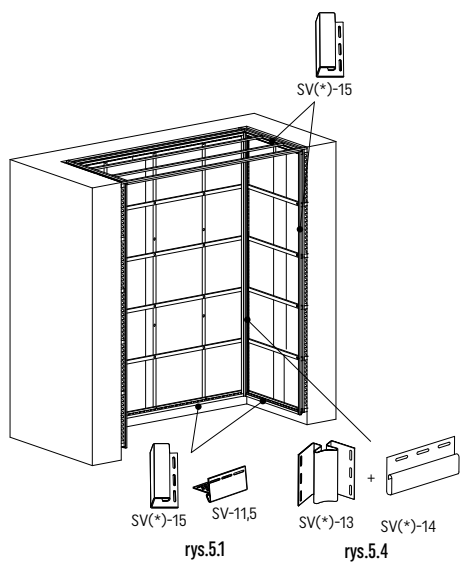

6.6

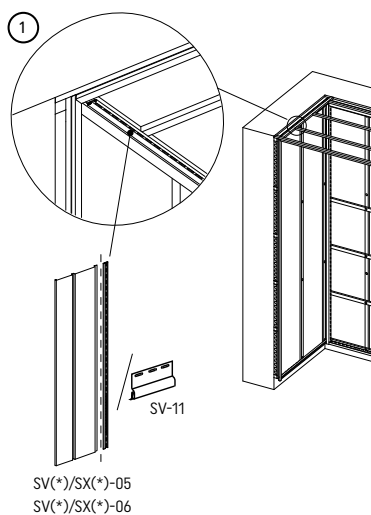

6.7

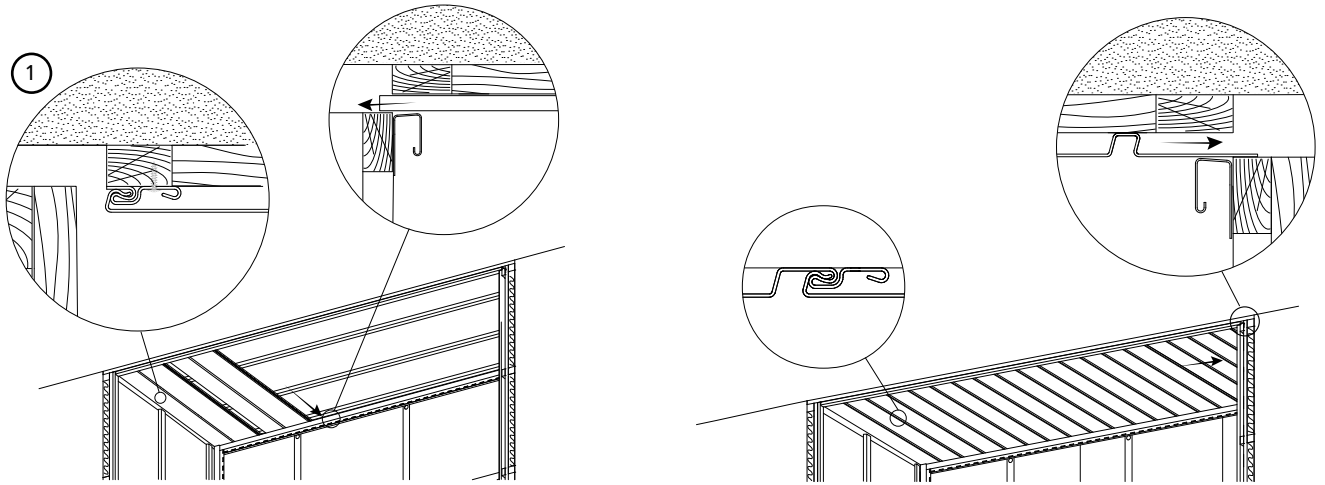

6.8

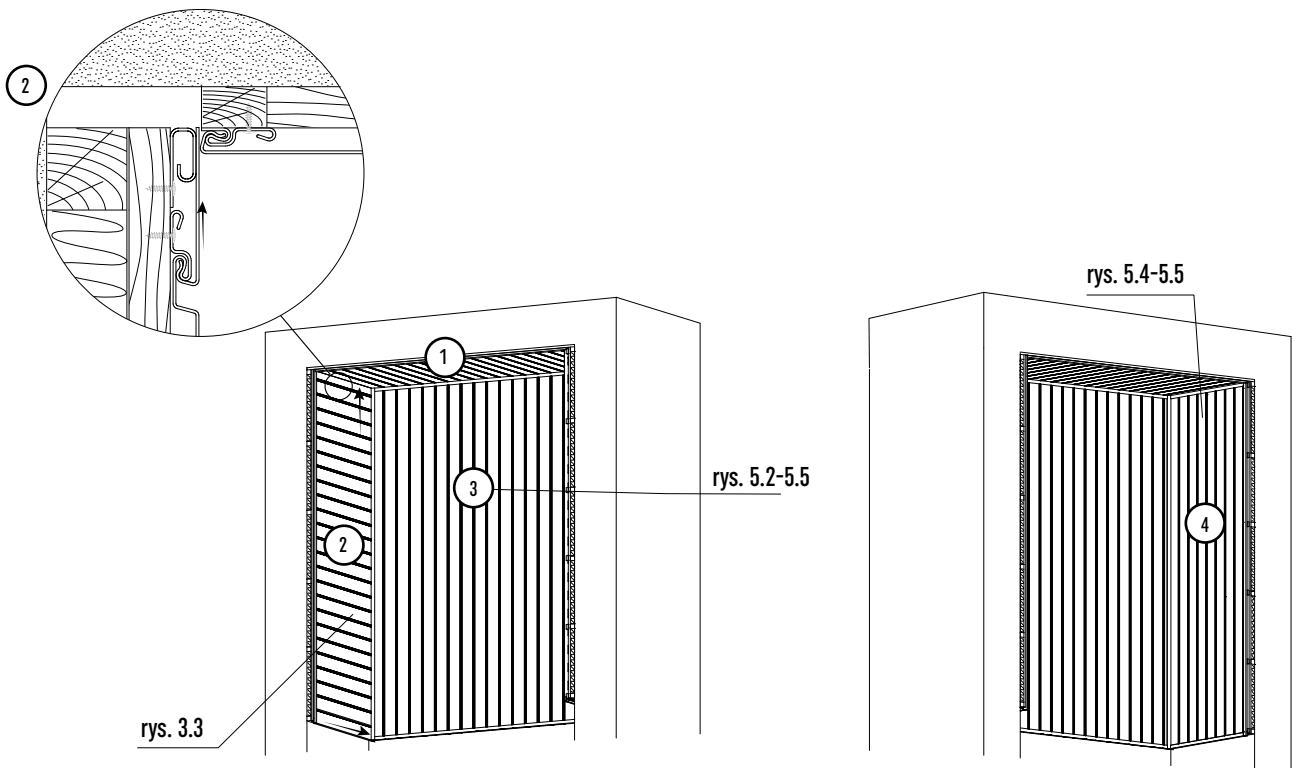

SV(\*)=SV(P/PU)  
SX(\*)=SX(P/PU)

