



marzocchi
BOMBERZ1&DJ

TUNING GUIDE

SAG SETTING

To achieve the best performance from your Marzocchi suspension, adjust the air pressure or coil spring preload to attain your proper sag setting. Sag is the amount your suspension compresses under your weight and riding gear. Sag range should be set to 15–20% **of total fork travel**.

Make sure to set sag with the compression lever in the OPEN mode, see page 5.

Suggested Sag Measurements

Travel	15% sag (Firm)	20% sag (Plush)
100mm (3.9in)	15mm (0.6in)	20mm (0.8in)
130 mm (5.1in)	19.5 mm (0.7in)	26 mm (1.0 in)
140 mm (5.5 in)	21 mm (0.8 in)	28 mm (1.1 in)
150 mm (5.9 in)	22 mm (.9 in)	30 mm (1.2 in)
160 mm (6.3 in)	24 mm (1.0 in)	32 mm (1.3 in)
170 mm (6.7 in)	26 mm (1.0 in)	34 mm (1.3 in)
180 mm (7.1 in)	27 mm (1.1 in)	36 mm (1.4 in)

Your fork has a 4 digit ID code on the back of the lower leg. Use this number at www.Marzocchi.com to find out more information about your fork, including fork travel.

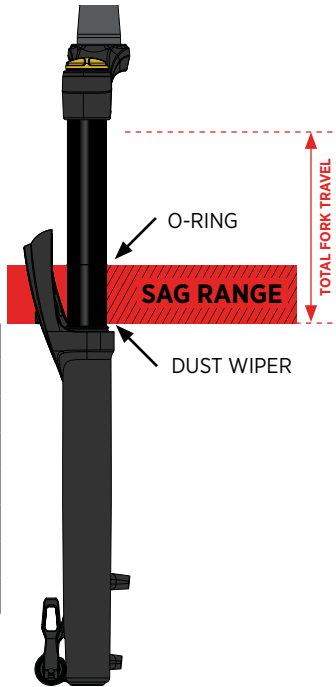



The recommended settings in this tuning guide are designed to be a **starting point**, in order to get you out on your first ride in as few steps as possible. Consult your bike manufacturer's instructions for setup recommendations.

As you ride and get used to your new fork, adjust your settings as needed. Detailed information and videos can be found in the online owner's manual.

Suggested Starting Points for Setting Sag (Air)

Rider Weight (lbs)	Rider Weight (kgs)	BOMBER Z1 and DJ Pressure (psi)
120-130	54-59	55
130-140	59-64	59
140-150	64-68	63
150-160	68-73	67
160-170	73-77	72
170-180	77-82	76
180-190	82-86	80
190-200	86-91	85
200-210	91-95	89
210-220	95-100	93
220-230	100-104	97
230-240	104-109	102
240-250	109-113	106

Coil Spring Information

Rider Weight (lbs)	Rider Weight (kgs)	Spring Color	Spring Rate
120-150	54-68	Purple	Soft
150-180	68-82	Blue	Medium
180-210	82-95	Green	Firm
210-250	95-113	Yellow	X-Firm



Do not exceed maximum air pressure:
BOMBER Z1 and DJ maximum air pressure is **120 psi**.

REBOUND ADJUSTMENT

The rebound adjustment is dependent on the air pressure setting. For example, higher air pressures require slower rebound settings. Use your air pressure to find your rebound setting.

Turn your rebound knob to the closed position, clockwise until it stops. Then turn it counter-clockwise to the number of clicks shown in the table below.

REBOUND

Rebound controls the rate of speed at which the fork extends after compressing.



Rider Weight (lbs)	Rider Weight (kgs)	BOMBER Z1 and DJ
120-130	54-59	13
130-140	59-64	12
140-150	64-68	11
150-160	68-73	10
160-170	73-77	9
170-180	77-82	8
180-190	82-86	7
190-200	86-91	6
200-210	91-95	5
210-220	95-100	4
220-230	100-104	3
230-240	104-109	2
240-250	109-113	1

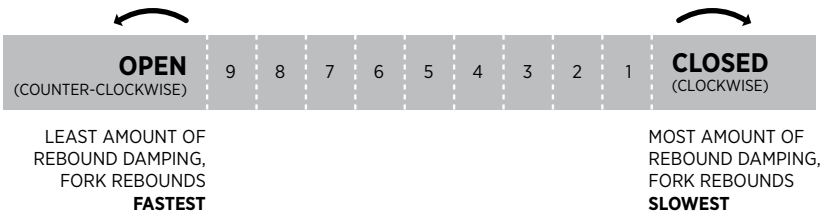

GRIP COMPRESSION ADJUST

The **2-Position Sweep Adjust** lever is useful to make on-the-fly adjustments to control fork performance. Use the positions between OPEN and FIRM modes to fine-tune your compression damping.



Z1 COIL PRELOAD

If your sag measurement is **less** than the desired 15-20% of total travel, turn your preload knob counter-clockwise.

If your sag measurement is **more** than the desired 15-20% of total travel, turn your preload knob clockwise.



INSTALLING THE FRONT WHEEL- 15QR

1. Install the front wheel into the fork dropouts. Slide the axle through the non-drive side dropout and hub.
2. Open the axle lever.



3. Turn the axle clockwise 5-6 complete turns into the axle nut.
4. Close the lever. The lever **must** have enough tension to leave an imprint on your hand.
5. The closed lever position **must** be between 1-20 mm in front of the fork leg.
6. If the lever does not have enough tension, or has too much tension when closed at the recommended position (1-20 mm in front of the fork). See the next page for adjustment instructions.



KABOLT INSTALLATION

1. Install the front wheel into the fork dropouts. Slide the Kabolt axle through the non-drive side dropout and hub.
2. Use a 6 mm hex wrench to torque the Kabolt axle clockwise to the torque specification etched on the head of the Kabolt.



WARNING: Use hand pressure only. Never use any tool to tighten the 15QR levers onto the lower legs. Over-tightening the levers can damage the axle or fork dropouts, leading to a sudden failure with one or more of these components, resulting in **SERIOUS INJURY OR DEATH.**



WARNING: Failure to secure the axle properly can cause the wheel to become detached from the bicycle, resulting in **SERIOUS INJURY OR DEATH.**

ADJUSTING THE LEVER POSITION

1. Note which direction the axle lever needs to turn to achieve proper orientation.
2. Open the axle lever in the fork.
3. While holding the QR lever open and stationary so it cannot rotate, use a 4mm hex wrench in the center of the end of the axle to adjust lever position. With the 4mm adjuster set properly, you should start to feel tension in the axle when the QR lever is 90 degrees before full closure in the vertical position.
4. Repeat the axle installation instructions to verify proper installation and adjustment.



4mm hex adjuster at center of threaded axle end.

INSTALLING THE FRONT WHEEL - 20MM THRU-AXLE DJ Only

1. Install the front wheel into the dropouts and slide the axle through the dropouts and hub.
2. Using a 5mm hex wrench, torque the axle to 2.15 Nm (19 in-lb).
3. Torque the two pinch bolts on the rider's left dropout to 2.15 Nm (19 in-lb).
4. Compress the fork a couple of times to let the right side of the dropout float and settle to its low-friction point.
5. Torque the two pinch bolts on the rider's right dropout to 2.15 Nm (19 in-lb).

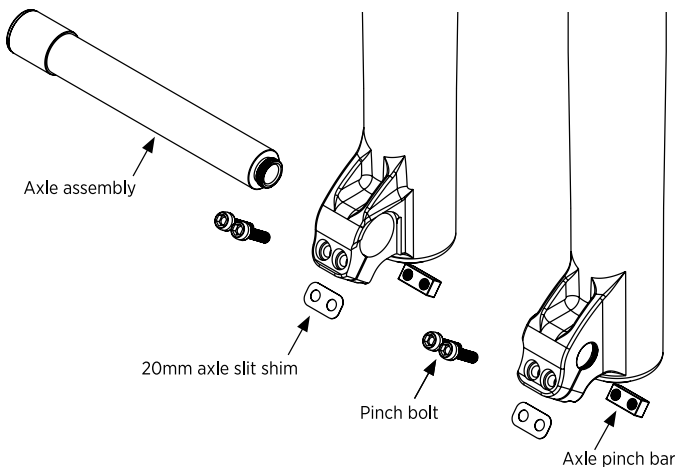

WARNING: Failure to secure the axle properly can cause the wheel to become detached from the bicycle, resulting in **SERIOUS INJURY OR DEATH.**

MOUNTING DISC BRAKES

The BOMBER Z1 and DJ use 180 mm post mounts that allow you to bolt your caliper directly to the fork and utilize a 180 mm rotor.

If your current 180 mm brake setup came with bolts and a caliper spacer, you may need to source shorter bolts as you will not need a caliper spacer when using a 180 mm rotor.

If using a 203 mm rotor, you will need to source the appropriate caliper spacer and bolts. Contact the brake manufacturer for further information.

⚠ WARNING: Follow your brake manufacturer's installation instructions for proper installation and adjustment of the brake system. Failure to properly install and adjust your brakes can lead to a loss of control of the bicycle which can result in SEVERE INJURY OR DEATH.

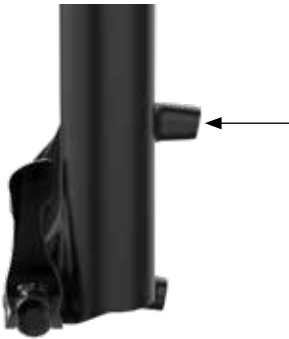

← 2x M6 x 1,0-6H
(full thread 12 mm)

Disc brake caliper mount bolts must have 10-12mm of thread engagement.

Torque bolts to manufacturer's specification.
Bolt torque must not exceed 90 in-lb.

ADDITIONAL TUNING OPTIONS

CLIP-ON VOLUME SPACERS

Changing volume spacers in the BOMBER Z1 and DJ fork is an easy internal adjustment that allows you to change the amount of mid stroke and bottom out resistance.

If you have set your sag correctly and are using full travel (bottoming out) too easily, then you could install one or more spacers to increase bottom out resistance.

If you have set your sag correctly and are not using full travel, then you could remove the spacer to decrease bottom out resistance.

Installation procedure and tuning options are available online at:
www.Marzocchi.com

BOMBER Z1 Volume Spacer Configurations

Travel	Volume Spacers Factory Installed	*Max Volume Spacers
180 mm	1	5
170 mm	1	6
160 mm	2	7
150 mm	3	7
140 mm	4	8
130 mm	5	8

BOMBER DJ Volume Spacer Configurations

Travel	Volume Spacers Factory Installed	*Max Volume Spacers
100 mm	8	10

TYPICAL AIR SPRING CURVES

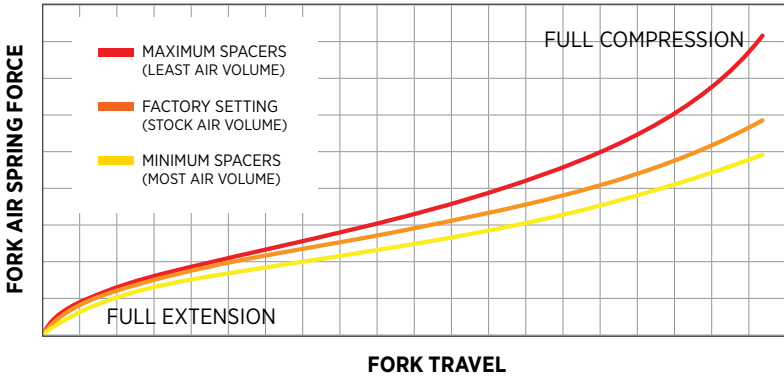

SEE ADDITIONAL INFORMATION AND VIDEOS:

MARZOCCHI.COM



marzocchi

©MARZOCCHI. 2020 // 1.800.369.7469
915 Disc Drive, Scotts Valley, CA 95066 USA
605-00-256 REV B

MARZOCCHI.COM