

SHENZHEN TOPWAY NEW ENERGY CO., LTD.



15KWH Mobile ESS Battery

Product instruction



Catalogue

1. Safety tips	2
1.1 Preface	2
1.2 Safety disclaimer	2
1.3 Description of safety matters	2
2 Product description	3
2.1 Product dimension	3
2.2 Product details	4
2.3 Electrical schematic diagram	6
2.4 Parallel Connection Diagram	7
3 Technical specifications	8
4 BMS characteristics	9
4.1 Instructions for LED lights	9
4.1.2 SOC capacity indicator	9
4.2 Boot and sleep mode	12
4.3 Communication area	12
5 Operating instructions	14
5.1 Operating instructions of the display screen	14
5.1.1 Introduction of LCD Display	14
5.1.2 Boot screen	14
6 Product list and tools	20
6.1 Product packing lists	20
6.2 Prepared tools and instruments	错误！未定义书签。
7 Instruction manual	21

1. Safety tips

1.1 Preface

Thanks for choosing Topway New Energy power wall battery. In order to make you better use and maintain this product, please read the user manual carefully before use.

The features of this product are as follows:

1. Adopt brand new lithium iron phosphate cell; Higher security; In the standard state, 100% DOD charge-discharge ≥ 4000 times cycle;
2. Highly integrated analog front end; Isolating power supply circuit;
3. Integrated serial port IC, high voltage accuracy ($\leq 20\text{mV}$), high current accuracy ($\leq 2\% @ \text{FS}$);
4. Four-channel battery temperature detection ($\leq 2^\circ\text{C}$), SOC estimation function, SOH estimation function;
5. Short-circuit protection function, adjustable overcurrent protection, a variety of sleep and wake up mode, low power consumption;
6. Dual-port RS485 communication, parameter adjustable setting, buzzer alarm function, LED status indicator function, with charge balance power;
7. Wide temperature range: $-20^\circ\text{C} \sim 60^\circ\text{C}$;
8. Parallel connection (up to 15 groups) application expansion is supported, but serial connection is not recommended.

1.2 Safety disclaimer

When installing, using and maintaining this product, users must read this chapter carefully and follow the safety precautions required in this chapter. Any injuries and losses caused by illegal operation are not related to our company.

1.3 Description of safety matters

1. Keep the battery out of the reach of children and babies;
2. Do not put the battery in the oven or other similar equipment;
3. Do not remove the product label;
4. Do not try to open the battery pack;
5. Do not be exposed to the environment above 60°C (300F);
6. Do not short-circuit the positive and negative terminals of the battery with wires or other metal objects. Do not transport or store batteries with metal objects;
7. Do not expose the battery to direct heat or flame. Do not use or store batteries near fire or high temperature;
8. Do not immerse the battery in water, salt water or any other liquid or make it wet;
9. Do not pierce the battery with any sharp object, knock it with a hammer or similar device,

2.2 Product details

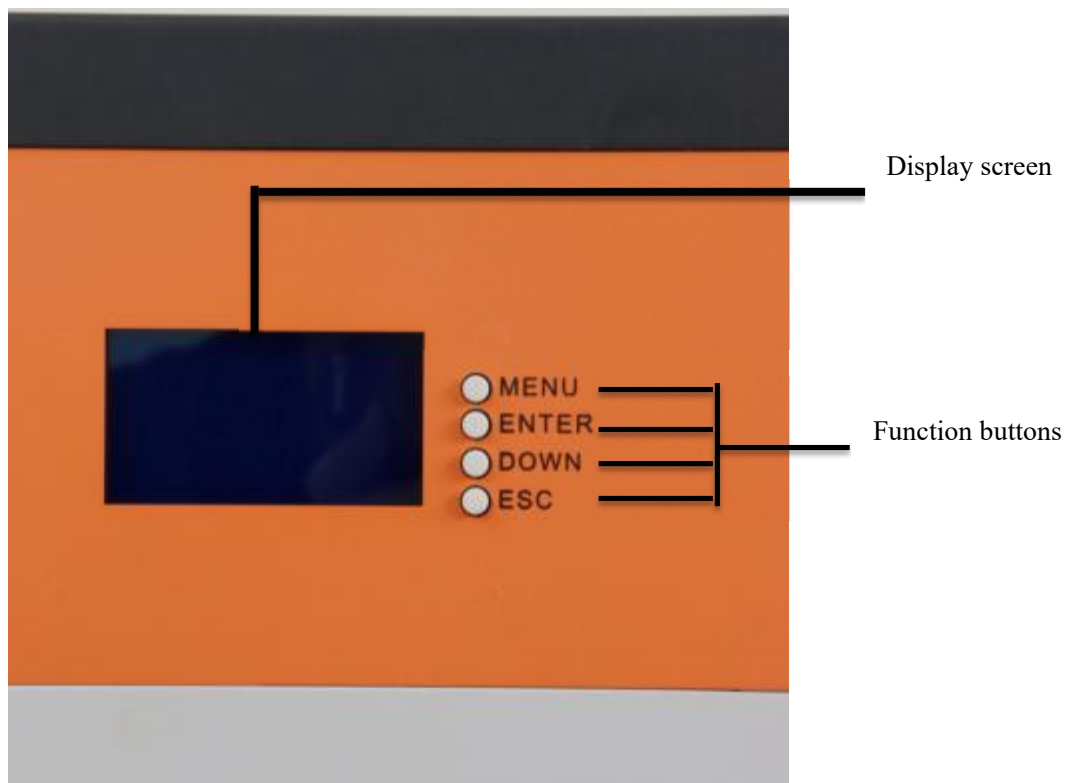

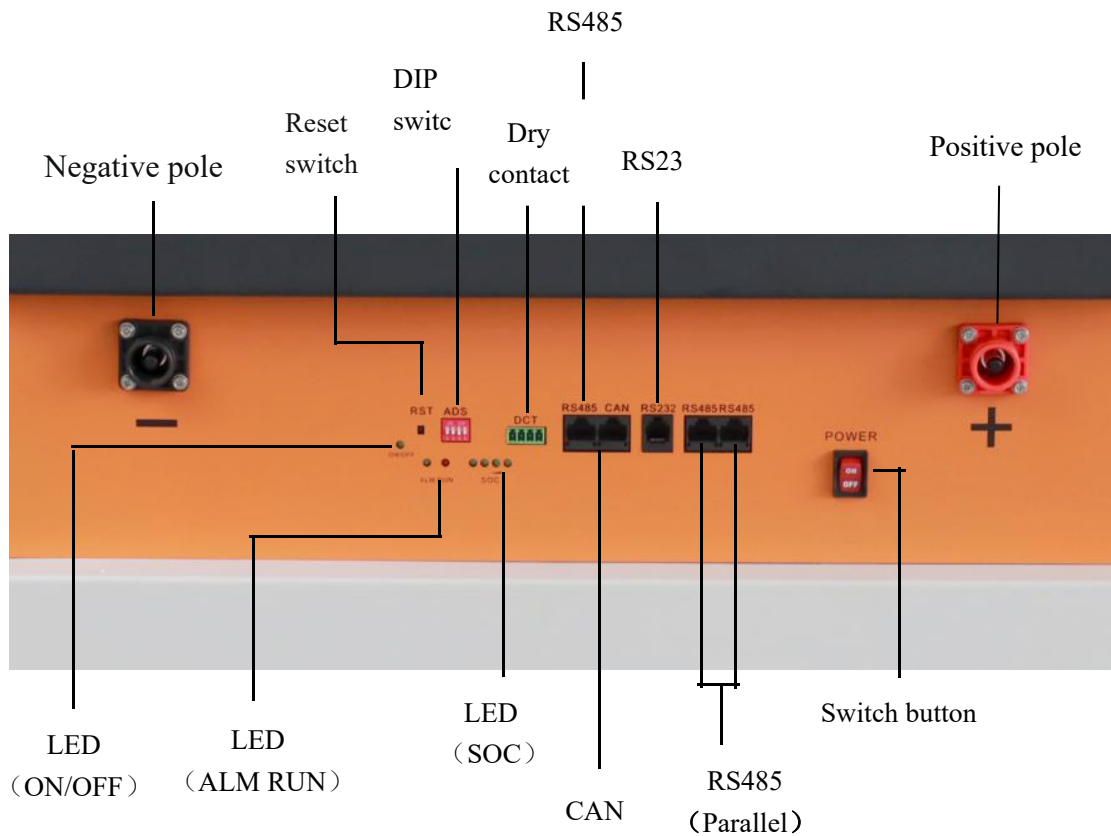
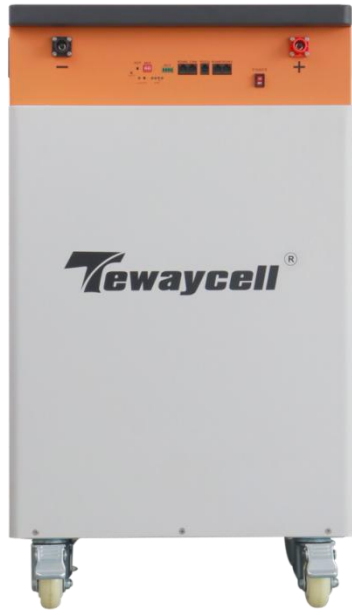

2.3 Electrical schematic diagram

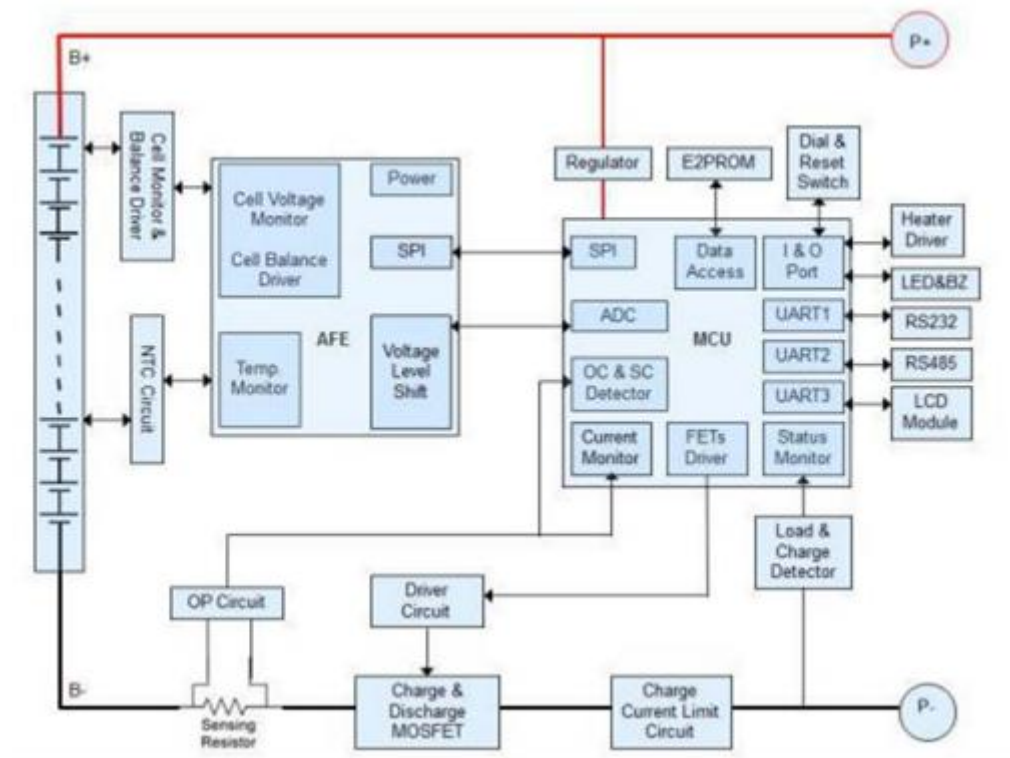

picture1 Electrical schematic diagram

2.4 Parallel Connection Diagram

Support up to 15 batteries in parallel.



Picture 2 Parallel connection diagram

3 Technical specifications

Table 1 Technical specification table

No.	Project	Specifications	
1	Model	TW-MB-51300-100A-HBW	TW-MB-48300-100A-HBW
2	Nominal capacity	300Ah@0.2C	
3	Nominal voltage	51.2V	48.0V
4	Charging voltage	56.8-57.6V	53.2-54V
5	Operating voltage	44.8V~56.8V	42.0V~53.2V
6	Charging current	Charging standard: 0.2C	
		Fast charging: 0.33C	
7	Standard charging mode	At a temperature of 0°C to 45°C, charge to 54.75V with a constant current of 0.2C5A, and then change continuously with a constant voltage of 54.75V until the current is not greater than 0.02C5A.	
8	Maximum charging current	100A	
9	Maximum discharge current	100A	
10	Charging temperature	0°C to 45°C (32°F to 113°F) @60±25% relative humidity	
11	Discharge temperature	-20°C to 60°C (-4°F to 140°F) @60±25% relative humidity	
12	Storage temperature	-0°C to 45°C (32°F to 113°F) @60±25% relative humidity	
13	Measure	900*520*300mm	
14	Line joint	120A Self-Locking Fitting Quick Release Connector	
15	Weight	136Kg	127.5Kg
16	Communication protocol	RS485、RS232、CAN	
17	Support inverter brand	Growatt、Deye、Goodwe、Voltronic power、Sofar、VICTRON、Solis、Megarevo、SRNE	

4 BMS characteristics

4.1 Instructions for LED lights



Picture 3 Battery indicator lamp

Four green capacity indicators, a red alarm indicator, a green running indicator and a switch indicator.

4.1.2 SOC capacity indicator

Table 2 SOC indicator status table

Condition		Charge				Discharge			
Capacity indicator lamp		L1	L2	L3	L4	L1	L2	L3	L4
power (%)	0~25%	Flash 2	OFF	OFF	OFF	ON	OFF	OFF	OFF
	25~50%	ON	Flash 2	OFF	OFF	ON	ON	OFF	OFF
	50~75%	ON	ON	Flash 2	OFF	ON	ON	ON	OFF
	75~100~	ON	ON	ON	Flash 2	ON	ON	ON	ON
Running indicator light		ON				Flash 3			

4.1.3 Status indicator

Table 3 Status indicator status table

Status	Warning/Normal/ Protection	ON/OFF	Run	Alert	LED Battery Level Indicator			Explain	
		•	•	•	•	•	•		
Shut down	Sleep mode	ON	OFF	OFF	OFF	OFF	OFF	OFF	Light off
Standby	Normal	ON	Flash 1	OFF	According to the electricity indication			Standby mode	
	Warning	ON	Flash 1	Flash 3				Module low voltage	
charge	Normal	ON	ON	OFF	According to the power indicator (the maximum LED of the power indicator flashes 2)			The maximum power LED flashes (flash 2),and the ALM does not flash during the overshoot.	
	Warning	ON	ON	Flash 3					
	Overcharge Protection	ON	ON	OFF	ON	ON	ON	ON	If there is no mains supply,the indicator turns to standby
	Temperature,over current,failure, protection	ON	OFF	ON	OFF	OFF	OFF	OFF	OFF
discharge	Normal	ON	Flash 3	OFF	According to the electricity indication				
	Warning	ON	Flash 3	Flash 3					
	UVLO	ON	OFF	OFF	OFF	OFF	OFF	OFF	Stop discharge
	Temperature, over current, short out, reversed polarity ,FAIL-SAFE	ON	OFF	ON	OFF	OFF	OFF	OFF	OFF
Invalid		OFF	OFF	ON	OFF	OFF	OFF	OFF	Stop charging and discharging

Table 4 LED flashing description

Flashing mode	ON	OFF
Flash 1	0.25s	3.75s
Flash 2	0.5s	0.5S
Flash 3	0.5s	1.5s

4.2 Boot and sleep mode

Sleep mode: the battery will be in sleep mode if any of the following conditions are met

- 1) The battery or battery pack over discharge protection lasts for 30 seconds and is not released.
- 2) Press the power on / off button for 3 seconds and release.
- 3) The minimum voltage of the battery is lower than the "sleep voltage" setting in the setting, without charging and discharging.
- 4) Standby for more than 24 hours without charging and discharging.
- 5) Switch to the upper computer for sleep manually.

Wake up: the battery will exit sleep mode if any of the following conditions are met

- 1) Charger is plugged in;The charger voltage is greater than 48V.
- 2) Press the power on / off button for 3 seconds and release.
- 3) Plug in the communication cable and open the upper computer software (not available if it is under over discharge protection).

Note: if over discharge protection is enabled, the battery will be in sleep mode. The battery will wake up automatically every 4 hours and turn on the charge / discharge MOS. If charging is available, the battery will be charged, otherwise it will return to sleep mode. If it has been awakened 10 times but cannot be charged, the battery will not wake up again automatically.

4.3 Communication area



Picture 4 Communication interface diagram

1. RS232: BMS can communicate with upper computer through RS232 interface, so as to monitor various information of battery, including battery voltage, current, temperature, status and battery production information, etc. the default baud rate is 9600bps.
2. RS485: with dual RS485 interface, you can view the information of pack. The default baud rate is 9600bps. If it is necessary to communicate with the monitoring equipment through RS485, the monitoring equipment is used as the host, polling data according to the address, and the address setting range is 1 ~ 15.
3. CAN: CAN communication, baud rate 9600bps.
4. DCT: dry contact interface.

5. ADS: dial switch

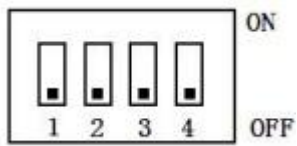

6. Rst: reset button

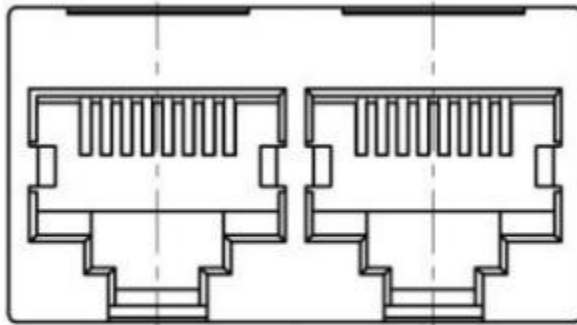

CAN and RS485 interface



1 2 3 4

Dry contact

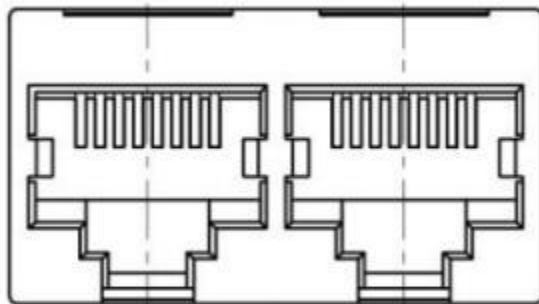

Parallel communication port

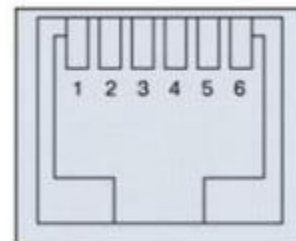

communication interface

5 Operating instructions

5.1 Operating instructions of the display screen

5.1.1 Introduction of LCD Display

Button Description:

MENU: enter the management system.

Enter: enter the submenu.

Down: moves the cursor down or to the next page.

ESC: returns to the previous one

5.1.2 Boot screen



Battery protection status:

Overtoltage: OV

Low voltage: LV

Overtemperature: OT

Low temperature: IT

Over current: OC

Short circuit: SC

Note:when the battery is protected,the corresponding protection status will be displayed; otherwise,the protection status will not be displayed as the protection state.

① Press “MENU” to enter the main menu

Note:“>> ”indicates that there is a submenu. Press”ENTER” to enter the submenu



Analog Info	>>
BMS Status	>>
Para Setting	>>
Sys Setting	>>

② Move the cursor to “Analog info” and press “Enter”



Pack V	
Im	
Temperature	>>
Cell Voltage	>>

Move the cursor to "Temperature" and press "Enter" to check the battery temperature information, then press "DOWN" to turn the page



T1	XX°C
T2	XX°C
T3	XX°C
T4	XX°C
PCB-T	XX°C
ENV-T	XX°C

Move the cursor to "Cell Voltage" and press "Enter" to check the battery voltage information, then press "Down" to turn the page



Cell 01	xxxxmV
Cell 02	xxxxmV
Cell 03	xxxxmV
Cell 04	xxxxmV
Cell 05	xxxxmV
Cell 06	xxxxmV
Cell 07	xxxxmV
Cell 08	xxxxmV
Cell 09	xxxxmV
Cell 10	xxxxmV
Cell 11	xxxxmV
Cell 12	xxxxmV
Cell 13	xxxxmV
Cell 14	xxxxmV
Cell 15	xxxxmV

Move the cursor to "CellCapacity" and press "Enter" to check the battery capacity information



SOC	X%
FCC	XAH
Rm	XAH
CC	0

- ③ Move the cursor to “BMS Status”, press “Enter” to check the battery status, and press “▼” to turn the page



Status	IDLE/DISCHG/ CHARGE/FULL
Record	»
BMS Status	»

Move the cursor to "Record", then press "Enter" to check the battery alarm information, then press "DOWN" to turn the page.

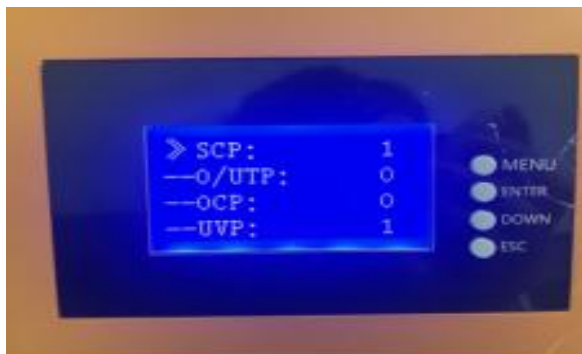

SCP	
O/UTP	
OCP	
UVP	
OVP	

Move the cursor to "BMS Status", then press "Enter" to check the battery protection information, and then press "DOWN" to turn the page.



UV	Y/N
UVP	Y/N
OC	Y/N
OCP	Y/N
OT	Y/N
OTP	Y/N
OV	Y/N
OVP	Y/N
SCP	Y/N
Failure	Y/N

- ④ Move the cursor to "Para Setting" and press "Enter" to check the gyroscope information, then press "▼" to turn the page.



- ⑤ Move the cursor to "Sys Setting", then press "Enter" to check the version information, and then press "▼" to turn the page.





- ⑥ Hibernation and activation functions

After 1 minute of button-free operation in normal operation, the display will turn off (backlight only), and pressing any button while the screen is off will allow the screen to light up and function normally.

6 Product list and tools

6.1 Product packing lists

Home energy storage system series power supply has been strictly inspected before delivery, but may be damaged in transit, therefore, after unpacking the box, please check whether the following items are complete, confirm the model, capacity, input voltage and output voltage, and whether the specified content when ordering; If anything abnormal or inconsistent occurs, please contact the distributor as soon as possible.

	Picture	Description	Qty
Power wall battery			1 pieces
Product manual			1 pieces
Positive/negative connector plug (with 6AWG*1000mm wire and SC-25 copper terminal)			Positive/ negative each one
Signal line		Communication cable	2 pieces

7 Instruction manual

1. Place the battery in an appropriate position, plug the positive/negative connector into the positive/negative socket, and then plug in the network cable.

