



User Manual

# Prep Center S™

Model: 80-120

REV. 1/17/22

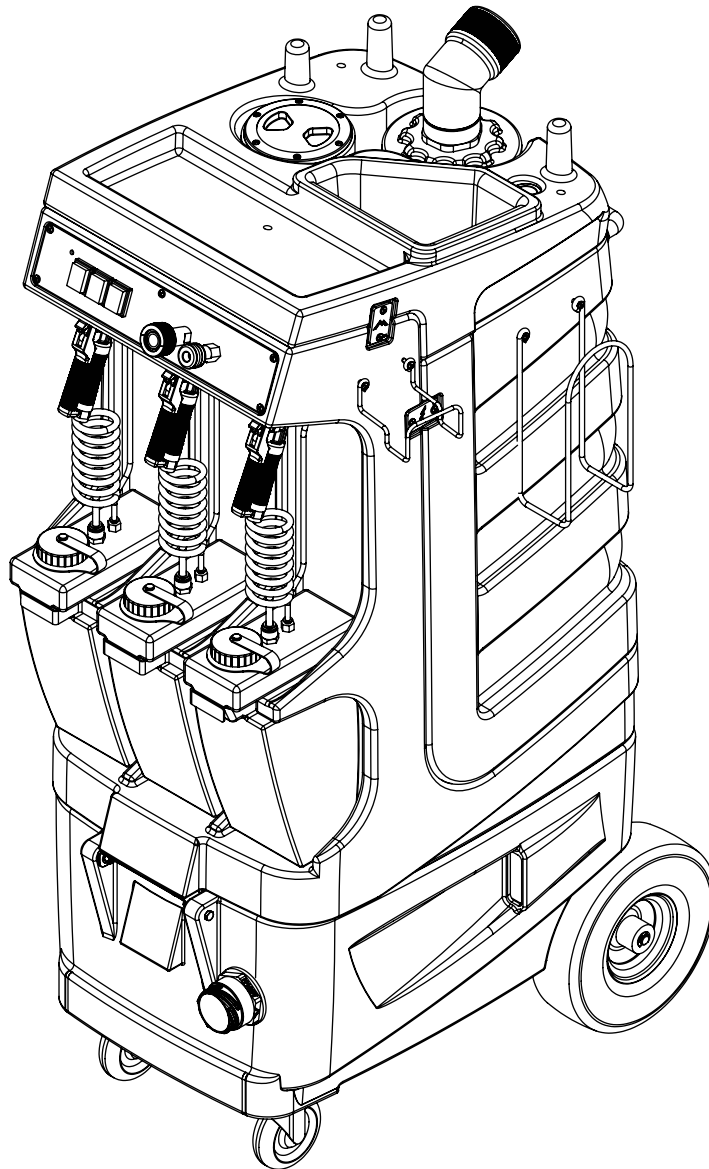

13655 Stowe Dr. Poway, CA 92064

P: (858) 679-1191

F: (858) 726-6005

[www.mytee.com](http://www.mytee.com)

***Dear Customer:***

Congratulations on the purchase of your new Prep Center S. As technology continues to develop you can work confidently knowing that both Mytee and its employees are equally dedicated to developing with the industry and its advances.

Like any other piece of machinery or technology, the Prep Center S also requires proper maintenance and care to keep the product working over extended use. Neglecting your machine, abusing it or not operating it properly can void its warranty and prevent the machine from performing to the quality and standard you'd expect out of the Mytee line.

If you have any warranty concerns or questions, please review this manual thoroughly or do not hesitate to contact your distributor. If there are questions regarding maintenance, replacement, or ordering parts please contact an authorized Mytee Service Center. Visit [www.mytee.com/support/find-distributors](http://www.mytee.com/support/find-distributors) to find your nearest Service Center.

Before using your Mytee product, please read this manual thoroughly.

*Sincerely,*

*Mytee Customer Care Dept.*

	<b>Important Safety Information</b> .....	4
<b>1</b>	<b>At a Glance</b> .....	6
	1.1 - Technical Specifications .....	6
	1.2 - Included with the Prep Center S .....	6
	1.3 - Prep Center S Features .....	7
	1.4 - Prep Center S Switch Plate .....	8
<b>2</b>	<b>Machine Operation</b> .....	9
	2.1 - Powering the Prep Center S .....	9
	2.2 - Connecting Vacuum and Solution Hoses .....	9
	2.3 - Connecting Shop Air Line .....	9
	2.4 - Filling the Solution Tank .....	9
	2.5 - Dry Vacuuming .....	9
	2.6 - Hot Water Extraction with the Prep Center S .....	9
	2.7 - Using the Blower Attachment .....	10
	2.8 - Using Auxiliary Chemical Bottles .....	10
	2.9 - Emptying the Recovery Tank .....	10
	2.10 - Storage .....	10
<b>3</b>	<b>Machine Maintenance</b> .....	11
<b>4</b>	<b>Available Accessories</b> .....	12
<b>5</b>	<b>Troubleshooting</b> .....	13

# Important Safety Information

## Grounding Instructions

This machine must be grounded. If it should malfunction or breakdown, grounding provides a path of least resistance for electrical shock. This machine is equipped with a cord having an equipment-grounding conductor and grounding plug. The plug must be plugged into an appropriate outlet that is properly installed in accordance with all local code and ordinances. Do not remove ground pin; if missing, replace plug before use.



Improper installation of the equipment-grounding conductor can result in a risk of electric shock. Be sure to check with a qualified electrician or service person if you are in doubt as to whether the outlet is properly grounded. If the plug will not fit in the outlet do not modify either the plug nor the machine's cord, instead have a proper outlet installed by a qualified technician.

This machine is for use on a nominal 120-volt circuit and with a grounding plug similar to the one in Figure 1 below. If a proper outlet is not available, follow the illustrations of Figure 2 & 3 to install a temporary-grounding plug. This temporary work-around should be used only until a proper outlet (Figure 1) can be installed by a qualified electrician. When and if this type of adapter is employed, screw the adapter's extended tab into place with a metal screw. However, grounding adapters are not approved for use in Canada.

Again, be sure to check the grounding pin for damages and replace if necessary.

The Green, or Green-Yellow, wire in the cord is the grounding wire. When replacing a plug, this wire must be attached to only the grounding pin.

DO NOT use extension cords.

**Please Note for America use only.**

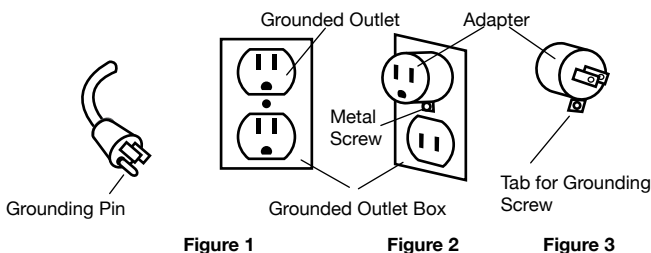

## Parts and Service

Please contact a Mytee service personnel or Mytee authorized Service Center using Mytee original replacement parts and accessories for repairs are needing to be performed. When and if calling Mytee for support, please have your Model and Serial Number available for faster assistance.

## Name Plate

The Model and Serial Number are located on the lower half of the back of the machine near the power plugs and will be required for ordering replacement parts. You can use the space provided on the front of this manual to note down both for future referencing.

## Unpacking the Machine

When your new machine is delivered, please carefully inspect both the shipping carton and the machine for damages. If damage is evident, save both the shipping carton and machine so that the delivering carrier can inspect it. Contact the carrier immediately to file a freight claim if there has been any damage.

## Caution and Warnings

### Symbols

Mytee uses the symbols below to signal potentially dangerous conditions. Always read this information carefully and take the necessary steps to protect personnel and property.



Is used to warn of immediate hazards that will cause severe personal injury or death.



Is used to call attention to a situation that could cause severe personal injury.



Is used to call attention to a situation that could cause minor personal injury or damage to the machine or other property. When using an electrical appliance, basic precautions should always be followed, including the following: Read all instructions before using this machine. This product is intended for commercial use only.

## To reduce the risk of fire, electrical shock, or injury:

1. Read all instructions before using equipment.
2. Use only as described in this manual. Use only manufacturer's recommended attachments.
3. Always unplug power cord from electrical outlet before attempting any adjustments or repairs.
4. Do not unplug by pulling on cord. To unplug, grasp the plug, not the cord.
5. Do not pull or carry by cord. Do not close a door on cord or pull cord around sharp edges or corners.
6. Do not run appliance over cord. Keep cord away from heated surfaces.
7. Do not use with damaged cord or plug. If cord is damaged, repair immediately.
8. Do not use outdoors or on wet surfaces and or standing water.
9. Always unplug or disconnect the appliance from power supply when not in use.
10. Do not allow to be used as a toy. Close attention is necessary when used by or near children.
11. Do not use in areas where flammable or combustible material may be present.
12. Do not leave the unit exposed to harsh weather elements. Temperatures below freezing may damage components and void warranty.
13. Use only the appropriate handles to move and lift unit. Do not use any other parts of this machine for this purpose.
14. Keep hair, loose clothing, fingers, and all parts of the body away from all openings and moving parts.
15. Use extra care when using on stairs.
16. To reduce the risk of fire or electric shock, do not use this machine with a solid-state speed control device.
17. The voltage and frequency indicated on the name plate must correspond to the wall receptacle supply voltage.
18. When cleaning and servicing the machine, local or national regulations may apply to the safe disposal of liquids which may contain: chemicals, grease, oil, acid, alkalines, or other dangerous liquids.
19. Do not leave operating unattended.

# 1 - At a Glance

## 1.1 - Technical Specifications

<b>Body</b>	Roto-molded polyethylene
<b>Tanks</b>	12 gallon (approx.)
<b>Vacuum</b>	Single 3-stage low amp, 100 CFM, 130" water lift
<b>Pump</b>	Diaphragm pump, 120 PSI, 1.3 GPM
<b>Heater</b>	1200 watt heating system – 210° maximum
<b>Rear Wheels</b>	10" foam-filled
<b>Locking Casters</b>	4"
<b>Power Cord</b>	Single 25' 12/3
<b>Amp Draw</b>	20 amps @ 115V 60Hz
<b>Net Weight</b>	144 lbs. (65.3 kg)
<b>Product Dimensions</b>	31" x 19" x 53.5"

## 1.2 - Included with the Prep Center S



**8100 Vac/Sol Hose Assembly**



**8400P Air Lite™ Upholstery Tool**



**H294 Vacuum Hose**



**2x H375 Hose Hangers w/ Hardware**



**PC86 Crevice Tool**



**PC87 Claw Tool**



**A919 Exterior Drying Tool**



**P590 Cuties™ OD Safety Covers**

## 1.3 - Prep Center S Features

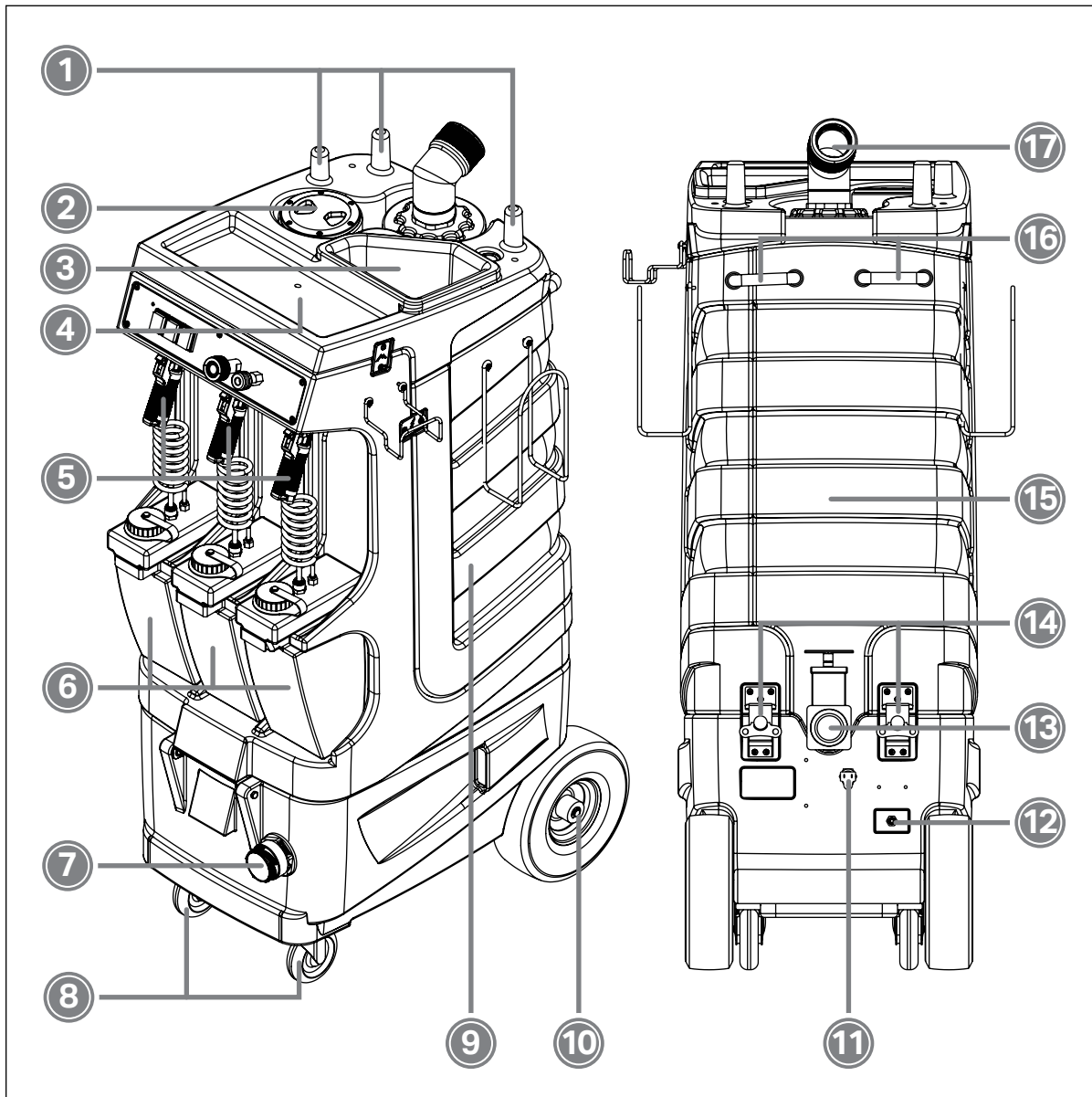

- 1. Pegs for tool storage
- 2. Clear recovery tank lid
- 3. Solution tank opening
- 4. Storage tray
- 5. Three spray nozzles with coiled hoses
- 6. Three on-board chemical storage bottles
- 7. Blower port
- 8. 4" locking casters
- 9. Solution tank

- 10. 10" foam-filled rear wheels
- 11. 25' 12/3 power cord
- 12. Air line input fitting
- 13. Recovery tank drain
- 14. Maintenance access latches
- 15. Recovery tank
- 16. Push handles
- 17. Vacuum hose port

# 1 - At a Glance

## 1.4 - Prep Center S Switch Plate

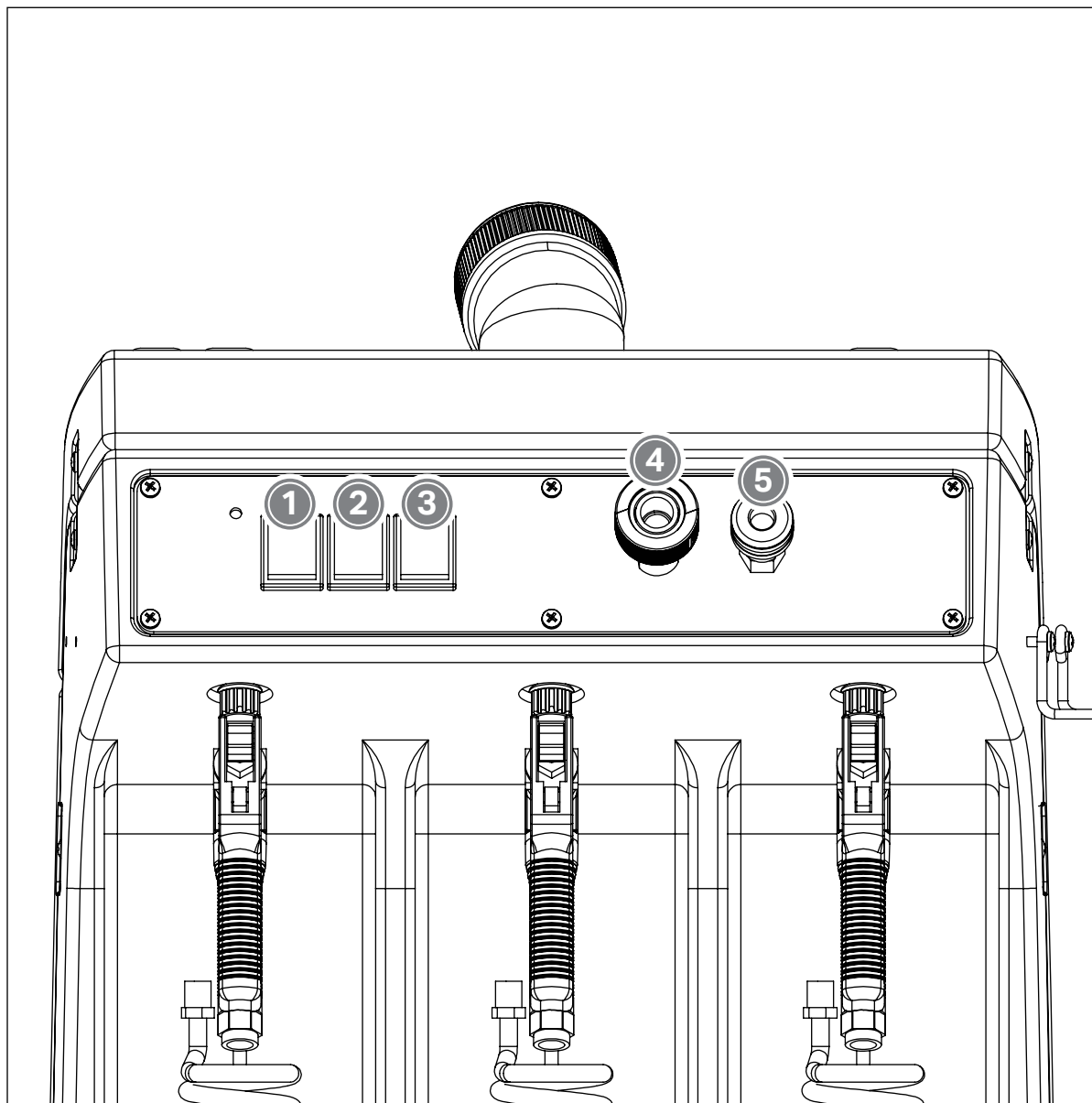

- 1. Vacuum switch
- 2. Pump switch
- 3. Heater switch

- 4. Solution connection fitting
- 5. Air line output fitting



## 2 - Machine Operation

### 2.1 - Powering the Prep Center S

To power the Prep Center S, plug the power cord into a grounded 20 amp outlet. ♦

### 2.2 - Connecting Vacuum and Solution Hoses

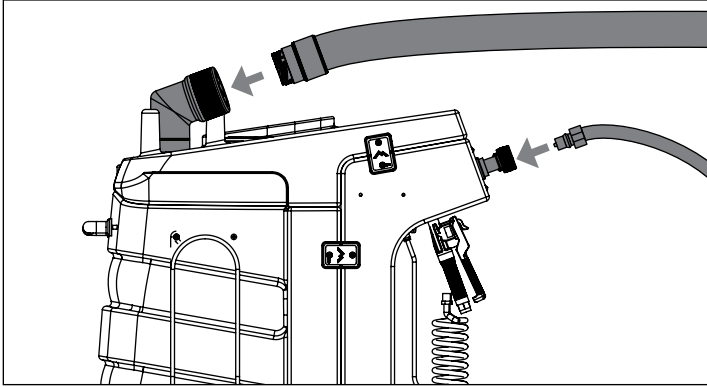

Do not operate machine with a spray nozzle orifice smaller than #2. This can damage the pump switch. ♦



Do not pull on hoses in order to move the unit. Use only the appropriate handles. ♦

Connect the vacuum hose via Cuff-Lynx™ connector to clear elbow on top of the machine. Simply twist the male Cuff-Lynx™ into the elbow. Connect the solution line to female solution quick connect fitting on the switch plate. ♦

### 2.3 - Connecting Shop Air Line

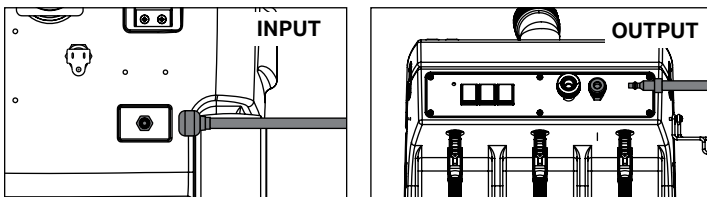

Shop air input is located in the bottom-right corner of the rear of the machine. ♦

Output is located on the switch plate. ♦



Do not use an air source higher than 30 PSI. This can cause damage to hoses. ♦

### 2.4 - Filling the Solution Tank

#### Faucet Fill

The solution tank can be filled from a standard faucet or hose bib. Simply lift the Faucet Fill hose out of the tank and press it against the faucet. Turn on the faucet to allow water to flow into the tank. ♦

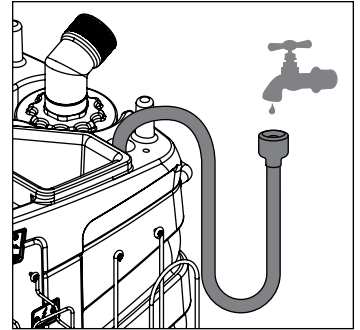

#### Bucket Fill

Fill up a bucket with water and pour into the solution tank through the opening on top of the machine. Add desired chemical according to manufacturer specifications. ♦

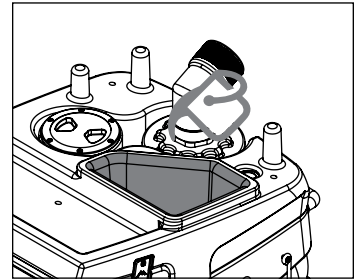

### 2.5 - Dry Vacuuming

**IMPORTANT: DO NOT dry vacuum without a Piglet™ Filter in place on the strainer basket. This will cause damage to the vacuum motor.**

1. Attach a vacuum hose to the clear elbow. ♦

2. Switch on the vacuum and begin vacuuming. ♦

3. Replace the Piglet™ filter regularly. ♦

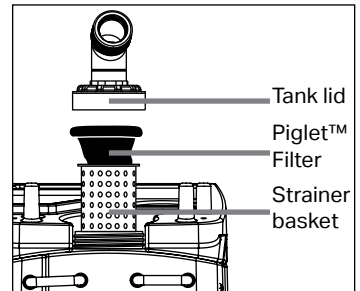

### 2.6 - Hot Water Extraction with the Prep Center S

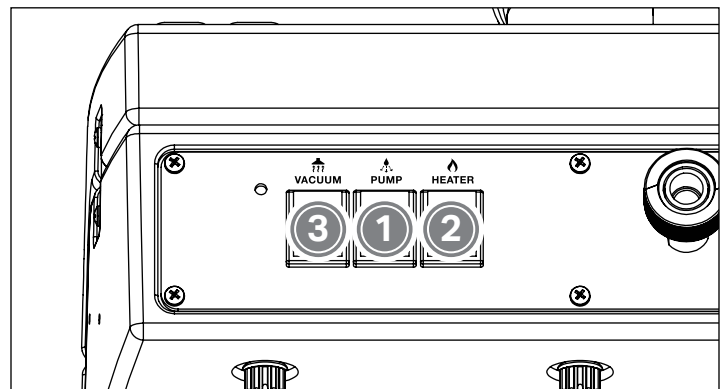

To avoid a vapor lock, follow this procedure when turning on the machine for hot water extraction. ♦

## 2 - Machine Operation

1. Turn **PUMP** switch on. Pull the lever on the cleaning tool to release air in the line. Hold lever until a steady flow of water comes out of the tool.
2. Turn on **HEATER** switch and wait a few minutes for water to heat up.
3. Once water is heated, turn on **VACUUM** and begin cleaning. ♦



Use only low foam or non foaming detergent or shampoo. Damage due to excessive foam will void warranty.



Empty the vacuum tank any time you refill the solution tank in order to prevent vacuum tank overflowing.

### 2.7 - Using the Blower Attachment

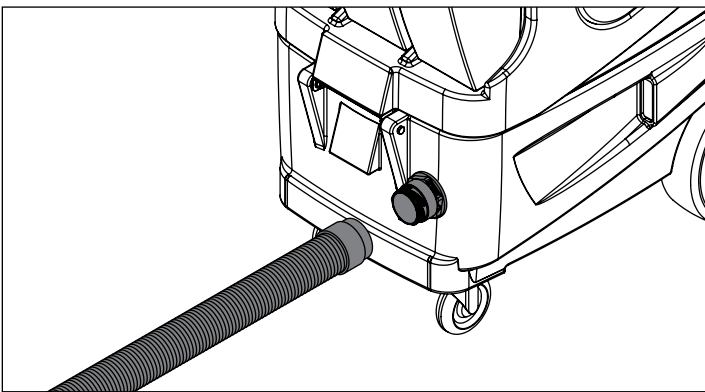

Attach vacuum hose via Cuff-Lynx™ adapter to the blower port on the front of the machine in the bottom-right corner. Switch on the **VACUUM**. The blower attachment uses the exhaust from the vacuum for drying. ♦

### 2.8 - Using Auxiliary Chemical Bottles

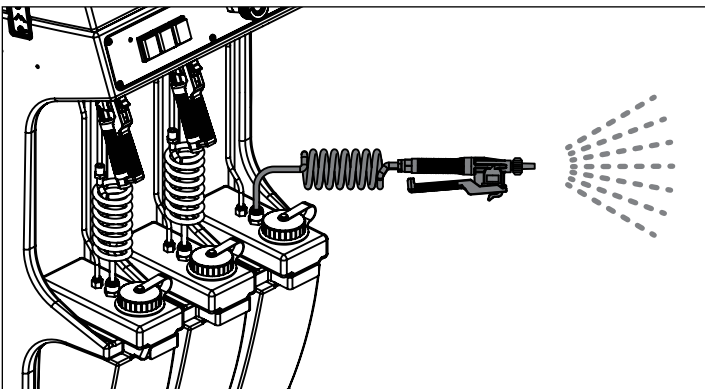

Put desired chemical in the bottle(s) to be used. Connect shop air to the air line input quick connect in the bottom right corner of the rear of the machine. Once the bottle(s) are pressurized, chemical can be sprayed using the attached nozzles. ♦

### 2.9 - Emptying the Recovery Tank

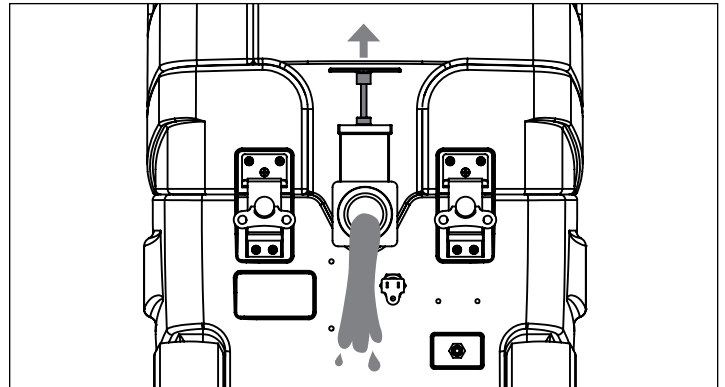

Pull up on the drain valve handle on the rear of the machine to drain the recovery tank into a bucket or drain. ♦

### 2.10 - Storage

When storing the Prep Center S, make sure all liquid is purged from the system and the tanks are drained. This is especially important in cold climates. ♦

# 3 - Machine Maintenance

In order to keep the Prep Center S running smoothly and reduce the risk of damage to the machine and subsequent downtime, Mytee recommends following the maintenance schedule below:

Maintenance Item	Daily	Weekly
Clean and inspect tanks.	X	
Clean and inspect hoses.	X	
Check and clean internal filters.	X	
Check power supply cable.	X	
Clean machine with all-purpose cleaner and cloth.	X	
Check spray nozzles.	X	
Flush solution system with Mytee System Maintainer.		X
Inspect vacuum hoses for holes and loose cuffs.		X
Inspect spray pattern for clogging. If clogged, remove spray tips and soak them in a recommended liquid neutralizer for up to six hours. To remove spray tip, twist spray tip body counter-clockwise.		X
Lubricate casters with water resistant oil.		X
Inspect machine for water leaks and loose hardware.		X

How to use System Maintainer:

1. Thoroughly mix System Maintainer with warm water at a 1:1 ratio in a separate container. Pour into your Extractor's solution tank.
2. Connect a cleaning tool (upholstery tool, wand, etc.) and remove the jet(s) in order to prevent clogging from dislodged mineral build-up.
3. Turn on the Extractor's pump and run the System Maintainer solution through the system and into a bucket or receptacle until you have a solid stream.
4. Let sit for about 5 minutes while the System Maintainer solution does its job inside your Extractor.
5. Finish running the rest of the solution through the system.
6. Run clean water through the system to flush out any remaining System Maintainer. ♦

## 3.1 - Opening the Unit for Maintenance

To open the Prep Center S, loosen the rear latches by turning them one quarter turn counter-clockwise. Flip the latches down and then lift up on the push handle and the machine will open up. ♦

## 3.2 - Filter Maintenance

The Prep Center S has a small filter at the top of the vacuum stack in the recovery tank. This filter should be checked after each use. ♦

## 3.3 - System Maintainer

Regular flushing of the solution system with Mytee System Maintainer keeps your extractor running efficiently by removing hard water scaling that builds up in the system.



Do not tamper with the set screw on the pump pressure switch. This can damage the pressure switch.

## 4 - Available Accessories



**PC88 Interior Drying Tool**



**G008 Piglet™ Filters - pack of 20**



**8400 4" Stainless Steel Upholstery Tool**



**8700 Stainless Steel Crevice Tool**

## 5 - Troubleshooting

Issue	Possible Cause	Solution
Machine is not turning on.	Power cord unplugged.	Plug the power cord into a grounded 20 amp outlet.
	Circuit breaker tripped in building.	Reset breaker in building.
	Faulty switch or power cord.	Contact a Mytee Service Center.
Poor solution flow.	Jet is clogged.	Unclog the jet by removing and soaking in a vinegar and water solution. Scrub with a soft brush. Repeat if necessary.
	Blockage or clog in solution line.	Run System Maintainer through machine.
Pump continuously runs/pulses without producing correct pressure/flow.	Leak in solution line between pump and cleaning tool.	Find leak and repair or replace hose if necessary.
	Pump switch failure. This can be caused by various issues: <ul style="list-style-type: none"> <li>• Nozzle tip clogged or too small, causing rapid switch cycling.</li> <li>• Check valve failure between pump and heater causing hot water to return to pump and damage switch.</li> <li>• Pump inlet port is cracked causing pump to suck in air.</li> <li>• Damaged pump switch housing.</li> </ul>	Contact a Mytee Service Center.
Water is not pumping out of machine.	Vapor lock from turning on heater before pump.	Turn off the heater and allow the machine to cool completely. After machine has cooled, follow the machine startup procedure in section 2.6 of this manual.
Vacuum/pump/heater not turning on.	Bad power switch.	Check power switch by transferring wires from the switch in question to another switch. See if that switch turns on the component in question. Replace switch if necessary.
Vacuum not producing suction.	Vacuum tank is full.	Empty vacuum tank.
	Vacuum hose blockage.	Check for blockages in vacuum hoses inside and outside machine.
Blows water out exhaust.	Foam building up inside vacuum tank.	Use a defoaming solution in vacuum tank or use low foam or non foaming detergent/shampoo.
Water is not getting hot.	Automatic (black) sensor failure causing manual (white) sensor to trip.	Reset the manual (white) sensor by pressing the small button on it. If the manual sensor continues to trip, replace the automatic (black) sensor (part no. E573).



**Mytee, LLC**  
13655 Stowe Dr.  
Poway, CA 92064  
[www.mytee.com](http://www.mytee.com)

© 2022 Mytee, LLC