

Section B (2 points each)

- 6 Write the following number.

Five hundred eighty-three million, ten thousand, eleven

- 7 Arrange the digits 0, 0, 1, 2, 5, 6, 9 to form the greatest seven-digit odd number.

- 8 Write the missing number.

$$18,206,551 = 551 + \boxed{\phantom{000000}} + 18,000,000$$

- 9 842,700,000 has \_\_\_\_\_ hundred thousands.

Copyrights of Singapore Math Inc. Not to be reproduced.

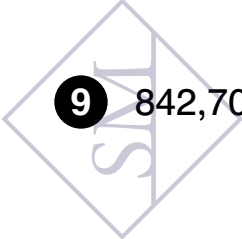

3  $4 \times 25 + 3 \times 12 =$

A 1,236

B 1,344

C 136

D 340

4 Which of the following expressions has the same value as  $20 + 10 - 12 \div 2 \times 3$ ?

A  $20 + 10 - 12 \div (2 \times 3)$

B  $(20 + 10) - (12 \div 2) \times 3$

C  $(20 + 10 - 12) \div 2 \times 3$

D  $20 + (10 - 12 \div 2) \times 3$

5 A baker made 30 muffins yesterday. He sold 21 muffins at \$3 each in the morning and the rest of the muffins at \$2 each in the afternoon. Which expression shows the total amount of money in dollars he received from selling the muffins yesterday?

A  $21 \times 3 + 30 - 21 \times 2$

B  $(21 + 13) \times (3 + 2)$

C  $21 \times 3 + 30 \times 2$

D  $(21 \times 3) + (30 - 21) \times 2$

Section B (2 points each)

11 Write the number that is 10,000 more than ten million.

12  $70,000,000 + 500,000 + 30,000 + 8,000 + 11 =$

13 Write  $>$ ,  $<$ , or  $=$  in the .

Sixty-two million, eight-five thousand nine  602,500,009

14 Use the given letters to put the numbers in order from least to greatest.

267,104,023

100,105,000

276,897,980

99,999,999

A

B

C

D

Copyrights of Singapore Math Inc. Not to be reproduced.

3 Han used  $\frac{2}{5}$  kg of chocolate chips to make cookies. How many grams of chocolate chips did he use?

A 250 g

B 200 g

C 400 g

D 25 g

4 What is the area of this figure?

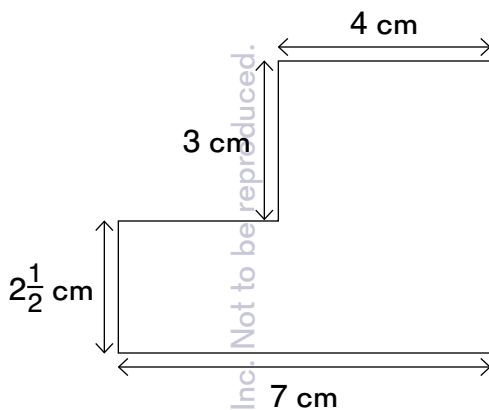

A  $17\frac{1}{2}$  cm<sup>2</sup>

B  $36\frac{1}{2}$  cm<sup>2</sup>

C  $5\frac{1}{2}$  cm<sup>2</sup>

D  $29\frac{1}{2}$  cm<sup>2</sup>

5 What is the area of Triangle ACD?

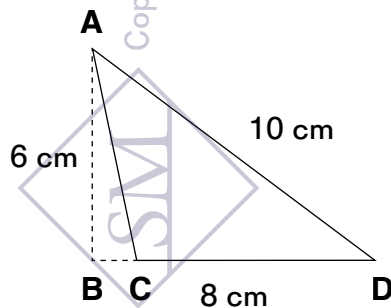

A 48 cm<sup>2</sup>

B 24 cm<sup>2</sup>

C 40 cm<sup>2</sup>

D 30 cm<sup>2</sup>

- 10 Find the volume of this solid figure.

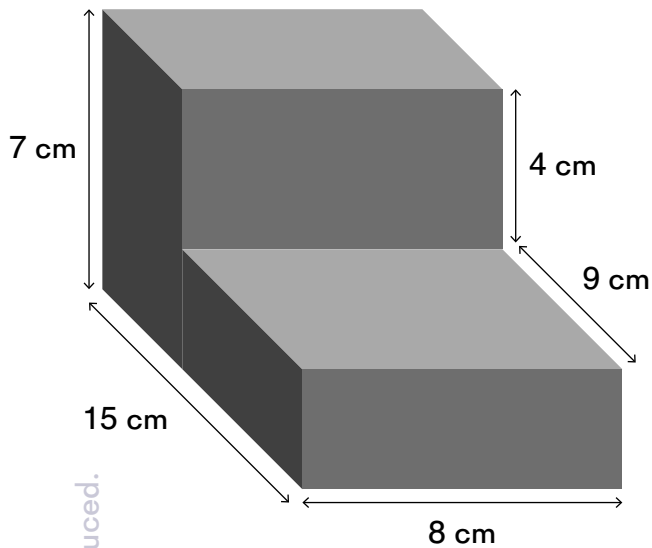

- 11 The water level in a rectangular tank with a brick in it is 19 cm. The tank's base is 20 cm by 30 cm. When the brick was removed from the tank, the water level decreased to 17 cm. What is the volume of the brick?

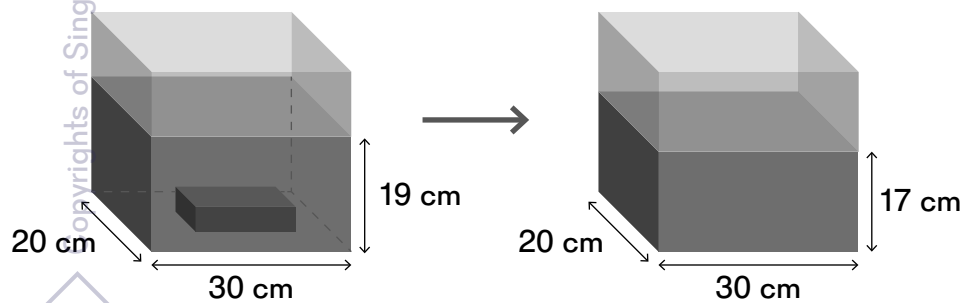

Name: \_\_\_\_\_

Date: \_\_\_\_\_



30

## Test B

### Chapter 8 Volume of Solid Figures

Section A (2 points each)

Circle the correct option: **A**, **B**, **C**, or **D**.

- 1** How many cubes were removed from the solid on the left to create the solid on the right?

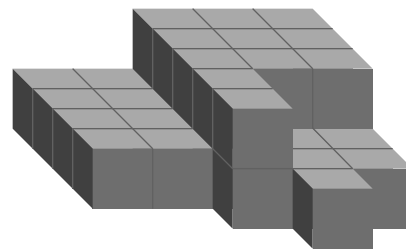
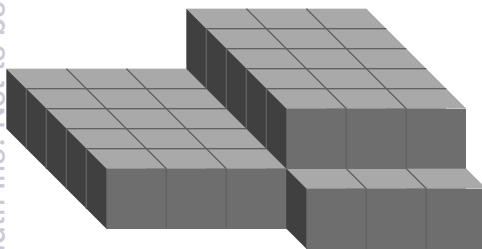

**A** 8

**B** 11

**C** 12

**D** 13

- 2** A rectangular box measures 12 cm by 10 cm by 9 cm. How many 1-cm cubes are needed to fill half of this box?

**A** 120

**B** 31

**C** 540

**D** 1,080

