

**inui**  
CLEANER • SMARTER • BRIGHTER™

# Stadium Pack LED Flood Light



Large Stadiums | Airports  
Parking Lots | Terminals  
Tennis Court | Golf Course  
Power stations | Commercial parks



## INUI LTD

Tel: +44 01509 266355

Web: [www.inui.co.uk](http://www.inui.co.uk) E-mail: [sales@inui.co.uk](mailto:sales@inui.co.uk)

ADD: INUI LED, Unit 4 Beaumont Court, Prince William Road, Loughborough LE11 5DA



# Specifications



240/300W

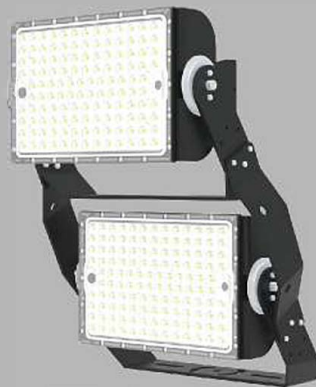

240/300W x2

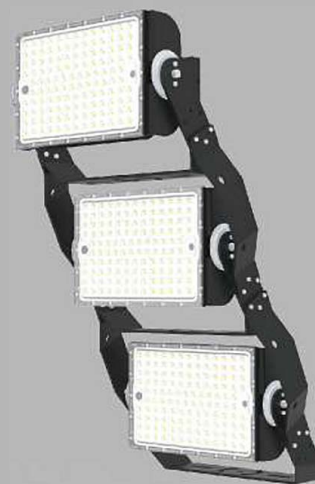

240/300W x3

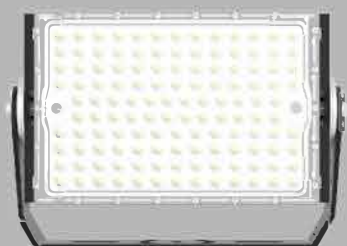

**WATTAGE**

240/300W

**CRI**

Ra>70

**CCT**

2700-6500K

**RATED VOLTAGE**

AC 100-240V 277V~, 50/60Hz

**POWER FACTOR**

>0.95

**BEAM ANGLE**

30°/60°/90°, Asymmetric

**IP GRADE**

IP66

**OPERATING TEMP**

-40°C ~60°C

MODEL REF	WATTAGE	LAMP EFFICIENCY	LAMP LUMINOUS FLUX	WEIGHT	SIZE
SPFL-240	240W	170LM/W±5%	40,800LM±5%	5.5KG±5%	344x184x238mm
SPFL-300	300W	160LM/W±5%	48,000LM±5%	6.0KG±5%	344x184x238mm

# EASY Combination



Light Shield



Side Bracket

## Single Module(240W, 300W)

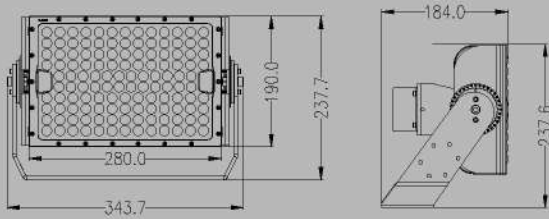

## Two Modules(480W, 540W, 600W)

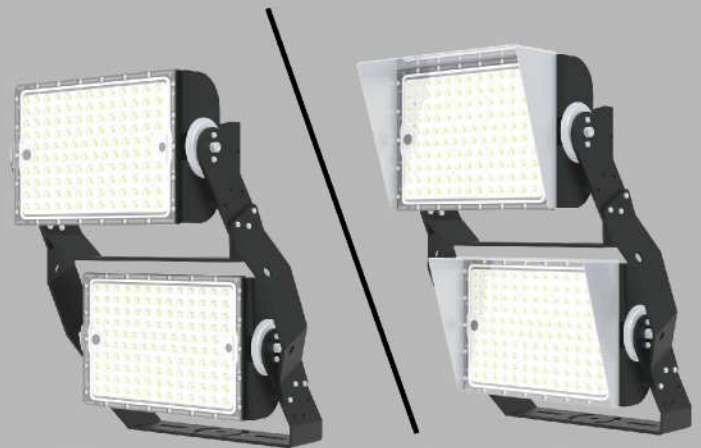
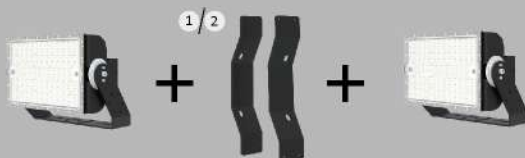
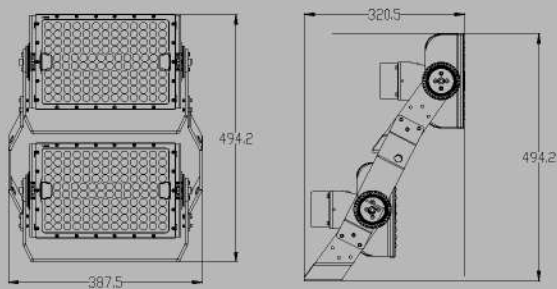

## Three Modules(720W, 780W, 840W, 900W)

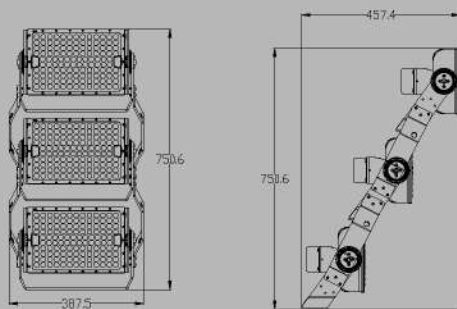

# Easy Aiming

Light through the laser pointer, illuminate any corner you want to illuminate.



# Lightning arrester(20KV)

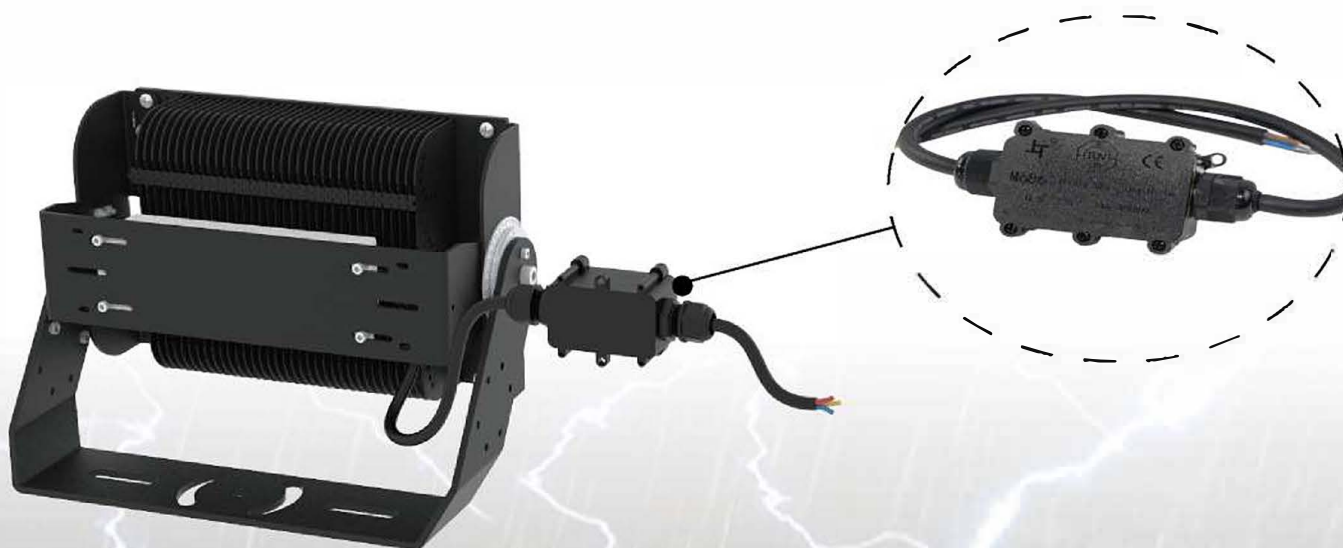

**IP66&IK10**



# Ultralight & Steady



High Efficiency

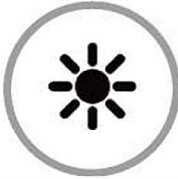

Various Angles



Efficient Thermal Management



Energy Saving



Long-life Span



Low Light Attenuation

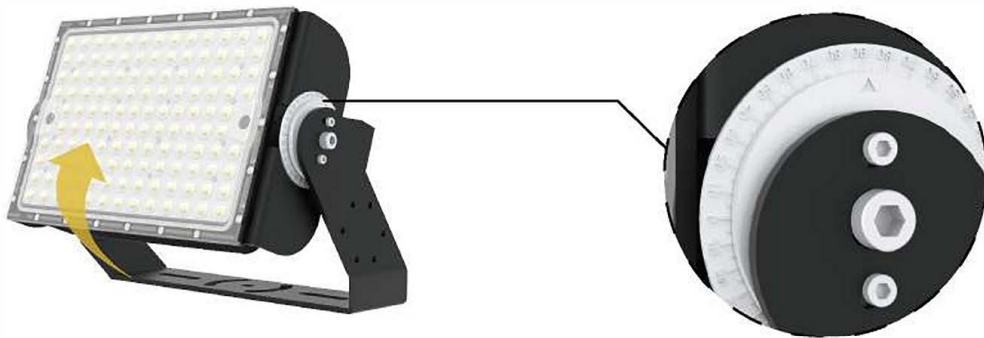

Module rotatable 360°



Curve screw hole, easy adjustment.



**Salt Spray Test**

The heat sink processed by oxidization and powder spraying so that it has good corrosion resistance.

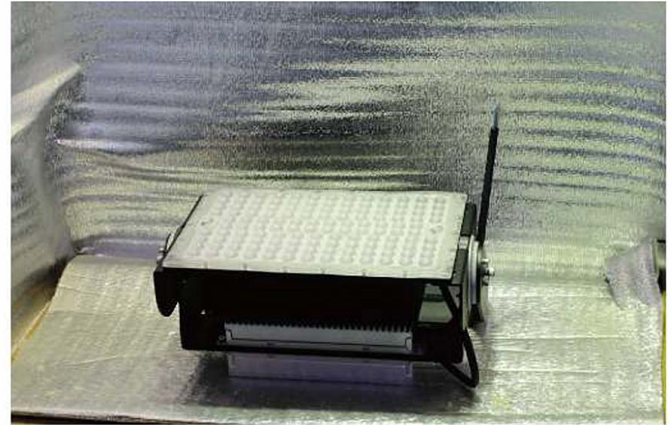

**UV Aging Test**

The test time is about 720 hours. After test the lamp working regularly, no discoloration appearance , no yellowing of the PC lens.



**High-Low Temperature Test**

The test equipment opening 2hours, keeping temperature  $<-40^{\circ}\text{C}$  ,the lamp working fine. The test equipment opening 4 hours,keeping temperature  $>60^{\circ}\text{C}$  , the lamp keep working fine.



**Waterproof Test**

Every lamp will be tested the water-proof at least 2 hours before shipment. The semiautomatic test line make it very efficient to shorten lead time.

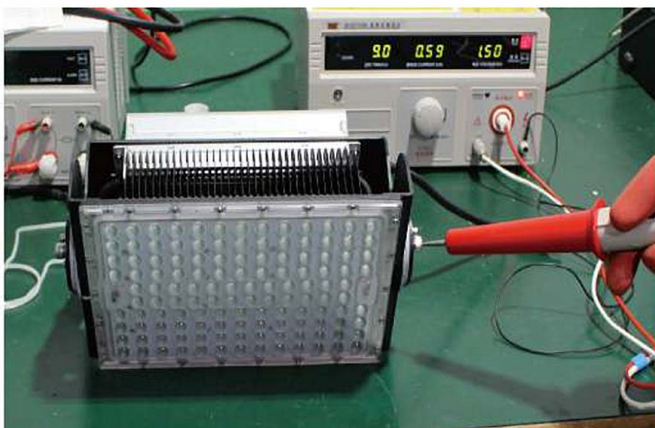

**Withstand Voltage Test**

Testing whether the withstand voltage is within the specified value, to avoid sudden voltage surges such as short circuit, operation error, fault, etc, causing breakdown or accidents.

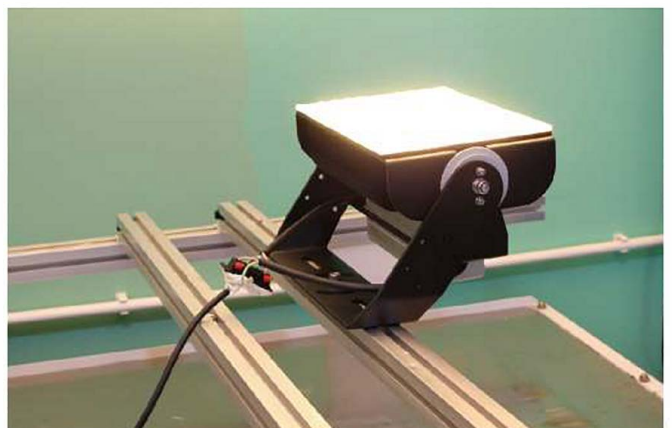

**Vibration Test**

Vibration test is a simulation of various vibration condition including transportation, installation and using, to ensure system robustness.

# DIALux & Light Distribution Optional

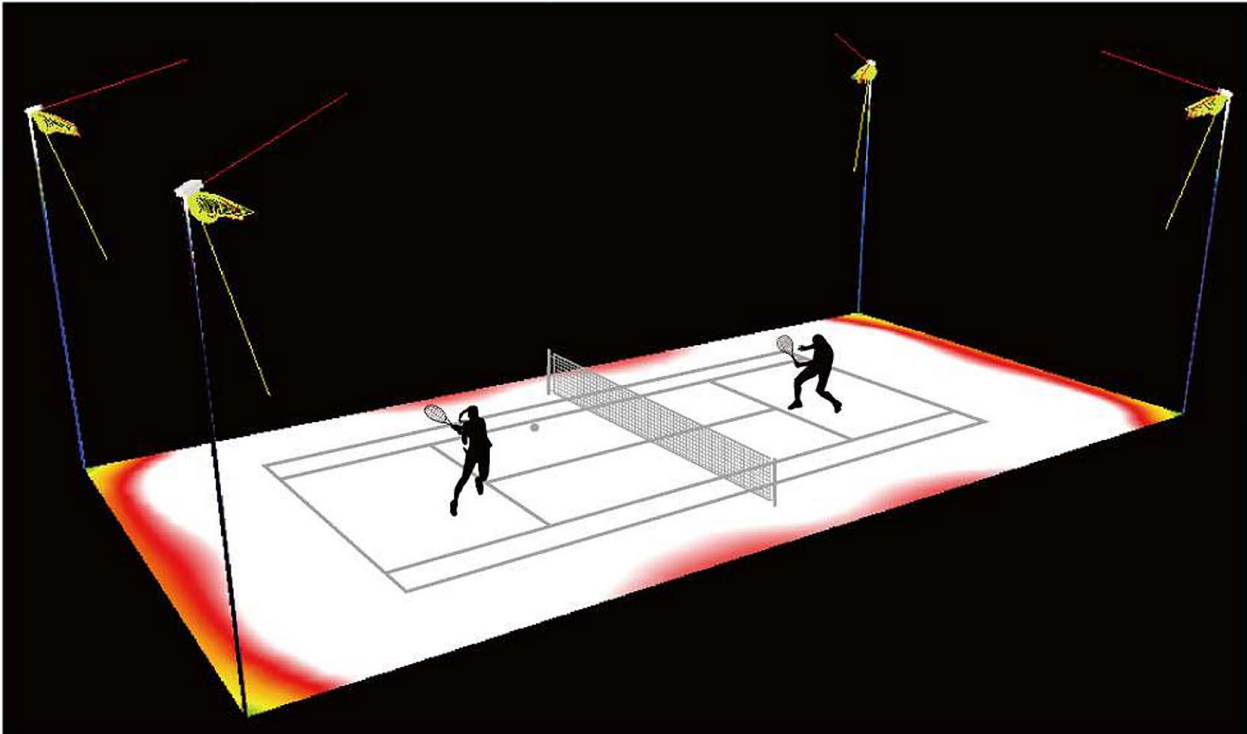

\* Standard tennis court, only 4pcs flood light uniformity  $U_0 > 0.85$ .

30°



60°



90°



Asymmetric-G4 Type





# Installation

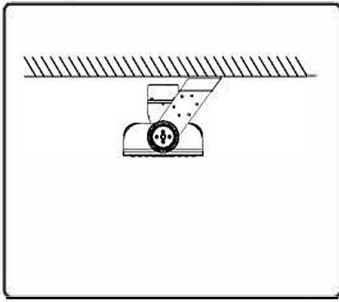

Ceiling Installation

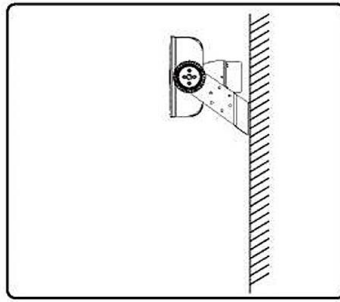

Wall Installation

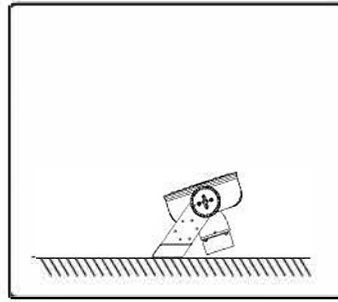

Ground Installation

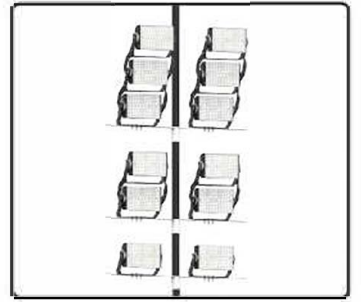

Pole Installation

# Application



Terminal



Airport



Stadium



Portable Lighting

# Packaging

WATTAGE	Size Of Box	Cross Weight	Size of Carton	Cross Weight	Box Quantity /Carton
240W	390x295x235mm	6.1kg±5%	605x410x505mm	25.4kg±5%	4
300W	390x295x235mm	6.6kg±5%	605x410x505mm	27.4kg±5%	4

