



MERCURY III

MODEL

LED stree light/Area Light

120W 150W

MAXIMUM ENERGY SAVINGS

A minimal total cost of ownership was the driving force behind the development of the Mercury range. It is equipped with LEDs and various dimming and remote management options for a dramatic reduction in energy consumption. It offers a very competitive alternative to luminaires equipped with traditional light sources such as high-pressure sodium lamps.



MERCURY III MODEL 120W 150W



STREET LIGHT SPECIFICATION SHEET



Using state-of-the-art technology, Mercury luminaires have been designed to fulfil the Future Proof concept. The photometric engine is IP 66 sealed to protect the LEDs and lenses from coming into contact with the outside environment and so maintain photometric performance over time.

► SLEEK DESIGN

The smooth, anti-static surface of the Mercury reduces dust, sand and avoid bird droppings and other material accumulation.

The UV protection and high strength anti-corrosion coating minimizes wear and increases the fixture's lifespan.

The LEDS Module and Driver can be easily removed, allowing real on-site replacement at the end of its service life in order to take advantage of future technological developments. This easy and rapid procedure reduces maintenance costs and contributes to reducing the total cost of ownership.

IP65 protection with durable electrostatic spray which apply to harsh outdoor applications. Tool free for open, reasonable layout design brings simple maintenance.

- Excellent for main roads, collecting roads, and roundabouts
- Complete illumination across the entire roadway
- No external reflectors required
- Safe for industrial applications
- High performance design
- Dramatic energy savings

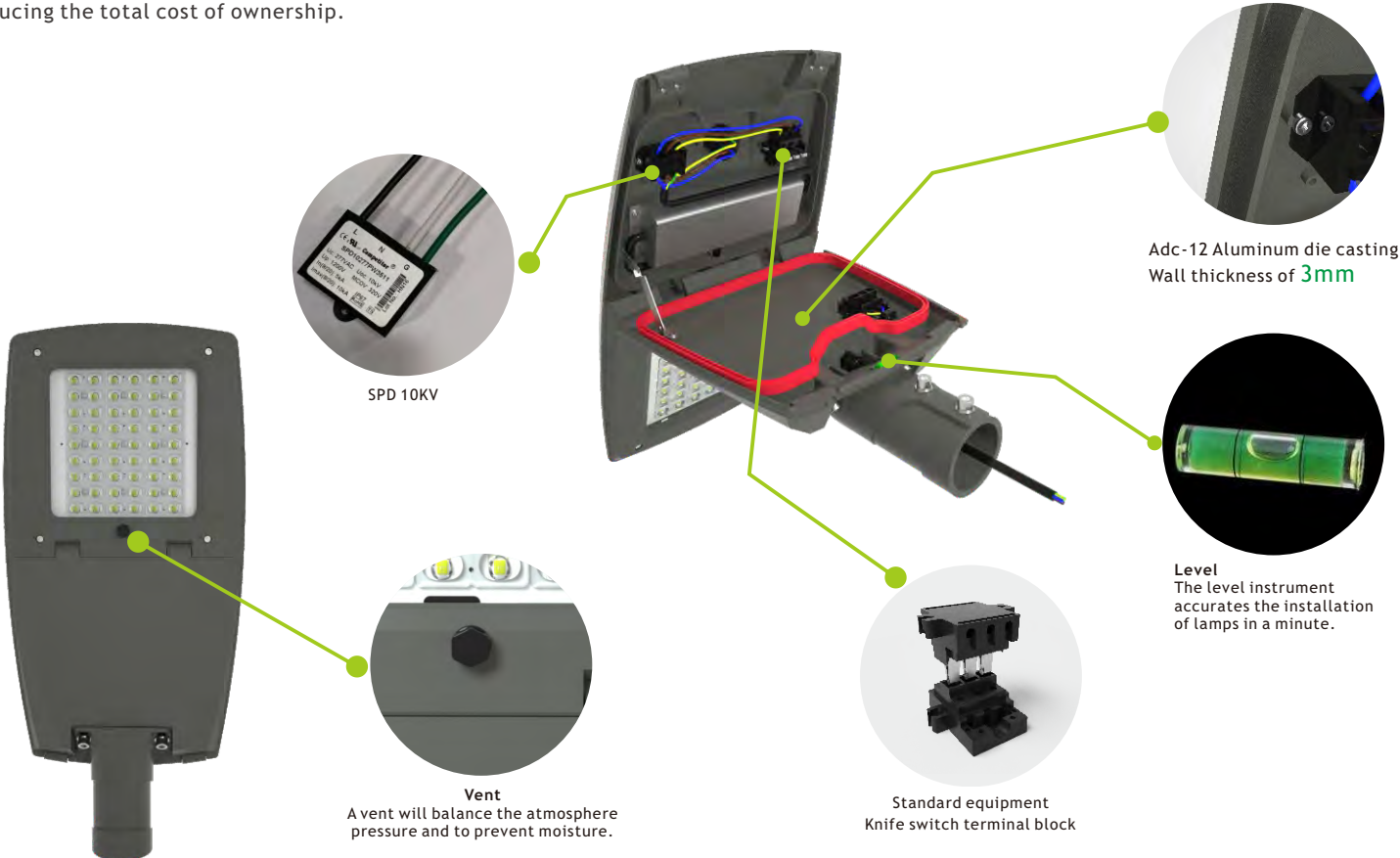



MERCURY III MODEL 120W 150W

STREET LIGHT SPECIFICATION SHEET

Product mercury large model

Model	INUIMESL-L120WLV(XXK)	INUIMESL-L150W-LV(XXK)
System Efficacy	160LM/W±3%	160LM/W±3%
Luminous Flux (Photometered)	19200 lm	24000 lm
Driver (EU AU)	ELG-150-48A	
Driver (US)	XLG-150-48A	
Distribution Type	Type II / Type III / Type V	
CCT	30K - 3000K 40K - 4000K	50K - 5000K 57K - 5700K
CRI	>70	
Surge protection device	10KV	

Electrical Characteristics (Luminaire)

	120W Typical	150W Typical
Power Consumption	120W Typical	150W Typical
Input Volt	100-277VAC	100-277VAC
Frequency Range	47-63Hz	47-63Hz
Power Factor	>0.95 / 230VAC	>0.95 / 230VAC
Total Harmonic Distortion	< 20%	< 20%
Dimming Function	1 - 10V Continuous / PWM DALI Optional	

Environmental

IP Rating	IP66
Impact Rating	Ik08
Salt Spray Tested	Yes
Operating Temp. Range	-30° ~ 122° F (-30° - 45° C)
Operating Humidity	15 - 90%
Thermal Management Type	Natural air cooling
Expected Lifespan	60,000 Hours to 70% Brightness
Material Composition (Body)	ADC-12 Aluminium Alloy (<0.1% copper content)
Material Composition (Optics)	PMMA (UV Resistance)
Material Composition (Cover)	Extra clear tempered glass protect
Mounting/Bracket Type	Post-top position, Side-entry position
Cable Gland	Pg11
Cable Ø Entry Range	10 -14mm

Product mercury large model

Model	INUIMESL-L120W-LV(XXK)	INUIMESL-L150W-LV(XXK)
Weight/ Packaging		
Luminaire Weight	6.7kg	
Packaging Dimensions	716 x 359 x 141cm (28.18 x 14.13 x 5.55 in)	
Packaged Weight	7.9kg (Standard)	

Certificates (Safety Standards)

ETL		✓
DLC(Standard)		✓
ENEC	IEC/EN60598-2-3 IEC/EN60598-1	✓
CB		✓
TUV CE-LVD		IEC/EN62778
Australian deviation		✓
TUV CE-EMC	En55014 EN61547 EN61000-3-2 EN61000-3-3	✓
SAA		✓
TUV IK08		✓
Salt Spray Test	24H	✓
IP66	By ENEC	✓
Flammability test	By ENEC	✓

Warranty

Warranty

5 years extended warranty optional



▼ DIMENSIONS

Length:	22.07 in (560 mm)	Height:	3.97 in (101 mm)
Width:	12 in (305 mm)	Height (w/photocell):	7.67 in (195 mm) Horizontal
		Height (w/photocell):	10.77 in (273.5 mm) Vertical

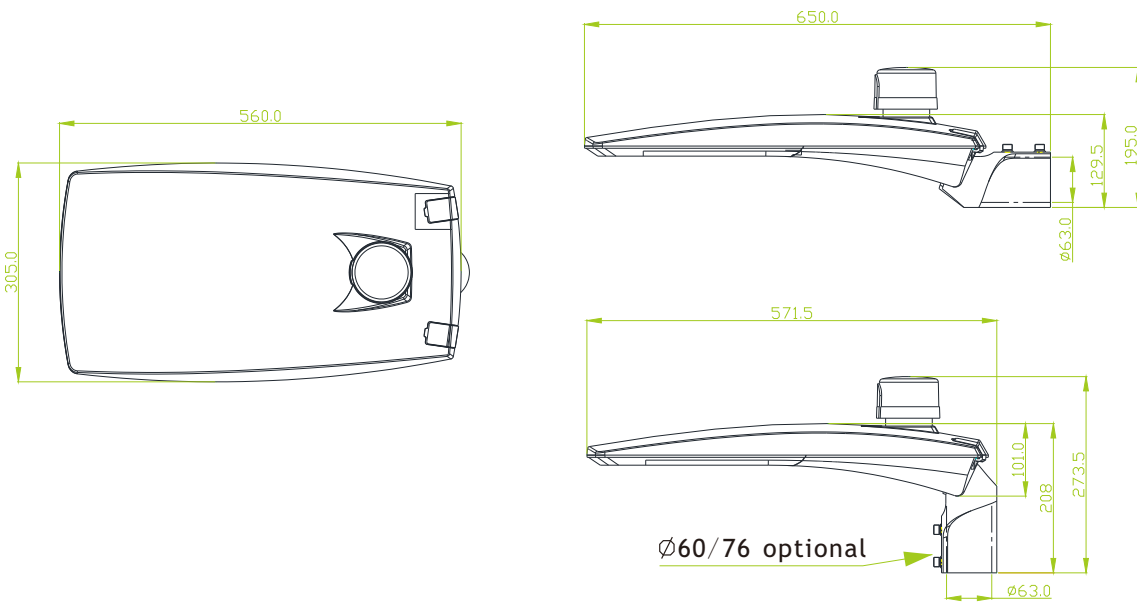

▼ MOUNTING OPTIONS

The Mercury fixture includes simple installation with convenient adjustability.

The Mercury fixture can be mounted horizontally or vertically with our universal slip fit system. Simply detach and rotate the slip fitter 180° to achieve the vertical orientation. Both orientation options include the ability to rotate 15° or more.



Horizontal MOUNTING
Post-top position
(rotates $\pm 15^\circ$)



Vertical MOUNTING
Side-entry position
(rotates $\pm 15^\circ$)

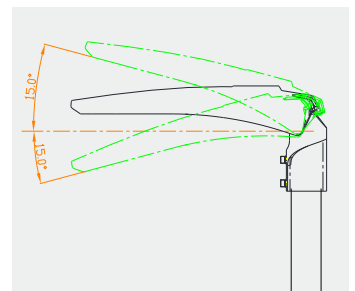
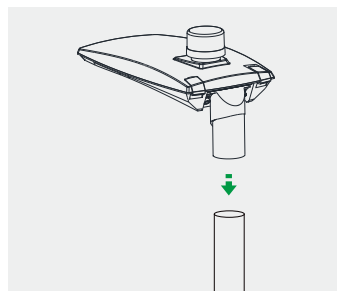
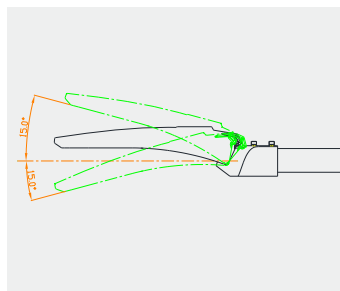
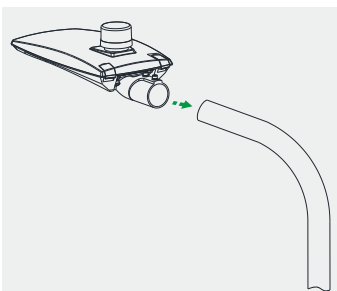



▼ PHOTOMETRIC OPTIONS

Type II (T2)
Distribution Type

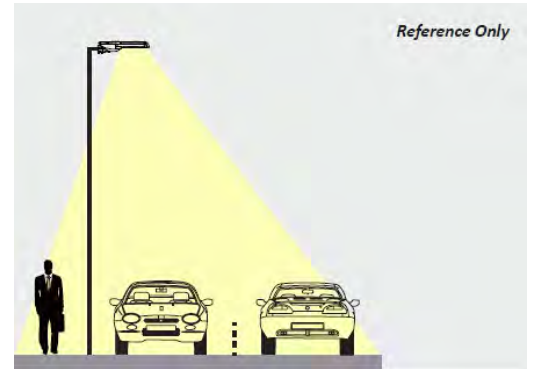
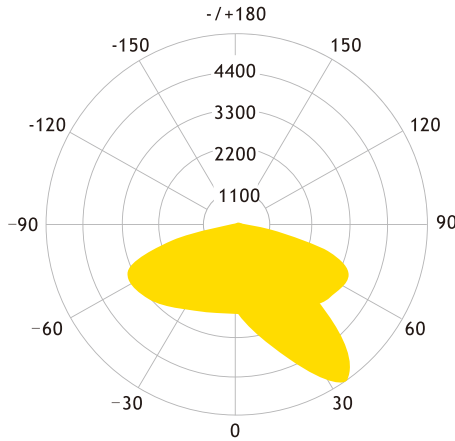
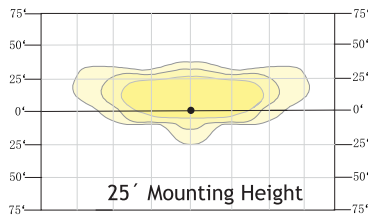

Type III (T3)
Distribution Type

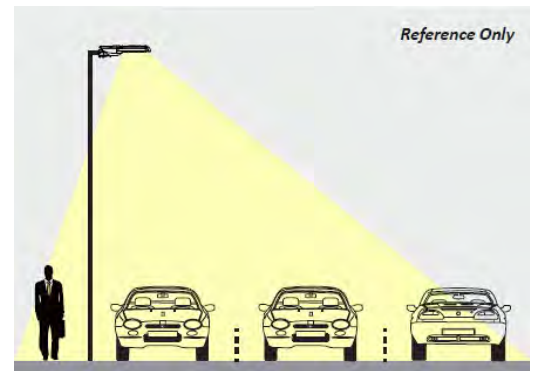
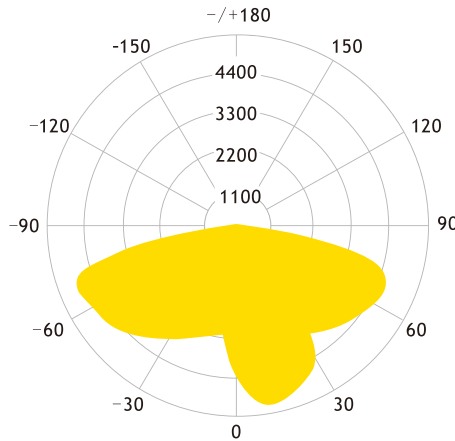
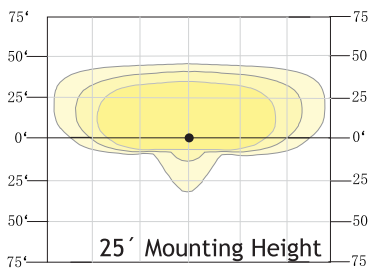

Type V (T5)
Distribution Type

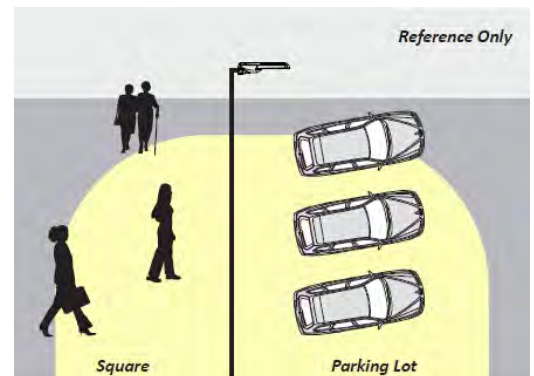
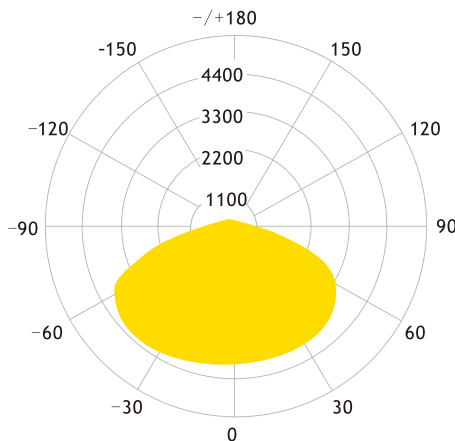
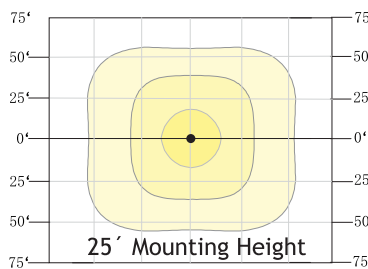



▼ ORDERING EXAMPLE

MERCURY STREET LIGHT

LARGE MODEL

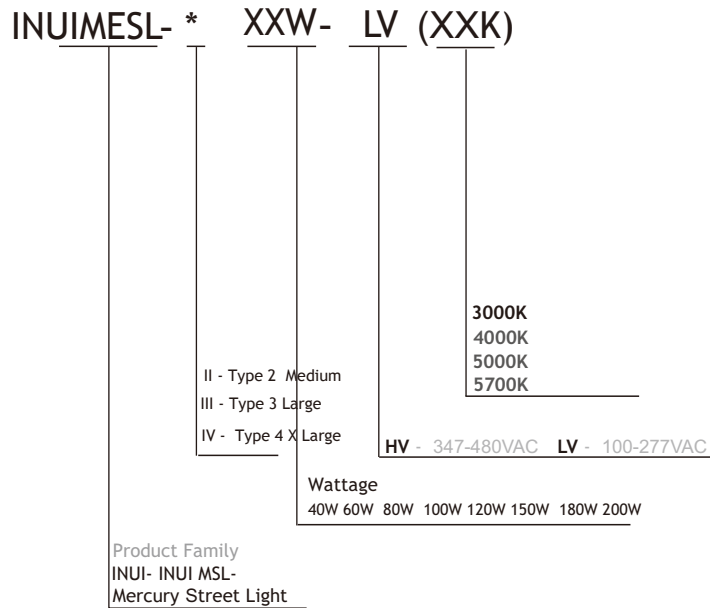

▶ ACCESSORY: **PHOTOCELL**

The Mercury Street Light Photocell integration controls the illumination of the fixture by detecting surrounding ambient light.

Photocell base comes pre-installed, twist lock cap included in package when shipped and ready to apply during assembly. Twist-Lock Photocell automatically turns lights On at Dusk and Off at Dawn.

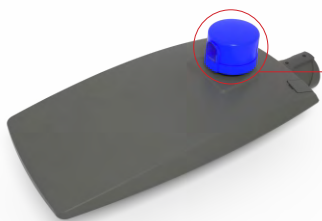

Photocell integration controls
 Photo-cell: TL1277
 120-277Volt Twist/Lock photocell

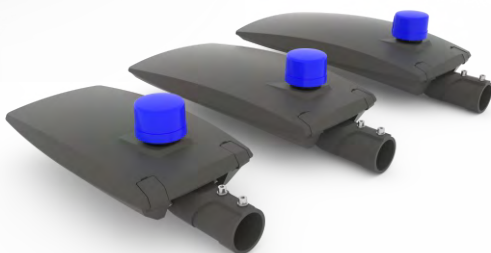

▶ ACCESSORY: **SURGE PROTECTION DEVICE**

The standard 100-277v fixture comes equipped with 10kA surge protection already integrated.

SPD surge protection devices is perfectly adapted for outdoor lighting to provide single phase protection for line/neutral, line/ground and neutral/ground in accordance with IEEE C62.41 2002 C High, UL1449 and IEC61643-11



▶ ACCESSORY: **MOUNTING**

The Mercury Street Light comes standard with a 76mm slip fitter.

Optional slip fitter mounts are available at 60mm, and 76mm diameters.

	MOUNTING	SIZE
	Mercury Slip Fitter 60mm	60mm
	Mercury Slip Fitter 76mm	76mm