

T400-400W Flood Light

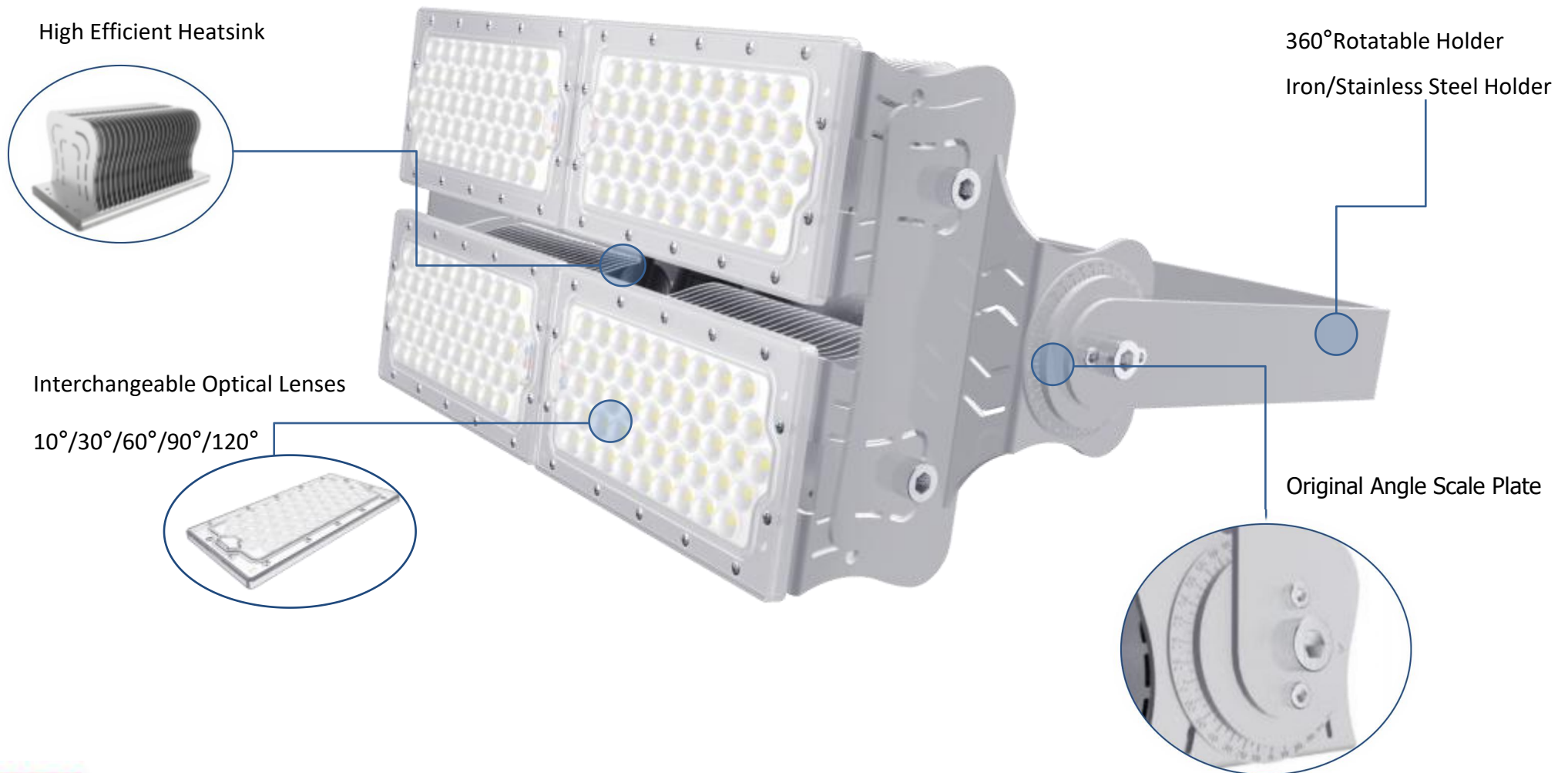

PHILIPS
LUMILEDS

160LM/W

➤ Product Parameter

➤ Wattage	400W
➤ Light Quantity	192PCS LED
➤ Driver	Meanwell
➤ CRI	Ra>70
➤ CCT	2700-6500K
➤ Rated Voltage	AC 90-305V 50/60Hz
➤ Power Factor	>0.95
➤ Net Weight	7.4kg±5%
➤ Operating Temp	-40℃ ~ 60℃
➤ Dimensions	485*219*334mm
➤ IP Grade	IP65

Lamp Luminous Flux	Beam Angle	Light Source
160LM/W	60 °/90° /120°	Lumileds
150LM/W	30°	Lumileds
120LM/W	10°	Cree



Significant cost savings



Reliable, high quality light



Long life –up to 50 000 hours



Up to 80-90% energy saving



Quick and easy installation



Environmentally friendly solutions

➤ Scope of Application

Designed to meet recommended luminance and illuminance requirements for high & low flood lighting applications in industrial and commercial buildings.

- Airport
- Factory
- Billboard
- Warehouse
- Shopping Malls
- Sports Field
- High Mast Light



➤ Feature

➤ Installation



- Suspension Installation
- Ground Installation
- Ceiling Installation
- Wall Installation

➤ Rotation adjustment design

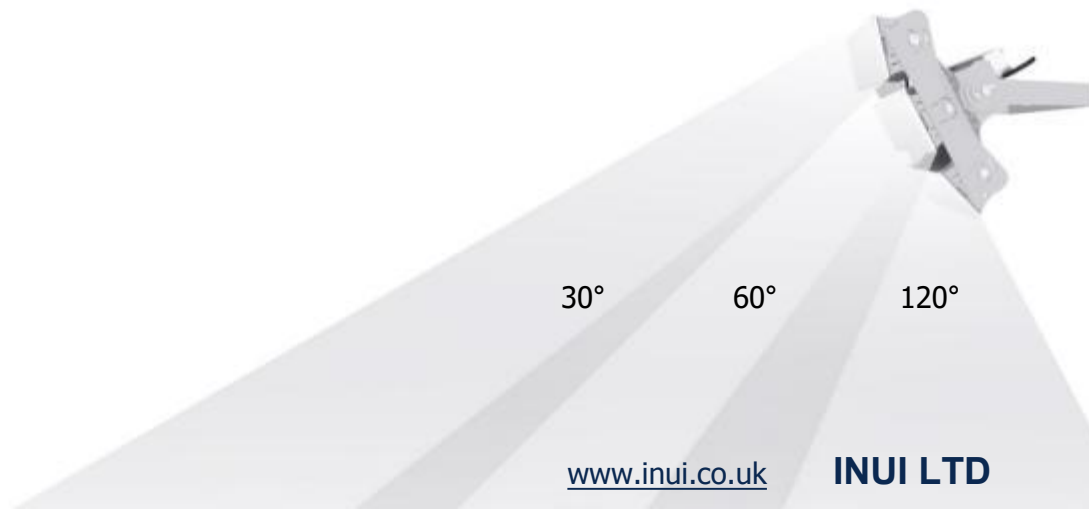

➤ Explosive View

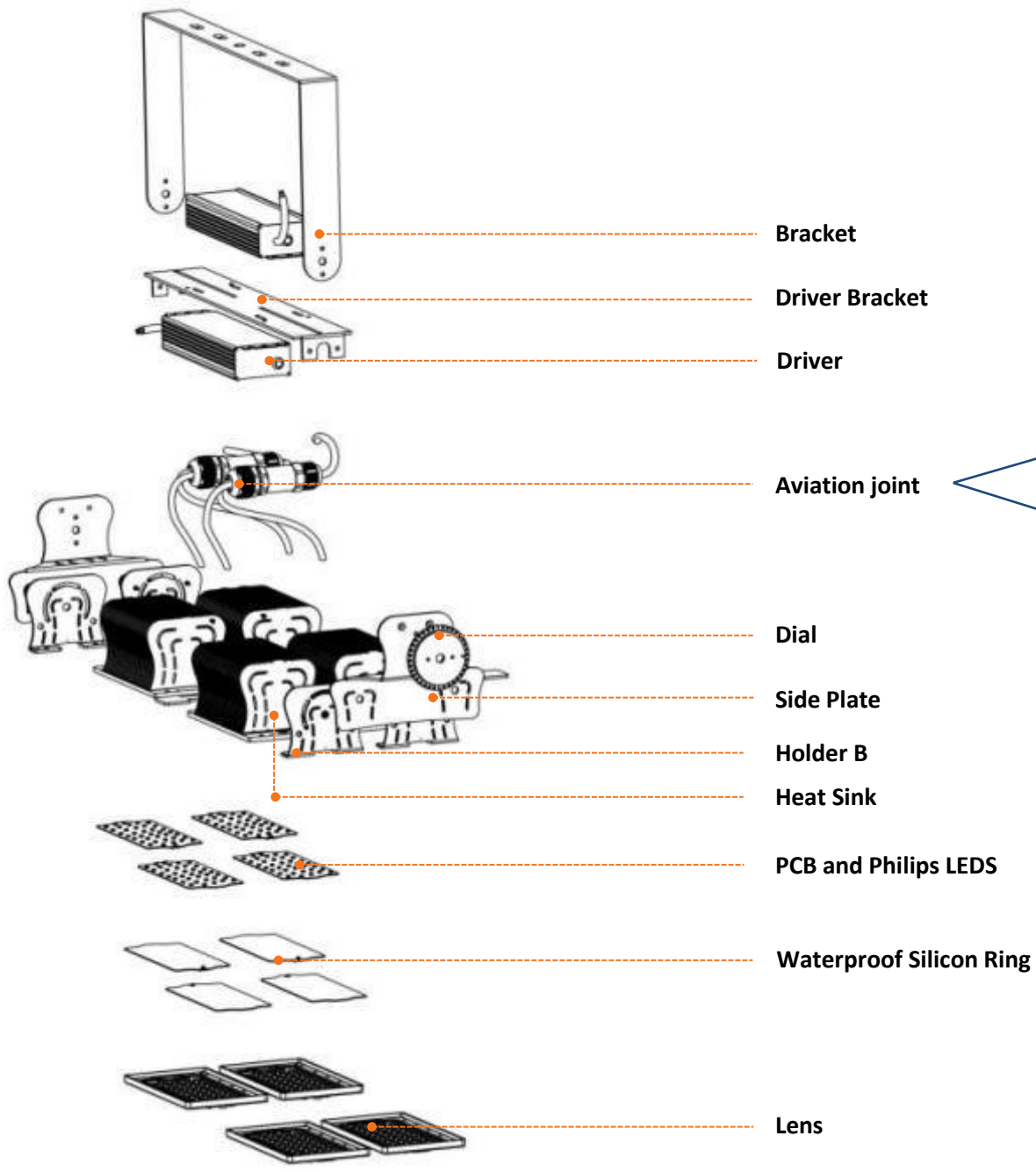

➤ Profession Light Distribution

➤ Dimensions

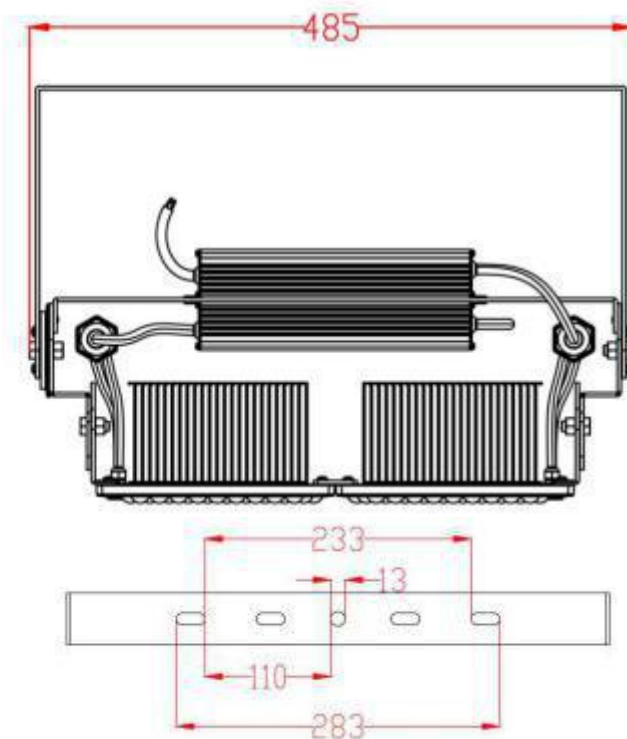
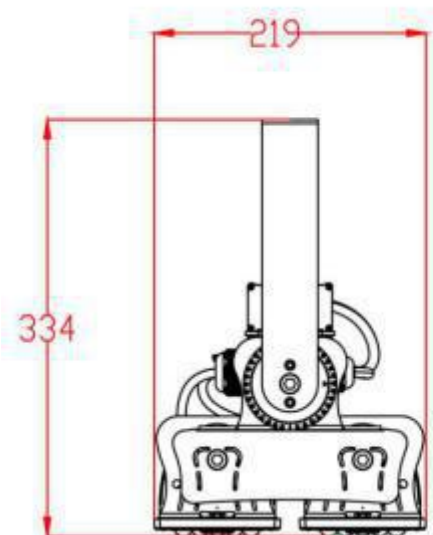
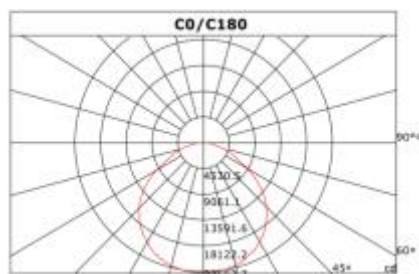
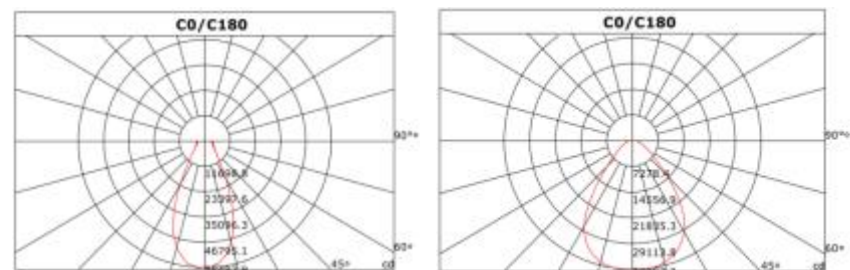
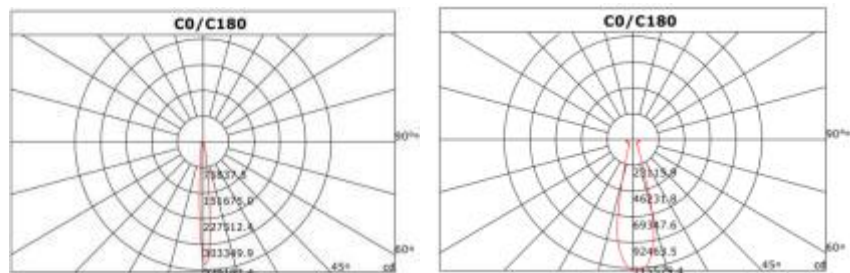

➤ Packaging

Inner box	Weight of Box	Outer Carton	Gross Weight of Carton	Box PCS /Carton
52*25*33.5cm	7.8KG	55*53*36cm	18.2KG	2