

T400-200W Flood Light

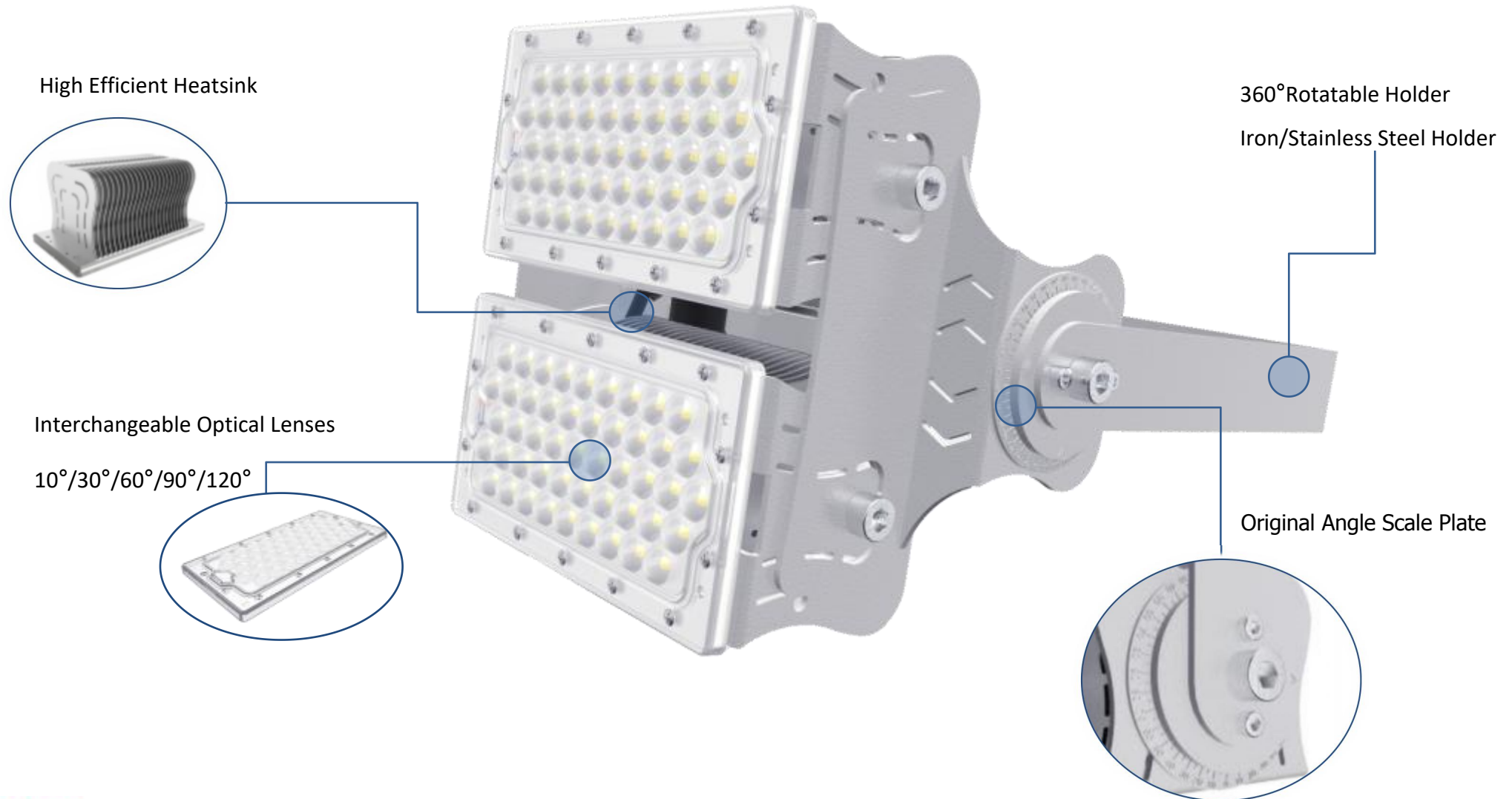

➤ Product Parameter

➤ Wattage	200W
➤ Light Quantity	96PCS LED
➤ Driver	Meanwell
➤ CRI	Ra>70
➤ CCT	2700-6500K
➤ Rated Voltage	AC 90-305V 50/60Hz
➤ Power Factor	>0.95
➤ Net Weight	4.2kg±5%
➤ Operating Temp	-40°C ~ 60°C
➤ Dimensions	291*219*334mm
➤ IP Grade	IP65

Lamp Luminous Flux	Beam Angle	Light Source
160LM/W	60 °/90° /120°	Lumileds
150LM/W	30°	Lumileds
120LM/W	10°	Cree



Significant cost savings



Reliable, high quality light



Long life –up to 50 000 hours



Up to 80-90% energy saving



Quick and easy installation



Environmentally friendly solutions

➤ Scope of Application

Designed to meet recommended luminance and illuminance requirements for high & low flood lighting applications in industrial and commercial buildings.

- Airport
- Factory
- Billboard
- Warehouse
- Shopping Malls
- Sports Field
- High Mast Light



➤ Feature

➤ Installation



- Suspension Installation
- Ground Installation
- Ceiling Installation
- Wall Installation

➤ Rotation adjustment design

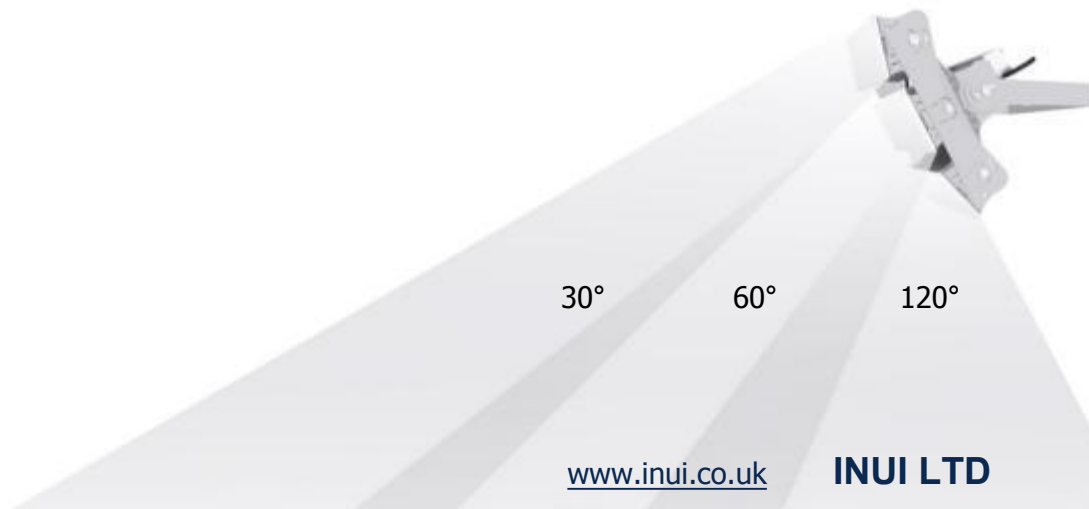

➤ Explosive View

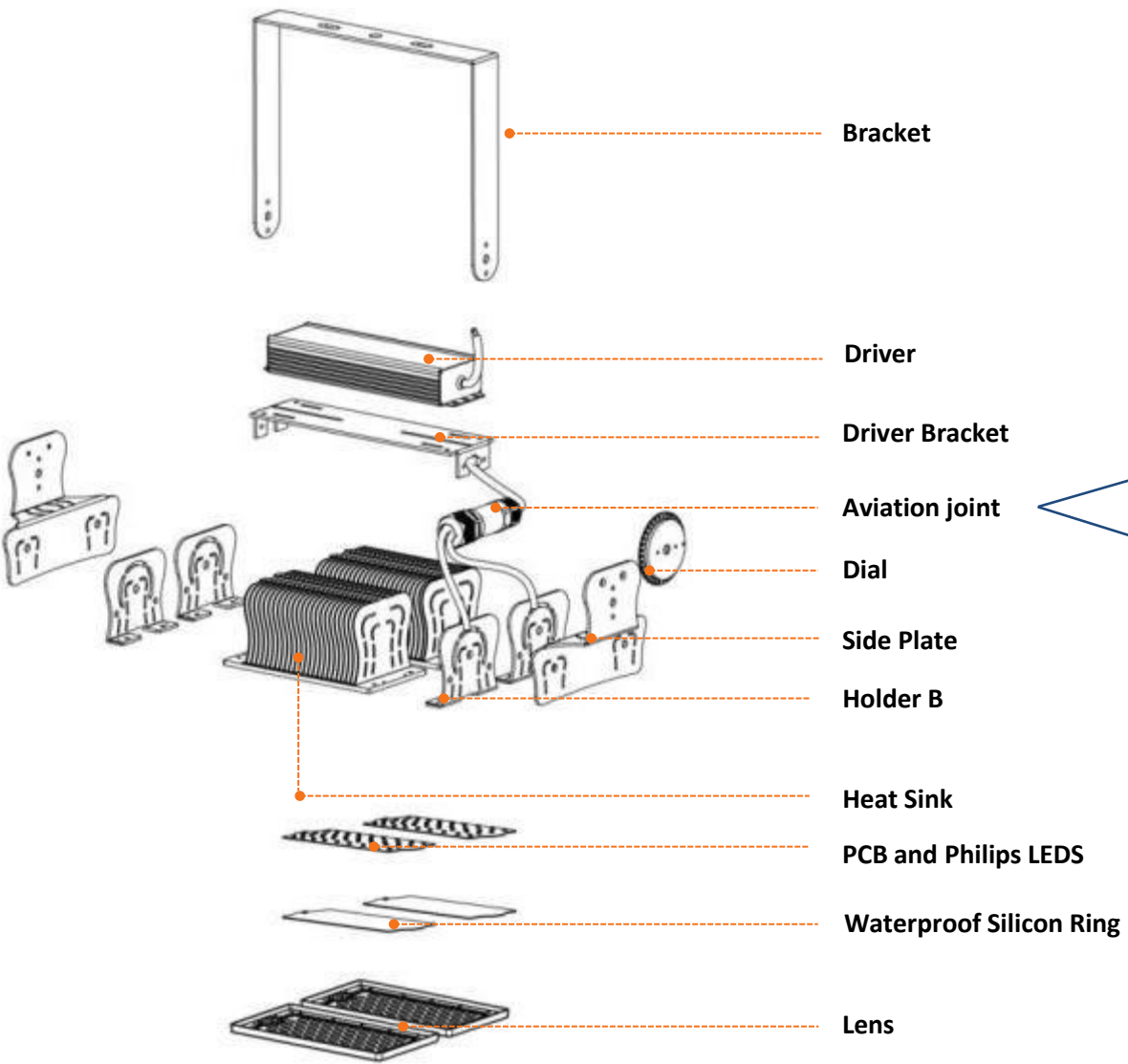

➤ Profession Light Distribution

➤ Dimensions

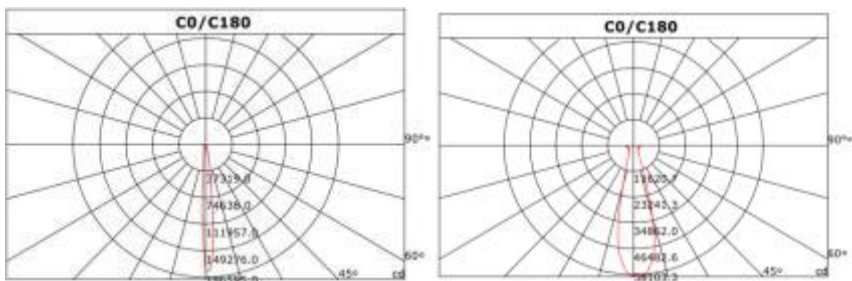

10°

30°

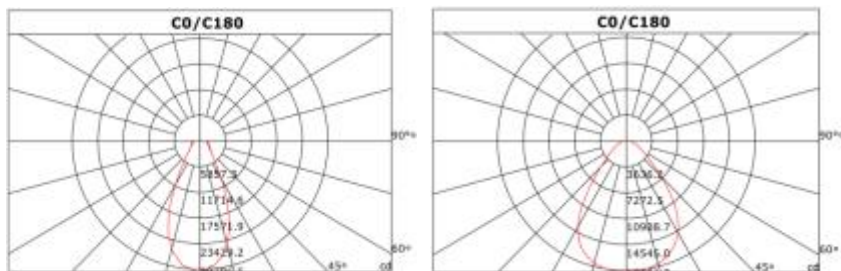

60°

90°

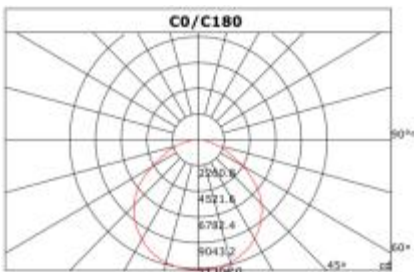

120°

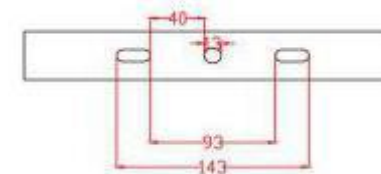
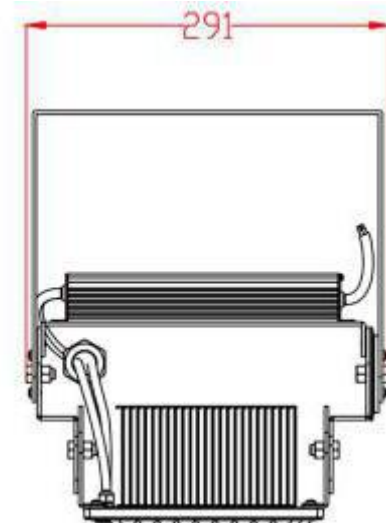
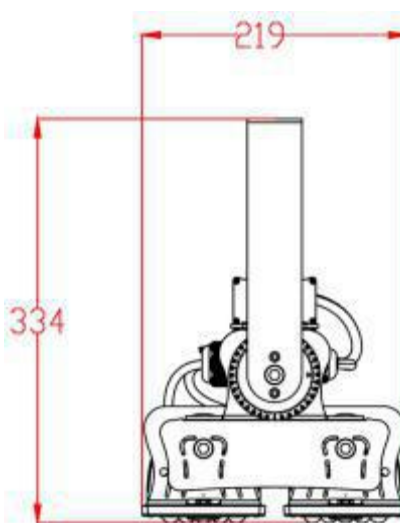

➤ Packaging

Inner box	Weight of Box	Outer Carton	Gross Weight of Carton	Box PCS /Carton
30*25*33cm	5.1KG	53*34*73cm	21.5KG	4