

MGF SERIES FLOOD LIGHT

Product description

INUI Marine Grade & explosion-proof floodlight is more than 50,000 hours lifespan, and the maintenance is reduced to 30% of the double input cost of the traditional lighting system. At the same time, it features a well designed optical system, high luminous efficiency and a variety of beam Angle options. ADC12 die-cast aluminum, 8mm tempered glass has better shock and vibration resistance. There are a variety of installation methods for your different projects. UL1598A North American marine anti-corrosion can be used in marine application and hazardous areas Zone 1&21, Zone 2&22.

Features

- Patent designed to be Curved Fin Shape, maximize the best heat transmit.
- Aluminum alloy (ADC12).
- Lens -tempered glass (8mm) shock & vibration resistant, Super clear, >90% light transmit.
- LED: LM80 certified, 130 lm/W +5, up to 26000lm.
- Meanwell LED Driver, >95% driver efficacy.
- Circuit design: 4KV/6KV Surge Protection power supply.
- Protection: IP68, high protection grade for waterproof and dust-proof.

Certification

ATEX:

- Ex II2G Ex eb mb op is IIC T4 Gb;
- Ex II2D Ex op is tb IIC T95°C Db;
- Certificate No: IEP 19ATEX 0714

IECEX:

- Ex ec IIC T4 Gc;
- IP68;
- Certificate No:
- IECEX UL 18.0046



(Please see the specification of UL HazLoc version)

Application

Wastewater treatment, oil and gas refineries, drilling rigs, offshore platforms, petrochemical facilities, chemical plants, coal mines, aviation bases, food plant, Pharmaceutical plant, beverage facilities, and where flammable vapors, gases, ignitable dusts, fibers or flyings are present.

Warranty

5-Year Standard Warranty

Lighting Distribution

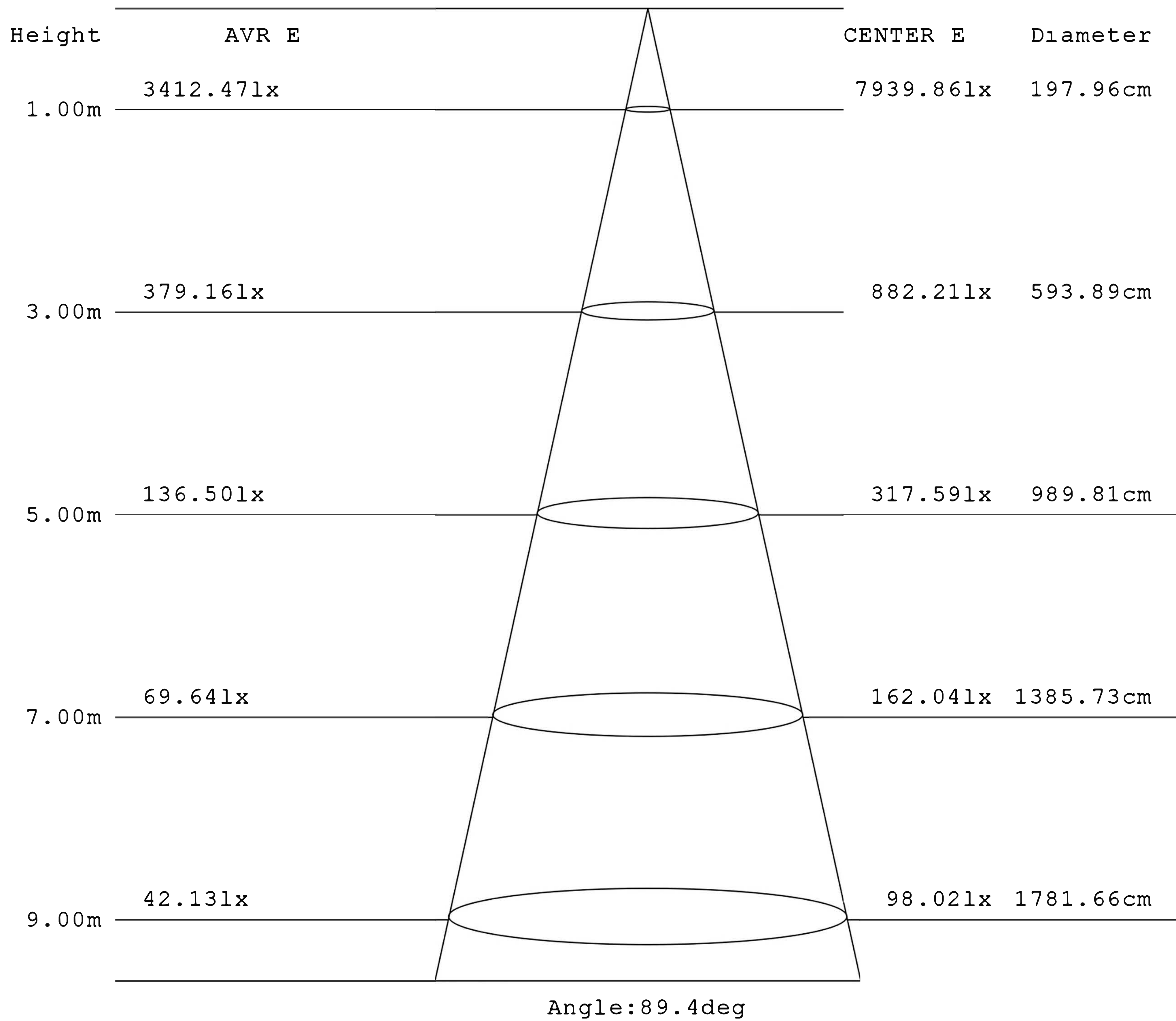
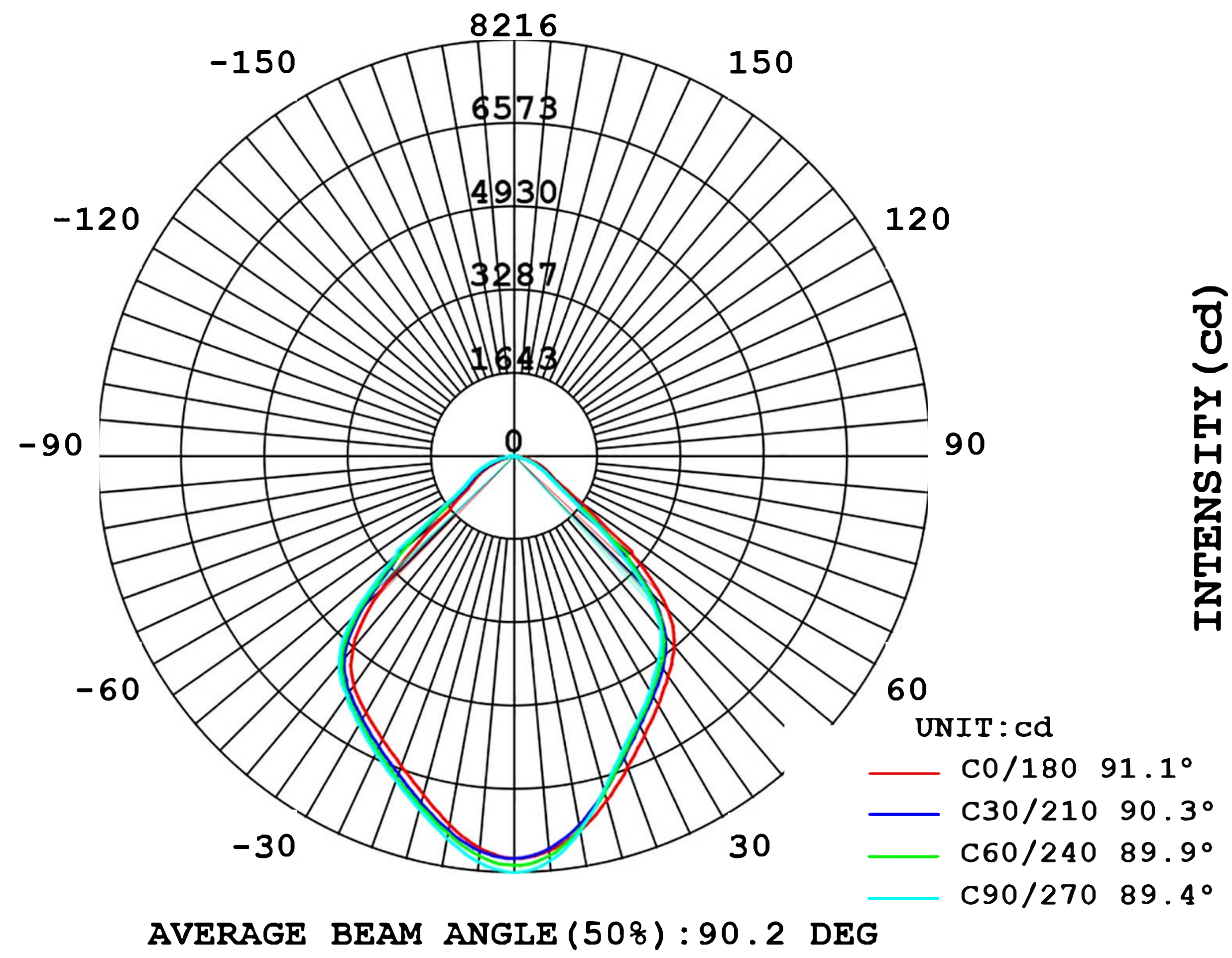

Size and packaging

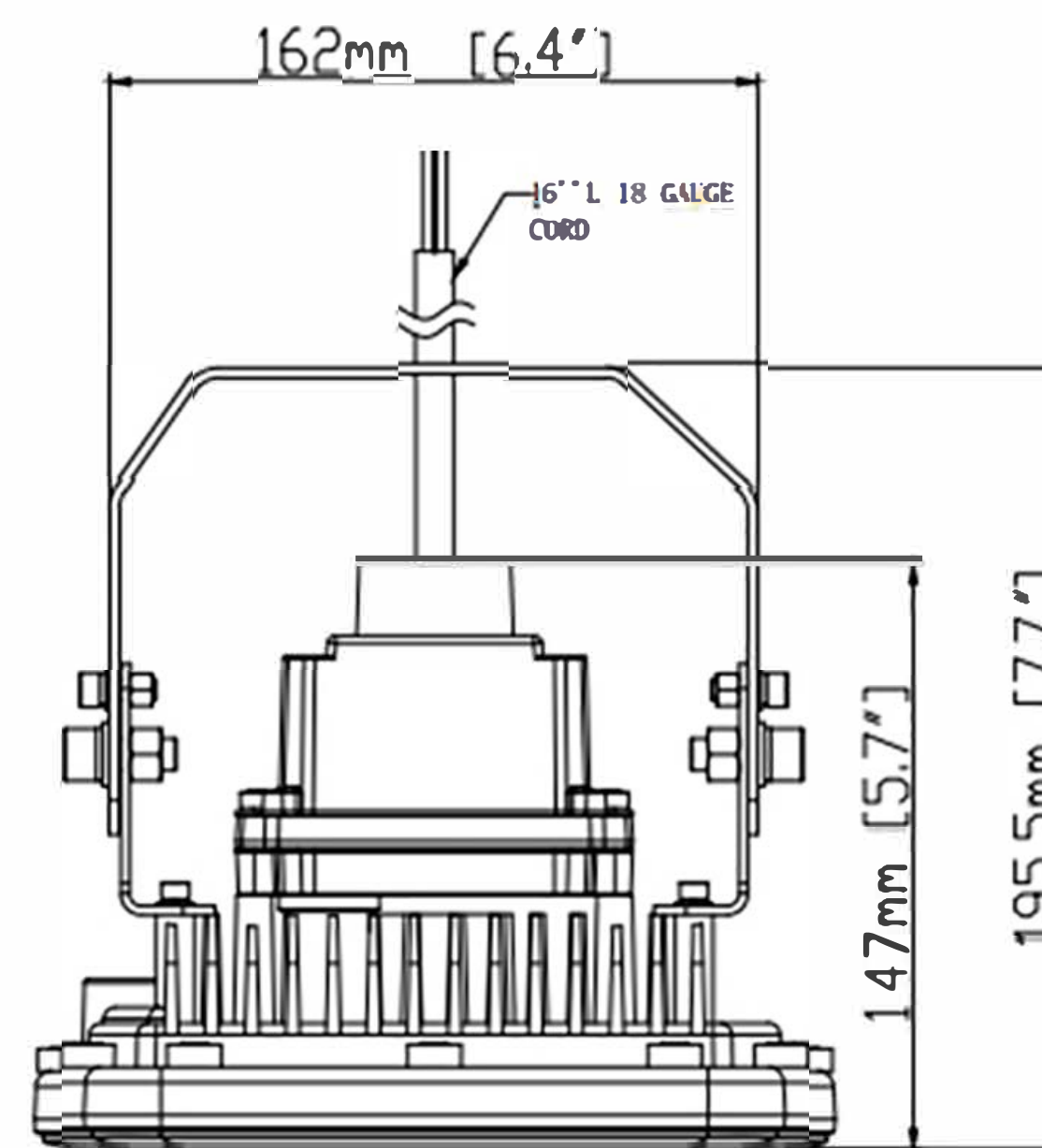
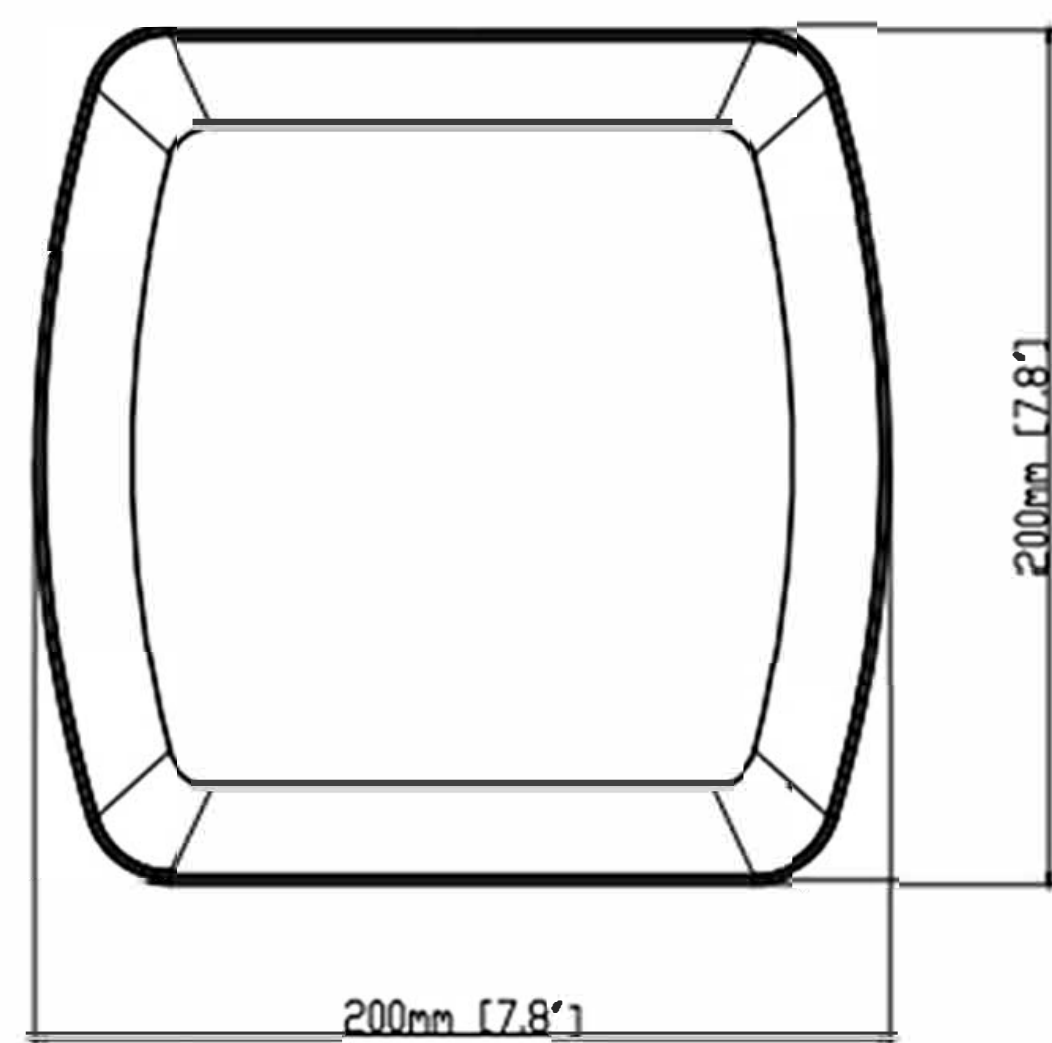

Product Model	Product Size	Carton Size	QTY/CTN	Net Weight	Gross Weight
MGF20	200 × 200 × 147mm(7.8×7.8×5.7)"	255 × 255 × 215mm(10×10×8.5)"	1	4 kg/8.8 lbs	5.0 kg/11.0 lbs
MGF30	200 × 200 × 147mm(7.8×7.8×5.7)"	255 × 255 × 215mm(10×10×8.5)"	1	4 kg/8.8 lbs	5.0 kg/11.0 lbs
MGF40	200 × 200 × 147mm(7.8×7.8×5.7)"	255 × 255 × 215mm(10×10×8.5)"	1	4 kg/8.8 lbs	5.0 kg/11.0 lbs

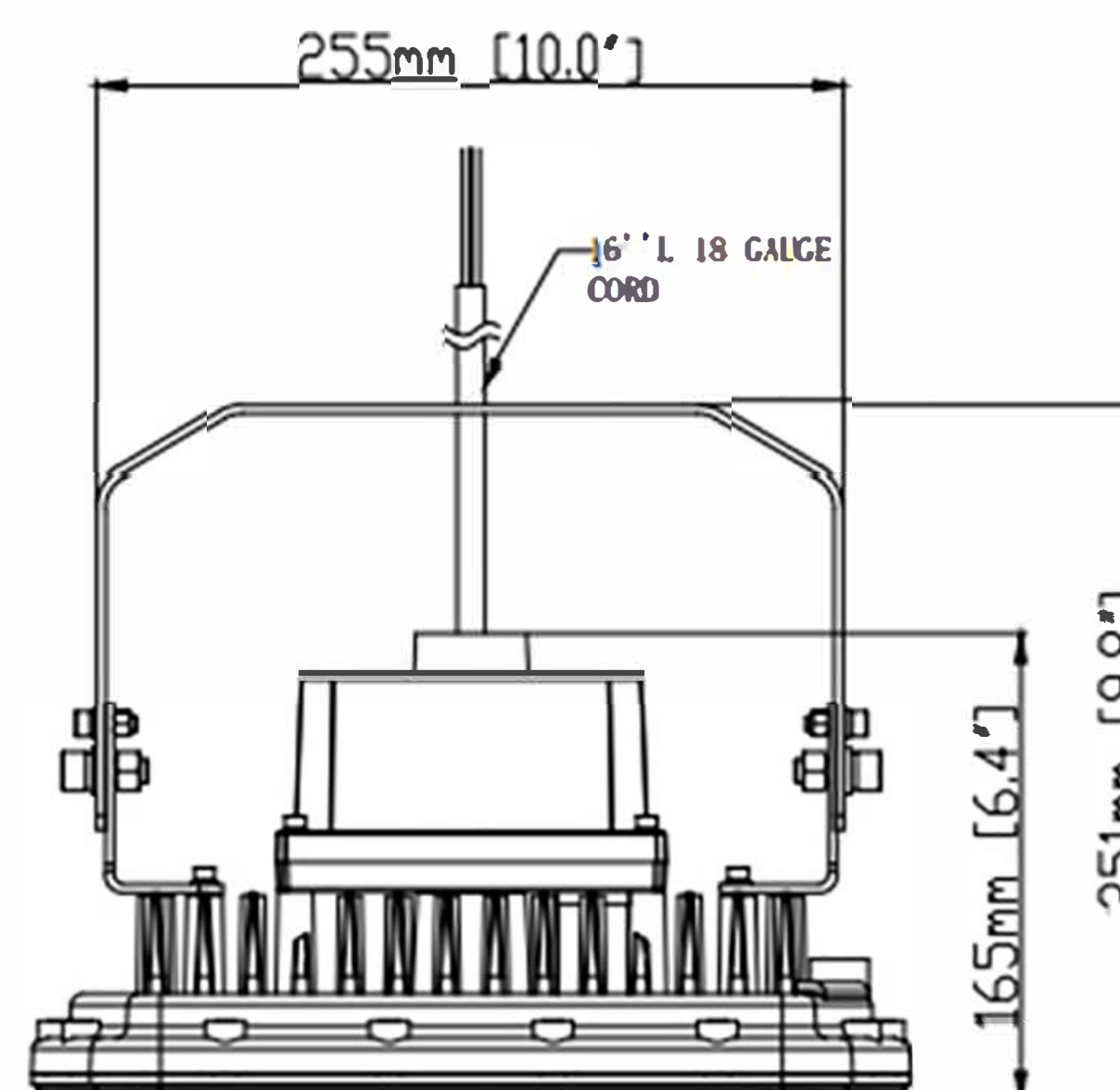
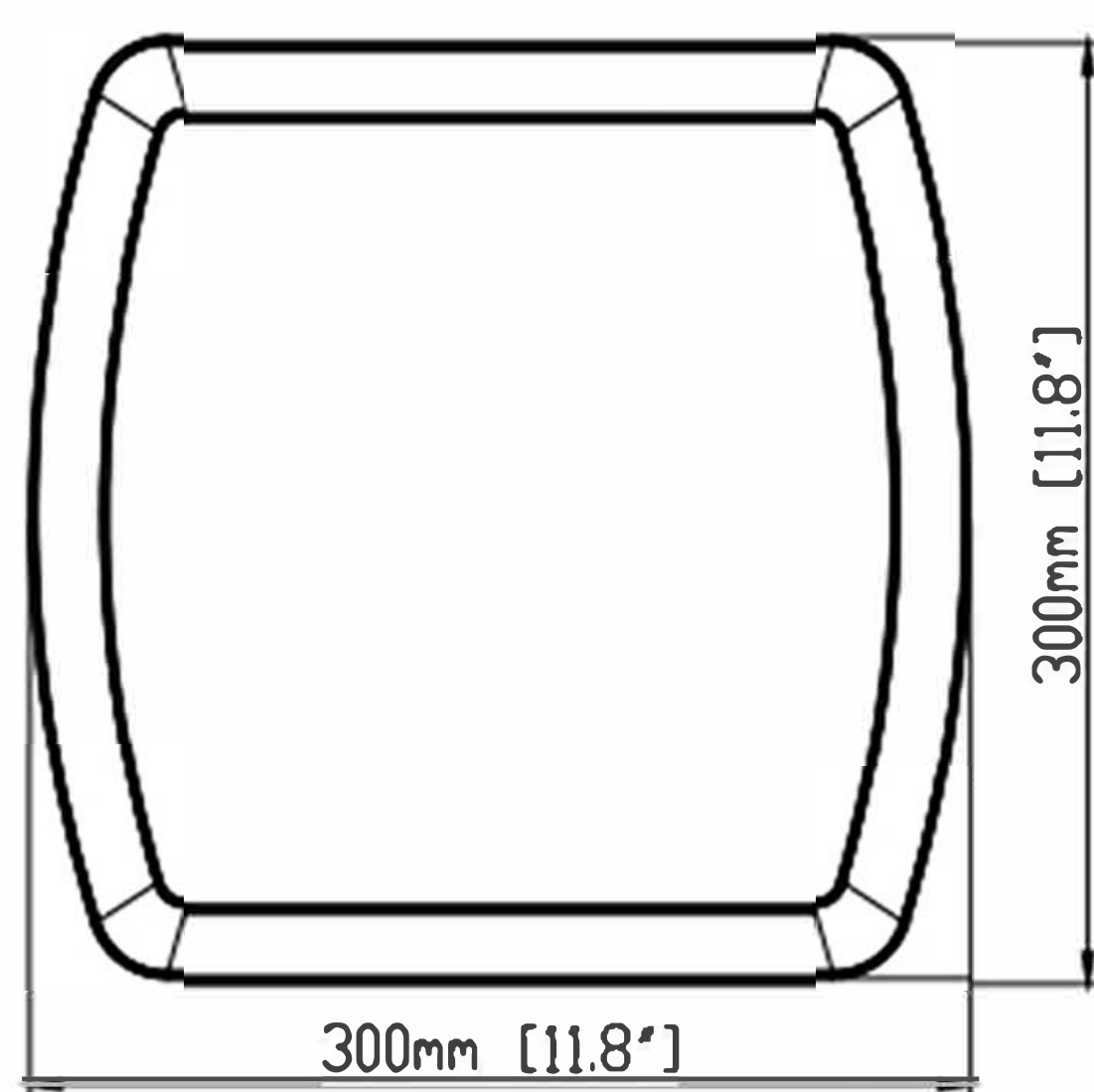

Product Model	Product Size	Carton Size	QTY/CTN	Net Weight	Gross Weight
MGF60	300×300×165mm(11.8×11.8×6.4)"	375×375×245mm(14.8×14.8×9.6)"	1	7 kg/16.5 lbs	9.0 kg/19.8 lbs
MGF80	300×300×165mm(11.8×11.8×6.4)"	375×375×245mm(14.8×14.8×9.6)"	1	7 kg/16.5 lbs	9.0 kg/19.8 lbs
MGF100	300×300×165mm(11.8×11.8×6.4)"	375×375×245mm(14.8×14.8×9.6)"	1	7 kg/16.5 lbs	9.0 kg/19.8 lbs

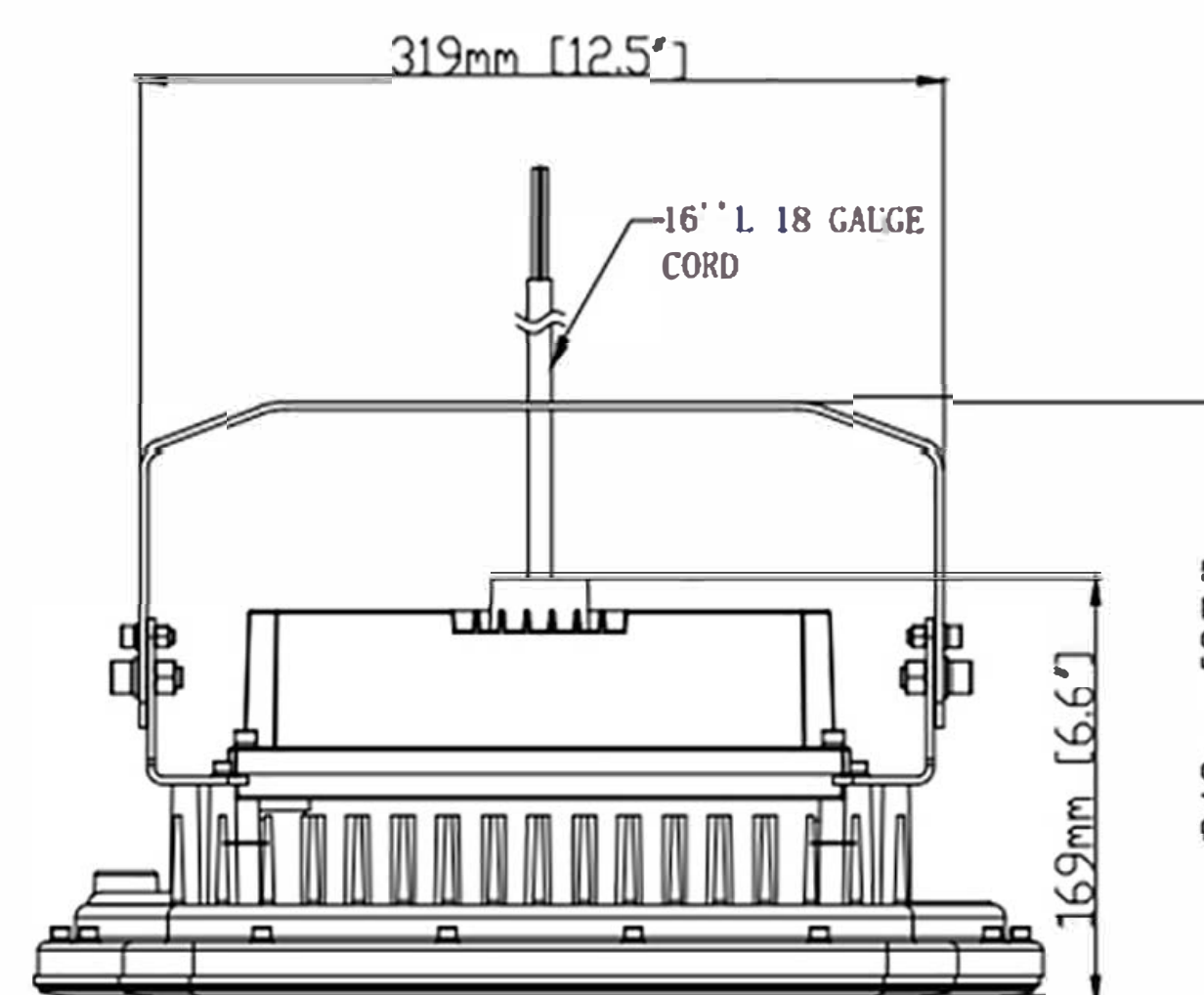
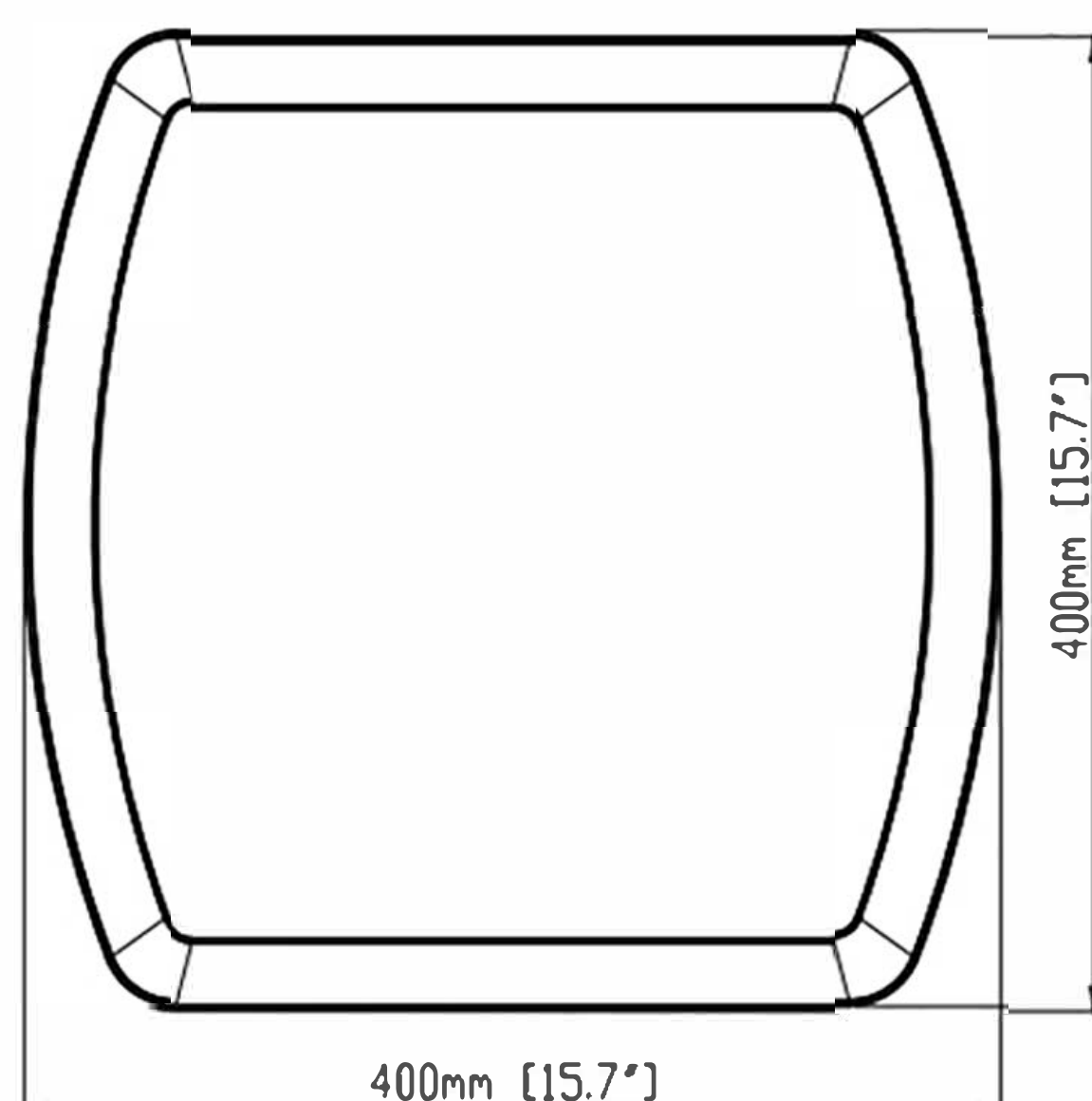

Product Model	Product Size	Carton Size	QTY/CTN	Net Weight	Gross Weight
MGF120	400×400×169mm(15.7×15.7×6.6)"	470×470×250mm(18.5×18.8×9.8)"	1	10.5 kg/23.1 lbs	12 kg/26.4 lbs
MGF150	400×400×169mm(15.7×15.7×6.6)"	470×470×250mm(18.5×18.8×9.8)"	1	10.5 kg/23.1 lbs	12 kg/26.4 lbs
MGF180	400×400×169mm(15.7×15.7×6.6)"	470×470×250mm(18.5×18.8×9.8)"	1	10.5 kg/23.1 lbs	12 kg/26.4 lbs
MGF200	400×400×169mm(15.7×15.7×6.6)"	470×470×250mm(18.5×18.8×9.8)"	1	10.5 kg/23.1 lbs	12 kg/26.4 lbs

Technical parameter

Product Model	MGF20/30/40	MGF-60/80/100	MGF120/150/180/200
Type	LED Marine & Explosion proof Flood Light		
luminous efficiency	110~130 lm/W	110~130 lm/W	110~130 lm/W
Power(W)	20W/30W/40W	60W / 80W / 100W	120W / 150W / 180W / 200W
Voltage-Frequency	100-277Vac 50-60Hz		
Color Temp	5000K (Provides 2700K to 6500K)		
CRI(Ra)(typ.)	≥70		
Luminous Flux (lm)	2400 / 3600 / 4800	7200 / 9600 / 12000	14400/ 18000/ 21600 24000
Power Supply	Meanwell HLG Series (Meanwell XLG Series for 200W)		
Beam Angle	15°, 60°, 90°, 108°, 120°		
Power Factor	>0.95		
Rated Lifetime-L70 (hrs.)	50,000		
THD	<10%		
Operating temperature	-40° C to +40° C		
Entry Size	M25X1.5 (Standard), M26X1.5 or NPT 3/4"-14 (Optional)		
Cable	Three-core rubber cable, IEC (CE) certification, with 0.5m cable (Standard)		

Product display



Front



Side



Back

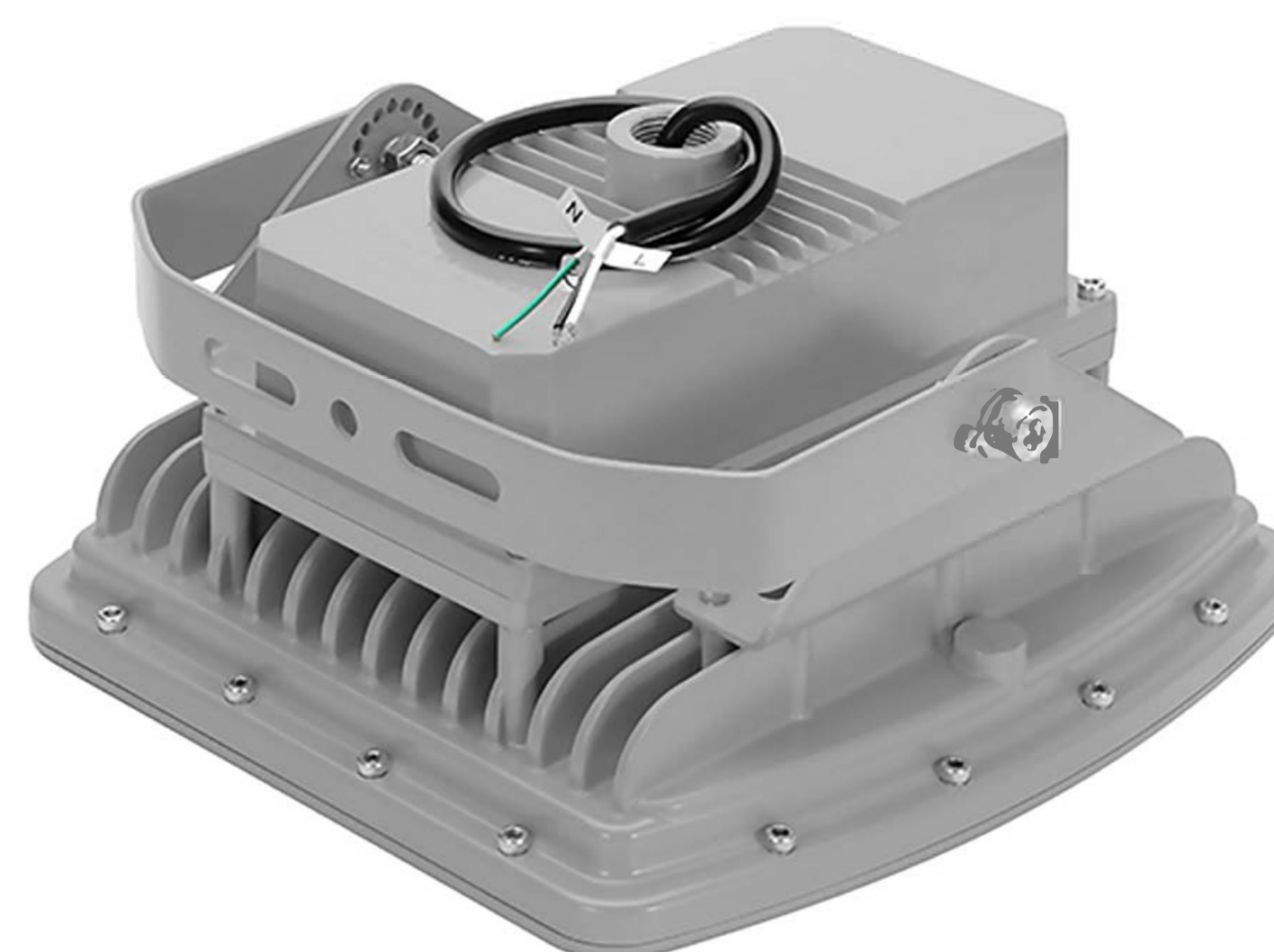

Top

Installation method

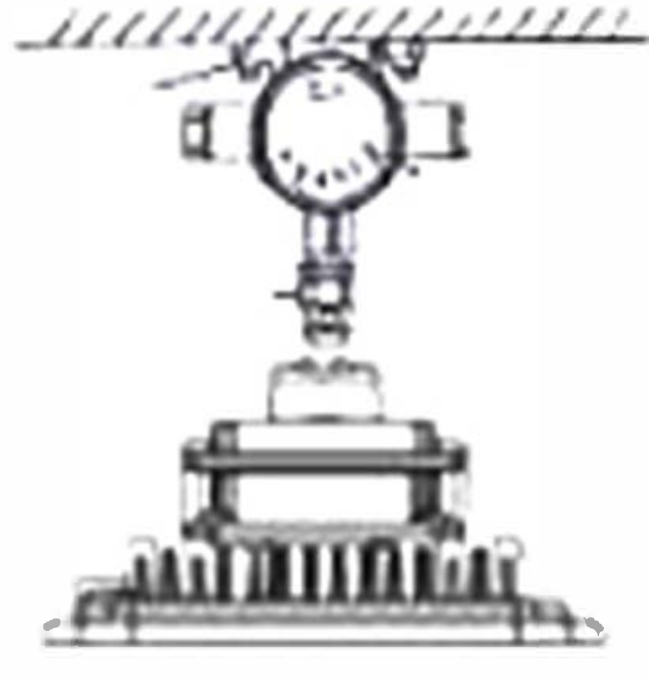

A. Ceiling Mount

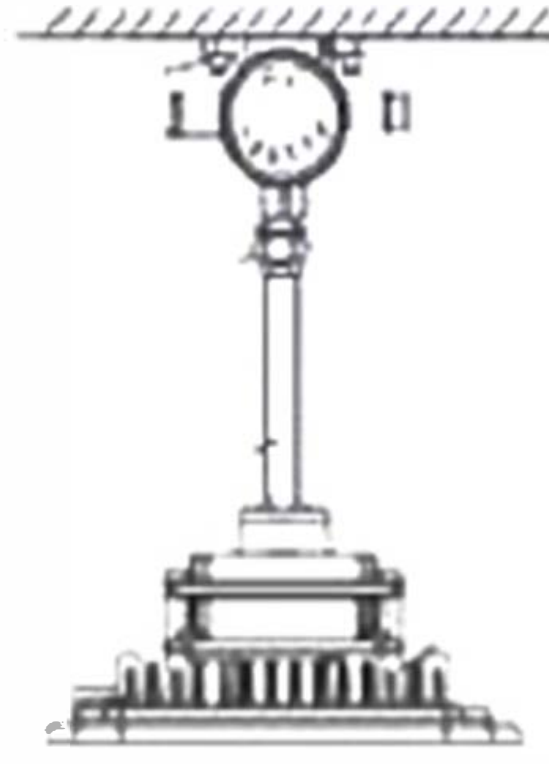

B. Drop Mounting

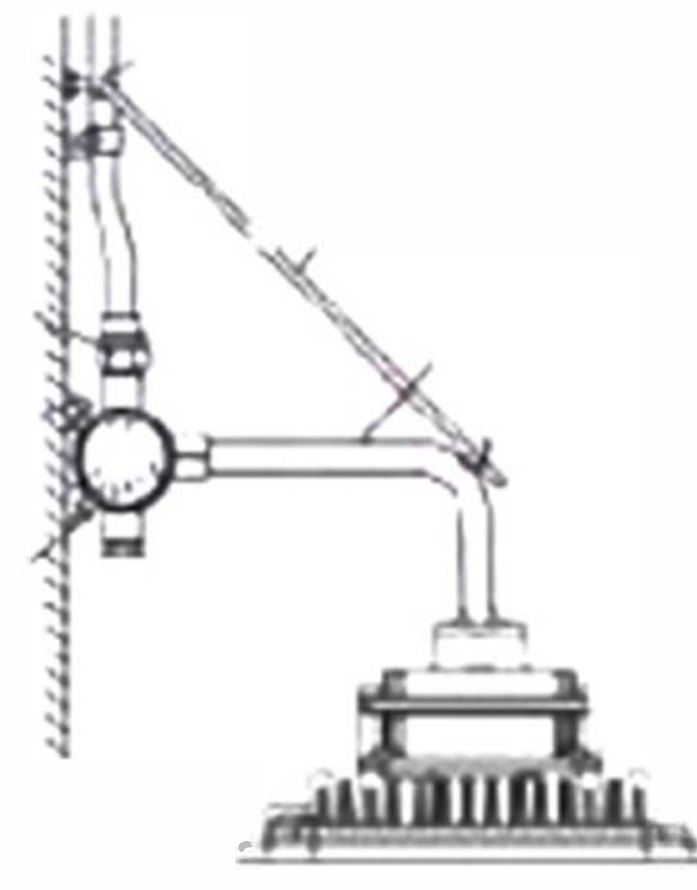

C. Wall Mount

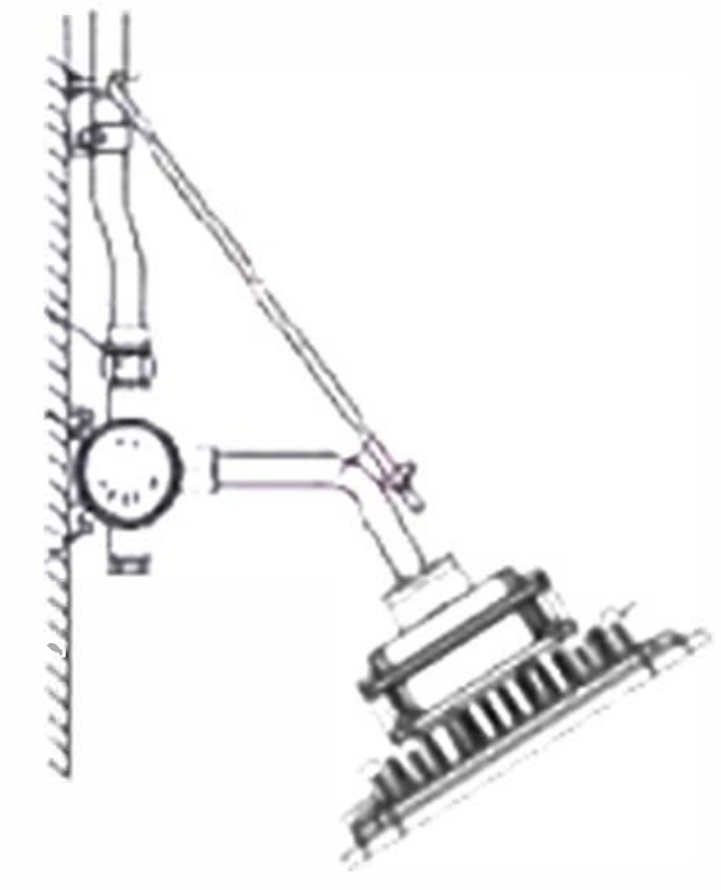

D. Wall Mount

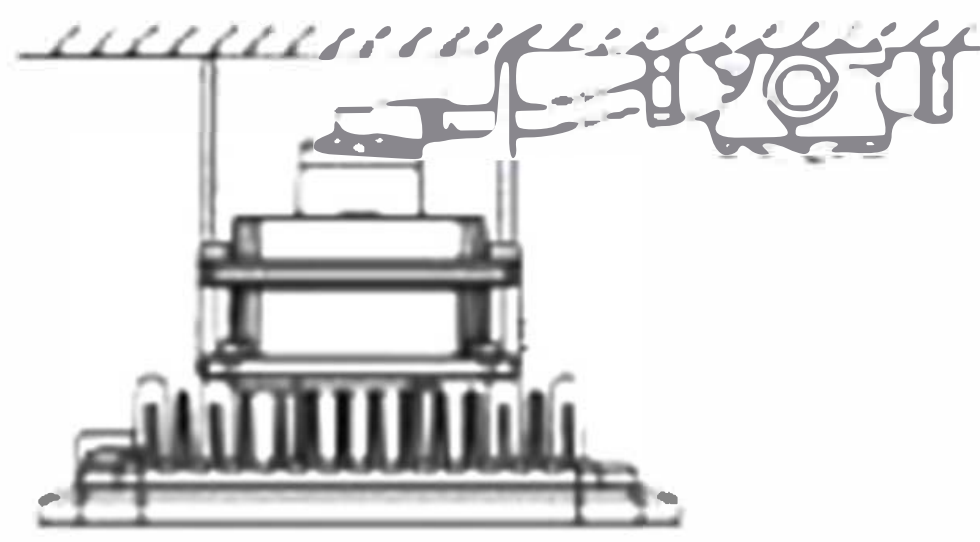

E. U-Bracket Mounting

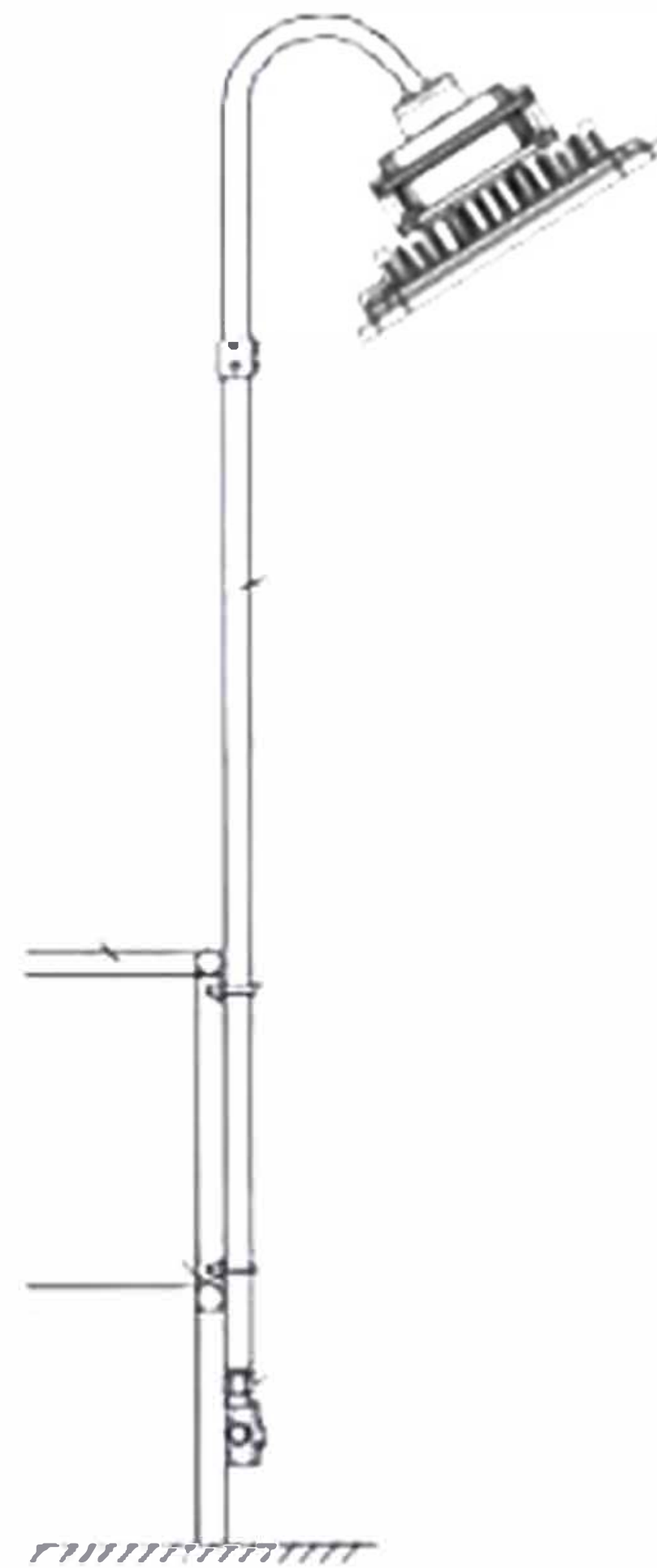
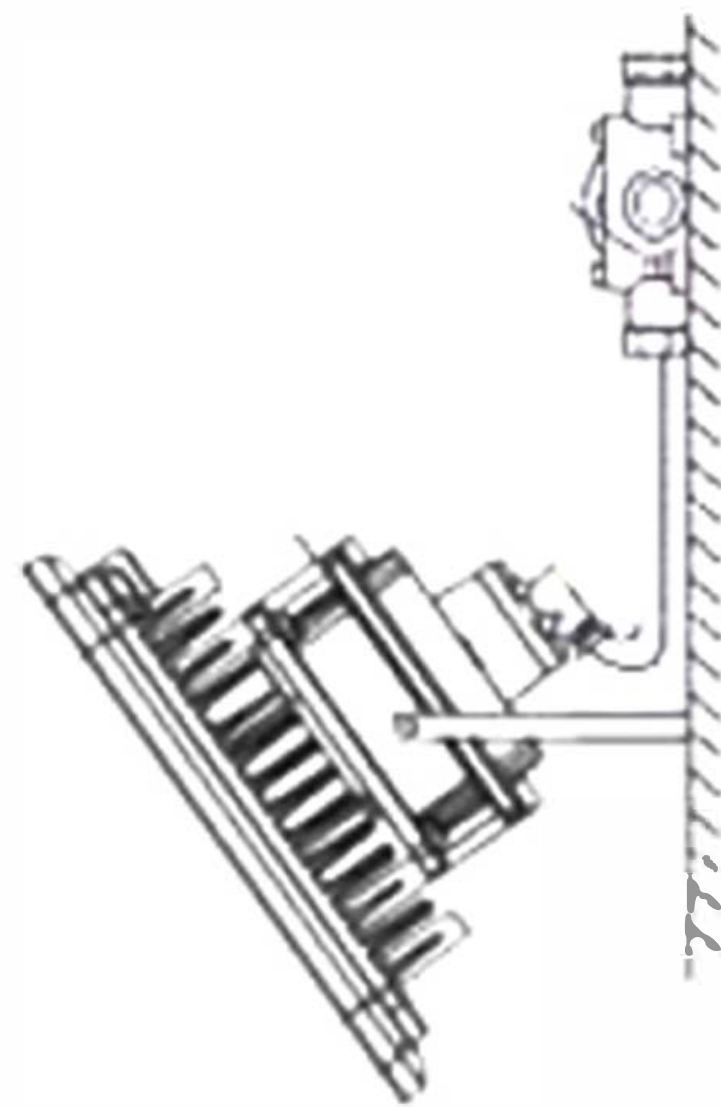

F. Pole Mount

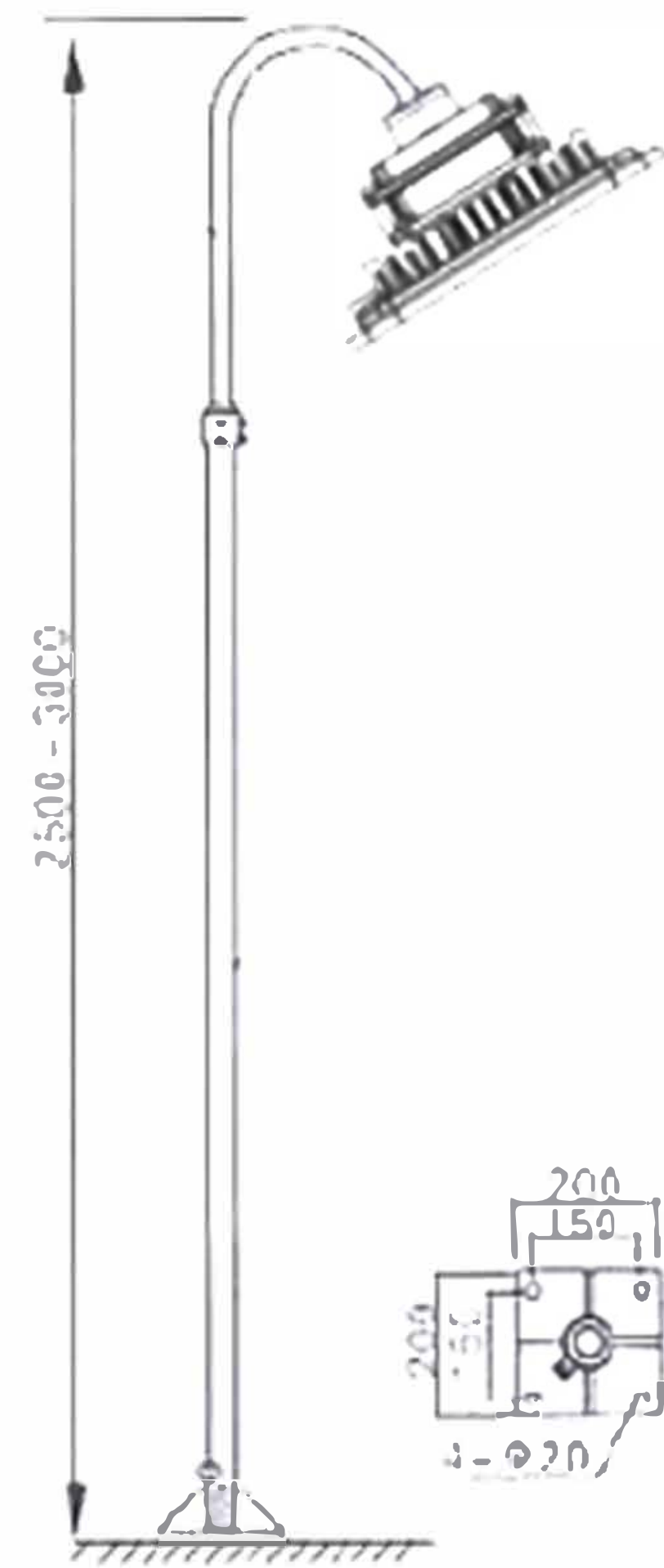

G. Pole Mount