

# INUI - 400W-CREE-XTE Specification

## Product Picture

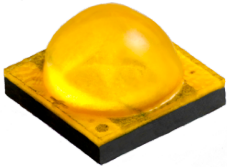

Cree® XLamp® XT-E LEDs



## Main Parameters

### Features:

1. Product Name: LED High Bay Light CREE XBD Series 400W.
2. Adopt Super Brightness USA Original CREE XTE LED Lighting Source, encapsulation by ourselves, Long lifespan, Energy saving, Environment friendly, High efficiency, No strobe, No ghosting, No UV, IR.
3. LED high bay light integrate LED lighting source and the cover of the light, the advantages are no needing extra cover, the volume is small and the weight of the body is light. Which make the led light perfect.
4. The Lighting source of the led high bay is using super bright big size LED chip, It' s single led chip with top quality which lumen is up to 120lm/W, Using high efficiency PC lens and sand blast oxidation light cover which can solve the problems such as light loss and colour shading. It can assure the uniformity of flux and colour.
5. Using high efficiency thermal conductivity silicon, it's assured the heat sink of the light, the temperature of the junction is not pass 65°C, which is effective controlled the light degradation, the lifespan for the led light is over 50000 hours.
6. High efficiency intelligence Driver and very professional design, which makes the surface temperature of the light body less than 60°C. The life span for the driver is over 50000 hours.
7. The range for the input voltage is wide. Which make the led high bay are available for the global. Unique protection circuit and exact constant current system assure the abilities such as anti-interference and stability of the light.
8. Available for solar DC10V-28V to realize the secondary energy saving system.

### Application:

LED High Bay Light is available for factory、 storage room、 public places、 lobby、 highway toll station、 exhibition building、 domestic block、 gymnasium、 gas station、 show room、 shop、 super market、 cool storage、 meeting room and other lighting places.

## Main Technology Index:

Model No.	400W-CREE-XTE
Equivalent	1000-1500W High Pressure Sodium Lamp
CREE LED QTY	CREE XTE 135 PCS
LED Luminous Efficiency	247 lm (700mA /3.0V CREE XTE-R5)
Lamp Total Power	400W
Power Efficiency	>94%
Lamp Rated Luminous Flux (LED)	>43200 lm ( 700mA /3.0V CREE XTE-R5 )
Lamp Rated Luminous Efficiency	> 118 lm/W
Colour Rendering Index (CRI)	Ra>75 (upgradeable to Ra90)
Colour Temperature	Cool white: 5500-7000K Pure white: 4500-5000K Warm white: 2600-3500K
Beam Angle	45°
Light Distribution Curve (Beam Pattern)	Symmetric expression/Circular glare
Input Voltage	AC90-305V / MEANWELL Driver UL/CB/CE
Frequency Range	47-63Hz
Power Factor (PF)	0.98-0.99
Total Harmonic Distortion (THD)	< 15%
Storage Temperature	-40°C--+80°C
Working Environment	-40°C--+50°C ; 10%-95%RH
Junction Temperature (Tj)	60°C ± 10%(ta=25°C)
Light Body and Lampshade Material	Aluminium Alloy and ASA / PC
Working Lifetime	> 50,000hrs
IP Rating	IP65
Product Net Weight	13.7 kg
Product Gross Weight	15.6 kg
Product Size (cm)	∅ 343 * H435mm
Product body Package Size (cm)	33*33*50CM (1PC)
Lamp Shade Package Size (cm)	47.7*47.7*47.8CM /15KG (20PC)

# Product Size

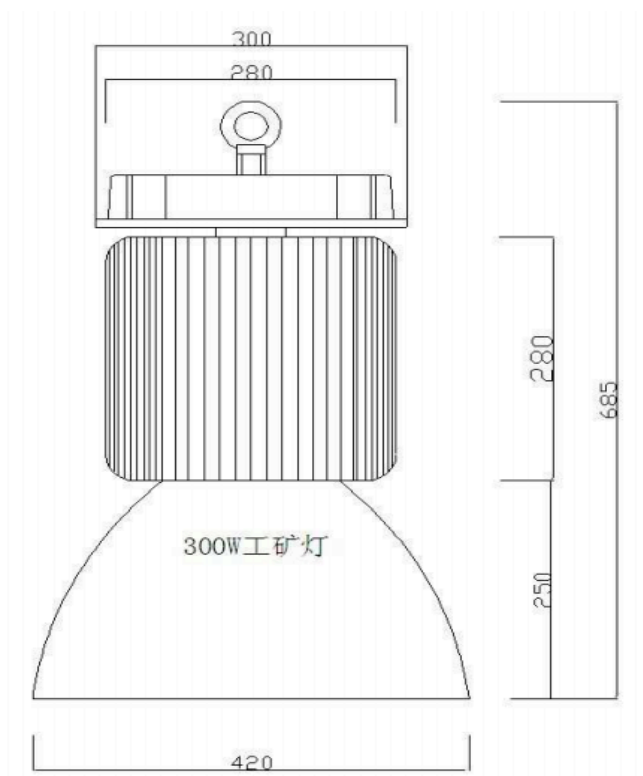

# Lighting Distribution Curve

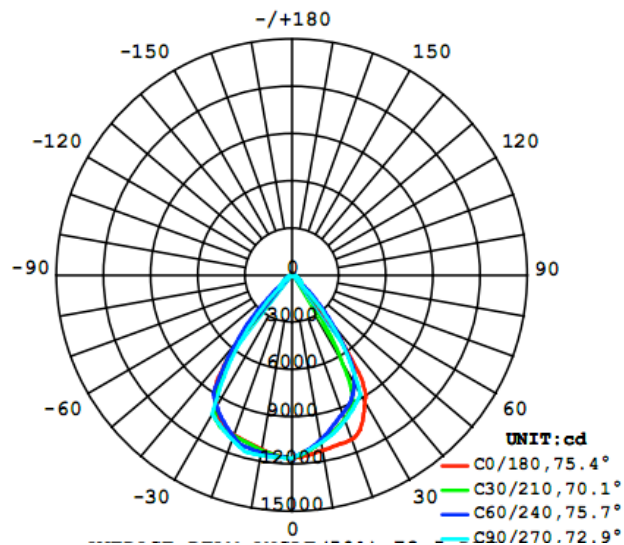

# Installation Instructions

1. When open the package, please check whether the inside is including product, accessory, label, and certificate quality. And please assure that the light is perfect without any damage.
2. The wires of led high bay light is three-core, the standard size of the wire is  $3 \times 1\text{mm}^2$  or  $3 \times 1.5\text{mm}^2$  and the outer diameter is  $\Phi 7 \sim 12\text{mm}$ , brown wire is live line, blue wire is null line, yellow & green is ground line.
3. LED high bay light will work when the voltage up to rated voltage, so please be sure the voltage within the requested range, or it will damage the light which can't be repaired.
4. When the electrical continuity is connected, the lead wire should be in electric insulating
- 5.

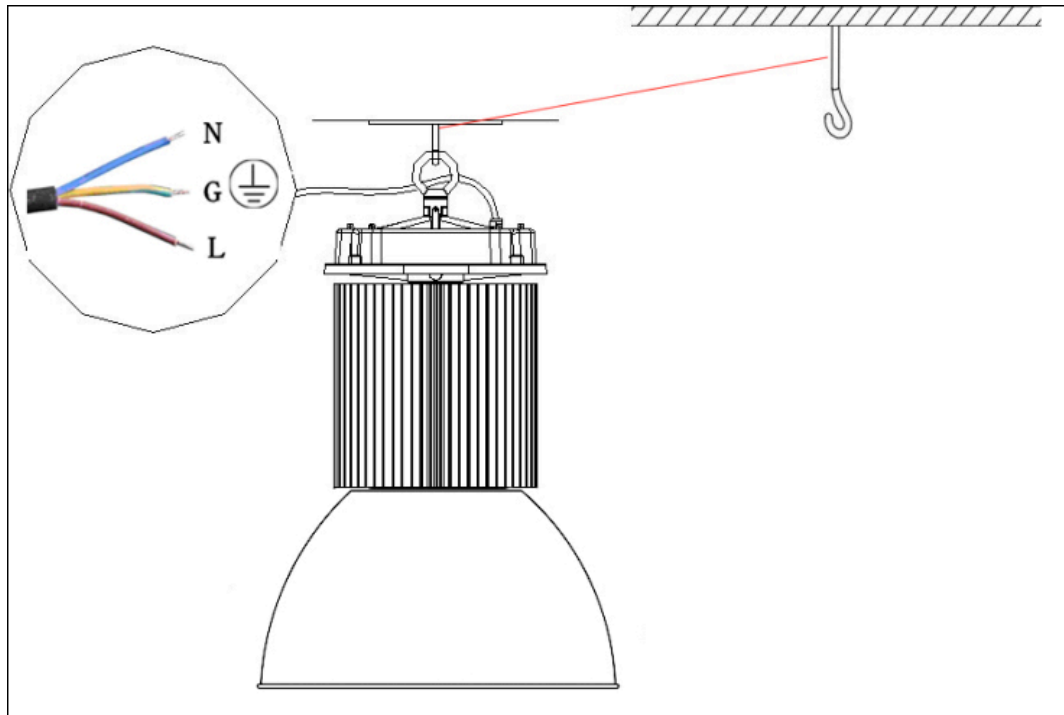

## Attention



1. In order to make sure the light can work safety and stability, the ground line should be connected the earth.
2. When connecting the wires please turn off the power, and check whether the wires are connected correctly. Never connect the wires in opposite way, or the power should not be turned on.
3. Please keeping the trip bolt being fastening and reliable, in case of the light fall down of looseness.
4. Please keep the hook which has screw thread into the e-box tapping hole, in sure the hook is tightened, use M4 screw hook to fasten the coin slot screw. To prevent the looseness of the screws.
5. When finishing connect the wires, please use the insulation gummed tape to cover the wires fully.

More Details Please Contact With Us

**Guarantee for the quality and sales service:**

LED high bay light is a new style green energy saving led lighting, we offer 5 years warranty.

Any question happens when opening the package, please feel free to contact with our sales service department, we will ask our professional engineer to help you solve your question asap.

**LEDecolite will not offer any guarantee in the following situation:**

- ◆ The damage due to incorrect installation and operation or using the light not in the regulated working ambient.
- ◆ The damage due to abusing or misusing, without well protection or happens in transition.
- ◆ The damage due to customers open the lamp without authored or replacement the INUI LED confirmed accessories by themselves.
- ◆ The Damage due to personal or nature disaster and other things can't be predicted.