

One hundred percent authentic manufacturer, more than 10 years experience in production of led light
 With excelsior attitude, we aim to offer perfect product, as we believe vitality of a enterprise is depends on quality of product
 5 years warranty, release innovative, reliable and high-performance LED light regularly
 We care and take care of every inquiry, feedback and complaint of customers
 Customer is partner, we pursuit profit, value and development with partner together

Product Features

Streamline design classic aesthetics;
 Ultra-slim sleek design, stylish and classic;
 Reflector and heat sink integrated;
 Pure aluminum structure for heat dissipation, professional optical design;
 Luminous efficiency is increased by 50%.



**MODEL NO: LEDFLD-30
(30W)**

LED QTY: 30 PCS(OSRAM 3030)/30 PCS(PHILIPS 3030)
 Packing Type: 20 unit(s)/ctn
 Inner Packing Dimension: 26x19.5x4.8cm/1PCS
 Packing Dimension: 53.5X40.5X26cmcm
 NW: ≈1.4kg
 GW: ≈1.8kg 1 unit(s)/ctn
 GW: ≈38kg 20 unit(s)/ctn

PHILIPS / OSRAM / NICHIA 3030: 30W

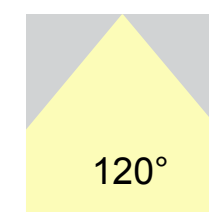

LED By:   

Powered By: 

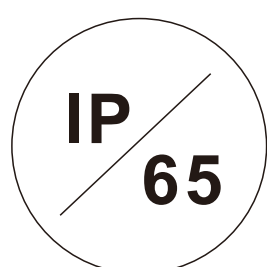

Protection grade reaches Ip65

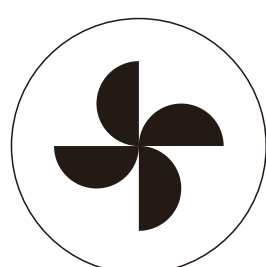

Anti-Level-17 hurricane



Adjustable 270° Angl



Working Temperature: -40-50°C

Working Humidity: 10%~95%RH

Best Working Temperature: -20 C ~+30°C

Storage Temperature: -40 C ~+80 C

01

REFLECTOR AND HEAT SINK INTEGRATED

Large size aluminum PCB fit aluminum die cast housing, reflector and heat sink integrated

(Note: only as illustrated below, with a series of contrast principle is the same)



02

DESIGN INNOVATION, EFFECTIVE PROTECTION

Innovative G-buckle technology, prevent glass off, free of screw fixing, elegant appearance, easy for assembling

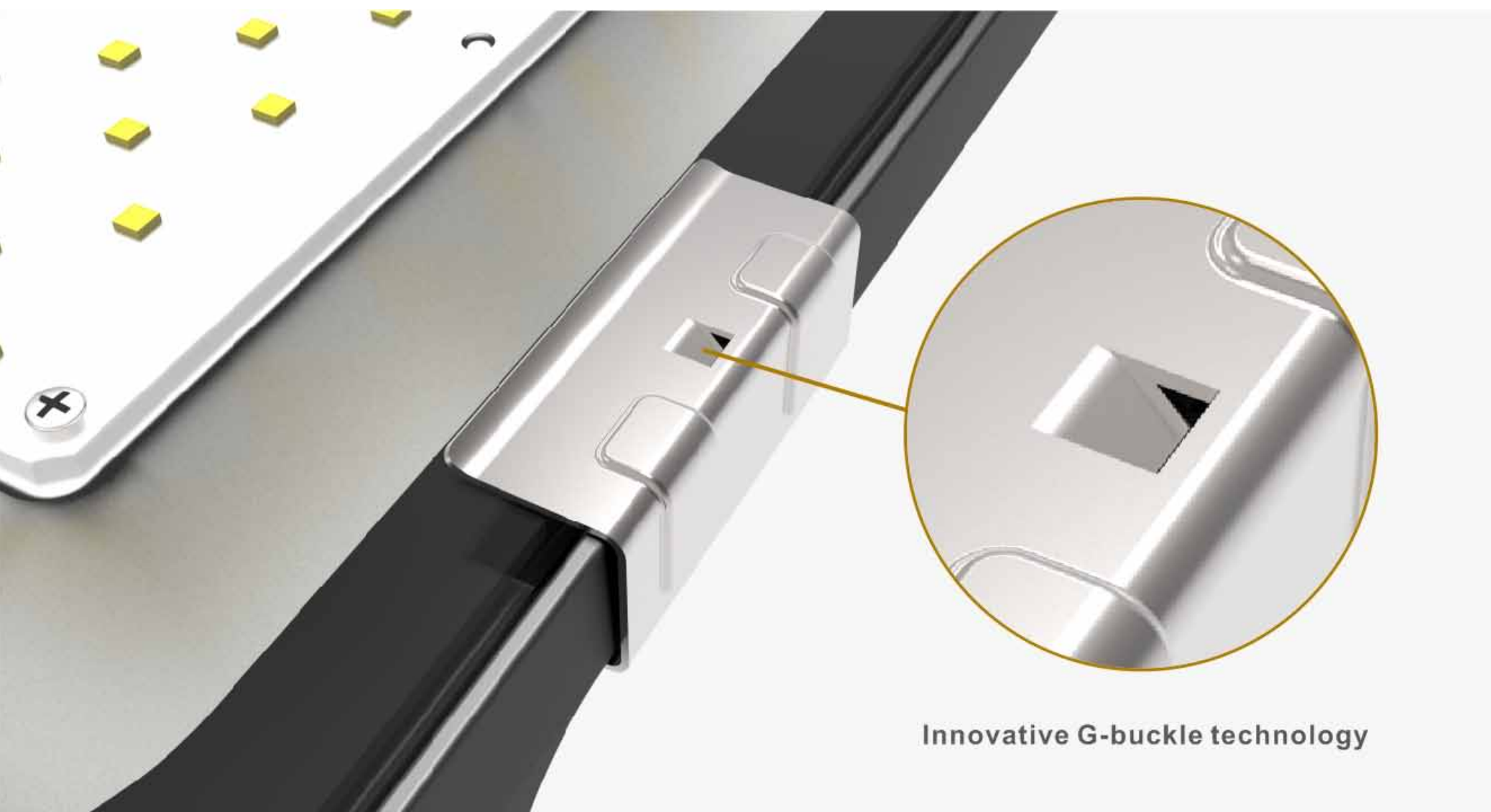

Innovative G-buckle technology

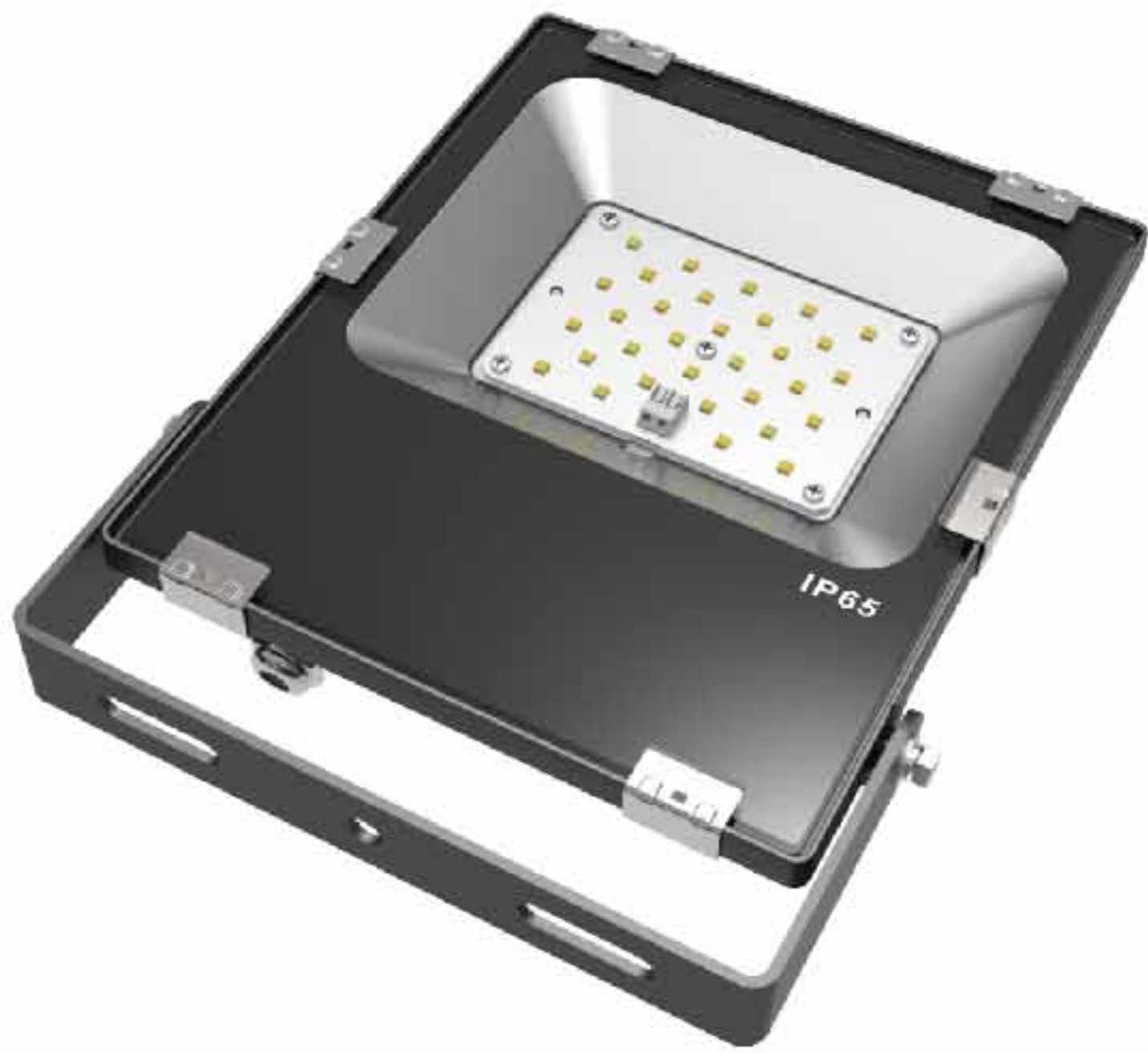

03 PROFESSIONAL LIGHT DISTRIBUTION AND LIGHT EFFICIENCY INCREASED BY 50%

The same condition, TG3A project-light lamp series by professional optical design, compared to traditional cast light lighting effect can be improved 50%

(Note: only as illustrated below, with a series of contrast principle is the same)

Effect of the light contrast figure

Unit : lm/W

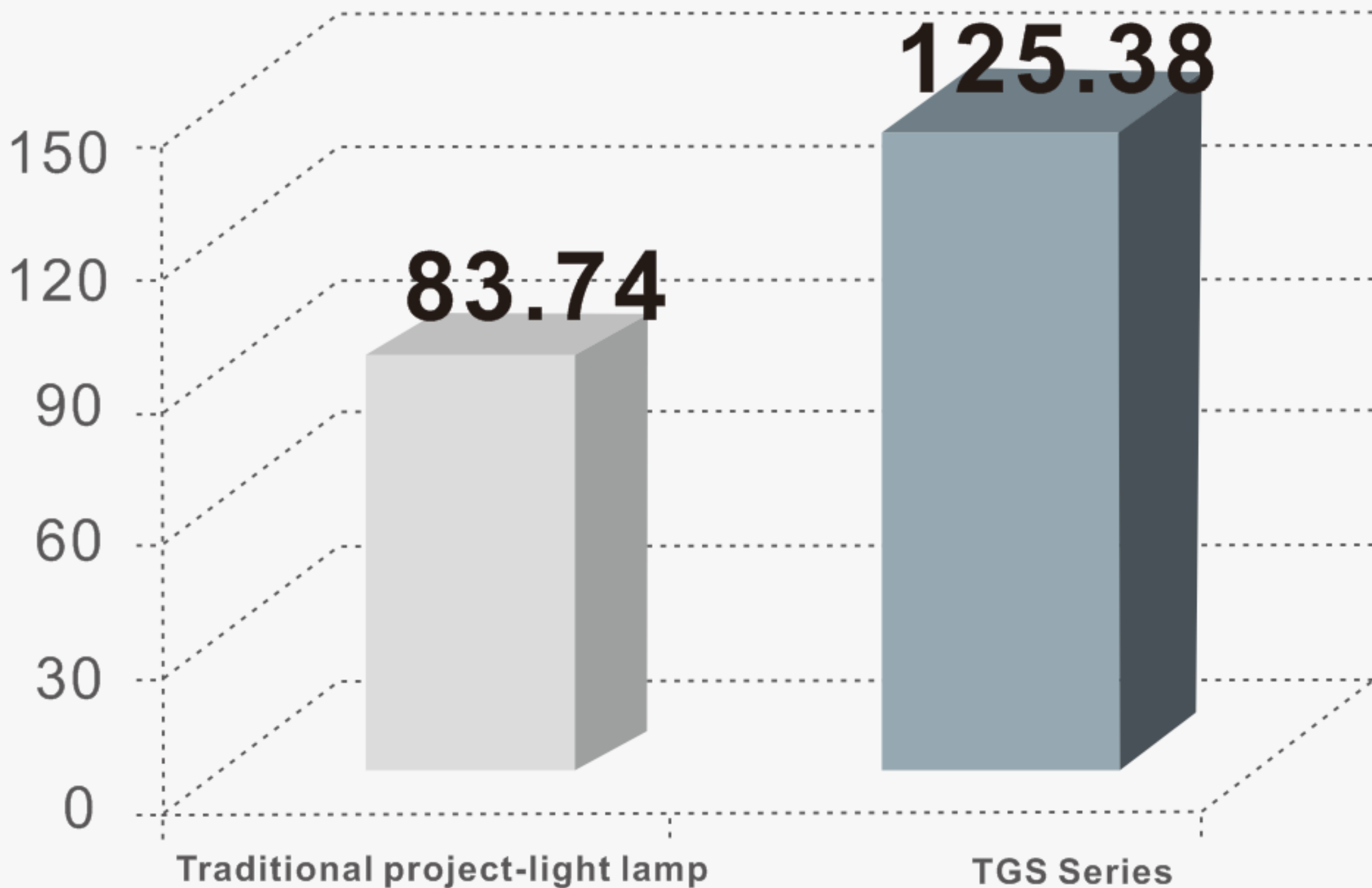

APPLICATION PLACES

Widely used in shopping mall, exhibition hall, parking lot, playground, gymnasium, billboards, park, sculpture, national green lighting project, building facade and public corridor, stair corridor and other indoor and outdoor lighting.

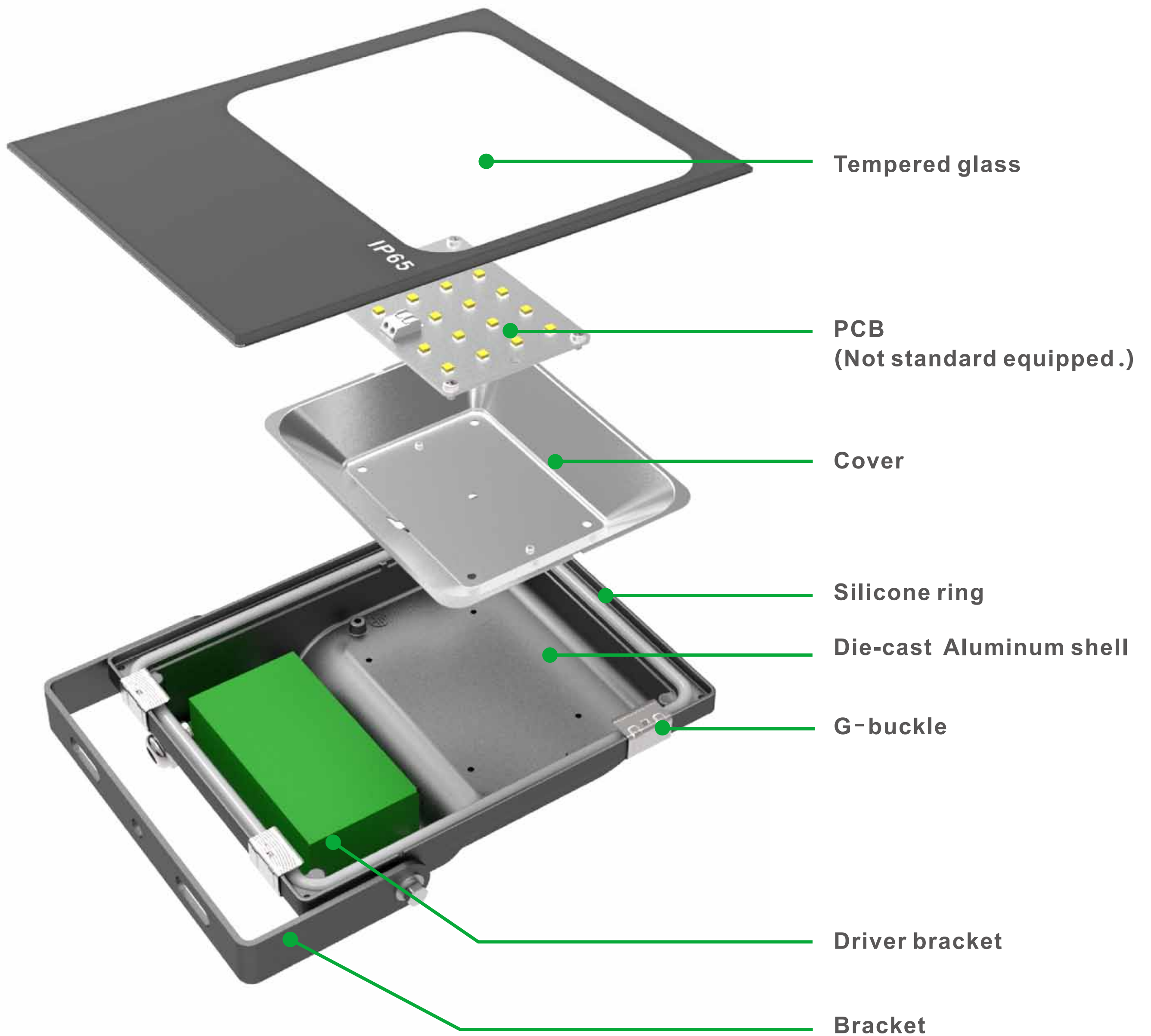

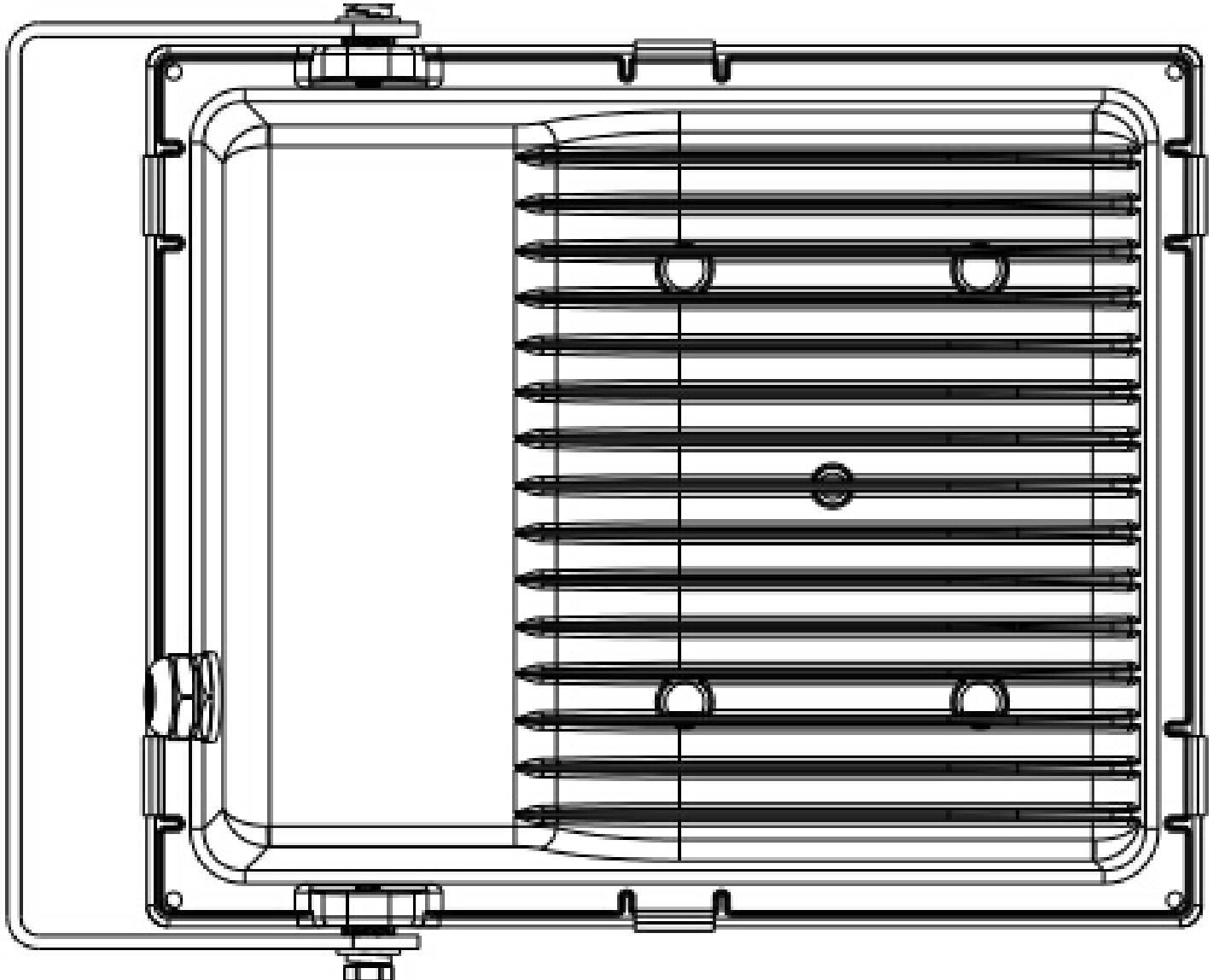
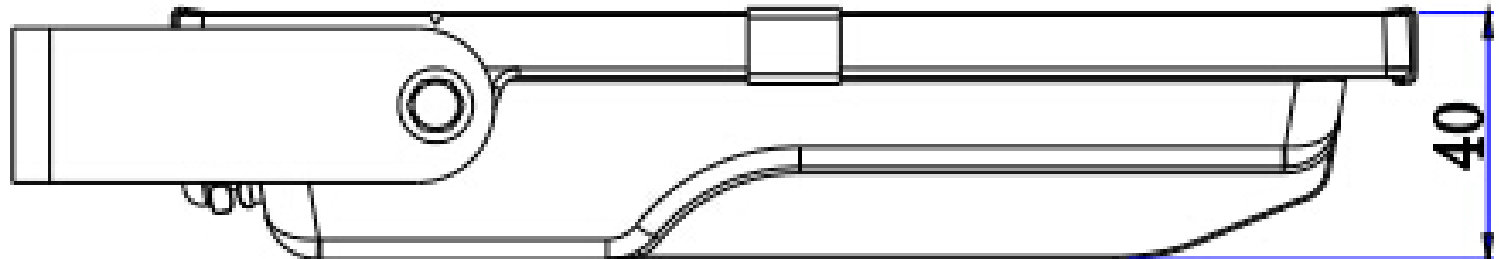
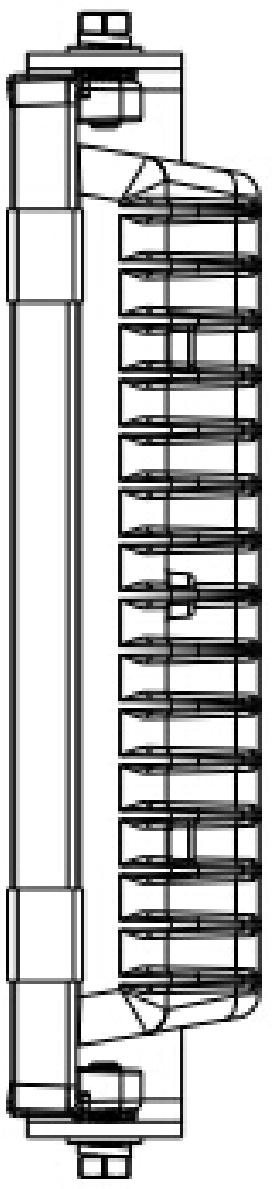
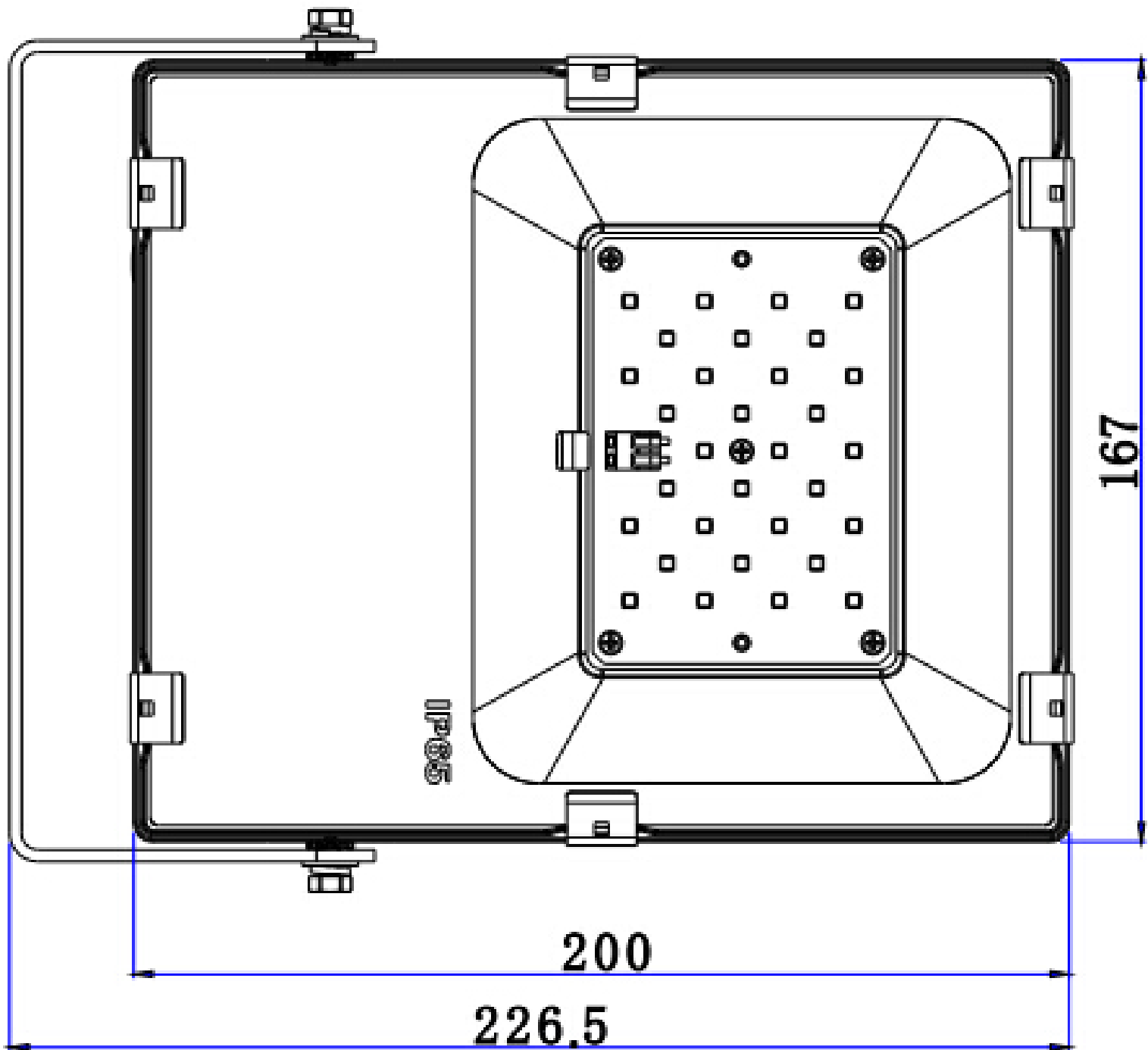
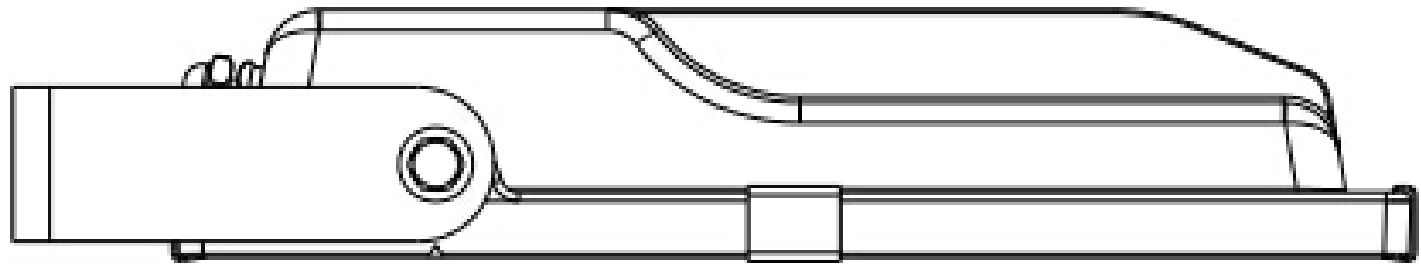
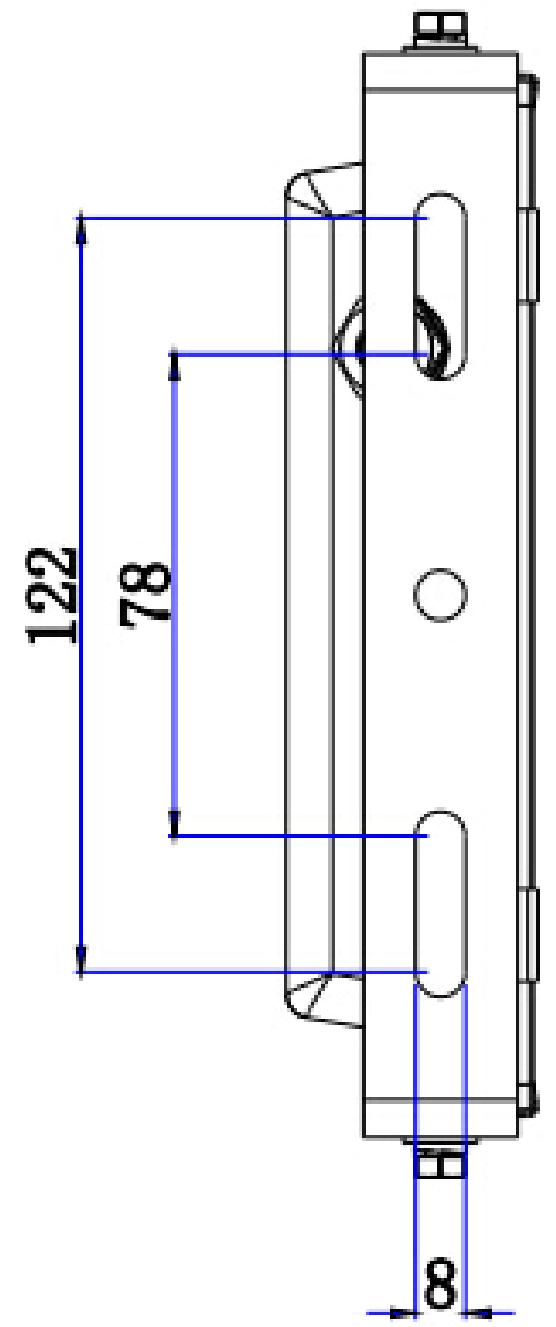

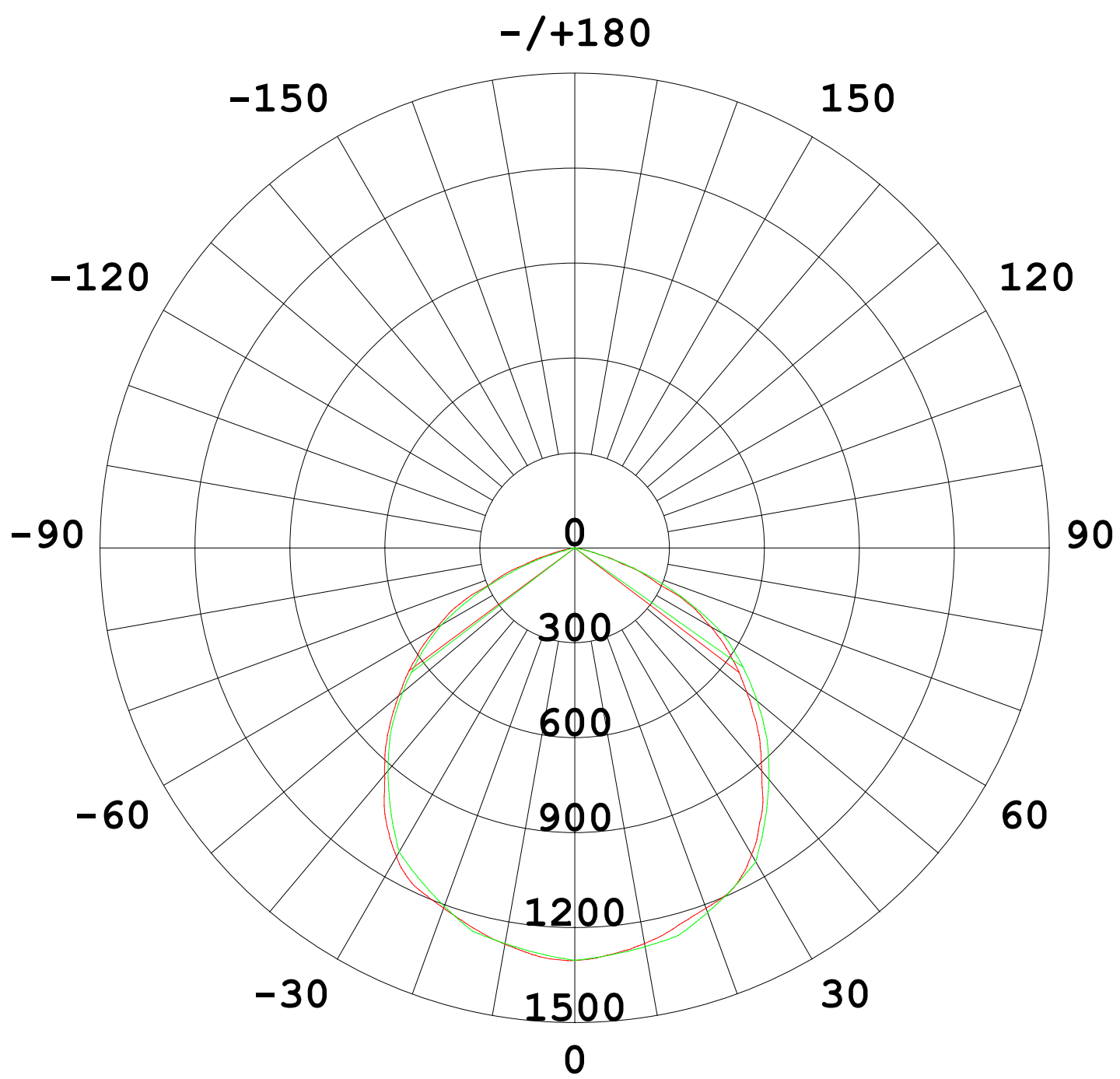

| | | |
|----------------|------------------------------------|----------------------|
| 9.843ft 3m | 4.562, 13.46fc 49.10, 144.91x | 26.3ft 801.74cm |
| 19.69ft 6m | 1.140, 3.364fc 12.28, 36.211x | 52.61ft 1603.49cm |
| 29.53ft 9m | 0.5069, 1.495fc 5.456, 16.101x | 78.91ft 2405.23cm |
| 39.37ft 12m | 0.2851, 0.8411fc 3.069, 9.0541x | 105.2ft 3206.98cm |
| 49.21ft 15m | 0.1825, 0.5383fc 1.964, 5.7941x | 131.5ft 4008.72cm |
| Height | Eavg, Emax | Diameter |

LX-TGS30

LED CHIP MODEL

POWER

Light source



PHILIPS
LUMILEDS

>100lm/ W
30W



X 30



OSRAM
Opto Semiconductors

>105lm/ W
30W



X 30



NICHIA

>110lm/ W
30W



X 30