

Product Features

- Built-in mean well HLG LED driver
- Original LUXEON 5050 , High efficiency, High stability
- Dimmable (PWM、Dali、0/1-10V) custom made,
- Optical switch, dimming, computer / mobile phone / tablet control, Internet control, piecewise output, external sensors (external arbitrary type sensor, sense of sense of light, sound, car, etc., a sensor to control a plurality of lamp), can assist the product network group system, access the Internet of things



MODEL NO: INUI-HBLB240
(240W)

LUXEON QTY: 240W 48pcs

Packing Type: 1 unit(s)/ctn
Packing Dimension: 44*44*24cm
NW:≈9.3kg
GW: ≈10.5kg 1 unit(s)/ctn

LUXEON : 240W



LED By: **LUXEON LUMILEDS**

Powered By: **MW MEAN WELL**

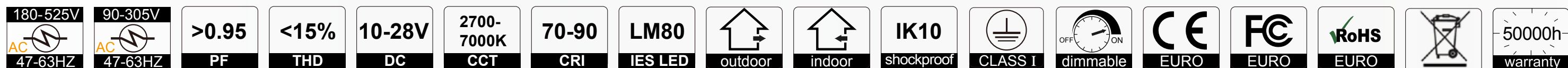

Working Temperature: -40~50°C

Working Humidity: 10%~95%RH

Best Working Temperature: -20 C ~ +30°C

Storage Temperature: -40 C ~ +80 C



- 5 YEAR WARRANTY
- LONG LIFE 50000HOURS
- IP65/67

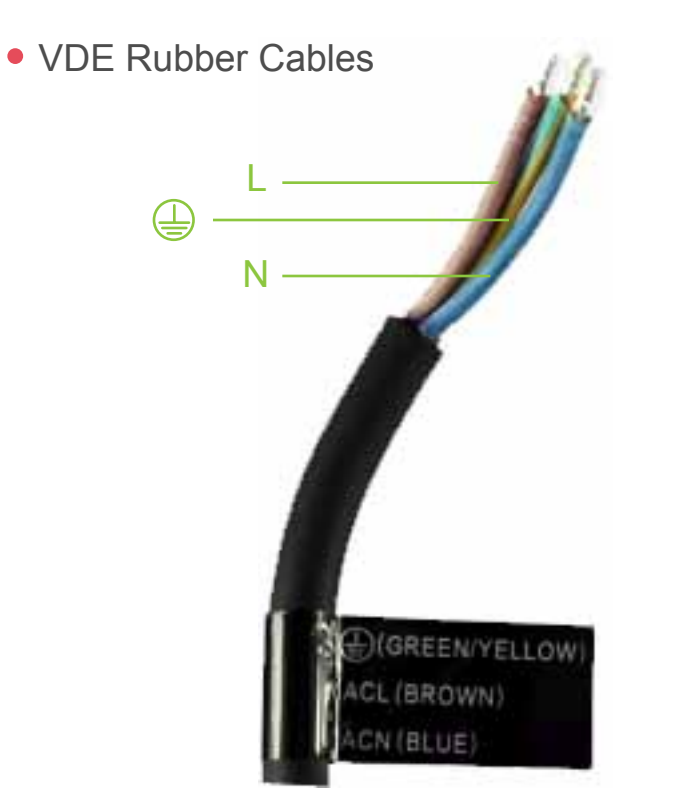

- Electrostatic spraying the surface, strong corrosion resistance



- Waterproof grade IP65.



- Thanks to the ingenious design, the lamps could be IP65 although there is no glues are applied. So the Ingress protection of lamps won't cease to be effective because of glue aging.

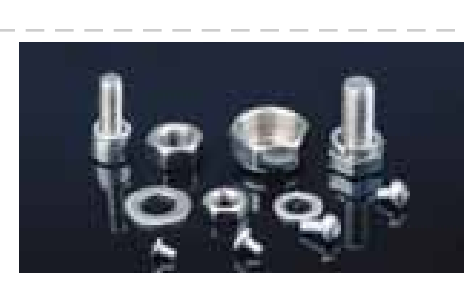

- Endurancing the corrosion of air, water, chemical acid, alkaline, salt and other materials, can be used in all kinds of harsh conditions for long term.



- 180° angle regulator, Adjustable mounting bracket



- The professional optical reflector, Optical glass lens, the light out rate of more than 95%

• DIVERGENT VERTICAL RADIATING RIB DESIGN, DUST FREE

Aluminum Alloy, Integrated Molding, Better Heat Dissipation.

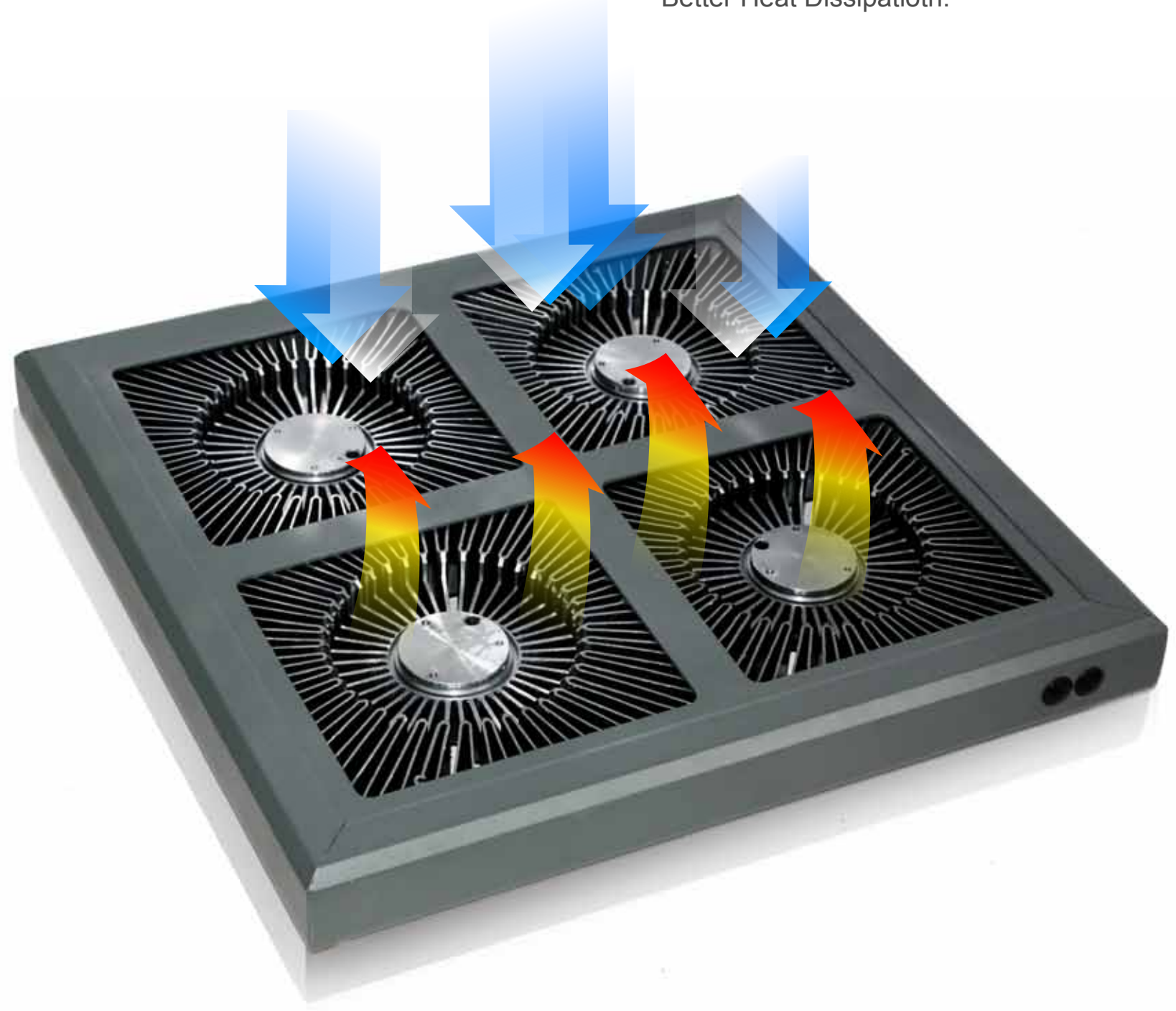

High efficiency heat radiation
Ventilated dissipation structure-which represents the Direction of development



Patent design
Fashionable and textured, Focused on the heatsink design, patented appearance, technical protection



- SURFACE ELECTROSTATIC SPRAYING, HIGH THERMAL CONDUCTIVITY, CORROSION RESISTANCE.

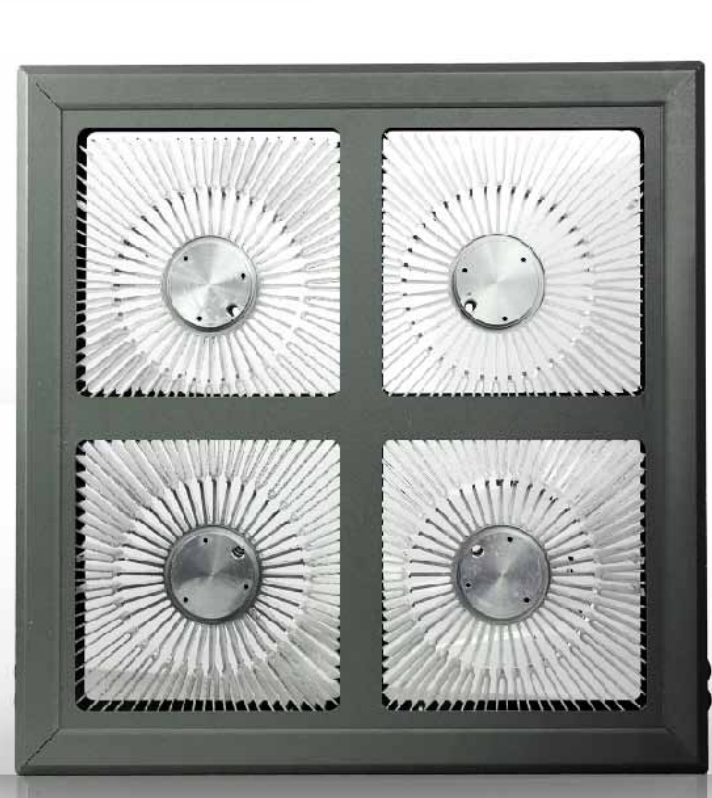

LEADING AND INNOVATION CORE TECHNOLOGY OF COPPER SUBSTRATE

Abstract

MHE301 is a low thermal impedance substrate solution for led Light, In term of both Material and structure design it specifically answers the need of heat dissipation for HB and ultra HB LEDs by draining heat with metallic MHE at thermal conductivity up to 401W/mk, MHE301 exhibits a thermal impedance of 0.005°-cm2/Watt at its best, Making it arguably the best commercially available solution for improving the led junction temperature

- a. Upper copper layer as traces and pads for soldering and connection;
- b. MHE, with 401W/mk thermal conductivity, provides thermal conduction for LED, transferring heat to metal base;
- c. metal base dissipate heat to heat sink or ambient.

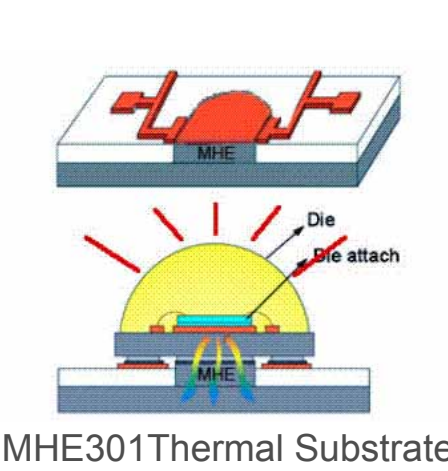

- LUXEON 5050 chips
Original LUXEON Chip
LM80 certified

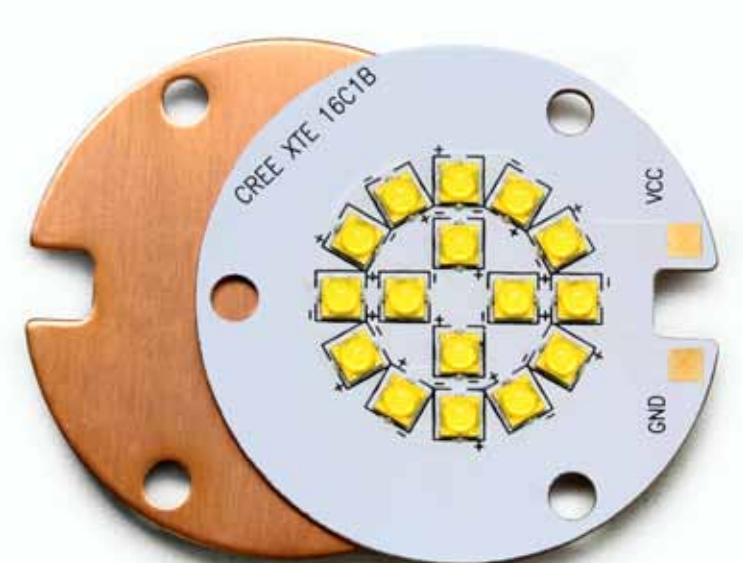

- Thermal Conductivity (Watt/ mk) : 401 W/mk
- Thermal (C) 0.005 C-cm2/Watt
- Glass Transition Temperature(C): 150-180 C
- Max. Operating Temperature(C): 130 C
- Max. Soldering Temperature(C): 300 C
- I/P-O/P: 3.75KVC



Custom-made hanger rod/ hanger by request only

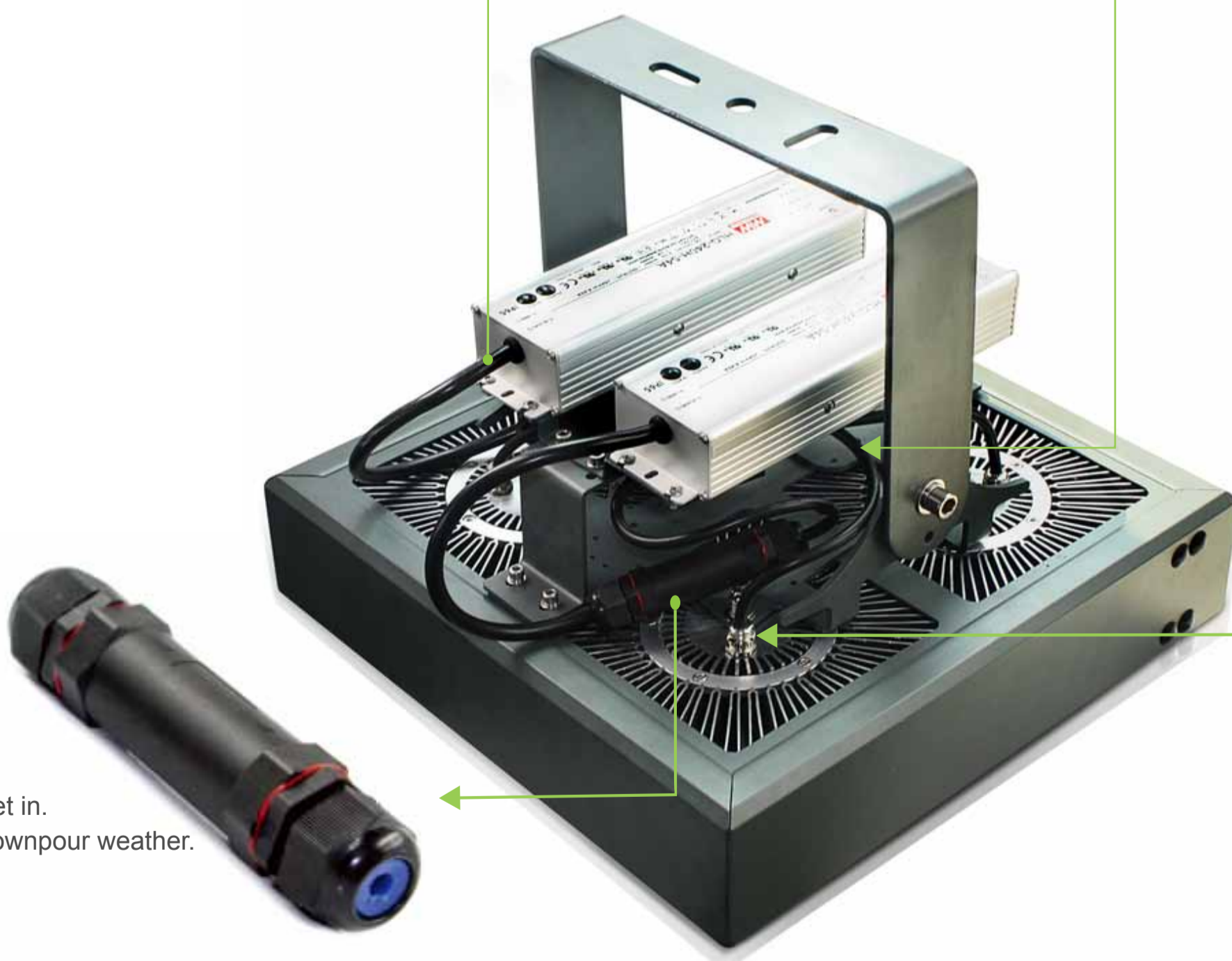
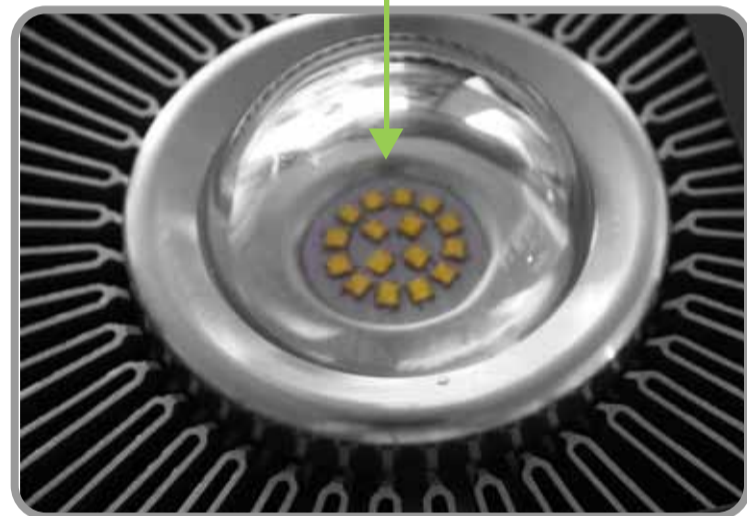

- Seal by silicone gel ring,
- IP grade is **IP68**.
- Totally prevent dust to get in.
- Prevent water even in downpour weather.

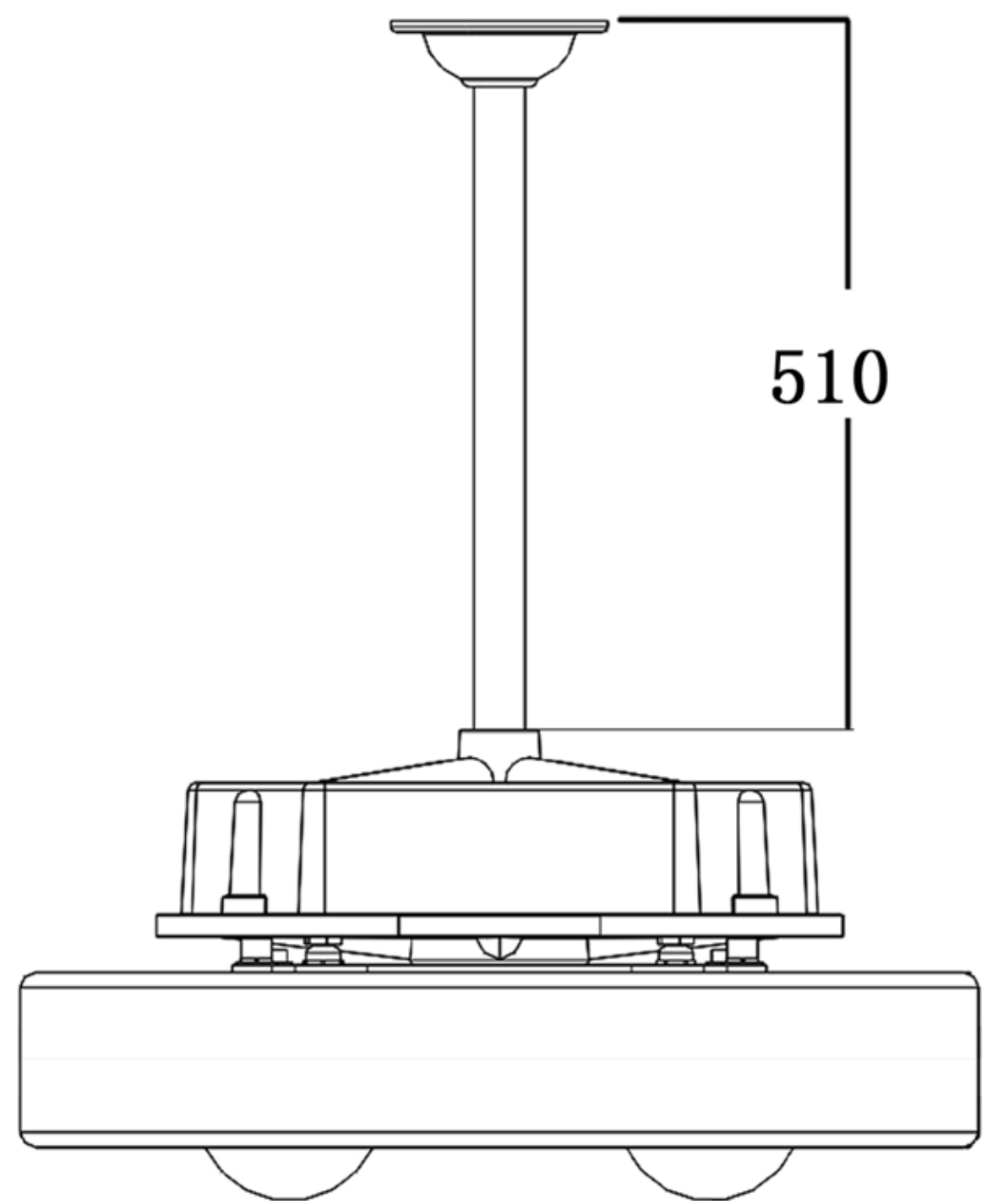
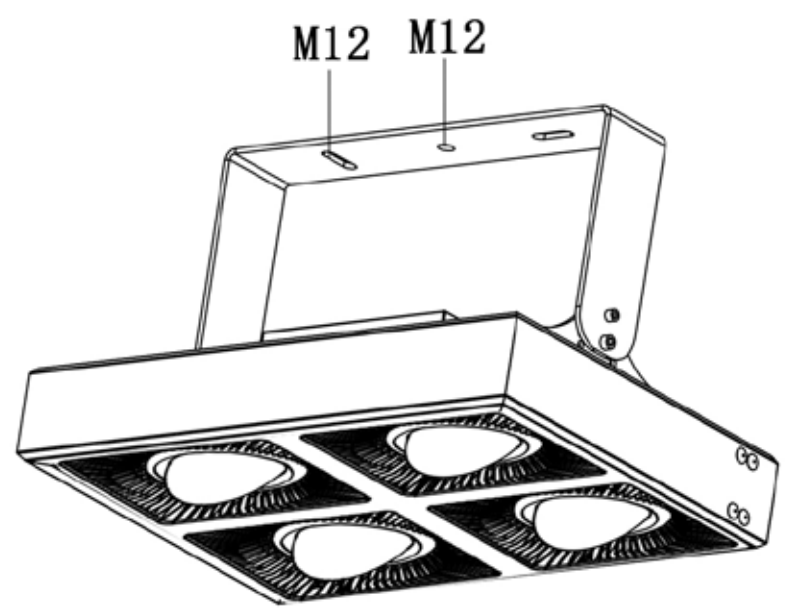
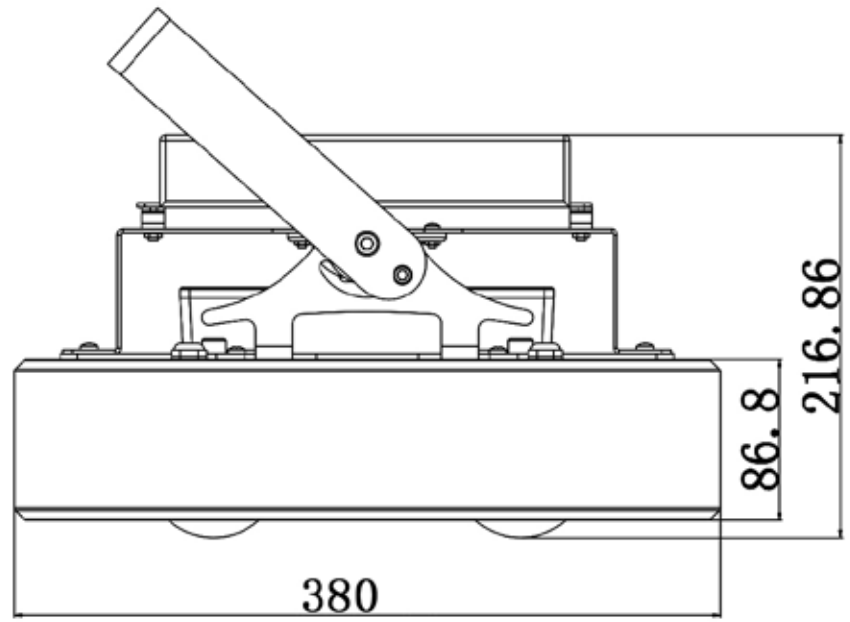
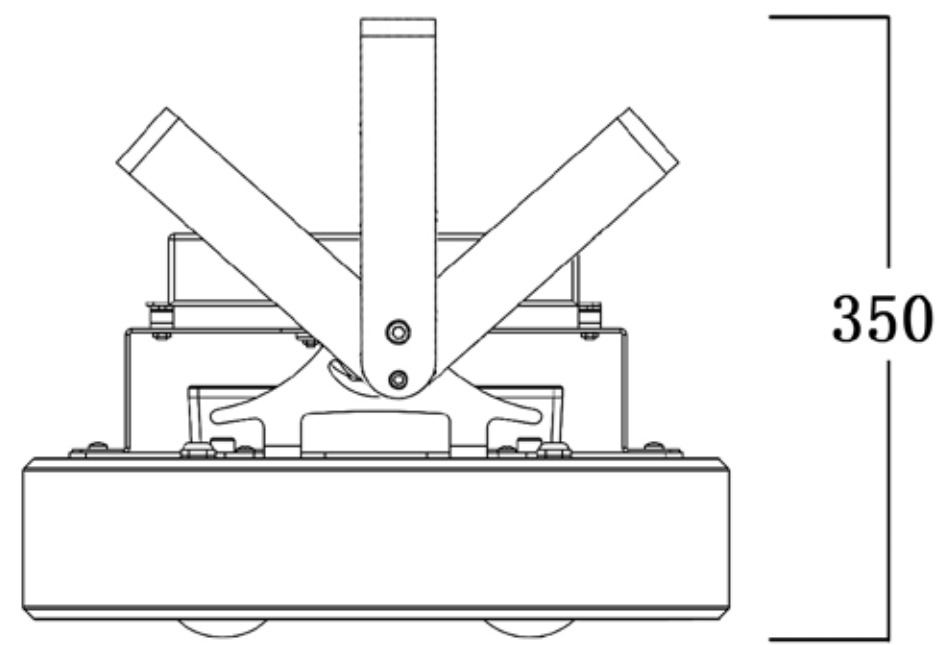
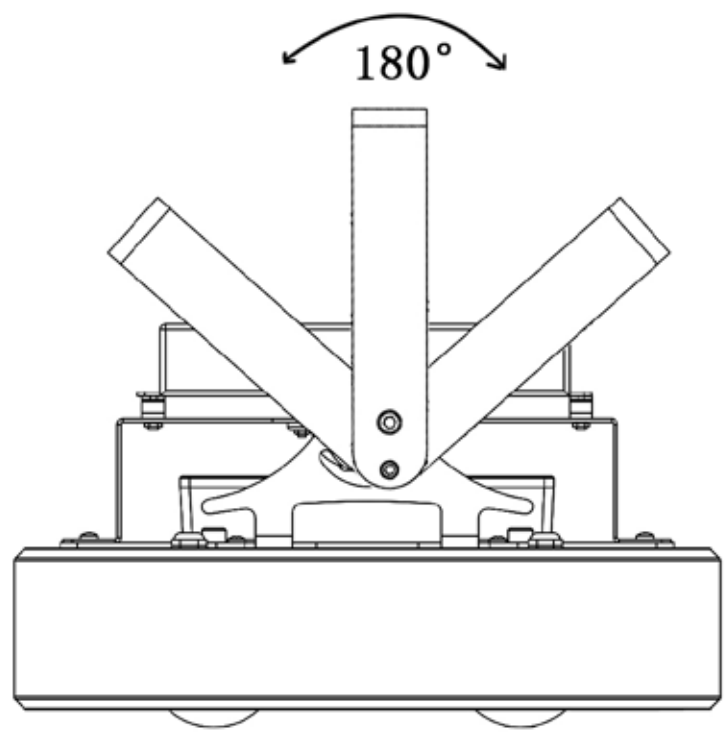

INUI- HBLB380

LED CHIP MODEL

POWER

Light source



LUXEON
LUMILEDS



>140lm/ W

240W
48pcs



X4

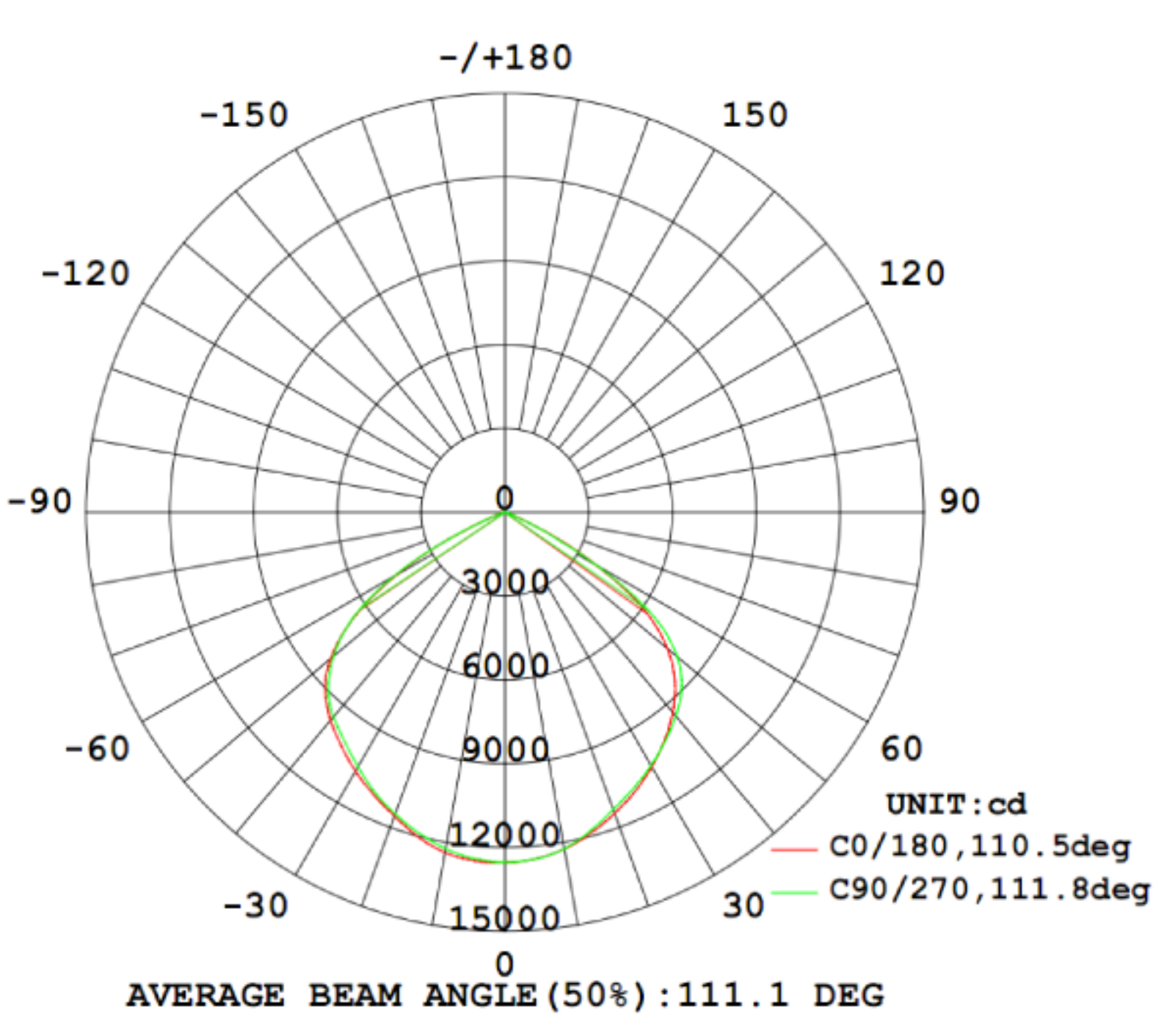

| Height | Eavg, Emax | Diameter |
|---------------|----------------------------------|----------------------|
| 3.281ft 1m | 355.9, 1165fc 3831, 12542lx | 9.601ft 292.64cm |
| 6.562ft 2m | 88.99, 291.3fc 957.8, 3135lx | 19.2ft 585.28cm |
| 9.843ft 3m | 39.55, 129.5fc 425.7, 1394lx | 28.8ft 877.92cm |
| 13.12ft 4m | 22.25, 72.82fc 239.5, 783.9lx | 38.4ft 1170.56cm |
| 16.4ft 5m | 14.24, 46.61fc 153.3, 501.7lx | 48.01ft 1463.20cm |

