

One hundred percent authentic manufacturer, more than 10 years experience in production of led light
 With excelsior attitude, we aim to offer perfect product, as we believe vitality of a enterprise is depends on quality of product
 5 years warranty, release innovative, reliable and high-performance LED light regularly
 We care and take care of every inquiry, feedback and complaint of customers
 Customer is partner, we pursuit profit, value and development with partner together

Product Features

Streamline design classic aesthetics;
 Ultra-slim sleek design, stylish and classic;
 Reflector and heat sink integrated;
 Pure aluminum structure for heat dissipation, professional optical design;
 Luminous efficiency is increased by 50%.



**MODEL NO: LEDFLD-100
 (100W)**

LED QTY: 100 PCS(OSRAM 3030)/100 PCS(PHILIPS 3030)
 Packing Type: 1 unit(s)/ctn
 Packing Dimension: 48*39*13.5cm
 NW: ≈5.1kg
 GW: ≈6.1kg 1 unit(s)/ctn

PHILIPS / OSRAM / NICHIA 3030: 100W

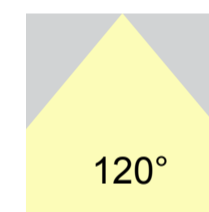

LED By:   

Powered By: 



Protection grade reaches Ip65

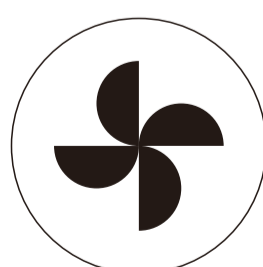

Anti-Level-17 hurricane

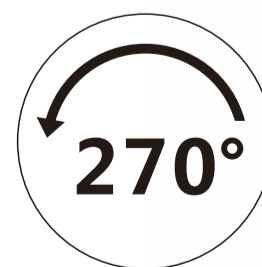

Adjustable 270° Angle



Working Temperature: -40-50°C

Working Humidity: 10%~95%RH

Best Working Temperature: -20 C ~+30°C

Storage Temperature: -40 C ~+80 C

01

REFLECTOR AND HEAT SINK INTEGRATED

Large size aluminum PCB fit aluminum die cast housing, reflector and heat sink integrated

(Note: only as illustrated below, with a series of contrast principle is the same)

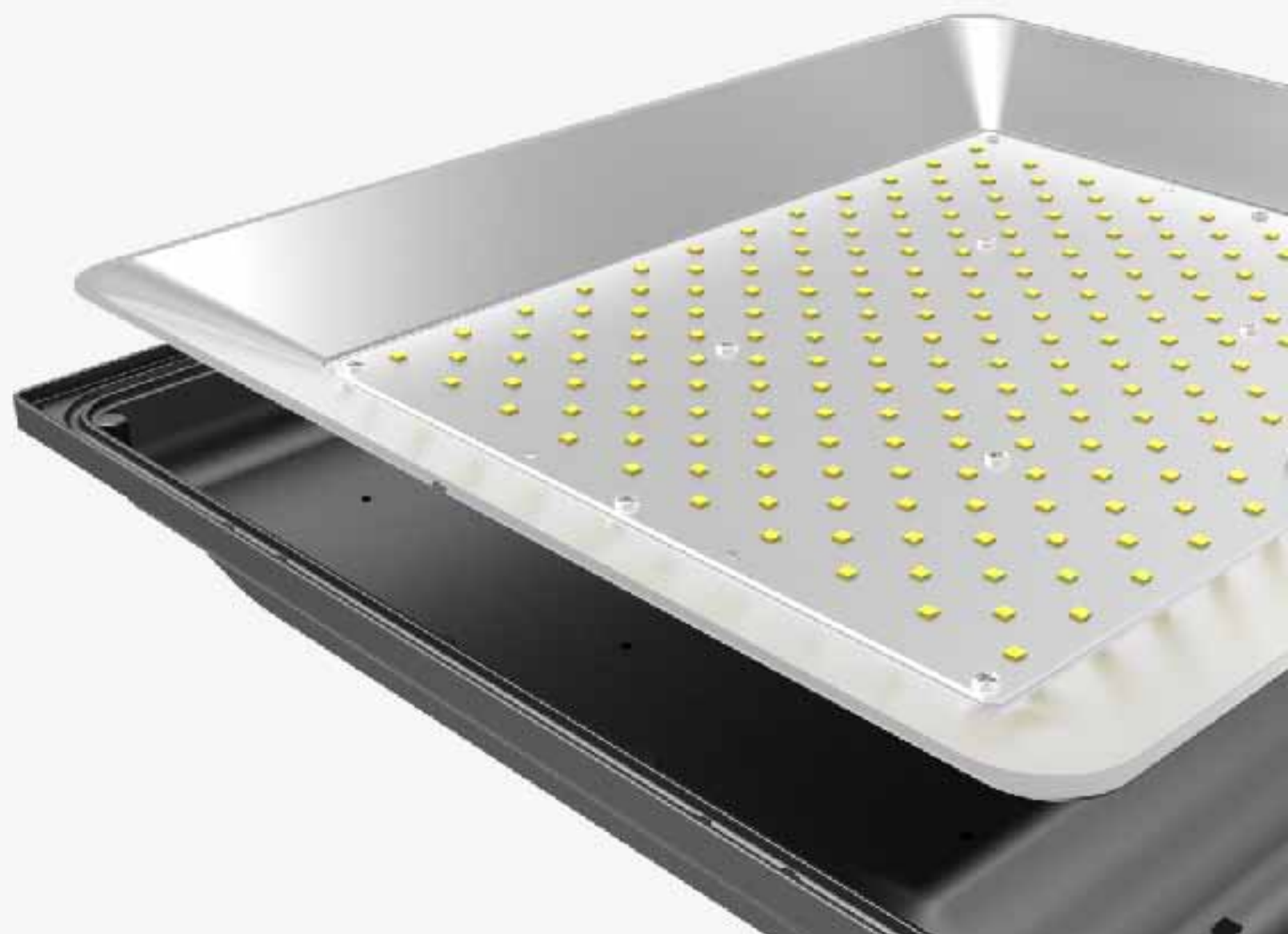

02

DESIGN INNOVATION, EFFECTIVE PROTECTION

Innovative G-buckle technology, prevent glass off, free of screw fixing, elegant appearance, easy for assembling

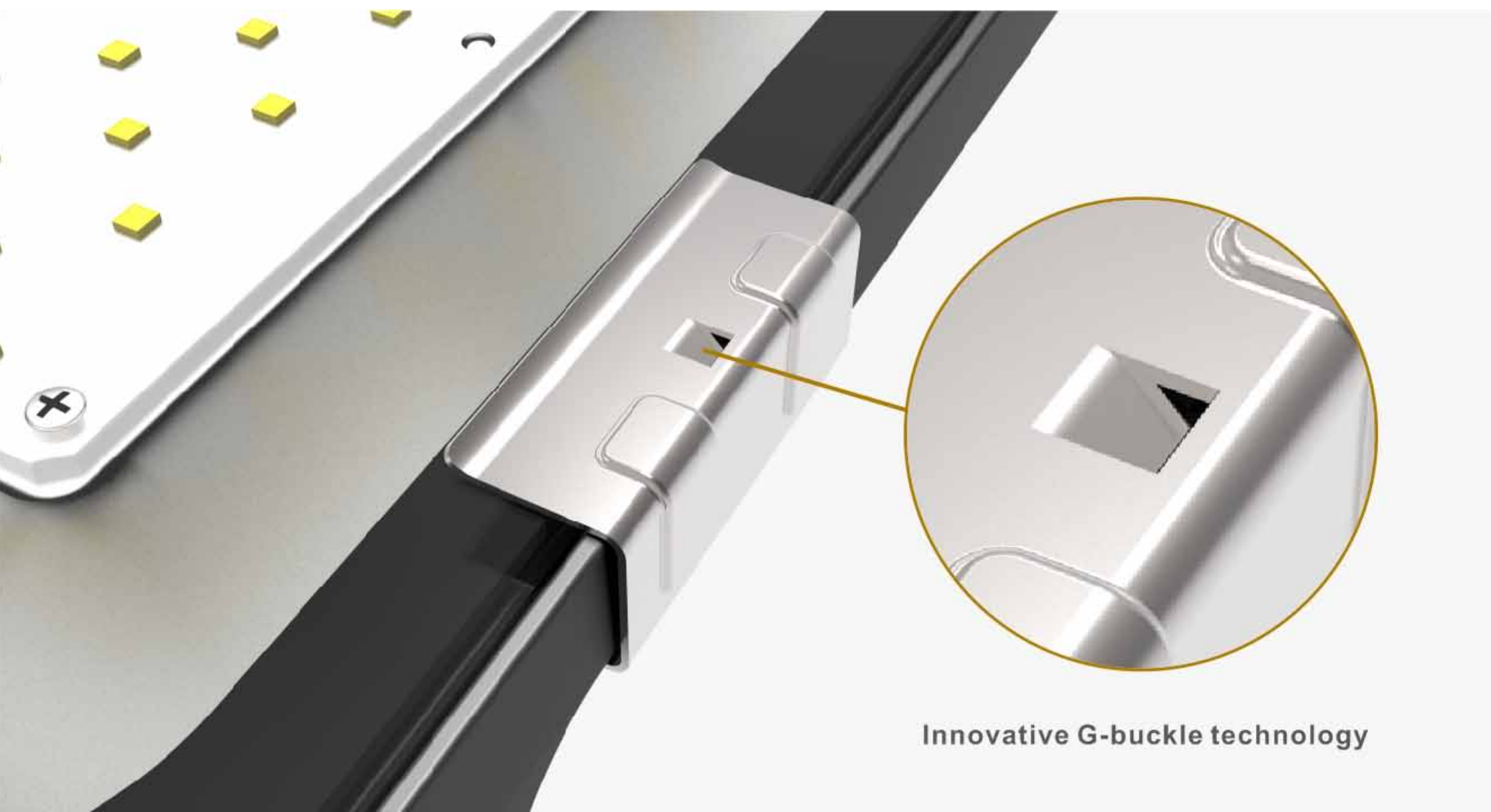

Innovative G-buckle technology



03 PROFESSIONAL LIGHT DISTRIBUTION AND LIGHT EFFICIENCY INCREASED BY 50%

The same condition, TG3A project-light lamp series by professional optical design, compared to traditional cast light lighting effect can be improved 50%

(Note: only as illustrated below, with a series of contrast principle is the same)

Effect of the light contrast figure

Unit : lm/W

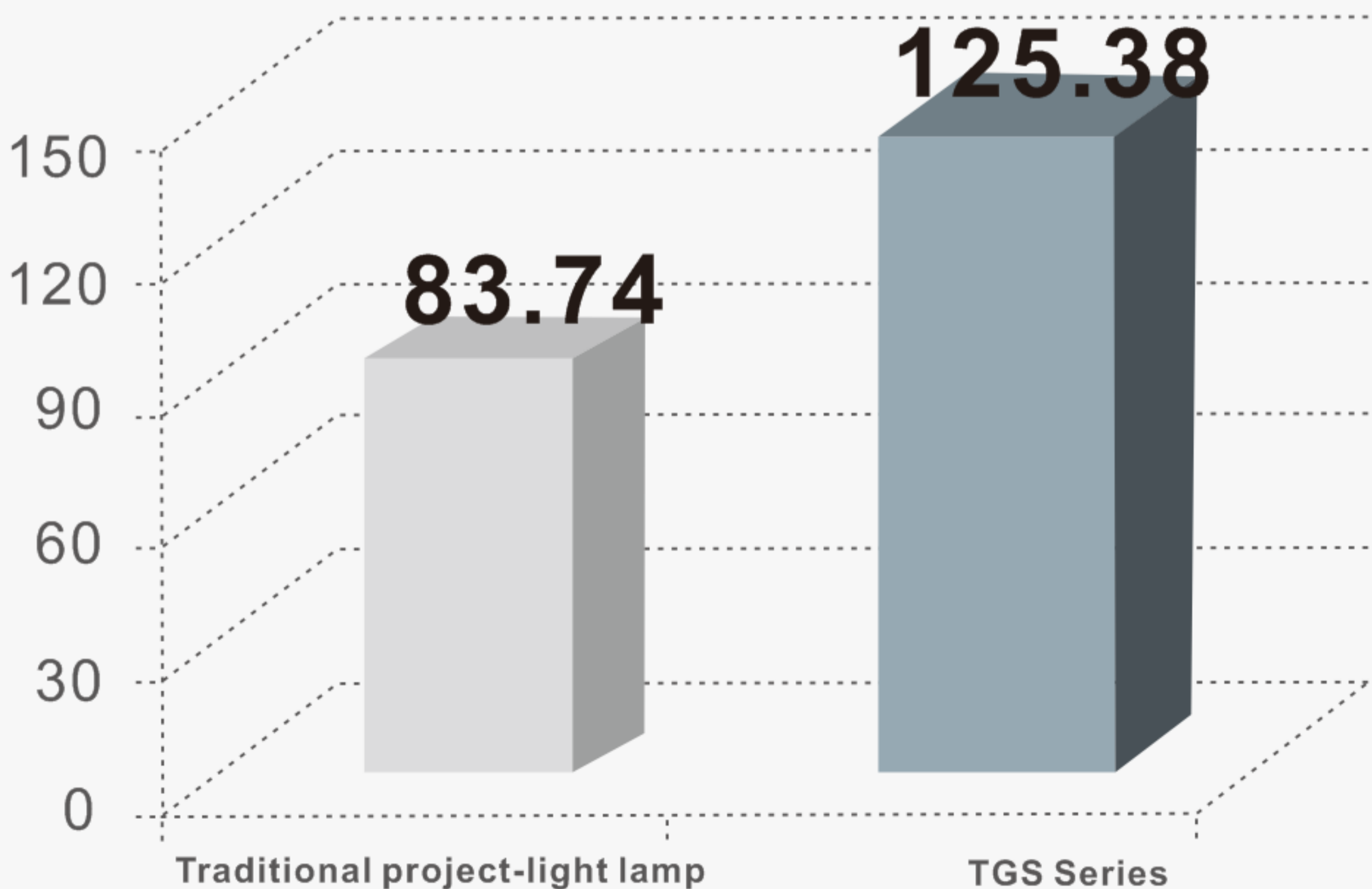

APPLICATION PLACES

Widely used in shopping mall, exhibition hall, parking lot, playground, gymnasium, billboards, park, sculpture, national green lighting project, building facade and public corridor, stair corridor and other indoor and outdoor lighting.

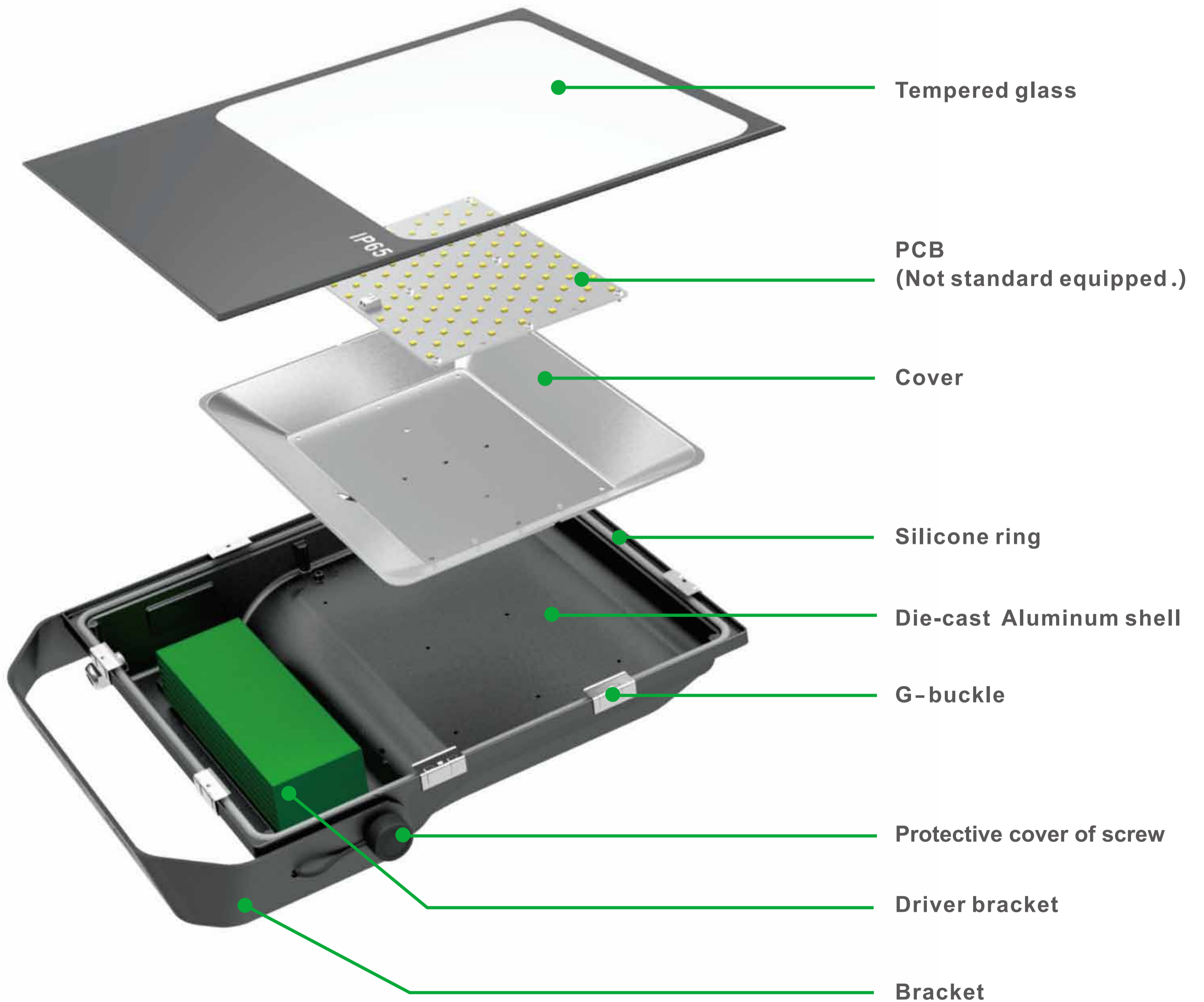
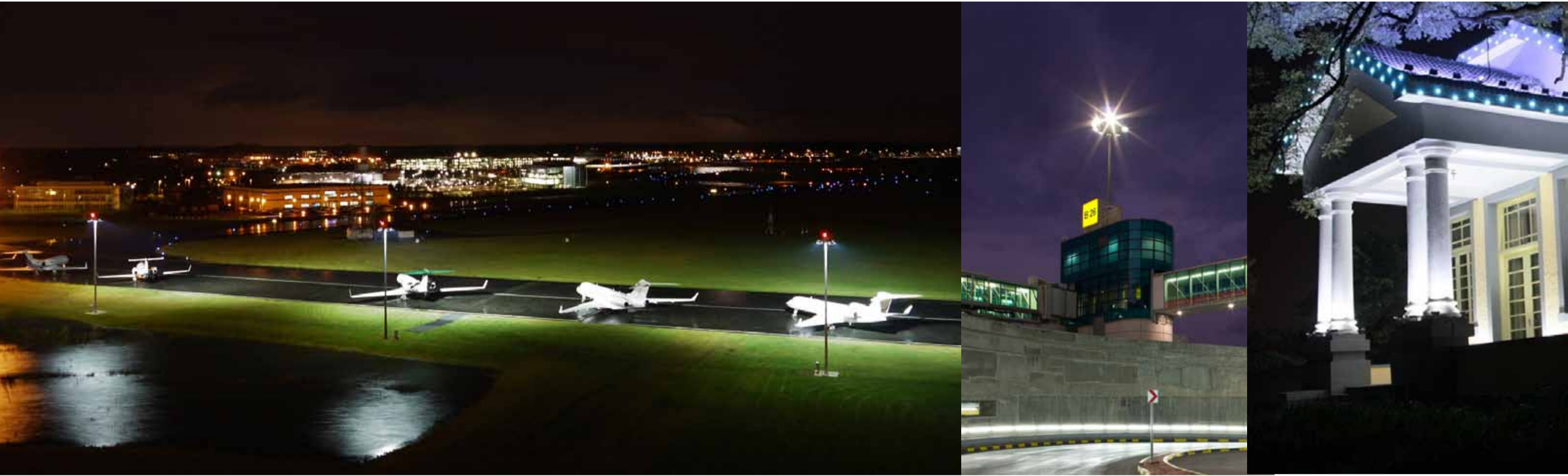

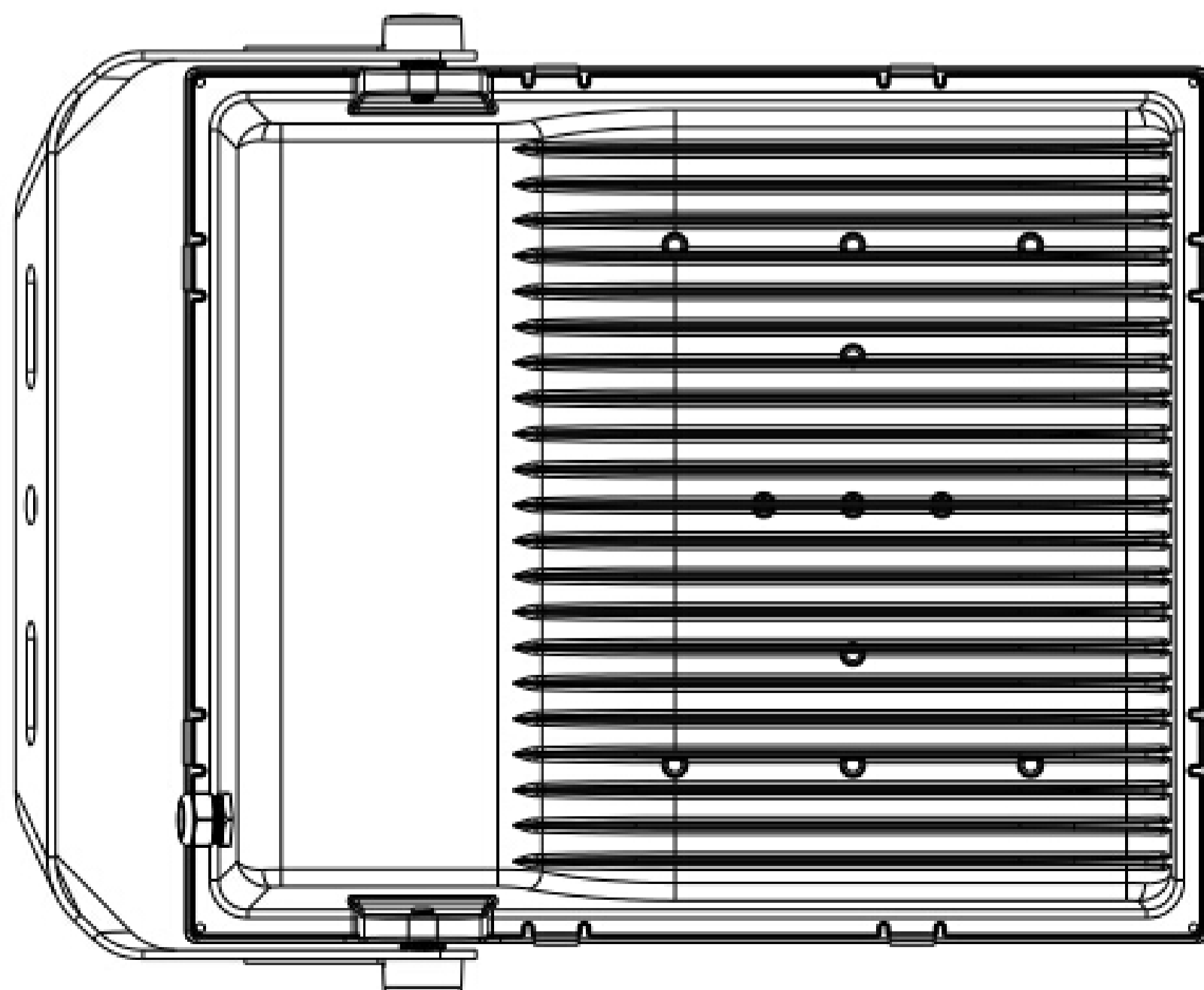
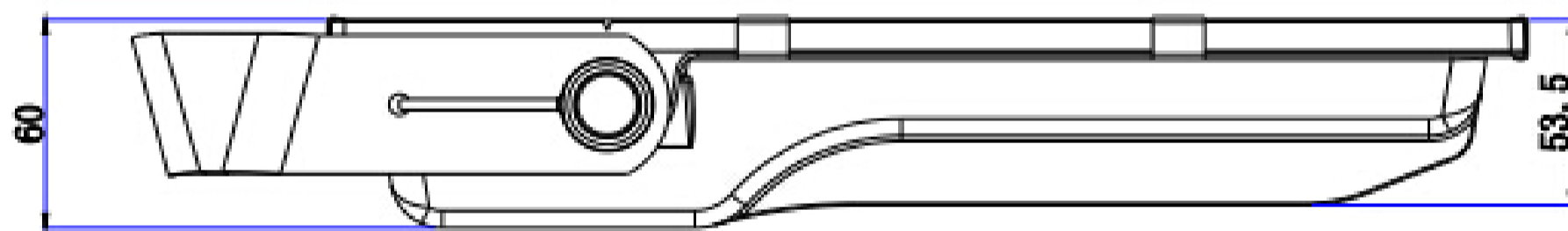
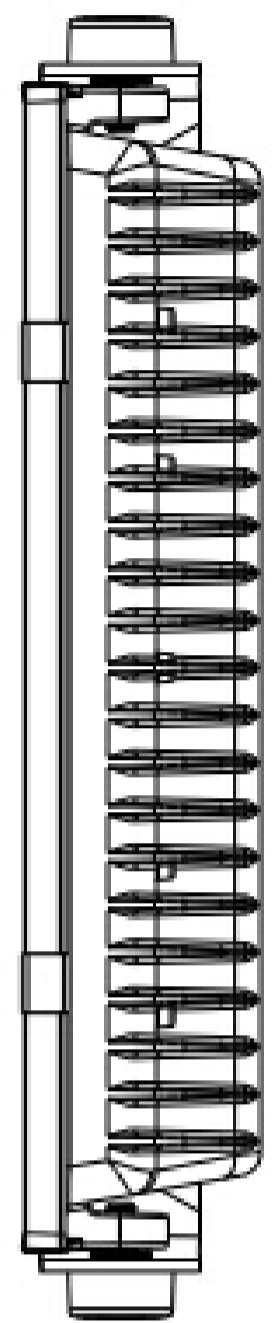
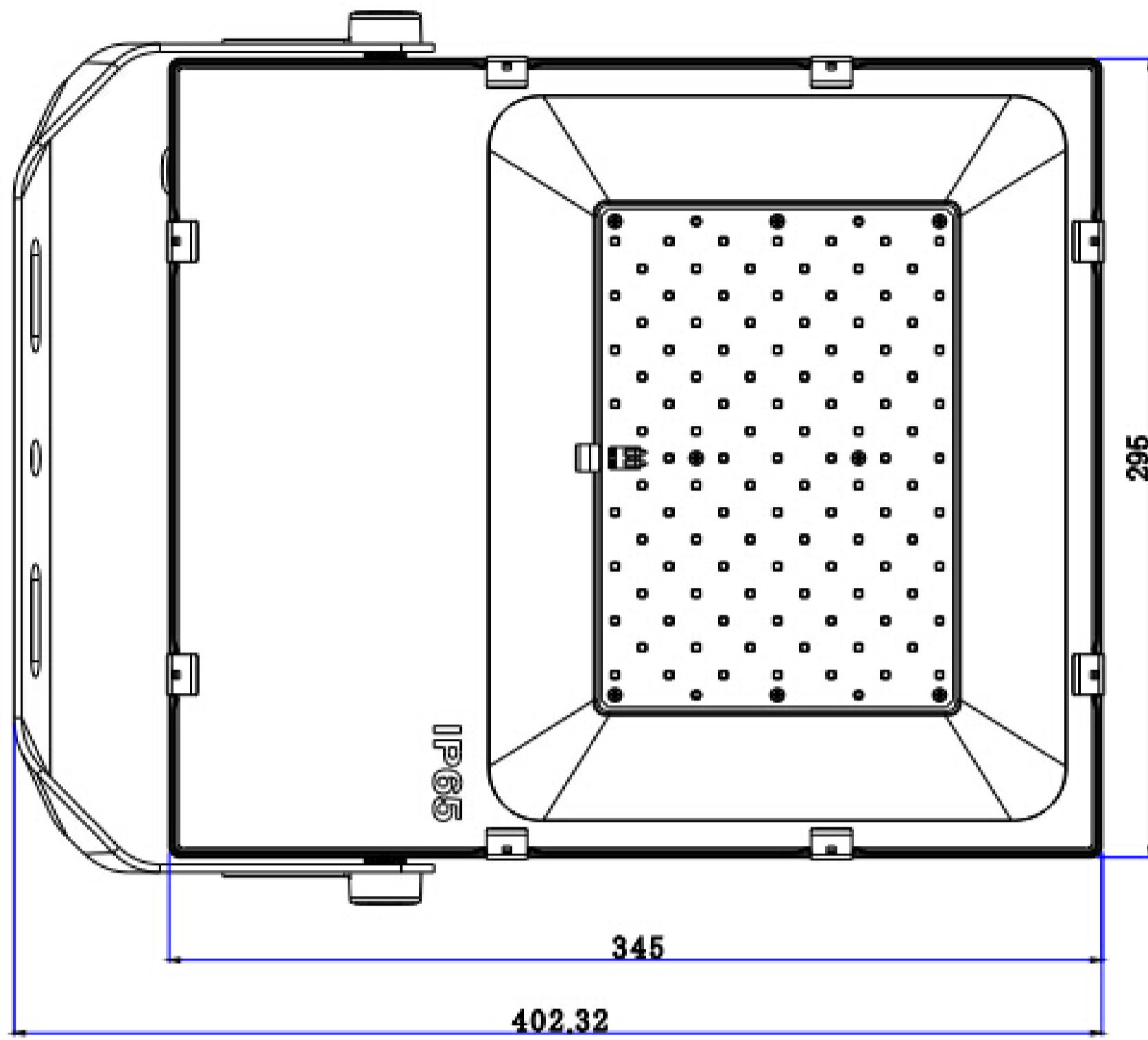
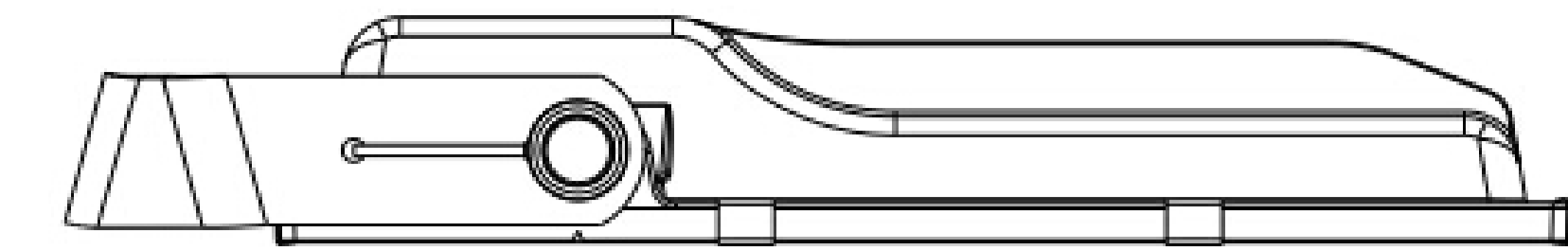
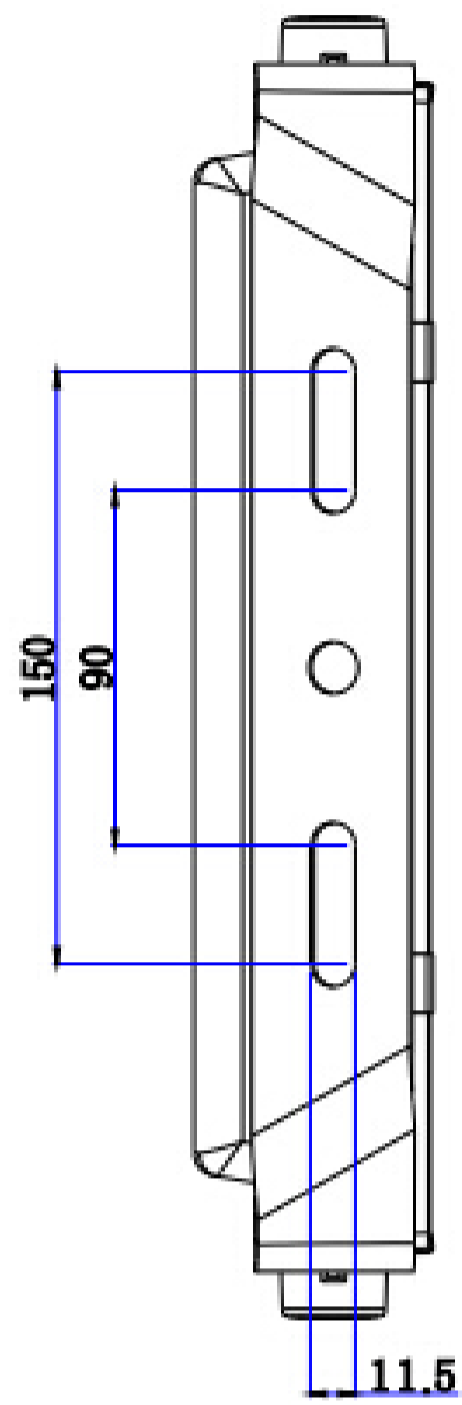

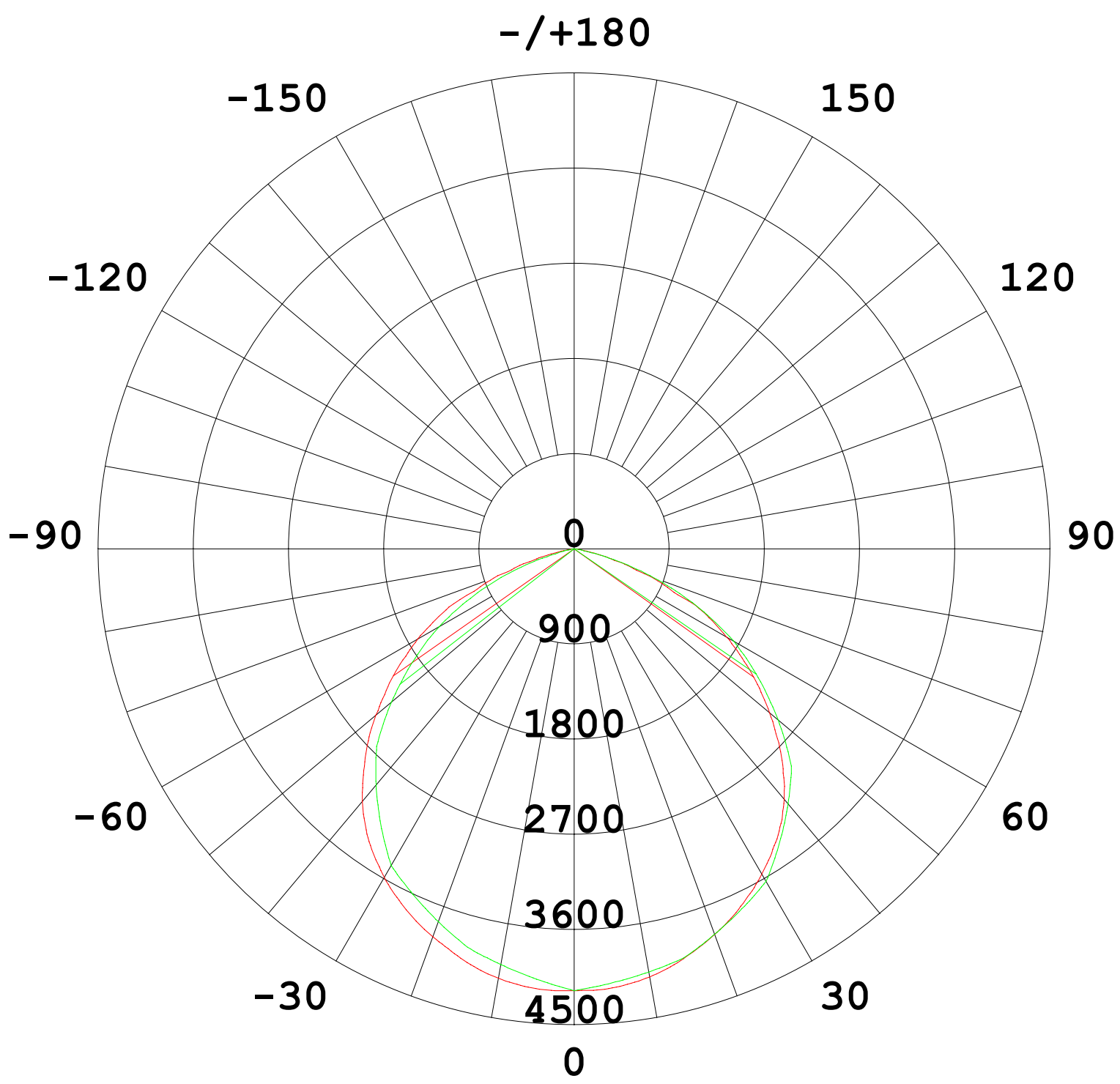

Height	Eavg, Emax	Diameter
9.843ft 3m	14.14, 43.12fc 152.2, 464.1lx	26.9ft 819.80cm
19.69ft 6m	3.536, 10.78fc 38.06, 116.0lx	53.79ft 1639.59cm
29.53ft 9m	1.571, 4.791fc 16.91, 51.57lx	80.69ft 2459.39cm
39.37ft 12m	0.8839, 2.695fc 9.514, 29.01lx	107.6ft 3279.18cm
49.21ft 15m	0.5657, 1.725fc 6.089, 18.56lx	134.5ft 4098.98cm

LX-TGS100

LED CHIP MODEL

POWER

Light source



PHILIPS
LUMILEDS

>100lm/ W
100W



X 100



OSRAM
Opto Semiconductors

>105m/ W
100W



X 100



NICHIA

>110lm/ W
100W



X 100