

Lifestyle
appliances limited

5-Burner LP Island Grill

Product size assembled:

H1240 x W2263 x D847mm (SRGG51103)

H1240 x W1708 x D635mm (SRGG51103A)

Rotisserie kit is an option, which is not included in every carton

Model No.: SRGG51103 / SRGG51103A

User Manual

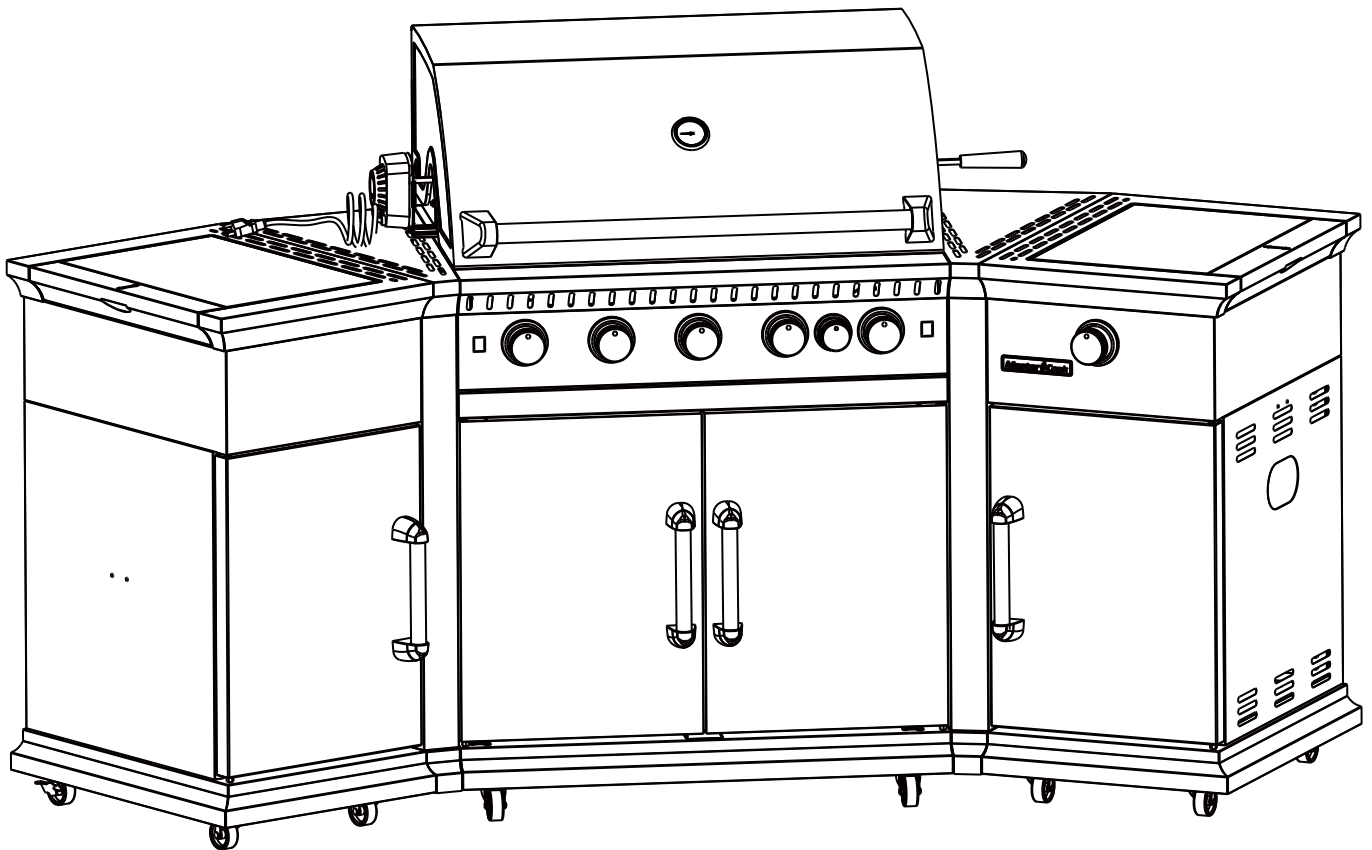

CE 0063-18

Keep the instructions for future reference.

Technical data

SUPPLIED BY:		Shinerich Industrial Ltd. 8/F, Noble Center No.1006, 3rd Fuzhong Road Futian District, Shenzhen, China				
Product Name		5-BURNER LP ISLAND GRILL	Model No.	SRGG51103 / SRGG51103A		
PIN Number		0063CT7097	ΣQ_n	22.2kW (1616g/h)		
Main burners ΣQ_n :		17kW (1237g/h)	Rotisserie burner ΣQ_n :		2.6kW (189g/h)	
Side burner ΣQ_n :		2.6kW (189g/h)				
Country		Category	Injector Size (Main Burner)	Injector Size (Rotisserie Burner)	Injector Size (Side Burner)	Gas & Pressure
<input type="checkbox"/> AT <input type="checkbox"/> CH <input type="checkbox"/> DE <input type="checkbox"/> SK		I _{3B/P(50)}	0.79mm	0.68mm	0.68mm	G30 Butane and G31 Propane at 50mbar
<input type="checkbox"/> BE <input type="checkbox"/> CY <input type="checkbox"/> DK <input type="checkbox"/> EE <input type="checkbox"/> FI <input type="checkbox"/> FR <input type="checkbox"/> GB <input type="checkbox"/> HU <input type="checkbox"/> IT <input type="checkbox"/> LT <input type="checkbox"/> NL <input type="checkbox"/> NO <input type="checkbox"/> SE <input type="checkbox"/> SI <input type="checkbox"/> SK <input type="checkbox"/> RO <input type="checkbox"/> HR <input type="checkbox"/> TR <input type="checkbox"/> BG <input type="checkbox"/> IS <input type="checkbox"/> LU <input type="checkbox"/> MT		I _{3B/P(30)}	0.89mm	0.78mm	0.78mm	G30 Butane and G31 Propane at 30mbar
<input type="checkbox"/> BE <input type="checkbox"/> CH <input type="checkbox"/> CY <input type="checkbox"/> CZ <input type="checkbox"/> ES <input type="checkbox"/> FR <input type="checkbox"/> GB <input type="checkbox"/> GR <input type="checkbox"/> IE <input type="checkbox"/> IT <input type="checkbox"/> LT <input type="checkbox"/> LU <input type="checkbox"/> LV <input type="checkbox"/> PT <input type="checkbox"/> SK <input type="checkbox"/> SI		I _{3+(28-30/37)}	0.89mm	0.78mm	0.78mm	G30 Butane at 28-30 mbar and G31 Propane at 37mbar
<p>⚠ CAUTION : USE OUTDOORS ONLY. If stored indoors, detach and leave cylinder outdoors. Read the instructions before using the appliance. Minimum clearance from side and back of unit to combustible construction: 100cm. WARNING: Accessible parts may be very hot. Keep young children away.</p>						
MADE IN CHINA						

Before you start

WARNINGS

- Read the instructions before using the appliance. Follow the steps in the order they are specified and please observe the safety warnings.
- Failure to observe these instructions can affect or damage the device and other objects and lead to personal injury.
- These instructions are part of the product. They should always be stored with the product and should be passed on to each subsequent user.
- Great care has been taken during production to remove sharp edges but you should handle all components with care to avoid possible injury.
- If ever in doubt, consult a qualified gas engineer before use.
- As an extra precaution WHEN LIGHTING FOR THE FIRST TIME ALWAYS TAKE EXTRA CARE. Keep your head and arms from hanging over the BBQ cooking surface.
- ALWAYS make sure barbecue appliance is completely cool before applying covers.
- In construction of this BBQ use all and only the components provided. Do not modify BBQ or parts. Any modification of the appliance may be dangerous.



CAUTION!

- KEEP OUT OF REACH OF CHILDREN and PETS DURING and AFTER USE.
- Do not store or use petrol or other flammable vapor or liquids in the vicinity.
- This appliance will become very hot during operation - always wear suitably protective heat proof gloves during use.
- WARNING: Accessible parts may be very hot. Keep young children away.
- Turn off the gas supply at the gas cylinder after use.
- ALWAYS close and disconnect from main gas supply cylinder after use and for storage.
- DO NOT MOVE THE APPLIANCE DURING USE.

DANGER!

If you smell gas:

1. Shut off gas supply to appliance.
2. Extinguish any open flame, avoid using any electrical appliance.
3. Open lid and ventilate the area.
4. Check gas connections with soap solution.
5. If odor still exists, immediately contact your gas supplier or fire department.

✓Do's

KEEP THIS APPLIANCE CLEAN (follow instructions herein) - To help avoid fat flash fires/ flare ups and therefore possible injury or damage to property, it is vital that this appliance is clean before it used.

Stand your barbecue on a safe, level surface, well away from flammable items such as wooden fences or over-hanging tree branches.

Protect from the elements and damp.

An adult should always be in charge of the BBQ. NEVER leave a hot barbecue unattended.

Always make sure the barbecue is fully extinguished and completely cool before moving, applying covers (not included) OR storing away.

X Dont's

Do not use indoors - Use outdoors only.

CAUTION! NEVER STORE a barbecue indoors unless it is fully cooled and the gas supply cylinder is disconnected.

Do not use the BBQ on a surface that may be damaged by excessive heat.

This is a gas appliance. Do not use any other type of fuel/ accelerants or lava rocks.

Further information

Proper use:

The barbecue is a gas barbecue for outdoor use. It is designed to be used exclusively in accordance with these instructions for preparing foods that are suitable for barbecue cooking. For private use only!

This appliance must be kept away from flammable materials during use.

Leak test all connections after each tank refilled or first use after a long period, by which the method is described in the "Connecting and disconnecting the gas bottle" part. This barbecue should be thoroughly cleaned and inspected on a regular basis, clean and inspect the hose before each use of the appliance. If there is evidence of abrasion, wear, cuts or leaks, the hose must be replaced prior to the appliance being operated.

Use only factory authorized parts. The use of any part that is not factory authorized is dangerous.

When cooking, fire extinguishing materials shall be readily accessible. In the event of an oil grease fire, do not attempt to extinguish with water. Use type B or type C dry chemical fire extinguisher or smother with dirt, sand or baking soda.

Operate on solid ground only, do not install or use in/on boats or recreational vehicles.

Always open barbecue lid carefully and slowly as heat and steam trapped within barbecue can severely burn you.

Move gas hoses as far away as possible from hot surface and dripping hot grease.

Keep all electrical cords away from a hot barbecue.

Turn off the gas supply at the gas cylinder after use.

When handling particularly hot components, protective gloves should be used.

Improper use:

Any other application or applications extending beyond the stated purpose are not authorised. This applies in particular to misuse involving the following possible scenarios:

- Do not operate the barbecue with coal or any fuel other than LPG.
- Do not operate the main barbecue as a stove using pots and pans.
- Do not operate the barbecue as a heater.
- Do not modify the appliance.
- Parts sealed by the manufacturer must not be altered by the user.
- Do not use the barbecue to heat materials and substances other than foods that are suitable for barbecuing.

The barbecue has been manufactured according to the general engineering rules – that were valid at the time manufacturing was started – and the requirement of the CE- sign. It is certified and approved by Kiwa Nederland B.V. (KIWA) (Test number 0063) The barbecue left the factory in good order and condition in terms of its function and safety.

- Never use an LP gas tank with damaged body, valve, collar, or footing.
- Do not store a spare LP gas tank under or near this appliance.
- The use of alcohol, prescription or non-prescription drugs may impair the ability to properly assemble or safely operate the appliance.

- Never use charcoal, lighter fluid, lava rocks, gasoline, kerosene, or alcohol within this product.
- Do not store or use gasoline or other flammable liquids or vapors within 25 feet (7.6m) from this appliance.
- Minimum clearance from sides and back of unit to combustible construction: 100cm. Do not use this appliance under overhead combustible surface.



During operation some parts of the barbecue can become very hot, particularly those close to the fire bowl.

Possible consequences:

- Severe burns from touching parts near the fire bowl.
- Fire or smouldering fire if flammable materials or substances are near the barbecue.

Safety measures prior to using the barbecue:

Select a place to set up the barbecue so that:

- There are not, and will not be, flammable material or substances nearby. Minimum distance to material or substances: No overhead obstruction above and 1m to the side. Distance to highly flammable materials or substances, e.g. walls: min. 1m.
- The barbecue is positioned firmly on a sufficiently large surface area. It must not be moved during operation.

Safety measures during barbecuing:

- Wear protective barbecue gloves.
 - Never leave the hot barbecue unattended.
- TAKE PARTICULAR CARE TO ENSURE THAT CHILDREN AND PETS ARE KEPT AWAY FROM THE BARBECUE.**
- Never fit the gas bottle right to next the barbecue. The gas bottle should be sited as far away from the appliance as possible without straining the hose. No part of the hose should touch any part of the appliance.



Liquid gas is highly flammable and explosive.

Possible consequences:

- Serious personal injury or damage to property if escaping gas ignites in an environment in which it is not controlled.

Safety measures:

- Only use the barbecue outdoors and ensure that the area is well ventilated.
- Protect the gas bottle and the gas hose from direct sunlight and other heat sources (max. 50degree C). Take special care to ensure that the gas hose does not touch any part of the hot barbecue.
- DO NOT place the gas bottle on the lower shelf, as it is too near the burner.

- DO NOT lean over the barbecue when igniting the gas flame.
 - Close the valve on the gas bottle after each use: (Turn the valve clockwise). Also turn off the control knobs (Turn knob fully clockwise).
 - Never leave the hot barbecue unattended. If the flame extinguishes, relight immediately or cut off the supply from the gas bottle.
 - When connecting the gas bottle, ensure that there are no ignition sources within a 5m radius. Take special care not to light any naked flames, do not smoke or switch on electric appliances (devices, lights, doorbells) etc. sparkover possible.
 - Before each use, check to ensure that all connections through which gas is supplied are sealed and intact.
 - If necessary, ensure that you replace the hose to meet with national requirements. (Always use hose-clips to secure the hose to the regulator and BBQ).
- If the connections for the gas supply are porous or faulty, the barbecue must not be used. This also applies, for example, to hoses or fittings that may have become blocked, as this can lead to a dangerous flashback.



- Liquid gas is heavier than oxygen. Therefore it settles on the ground and displaces the oxygen at that level.
Possible consequences:
- Suffocation resulting from a lack of oxygen if the gas concentration is allowed to rise sufficiently.
- Do not use the barbecue unless it's completely assembled and all parts are securely fastened and tightened.
- Do not leave a lit barbecue unattended, especially keep children and pets away from barbecue at all times.
- Do not move the appliance during use.
- Never cover the entire cooking area.
- Never obstruct the ventilation openings of the cylinder compartment.
- Do not use power tools to construct this product.
- Do not over tighten screws or bolts.
- Do not sit or stand on the product.
- Do not use this product if parts are missing, damaged or worn.
- Never use scourers, abrasive or chemical cleaners.

Assembly

Please read these instructions carefully before assembly and use.

Caution: Whilst every effort has made in manufacture of your barbecue to remove any sharp edge, you should handle all components with care to avoid accidental injury.

Please use protective gloves when assembling this product.

Assembly of the barbecue involves many large components; it is advisable to have two people assemble the unit.

When you are ready to start, make sure that you have the right tools, plenty of space and a clean, dry area for assembly.

To avoid losing any small component or hardware, assemble your product on a hard level surface that does not have cracks or openings.

To avoid damage to soft floor or carpet, do not assemble or move the appliance on soft floor or carpet.

Check the pack and make sure you have all the parts listed.

Please refer to the parts list and assembly diagram as necessary. During assembly children should be kept away from the product due to possible risk of injury.

Make sure all the plastic protection rip off before assembling.

Follow all steps in order to properly assemble your product.

Do not force parts together as this can result in personal injury or damage to the product.

When applicable, tighten all hardware connections by hand first, once the step is completed, go back and full tighten all hardware.

Ensure that this product is fully assembled as illustrated before use.

Number of people required to assemble

Two people to assemble and lift.

Time to assemble



Tools required

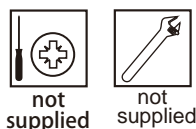

Connecting and disconnecting the gas bottle

Parts and tools needed

- Gas bottle - Standard LPG gas bottle with equal or less than 5kg to 13kg LPG (e.g. propane or butane). These are available at DIY store or liquid gas suppliers.

The following parts are excluded in delivery. They correspond to the standards applicable in the country to which they have been supplied.

- Gas hose- CE approved hose of sufficient length, allowing installation without any kinks (Length shall not exceed 1.5m). The tube shall be readily visible across its entire length for inspection after installation.
- Pressure reducer – Preset and CE-approved pressure Regulator, operating pressure suitable for the utilized gas cylinder. This type of pressure reducer is also available from your local dealer.

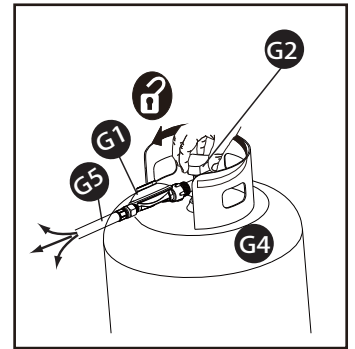
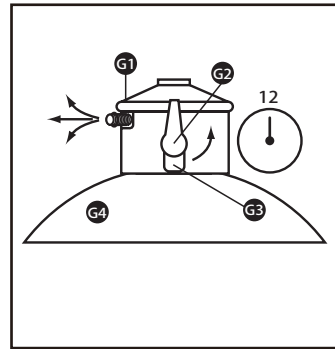
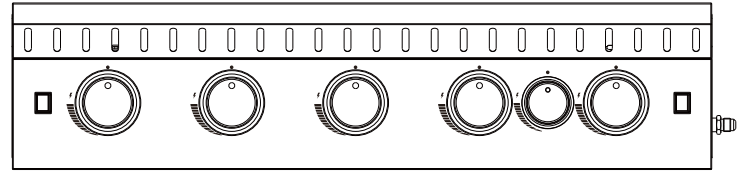

Liquid gas is highly flammable and explosive.

Possible consequences:

- Serious personal injury or damage to property if escaping gas ignites in the environment which it is not controlled.

Safety measures:

- When connecting the gas bottle, ensure that there are no ignition sources within a 5m radius.
- Take special care not to light any naked flames, do not smoke or switch on electric appliances (devices, lights, doorbells) etc. sparkover possible.
- If necessary, ensure that you replace the hose to meet with national requirements.
- Ensure the flexible tubing is routed so that there are no kinks and it is not subject to twisting.
- Do not obstruct the ventilation openings of the cylinder compartment.

Function

- If the bottle valve (G2 at 12 o'clock setting or anti-clockwise rotate to the end) and the control knob are opened, gas flows through the gas hose G5 and the setting device (beneath the front panel) into the burner.
- While reaching 1/4 position of each control knob, a spark will be emitted from the electrode on the burner that then ignites the gas. The heat output can be adjusted for the left, middle, right and side burner by turning the control knob position 1/4 to 1/2.

Note

- If the barbecue is not in use for long periods, cut off the supply from the gas bottle and store properly. Disconnect the regulator from the gas bottle. The gas bottle must be stored outdoors.
- Fit the gas bottle with a cap nut and safety cap.

Operational Elements:

POSITION	DESCRIPTION	FUNCTION
G1	Regulator	Reduce gas pressure
G2	Operating lever/ Cylinder valve	Separate safety facility with 2 settings: 9 o'clock setting or rotate clockwise to the end: Turn the gas off and connect/disconnect the gas bottle. 12 o'clock setting or rotate anti-clockwise to the end: Gas on
G3	Release button	Disconnect the regulator from the bottle valve
G4	Gas bottle with bottle valve	Fuel container
G5	Gas hose with hose clip	Direct gas to burner

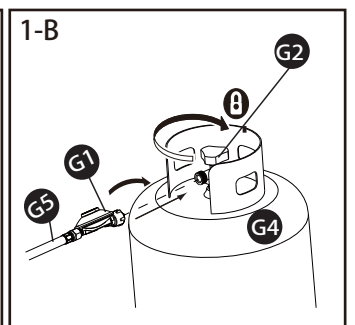
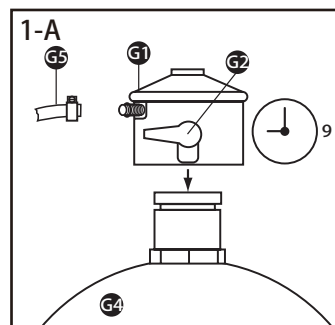

Connecting and disconnecting the gas bottle

- 1 Select a suitable position to set up the barbecue. Ensure that: They are not, and will not be, flammable materials or substances nearby. Minimum distance to materials or substances: 2m above and 1m to the side; distance to flammable materials or substances - min 7.6m.
2. Position the gas bottle G4 next to the barbecue. Never lay the gas bottle on its side or place on the lower shelf. The gas hose G5 must not be bent or be under tension.

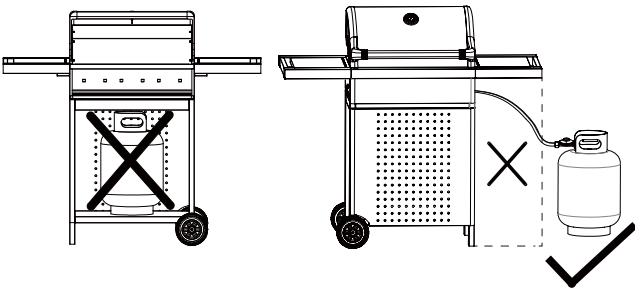

3. Check that the gas bottle G4 and the regulator G1 are in good working order. Also check that there is an intact seal in the regulator G1. Do not use any other seals.
4. Turn the operating lever G2 to the 3 o'clock position and press the regulator G1 on the valve of the gas bottle G4 until you hear a click.
5. Check they are correctly connected by pulling the regulator G1 upwards. The regulator must not disconnect from the bottle valve.
6. Check the connection between the regulator G1 and the gas hose G5 and the gas hose G5 to the valve to ensure they are secure.
7. Open the bottle's valve by turning the operating lever G2 to the 12 o'clock position. Use a standard leak detector to ensure all connections are tight. Failure to do so may result in fire. Please observe the instructions for the leak indicator. Never check leaks if there is an open flame. Listening for leaks is not a reliable method of detection.

Confirm all barbecue control knobs are in the off "•" position. Open the gas control valve on gas cylinder. Check for leaks by brushing soap solution over all gas system joints, including all valve connections, hose connections and regulator connections. NEVER USE AN OPEN FLAME to test for leaks at anytime. If bubbles form out of any of the tank there is a leak. If the connection is not sealed, immediately close the bottle valve (turn the operating level G2 to the 3 o clock position) and tighten the connection or replace the leaking part. Repeat the leak test annually, and whenever the gas cylinder is repaired or replenished.

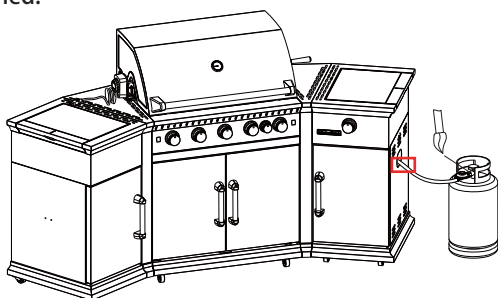

Shutting off the gas bottle (Fig.2-A, 2-B)

1. Close the bottle valve (Turn the operating lever G2 to the 9 o'clock position).
2. Press the release button G3 and pull the regulator G1 upwards. Or anti-clockwise rotate the nut on regulator G1 to release the regulator G1.
3. Store the regulator G1 with the gas hose under the barbecue. Ensure the hose is not kinked or twisted in any way.
4. Store the gas bottle correctly:
 - Fit the gas bottle valve with cap nut and safety cap.
 - Do not store the gas bottle in areas below ground level, or in or near stairways, hallways or passages for pedestrians or cars between buildings. Always store gas bottle outside.
 - Always store gas bottles upright, even if they are empty!

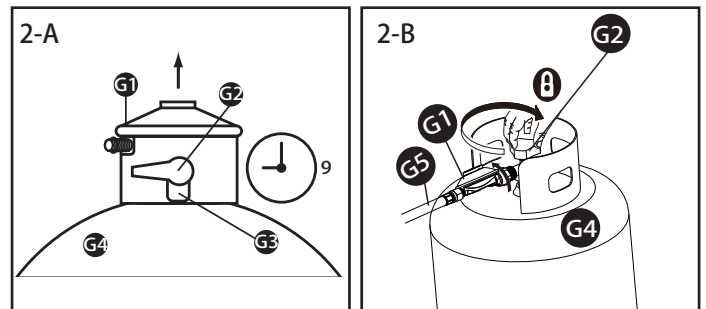

Operation

Warnings

Before proceeding, make certain that you have assembled the appliance according to instructions.
Use your Barbecue at least 100cm away from any wall or surface.
Never use your gas barbecue in a building, garage, shed, breezeway, or any other enclosed area.
Never obstruct the flow of ventilation air around your gas barbecue housing.

Before lighting

Inspect the gas supply hose prior to turning the gas "ON". If there is evidence of cuts, wear or abrasion, it must be replaced prior to use. Check leakage before use. Do not use the barbecue if the odor of gas is present.

Preparation before cooking

To prevent foods from sticking to the cooking grill, please use a long handled brush to apply a light coat of cooking or vegetable oil before each barbecuing session. (Note: When cooking for the first time, coating color may change slightly as a result, this is normal and should be expected.)

Lighting the barbecue:

1. Read the instructions before using the appliance.
2. Open lid.
3. Ensure knobs are in "●" position.
4. Connect regulator with cylinder, then turn on.
5. Push and turn control knob anti-clockwise to approx 1/4 position. Keep control knob pressed for 3 to 5 seconds until the burner is lit. Then release knob. Adjust the flame by turning control knob between 1/4 and 1/2 areas.
6. When igniting the rotisserie burner, keep control knob pressed for 30 seconds once burner is lit.
7. If ignition dose not occur within 5 seconds, turn control knob(s) to "●". Wait 5 minutes to allow gas to dissipate and repeat lighting procedure.
8. To turn off, turn control knob clockwise until it locks in "●" position.
9. Turn off the gas supply at the gas cylinder after use.

Switching on the side burner:

Repeat the step starting from step 2 above, but using the control knob for side burner.

Match-Lighting

If the burner still fails to light after several attempts, try the manual ignition procedure below.

- 1, Open BBQ lid.
- 2, Ensure all the burners control knobs are in the "●" position.
- 3, Slowly turn on the gas at the LP gas cylinder valve or regulator if it is not already on.
- 4, Place a match in the end of the match holder, strike the match.
- 5, Use the holder to slide the lit match through the cooking grates or cooking griddle and the front of the heat tent to the left of the burner you wish to light.
- 6, Press and turn the burner control knob to 1/4 position.
- 7, If the burner does not light within 5 seconds, turn the burner control knob to "●", wait 5 minutes for gas to clear, and try again.
- 8, When lit, turn the control knob to the desired heat setting.

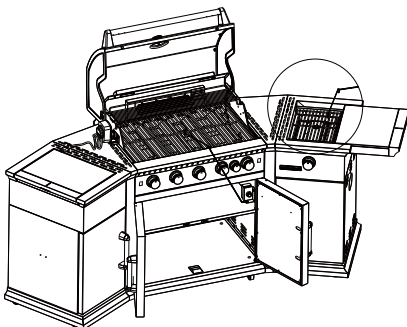

Using the rotisserie burner

Your grill mayn't be equipped with motor, motor bracket and rotisserie fork. The instructions below include operation for grills equipped with a rotisserie burner. Be sure to follow the instructions appropriate for your grill.

⚠ WARNING

- To protect against electric shock, do not immerse cord or plugs in water or other liquid. Do not use the equipment in the rain.
- Unplug from outlet when not in use and before cleaning. Allow to cool before putting on or taking off parts.
- Do not operate any outdoor cooking gas appliance with a damaged cord, plug or after the appliance malfunctions or has been damaged in any manner. Contact your retailer for repair.
- Do not let the cord hang over the edge of a table or touch hot surfaces.
- Do not use this outdoor cooking gas appliance for purposes other than intended.
- When connecting, first connect plug to the outdoor cooking gas appliance, then plug appliance into the outlet.
- Use only a Ground Fault Interrupter (GFI) protected circuit with this outdoor cook gas appliance.
- Never remove the grounding plug or use with an adapter with 2 prongs.
- Use only extension cords with a 3 prong grounding plug, rated for the power of the equipment, and approved for outdoor use with a W-A marking.

ROTISSERIE OPERATING INSTRUCTIONS

IMPORTANT: Do not use the rotisserie burner and the main burner at the same time while rotisserie is in use.

Do not use side burners when the rotisserie is in use to prevent burns.

1. Slide one of the meat prongs onto the rod (prongs toward the food). Center the food on the rod, then secure with the other meat prongs. Then push the meat forks firmly together. Tighten the thumbscrews. It may also be necessary to wrap food with butcher's string, (never use nylon or plastic string) to secure loose portions.
2. Once the food is secure, insert the pointed end of the rotisserie rod into the motor assembly and rest the other end on the support on the right-hand side of the grill.
3. Check for clearance with the cooking grates. The grates can be removed if additional clearance is required.
IMPORTANT: If grates are removed, make sure food is not touching the burner(s).
4. Place a shallow drip pan underneath the food to catch drippings and make for easier cleanup.
5. Plug the unit into an electrical outlet. Turn the power switch to the ON position to start the rotisserie motor. To begin, turn burner onto the lowest setting.
6. Check for constant speed of the rotisserie rod. If the rod does not turn at a constant speed, reposition the food on the forks. An unbalanced rotisserie rod will damage the motor.
7. Check food frequently and adjust burner temperature based on observations. This will require some experimentation as each grill has different heating and cooking characteristics.

End of cooking session

After each cooking session, turn the barbecue control knob burners to the "Max" position and burn for 5 minutes. This procedure will burn off cooking residue, thus making cleaning easier. Make sure the hood is open during this process. When you have finished using your barbecue, turn all the control valves fully clockwise to the OFF "●" position, then switch off the gas at the bottle. Wait until the barbecue is sufficiently cool before closing its hood.

Cleaning and maintenance

Tips for better cookouts and longer barbecue life

- 1, Use the upper cooking grid (warming rack) for keeping cooked food warm, toasting breads or cooking delicate foods in aluminum foil pouches.
- 2, Use the side burner of this appliance like a normal kitchen range for boiling, sautéing or frying.
- 3, To reduce flare-up, keep barbecue clean, use lean cuts of meat and avoid cooking on very high temperature.
- 4, Place delicate foods like fish and vegetables in aluminum foil pouches and indirect cook or place on upper cooking levels (warming rack).
- 5, To avoid losing natural juice, use long handled tongs or spatulas instead of forks and turn foods over just once during cooking.
- 6, When direct cooking adjust your burners to different levels so foods can be prepared to different internal temperatures in the same time frame.
- 7, Try water pans to reduce flare-ups and cook juicier meats. Before starting barbecue remove cooking grids and place a heavy duty shallow pan directly on heat plates. Fill half way with water, fruit juices or other flavored liquids. Replace cooking grids and position food over the loaded pan.
- 8, Rotisseries, grill baskets, vertical poultry holders and other accessories can enhance your experiences, reduce cooking time and aid in clean-up.
- 9, Clean cooking grids and racks after every use with a quality grill brush designed for your grid material. Wear protective gloves and gently remove the build-up while grids are hot.
- 10, After every use, allow barbecue to cool down. Then protect clean cooking grids with a light coat of cooking oil, empty grease pan, wipe outside surfaces with a suitable kitchen cleaner and protect surfaces with a quality cover that properly fits your barbecue.

Regularly clean your barbecue between uses and especially after extended periods of storage.

Ensure the barbecue and its components are sufficiently cool before cleaning.

Never douse the barbecue with water when its surfaces are hot. Never handle hot parts with unprotected hands.

In order to extend the life and maintain the condition of your barbecue, we strongly recommend that the unit be covered when left outside for any length of time, especially during the winter months.

1. Cooking Grill

Clean with hot soapy water. To remove any food residue, use a mild cream cleaner on a non-abrasive pad. Rinse well and dry thoroughly.

2. Burner Maintenance

In normal usage, burning off the residue after cooking will keep the burner clean. The burner should be removed and cleaned annually, or whenever heavy build-up is found, to ensure that there are no signs of blockage (debris, insects) in either the burner portholes or the venturi tubes. Use a pipe cleaner to clear obstructions. A wire brush can be used to remove corrosion from the burner surfaces.

When refitting the burner, be careful to check that the venturi tubes of the burner fit over the valve outlets.

The electrode on the burner can be bent or may snap off during cleaning.

Possible consequences:

- Burner no longer light.

Safety measures:

- Take special care when cleaning the area around the burner



3. Barbecue Body

Regularly remove excess grease or fat from the barbecue body with a soft plastic or wooden scraper.

It is not necessary to remove all the grease from the body. If you need to clean fully, use hot soapy water and a cloth, or nylon-bristled brush only. Remove cooking surfaces and burners before full cleaning. Do not immerse the gas controls or manifold in water. Check burner operation after carefully refitting into body.

4. Fixings

Annual checking and tightening of metal fixings is recommended.

5. Storage

Store your barbecue in a cool dry place. Cover the burners with aluminum foil in order to prevent insects or other debris from collecting in burner holes. If the barbecue is to be stored indoors, the gas cylinder must be disconnected and left outside. The gas cylinder should always be stored outside, in a dry, well-ventilated area, away from any sources of heat or ignition. Do not let children near the gas cylinder.

Environment information and disposal measures















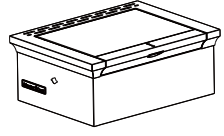
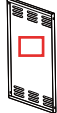
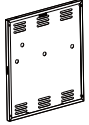
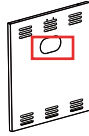

- To dispose of the barbecue, disassemble it into its individual parts. Recycle the metal and plastic parts.

Troubleshooting

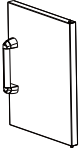
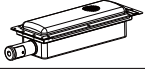
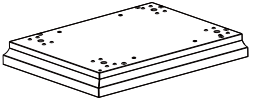











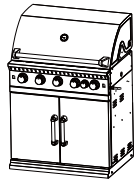
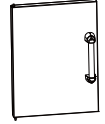

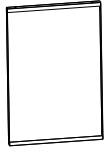
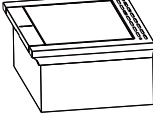



PROBLEM	POSSIBLE CAUSE	PREVENTION/CURE
Burner will not light using igniter	Wires or Electrode covered with cooking residue	Clean wire and/or electrode with rubbing alcohol
	Electrode and burners are wet	Wipe dry with cloth
	Electrode cracked or broken – sparks at crack	Replace electrode
	Wire loose or disconnected	Reconnect wire or replace electrode/wire assembly
	Wire is shorting (Sparking between igniter and electrode)	Replace igniter wire/electrode assembly
Burner will not light with match	No gas flow	Check if LP gas cylinder is empty. If empty, replace or refill, or else refer to “sudden drop in gas flow or reduced flame height”
	Coupling nut and regulator not fully connected	Turning the coupling nut about one-half to three quarters additional turn until solid stop. Tighten by hand only, Do not use tools.
	Obstruction of gas flow	Clear burner tubes, check for bent or kinked hose.
	Spider webs or insect nest in venturi	Clean venturi
	Burner ports clogged or blocked	Clean burner ports
Sudden drop in gas flow or reduced flame height	Out of gas	Replace or refill LP gas cylinder
	Excess flow, safety device may have been activated	Turn control knobs to OFF “●”, wait 30 seconds and light barbecue. If flames are still too low, reset the excessive flow safety device by turning control knobs OFF “●” and LP gas cylinder valve to “CLOSED”. Disconnect regulator. Turn control knobs to “HIGH”, wait 1 minute. Then turn control knobs to OFF “●”, and reconnect regulator and leak check connections. Slowly turn LP gas cylinder valve to “OPEN”, wait 30 seconds and then light barbecue per lighting instructions.
Irregular flame pattern, flame does not run the full length or burner	Burner ports are clogged or blocked	Clean burner ports.
Flame is yellow or orange	New burner may have residual manufacturing oils	Burn barbecue for 15 minutes with the lid closed
	Spider webs or insect nest in venturi	Clean venturi
	Food residue, grease or seasoning salt on burner	Clean burner
	Poor alignment of valve to injector venturi	Assure burner venturi is properly engaged with injector
Flame blow out	High or gusting winds	Do not use barbecue in high winds
	Low on LP Gas	Replace or refill LP gas cylinder
	Excess flow valve tripped	Reignite the BBQ
Persistent grease fire	Grease trapped by food buildup around burner system	Turn control knobs to OFF “●”, Turn LP gas tank valve to “CLOSED”. Leave lid in open position and let fire burn out. After barbecue cools, remove and clean all parts
Flashback (fire in burner tube(s))	Burner and/or burner tubes are blocked	Clean burner and/or burner tubes
Inside of lid is peeling (like paint peeling)	The lid is stainless steel not painted	Baked on grease buildup has turned to carbon and is flaking off. Clean thoroughly.

Fixtures and Fittings

Components supplied (not actual size)





Ref	Description	Visual	Qty
1	Warming rack		1
2	Cooking grate		3
3	Flame tamer		5
4	Rotisserie fork		1
5	Grease tray		1
6	Front support pole		2
7	Right triangle tabletop		1
8	Side burner cooking grate		1
9	Side burner assembly		1
10	Right cabinet rear panel		1
11	Right cabinet left panel		1
12	Right cabinet right panel		1
13	Connection bar		2
14	Right cabinet front door		1
15	Right side burner		1
16	Right cabinet bottom panel		1
17	Foot bracket		8
18	Locking caster		6
19	Triangle bottom panel		2
20	Connection panel		2
21	Battery compartment		1
22	Battery compartment holder		1

Components supplied (not actual size)

Ref	Description	Visual	Qty
23	Cart shelf		1
24	Match lighter		1
25	Grill body and cart assembly		1
26	Left cabinet front door		1
27	Left cabinet bottom panel		1
28	Left cabinet left panel		1
29	Left cabinet rear panel		1
30	Left side shelf		1
31	Ice bucket holder		1
32	Ice bucket		1
33	Left cabinet right panel		1
34	Left triangle tabletop		1
35	Motor		1
36	Motor bracket		1
37	Hook		2
38	Non-locking caster		6
39	Transformer		1
40	Hose assembly		1
41	Side burner valve		1
42	Control knob		6
43	Control knob bezel		6
44	Battery		1 (Not included)

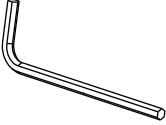
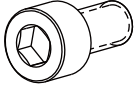
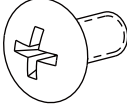
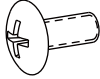
Fixtures and Fittings

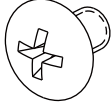
Fittings supplied (not actual size)

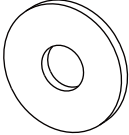
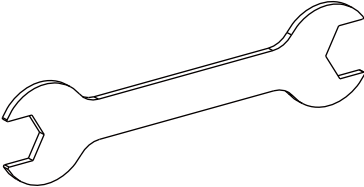
Ref	Dimensions	Visual	Qty
AA	6 x 12 mm washer		2
BB	Allen wrench		1
CC	M6 x 12 bolt		12
DD	M6 x 14 screw		53
EE	M4 x 10 screw		42
FF	D4 washer		32
GG	M6 x 10 screw		2
HH	M6 nut		2
II	M4 nut		32
JJ	6 x 18 mm washer		4
KK	Wrench		1

Getting to know your product

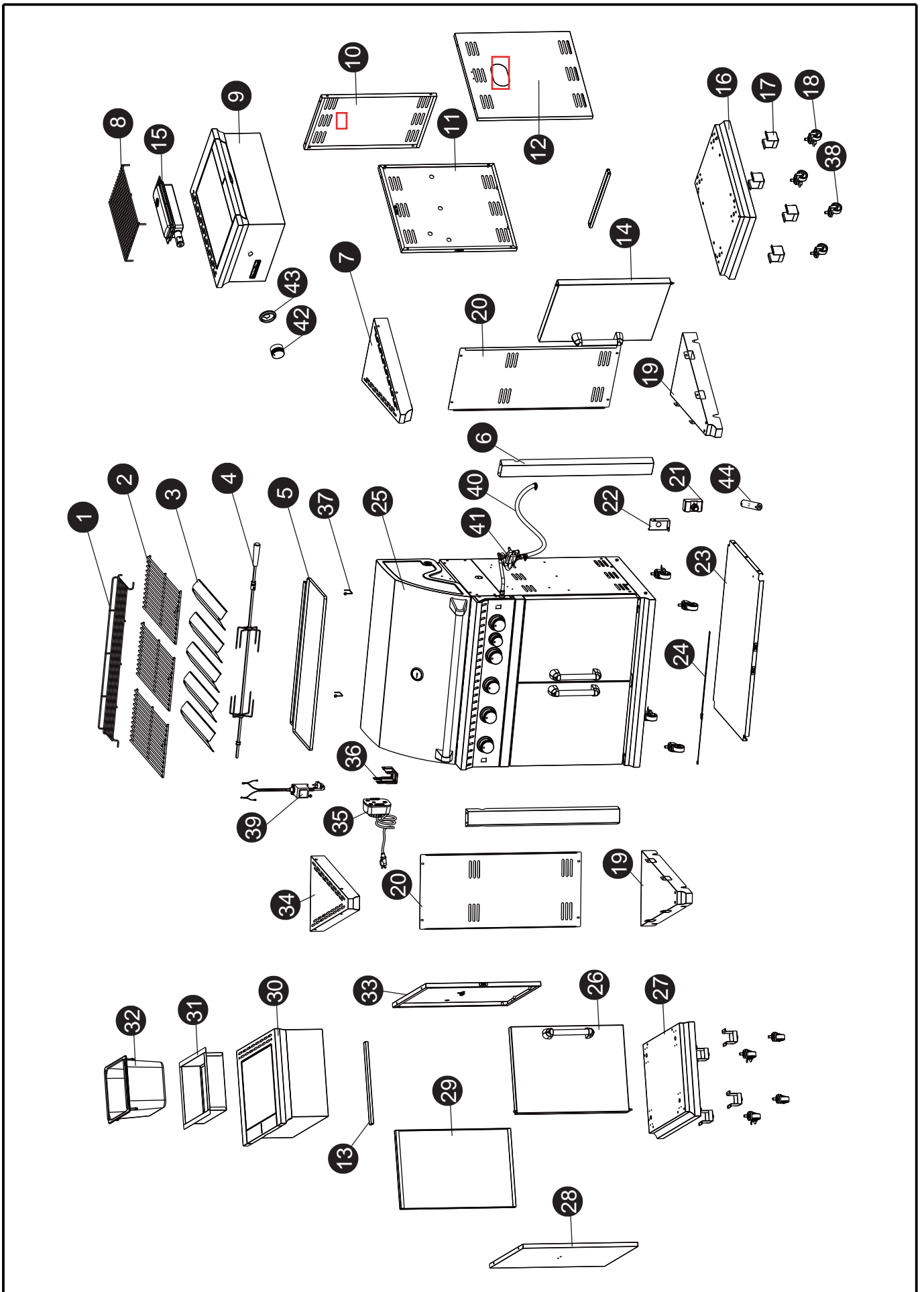

Assembly instructions

SRGG51103

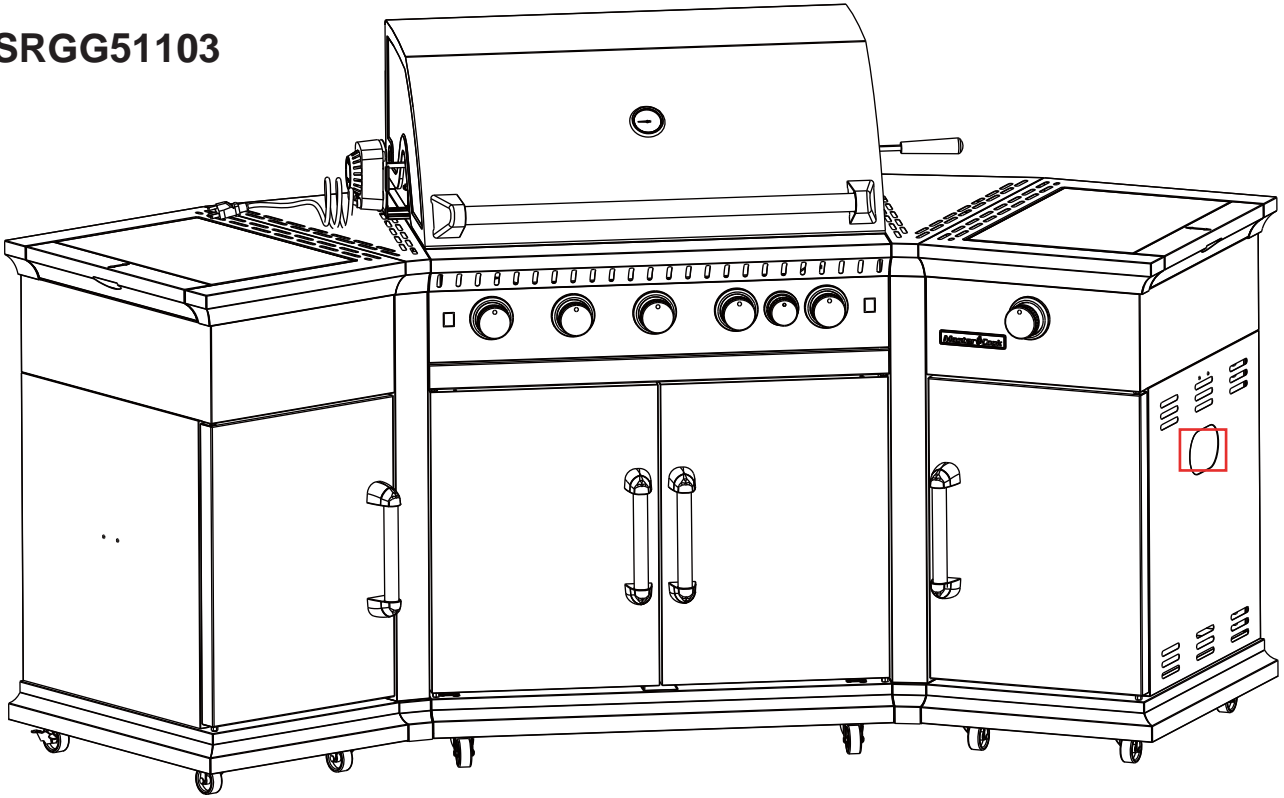

Step 1.1 - 1.2 - 1.3 - 1.4 - 2.1 - 2.2 - 2.3 - 2.4 - 3.1 - 3.2 - 4.1 - 4.2 - 5.1 - 5.2 - 5.3 - 6 - 7a - 8a - 9 - 10.1 - 10.2 - 11a - 12a

SRGG51103A

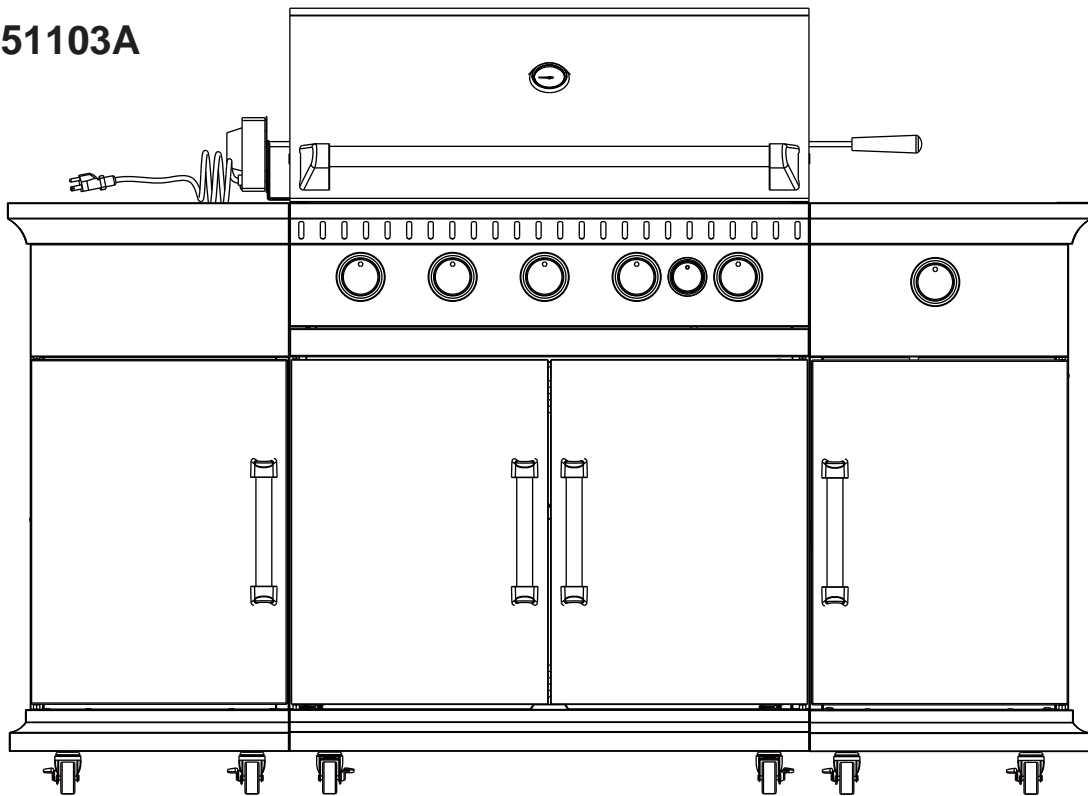

Step 1.1 - 1.2 - 1.3 - 1.4 - 2.1 - 2.2 - 2.3 - 2.4 - 5.1 - 5.2 - 5.3 - 6 - 7b - 8b - 10.1 - 10.2 - 11b - 12b

Assembly instructions

1.1

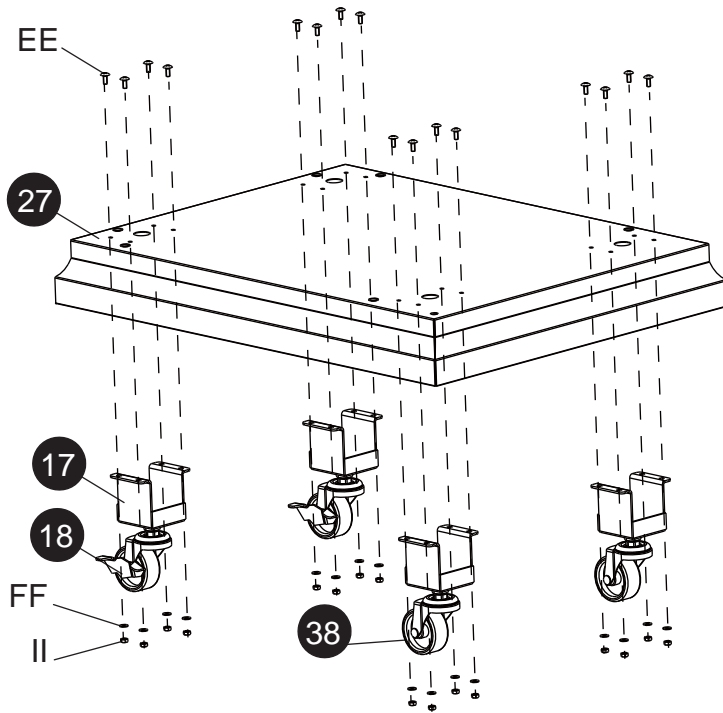

EE x 16 M4x10



FF x 16 D4



II x 16 M4



1.2

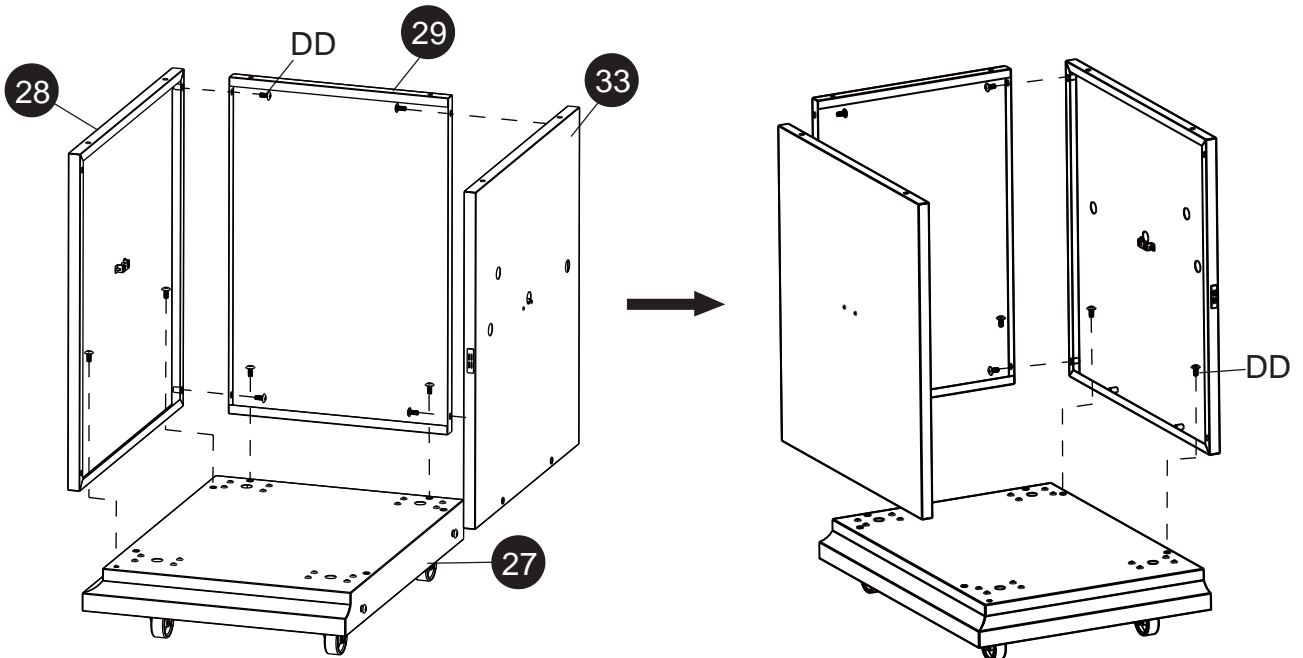

DD x 10 M6x14

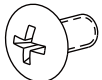

Assembly instructions

1.3

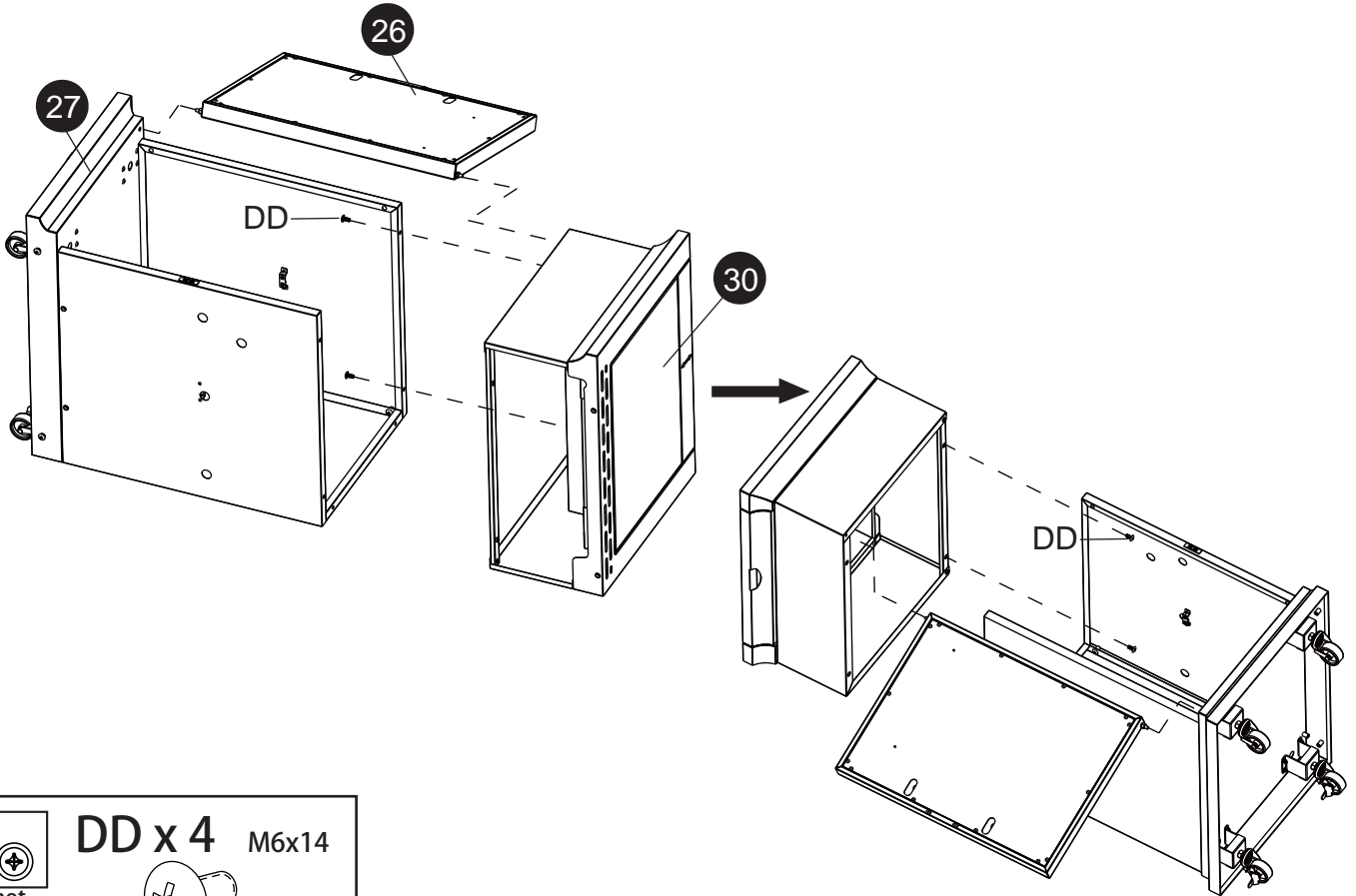

not supplied

DD x 4 M6x14

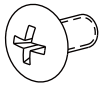

1.4

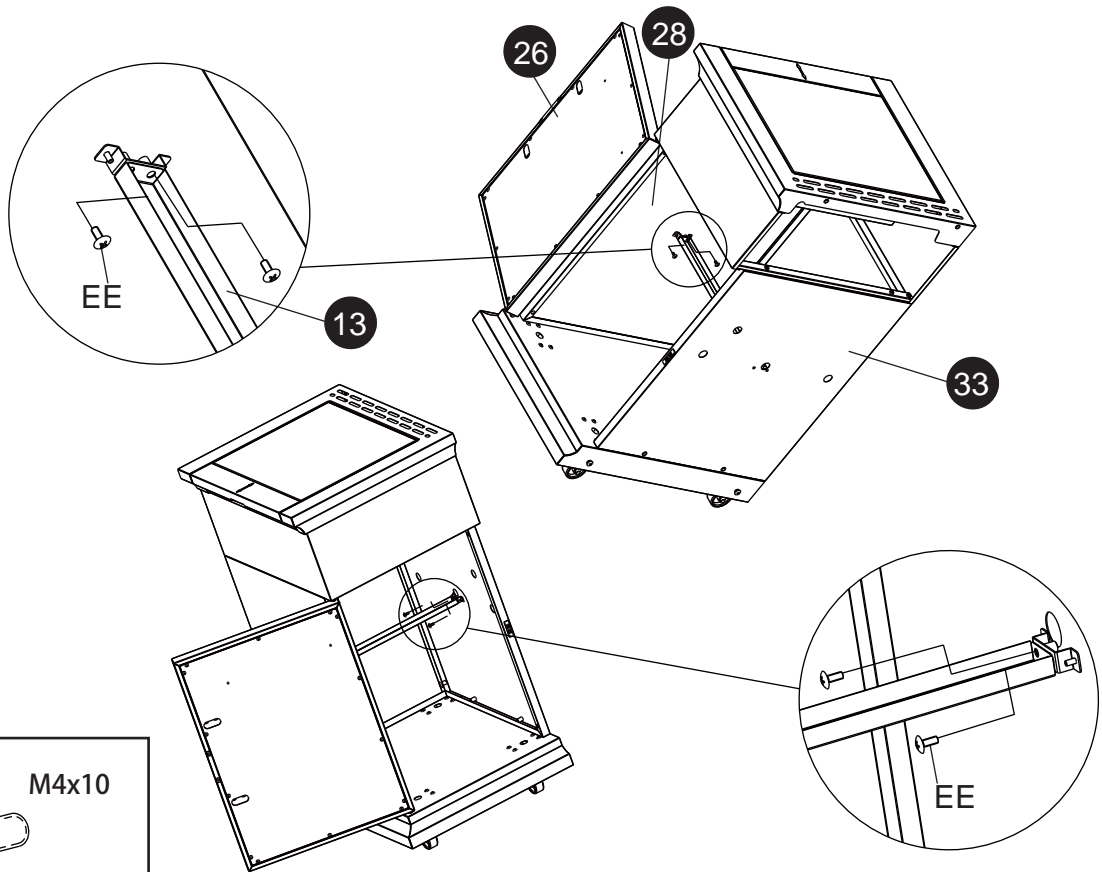

not supplied

EE x 4 M4x10

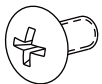

Assembly instructions

2.1

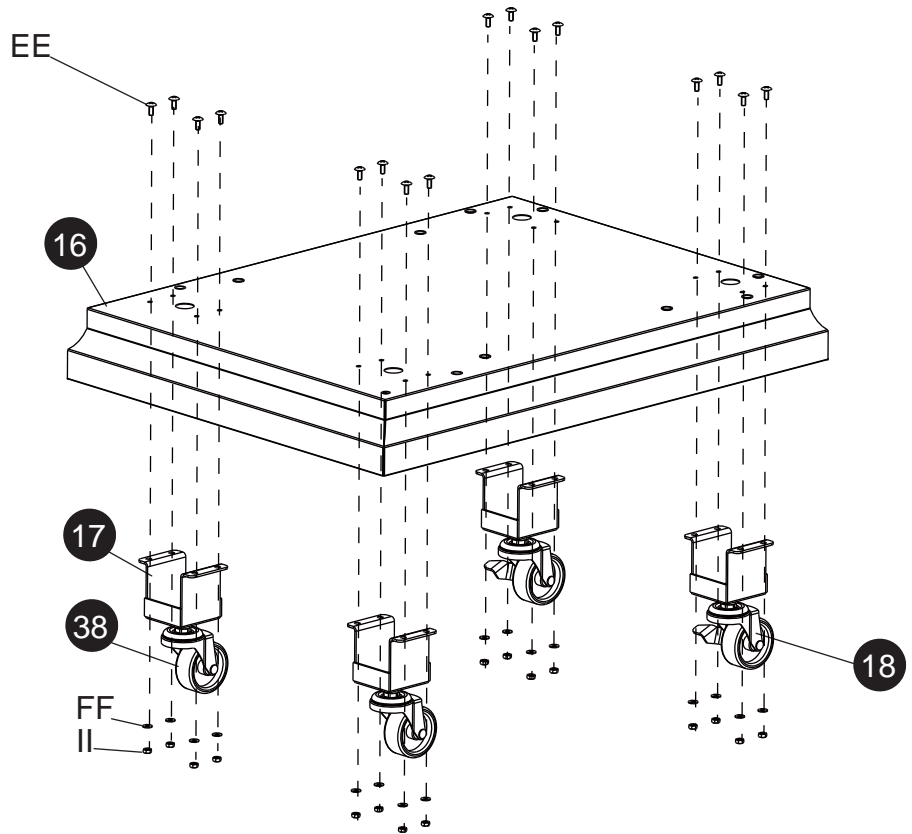

EE x 16 M4x10



FF x 16 D4



II x 16 M4



2.2

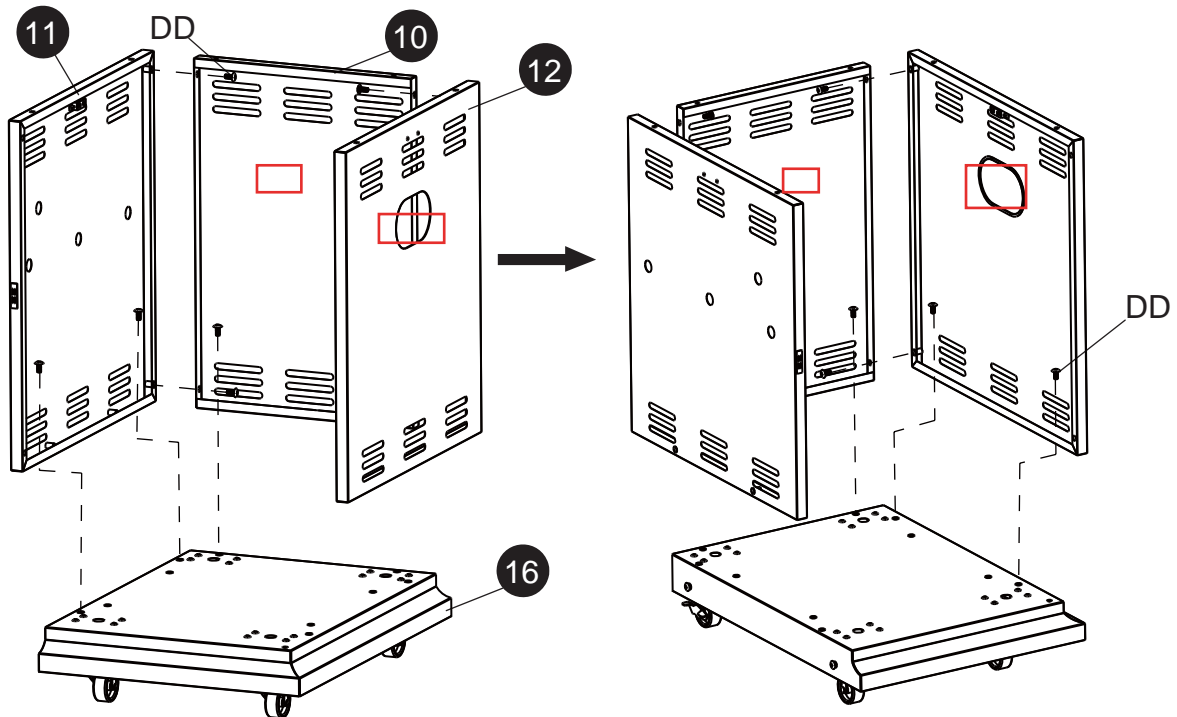

DD x 10 M6x14

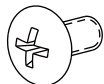

Assembly instructions

2.3

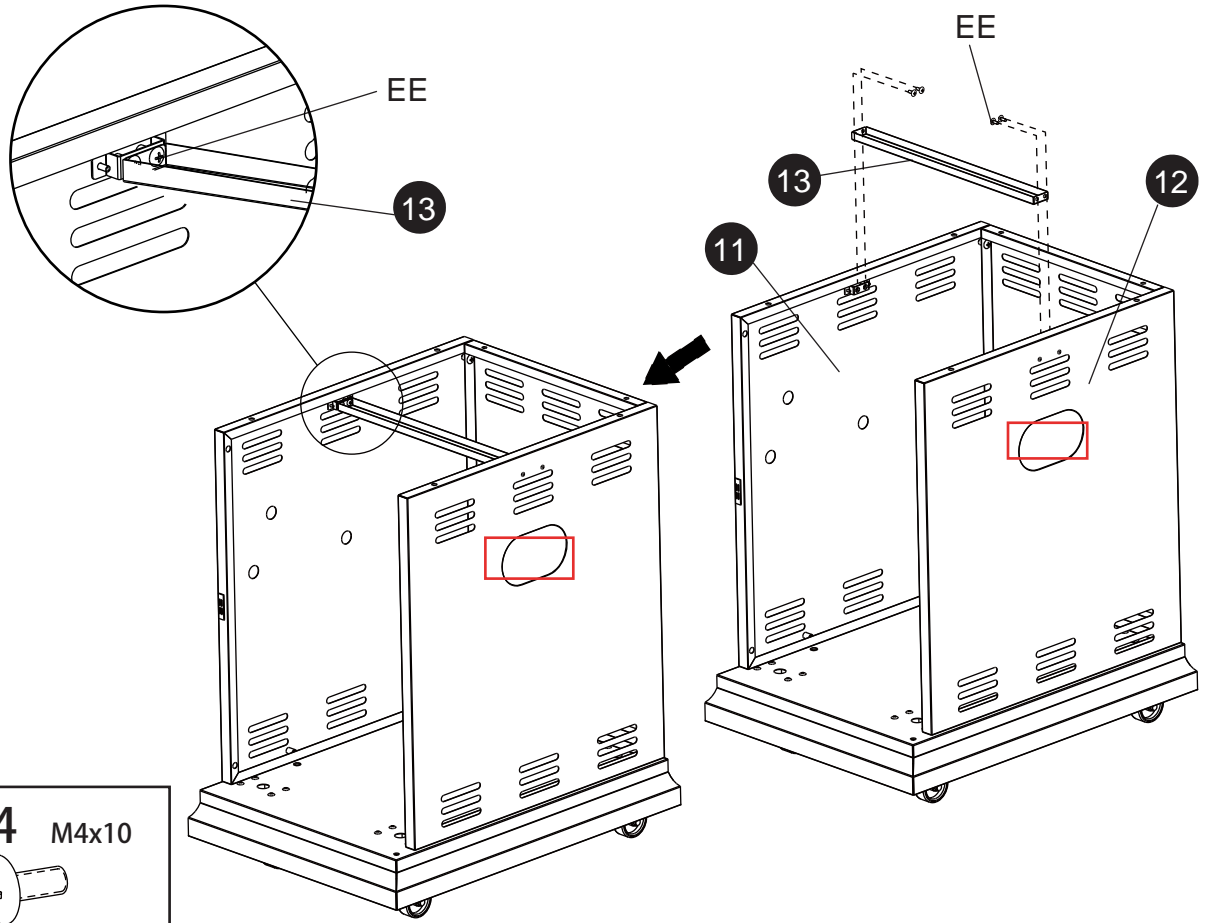

EE x 4 M4x10



2.4

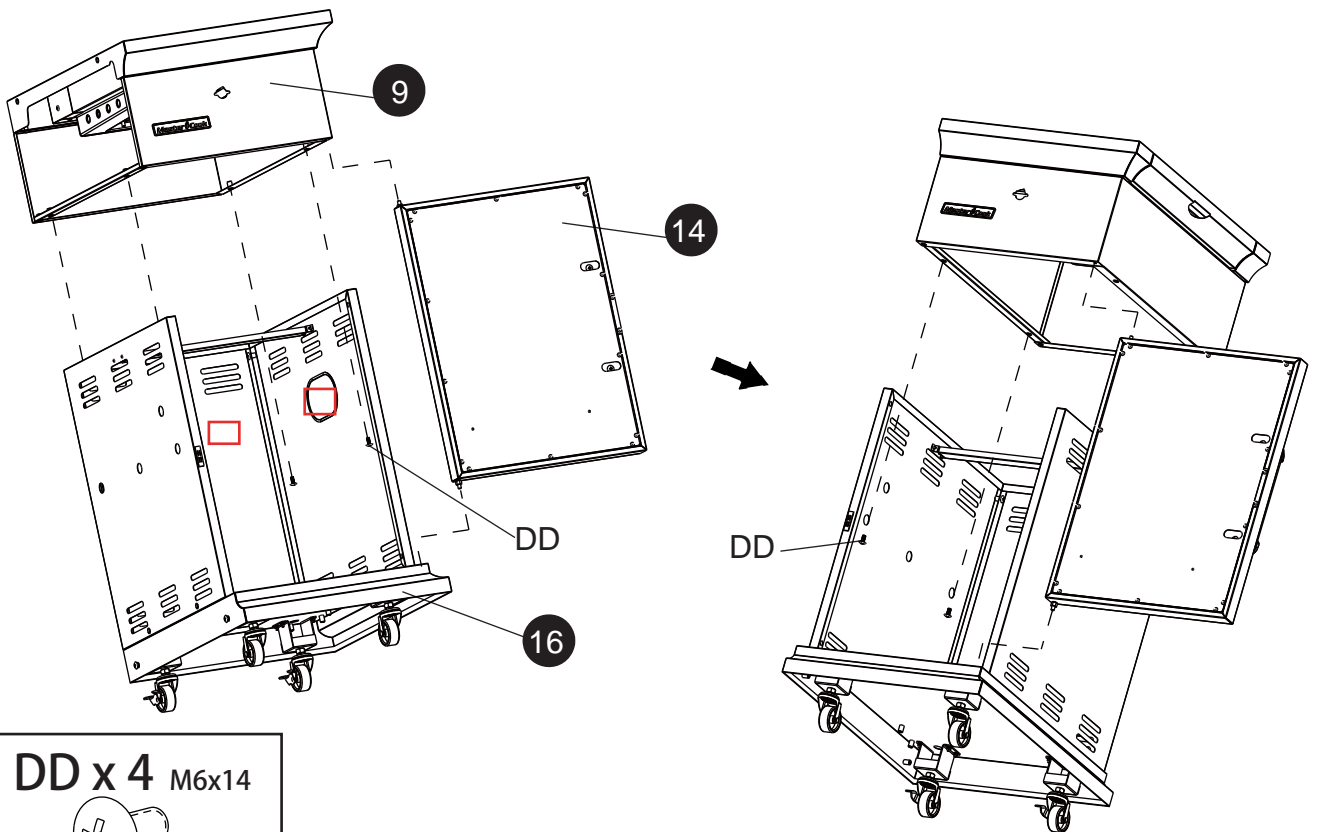

DD x 4 M6x14

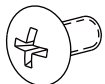

Assembly instructions

3.1

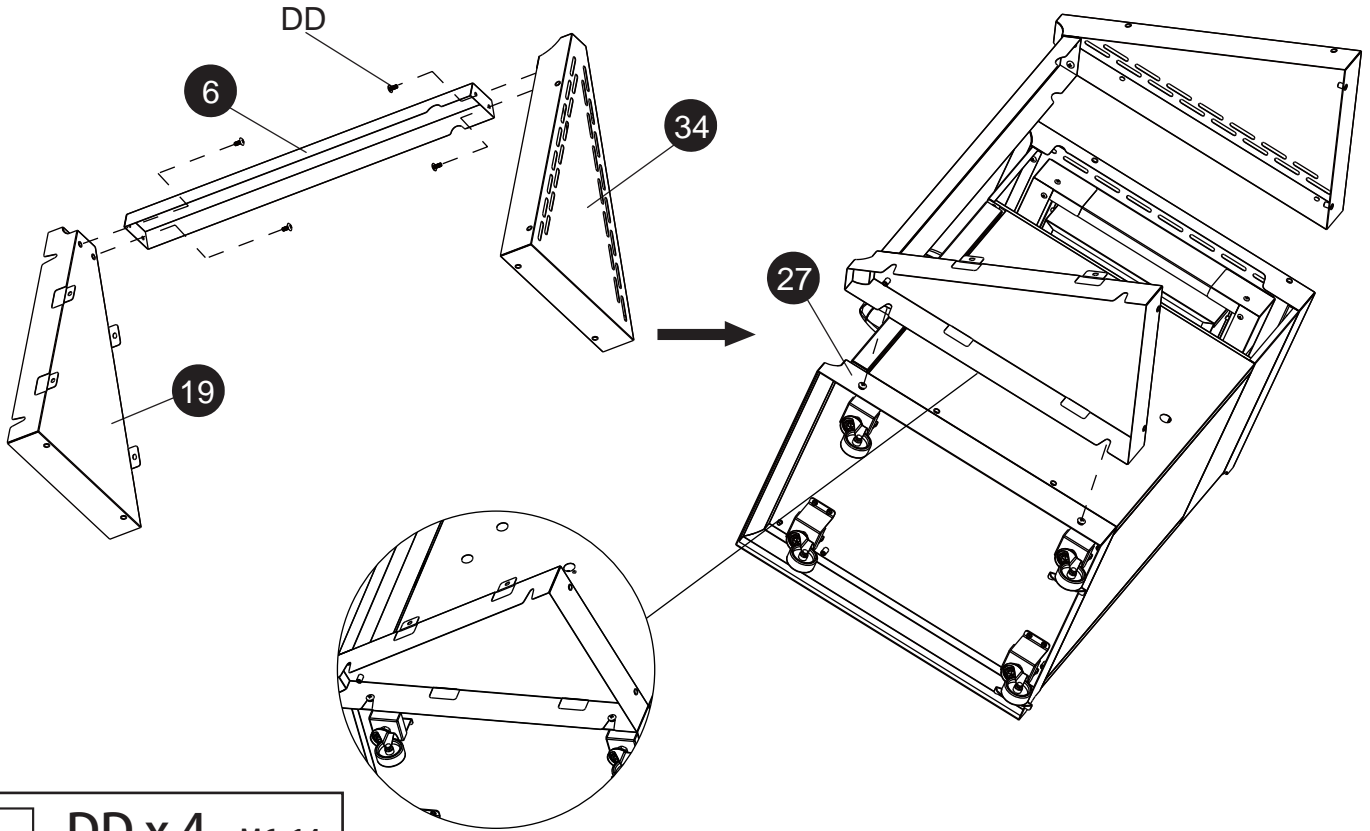

DD x 4 M6x14

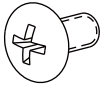

3.2

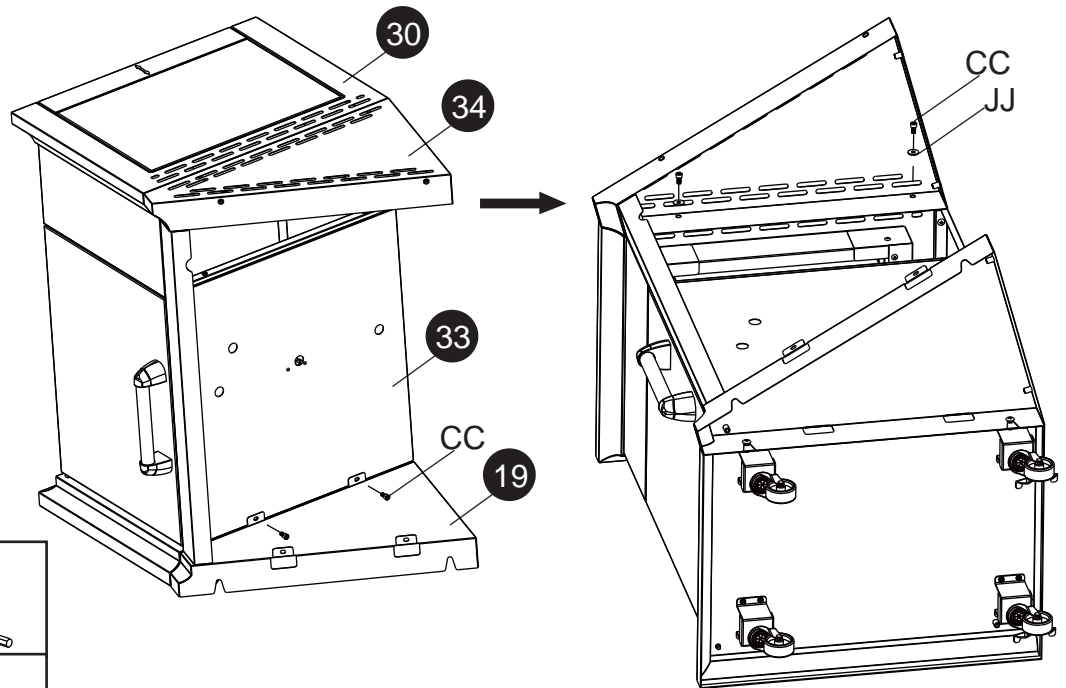

BB x 1

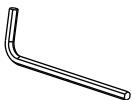

CC x 4
M6x12

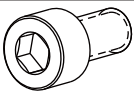

JJ x 2
6 x 18 mm



Assembly instructions

4.1

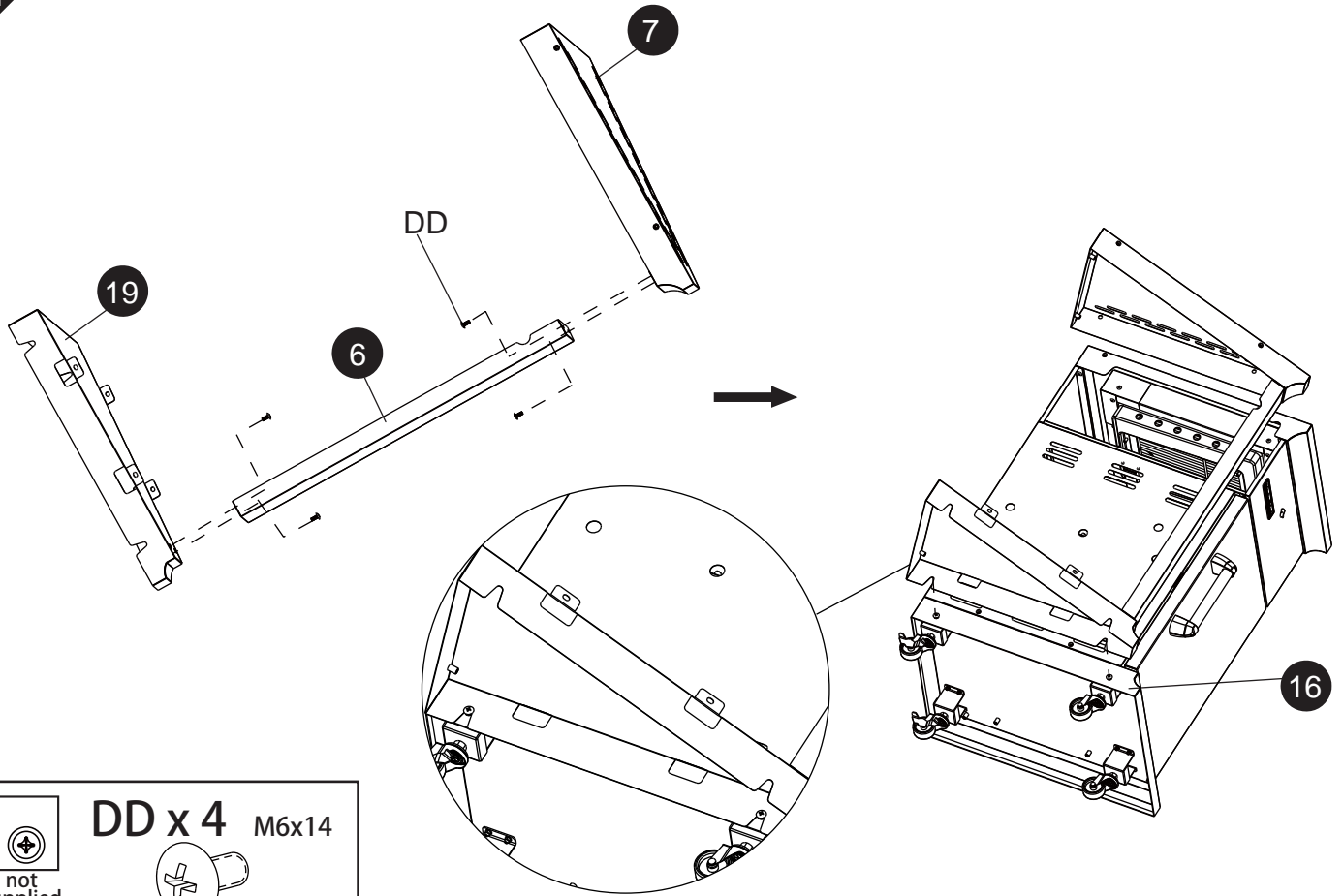

DD x 4 M6x14

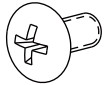

4.2

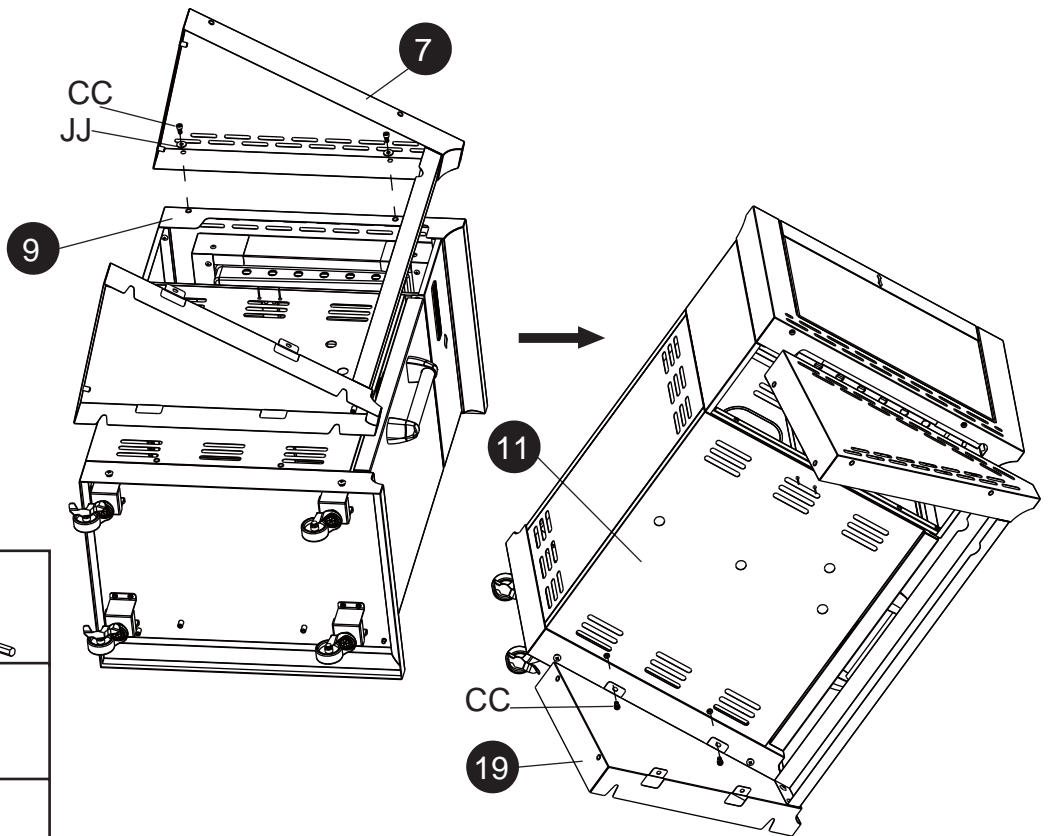

BB x 1

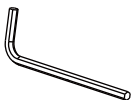

CC x 4
M6x12

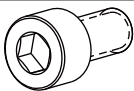

JJ x 2
6 x 18 mm



Assembly instructions

5.1

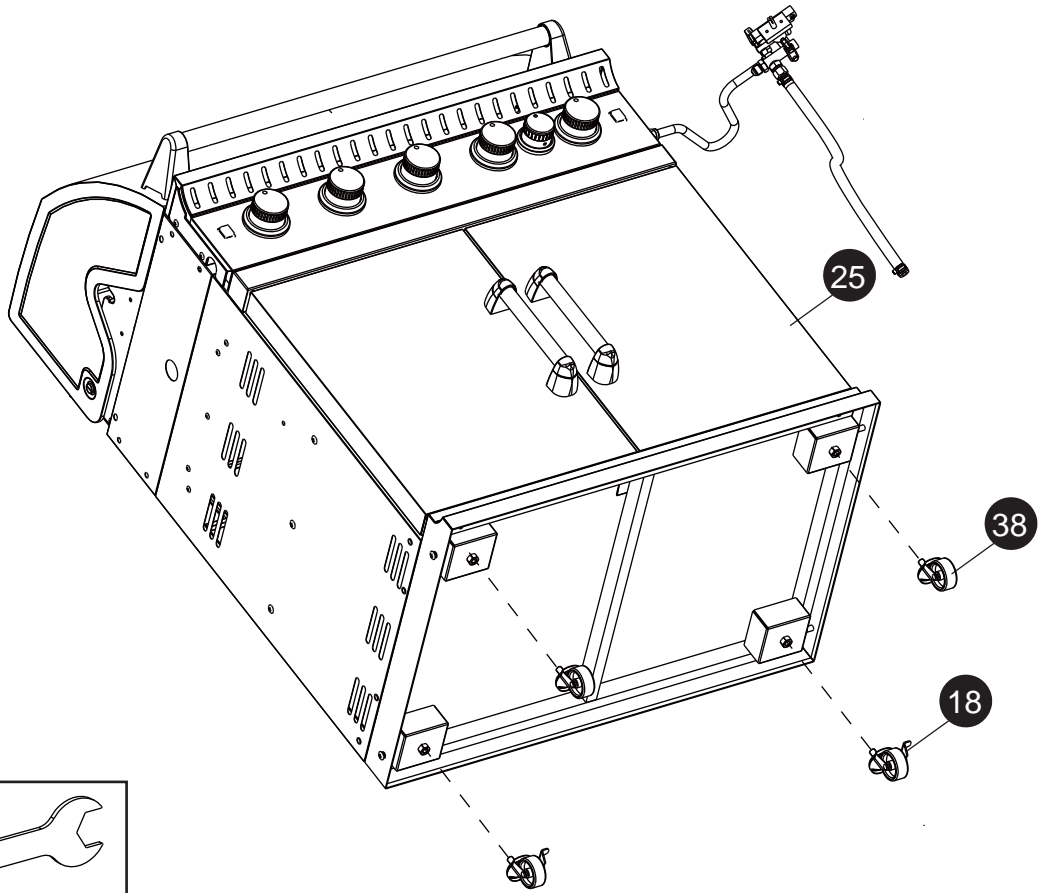

KK x 1

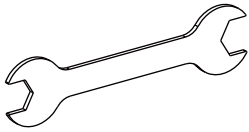

5.2

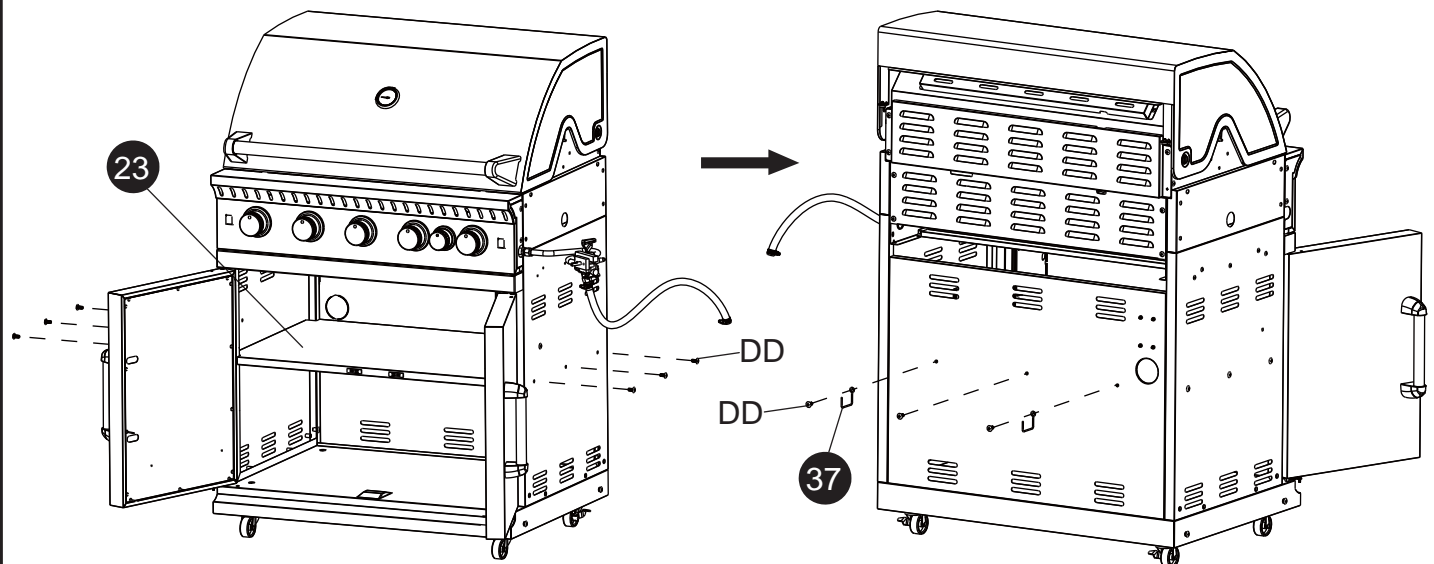

not
supplied

DD x 9 M6x14



Assembly instructions

5.3

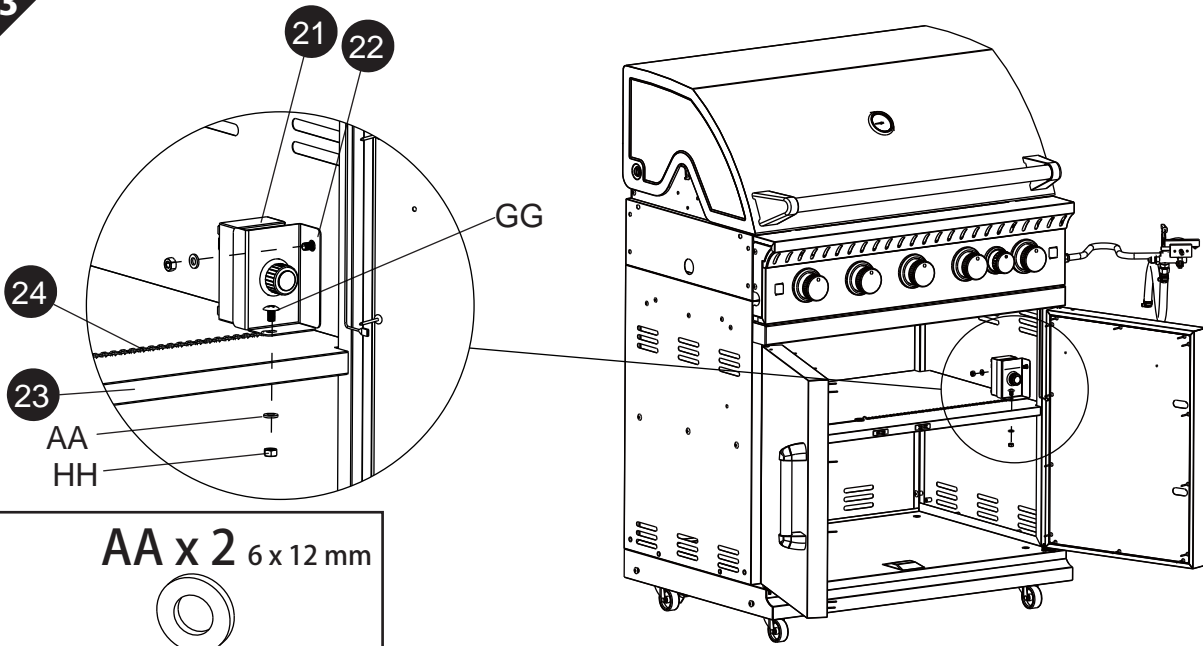

AA x 2 6 x 12 mm



not supplied

GG x 2 M6x10



not supplied

HH x 2 M6



44

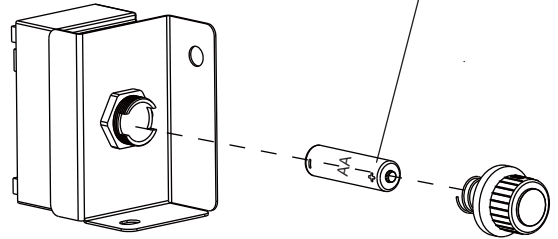

6

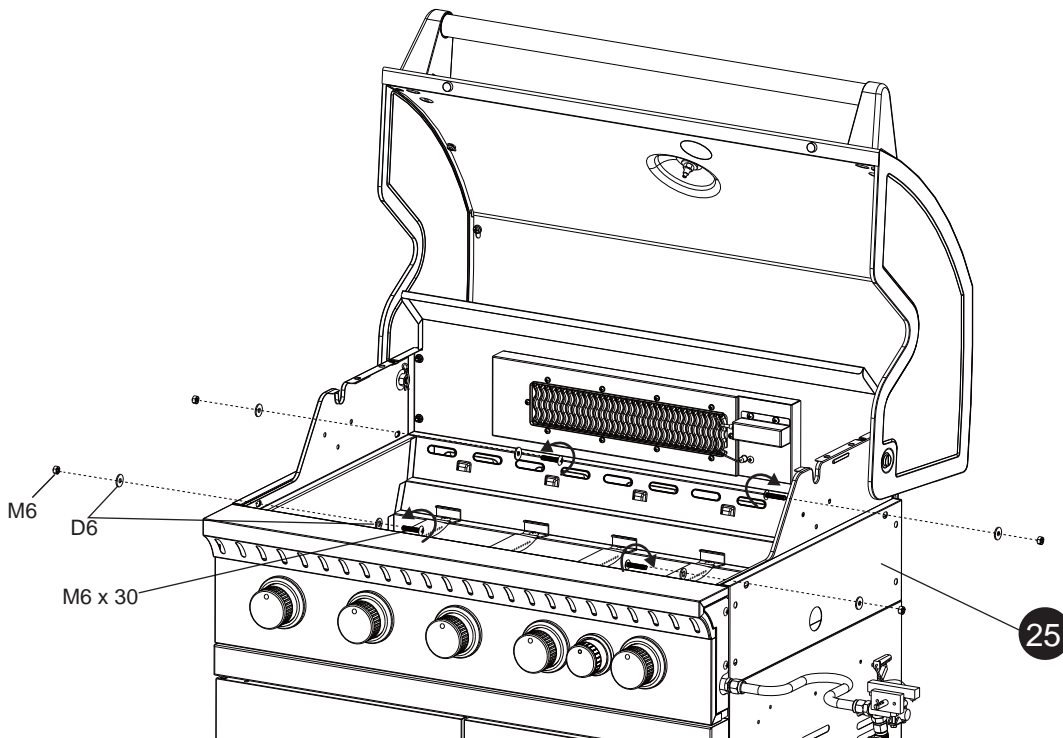

not supplied



not supplied

M6

D6

M6 x 30

25

Assembly instructions

7a

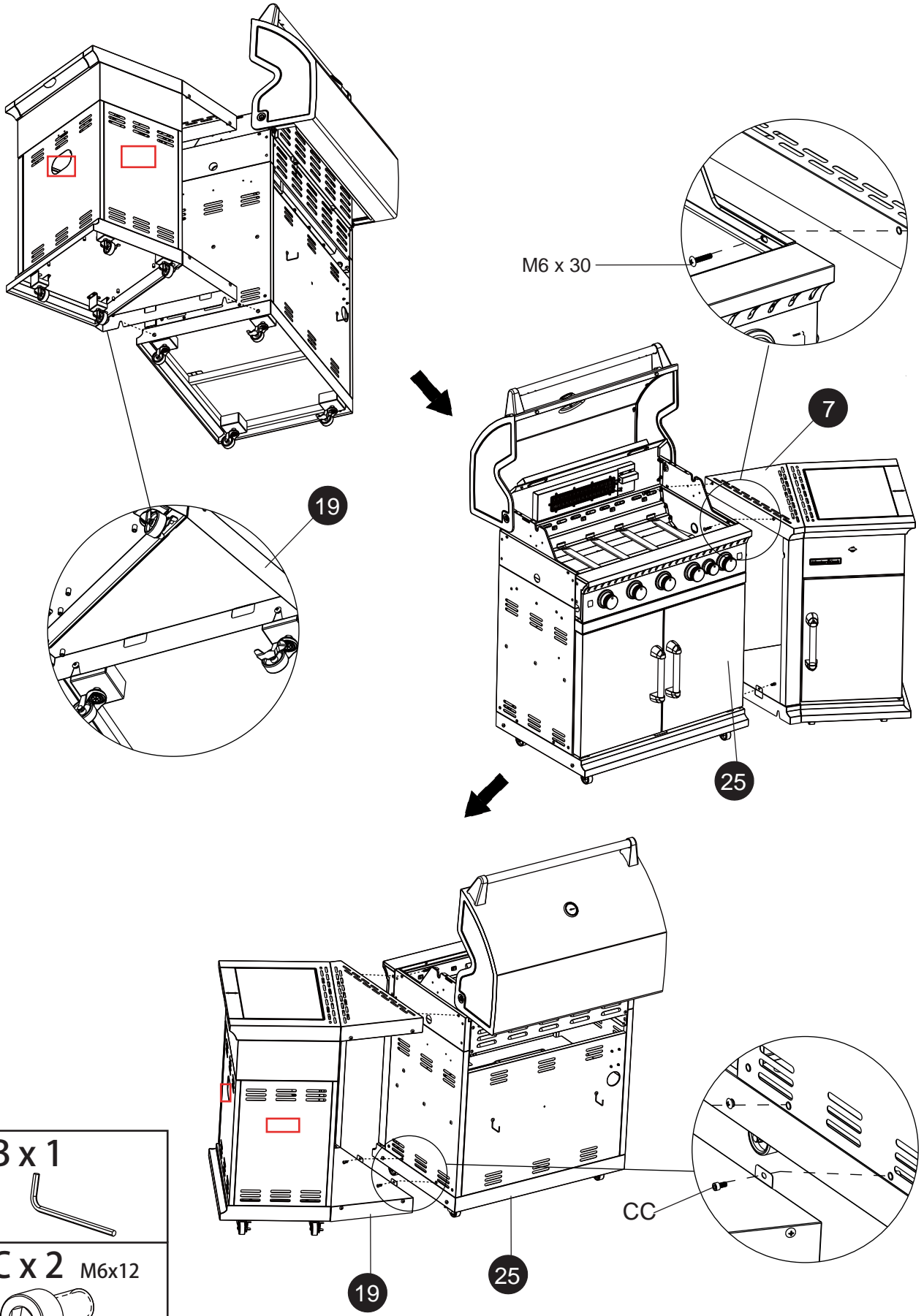

Assembly instructions

7b

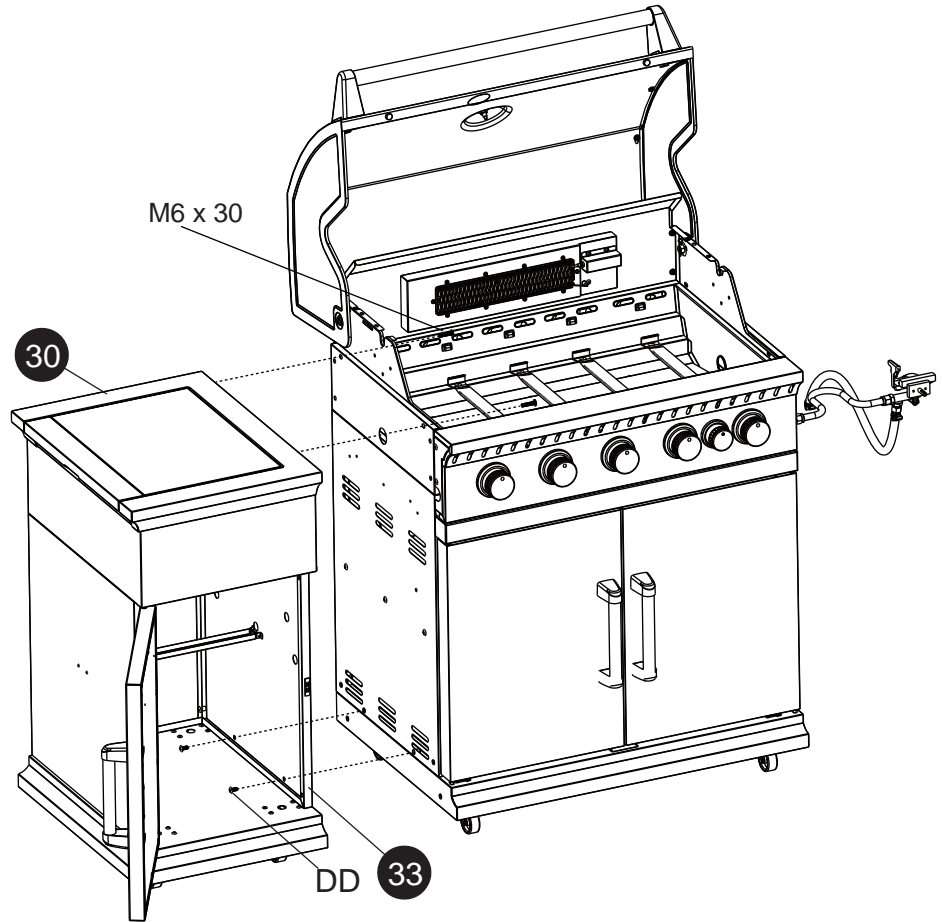

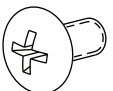

DD x 2 M6 x 14
 not supplied

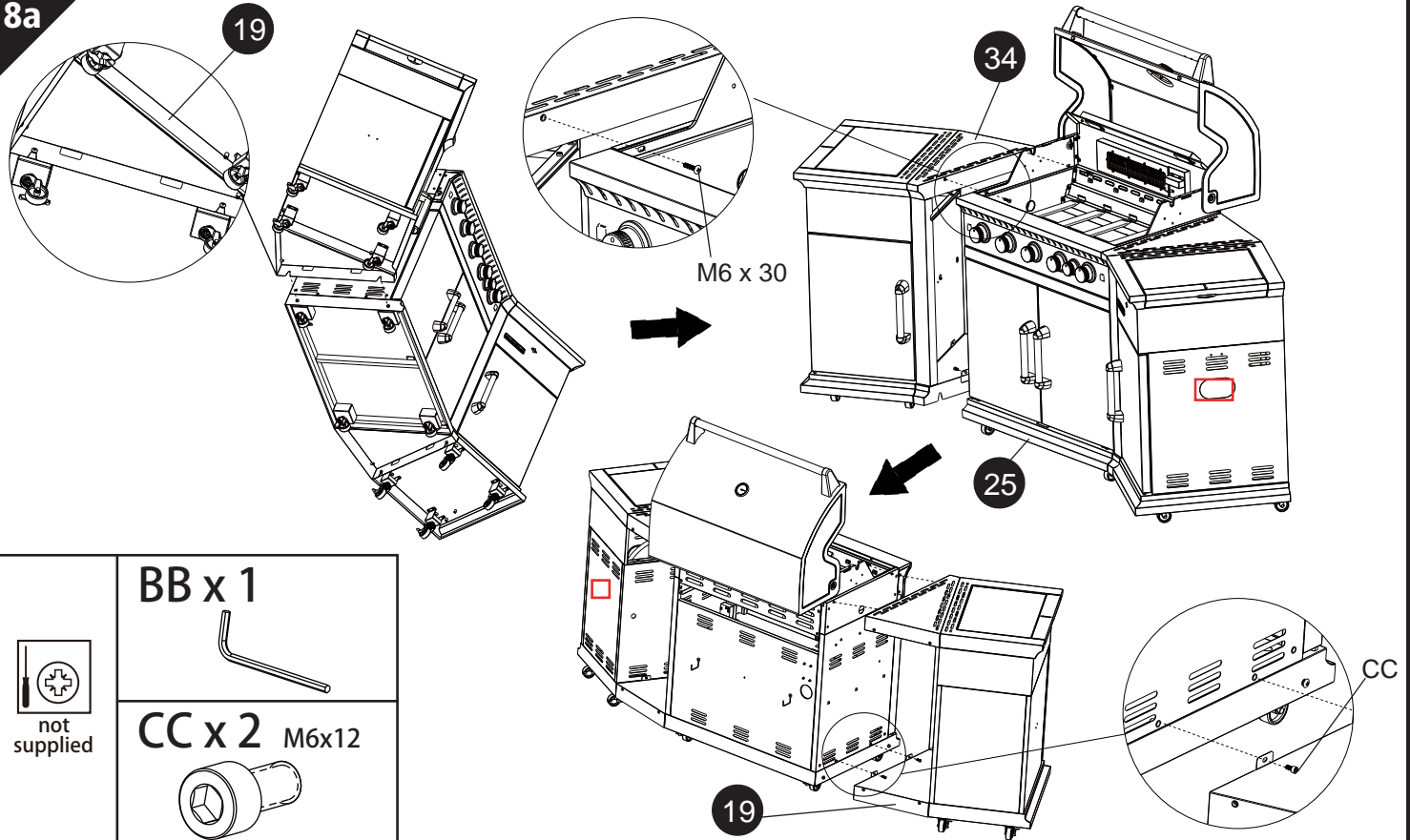
8a

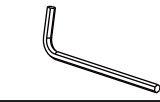

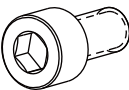

BB x 1
 not supplied

CC x 2 M6x12

Assembly instructions

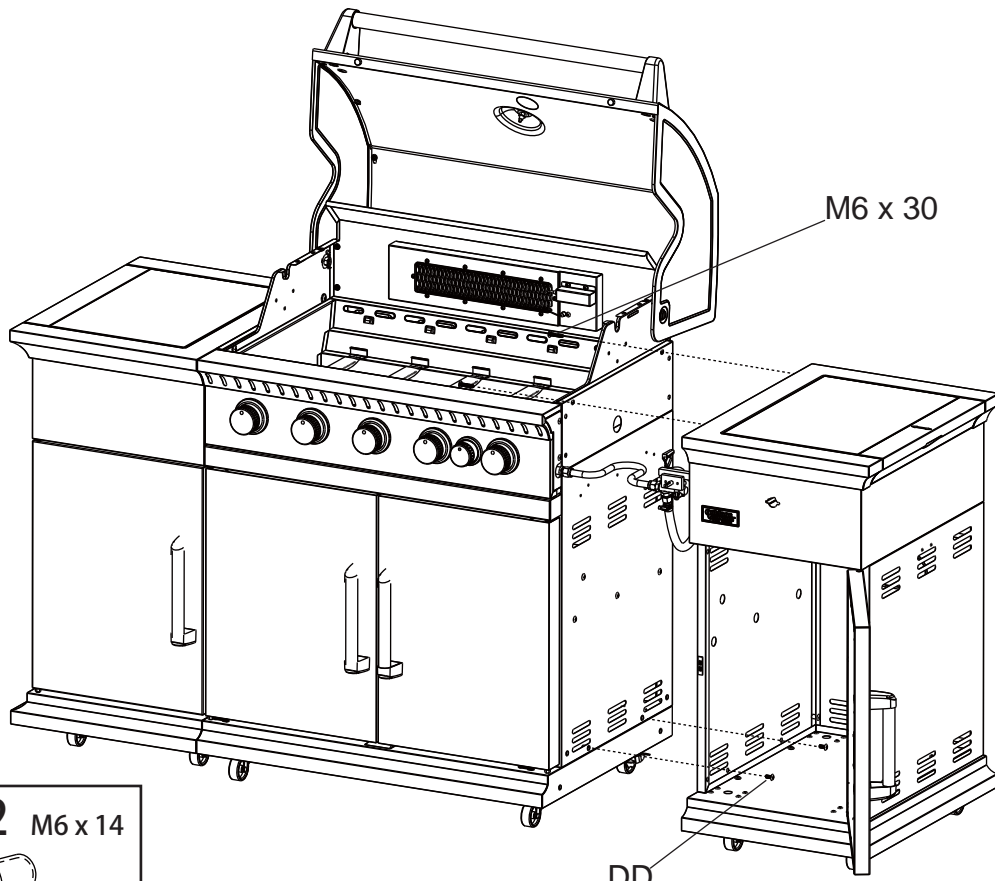
8b



not supplied

DD x 2 M6 x 14

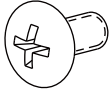

9

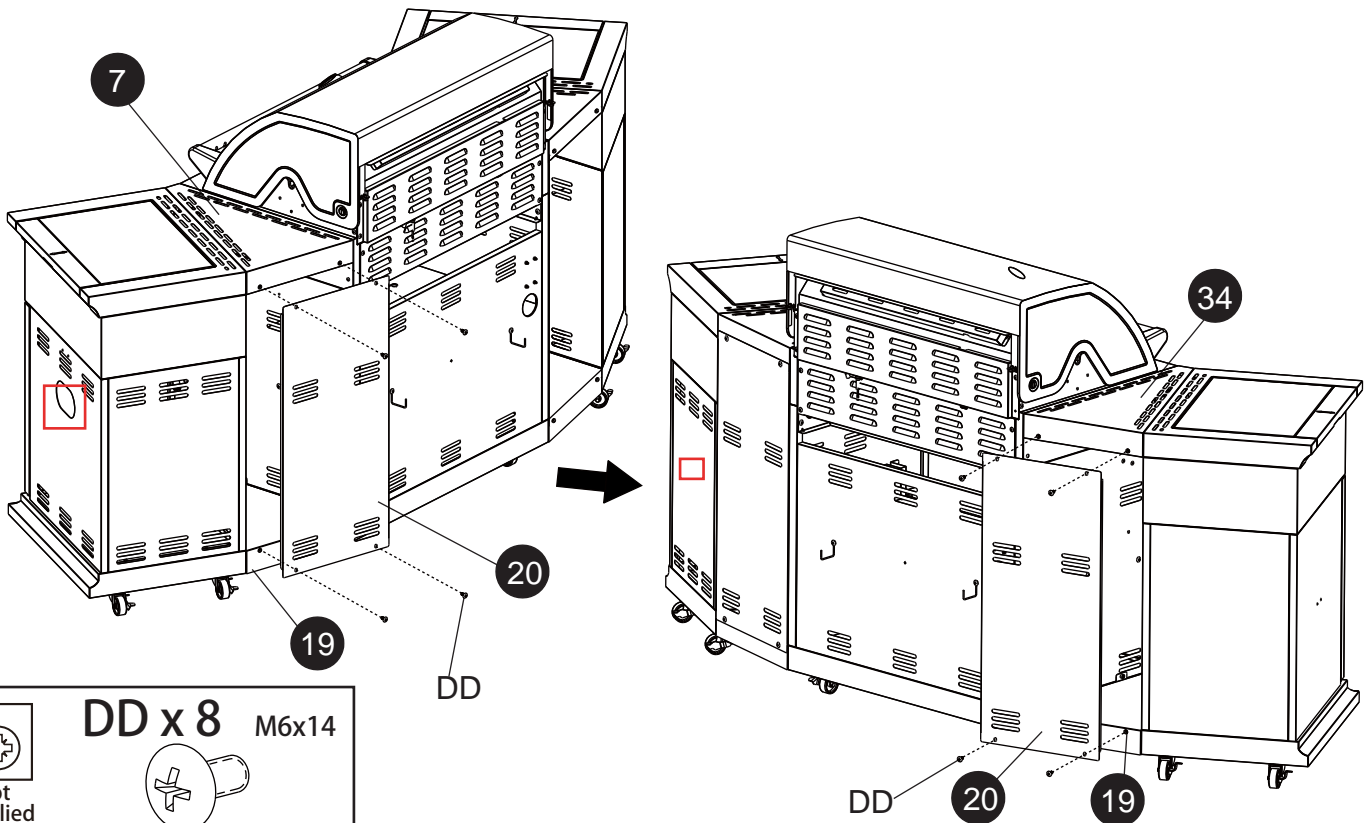

not supplied

DD x 8 M6x14

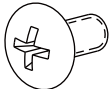

Assembly instructions

10.1

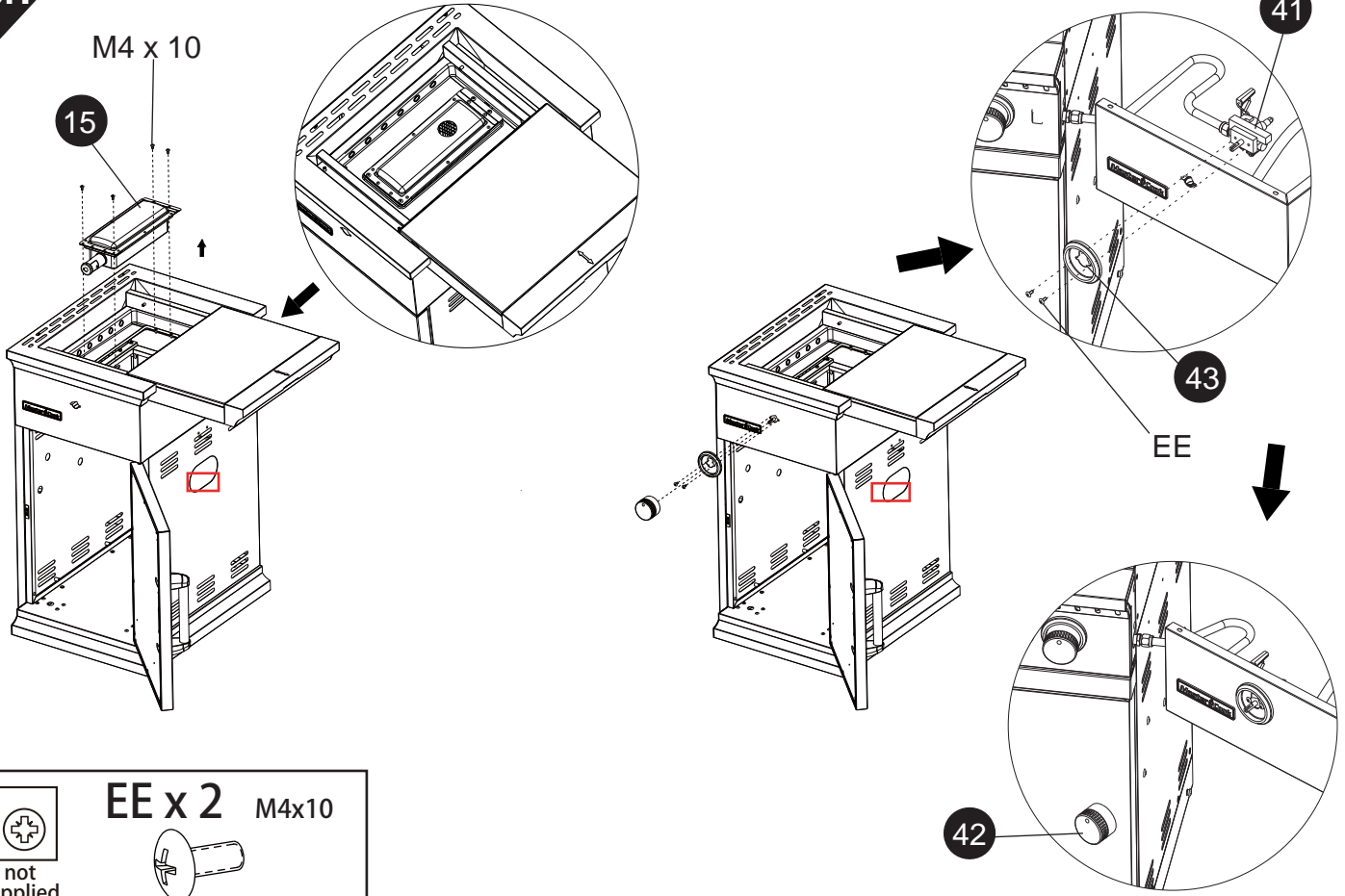

10.2

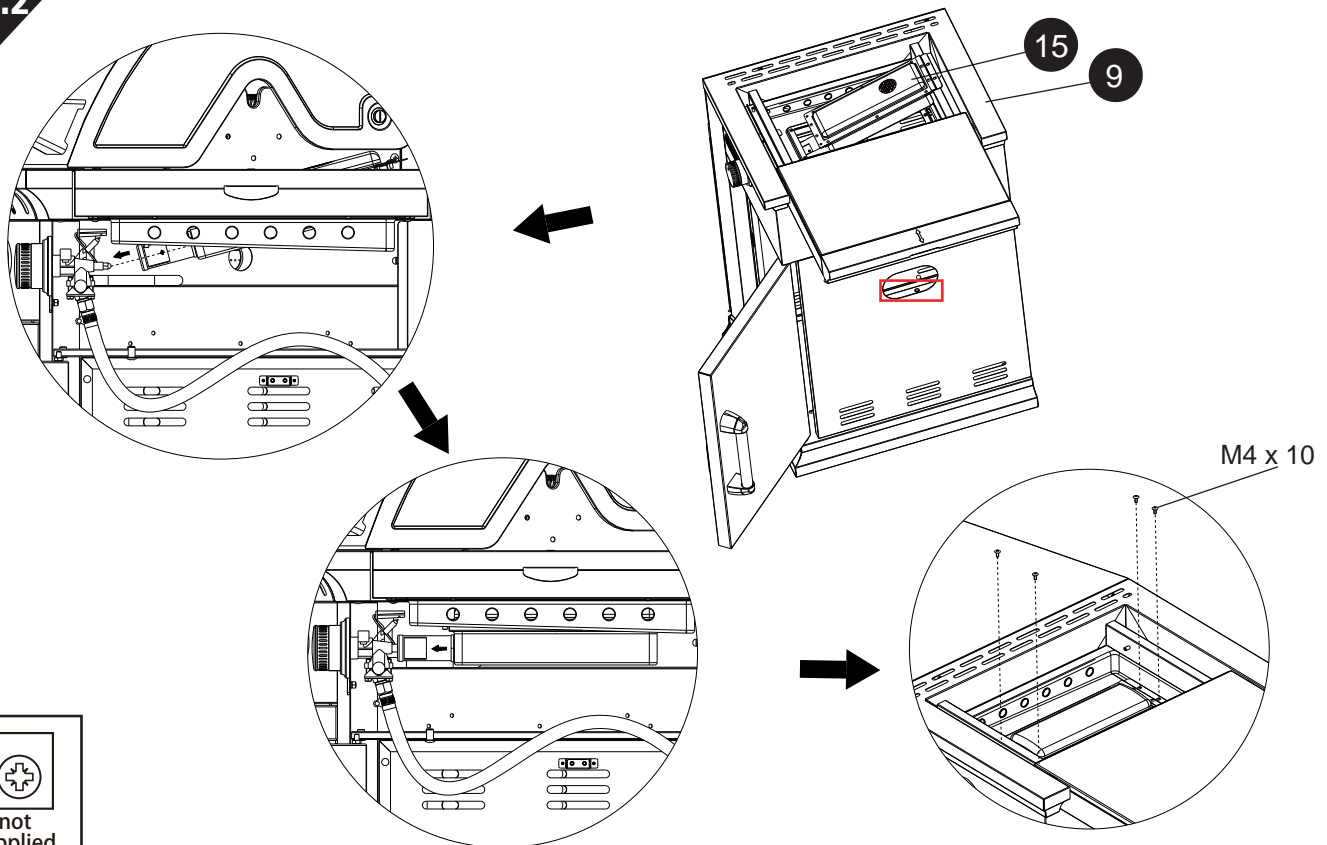

Assembly instructions

11a

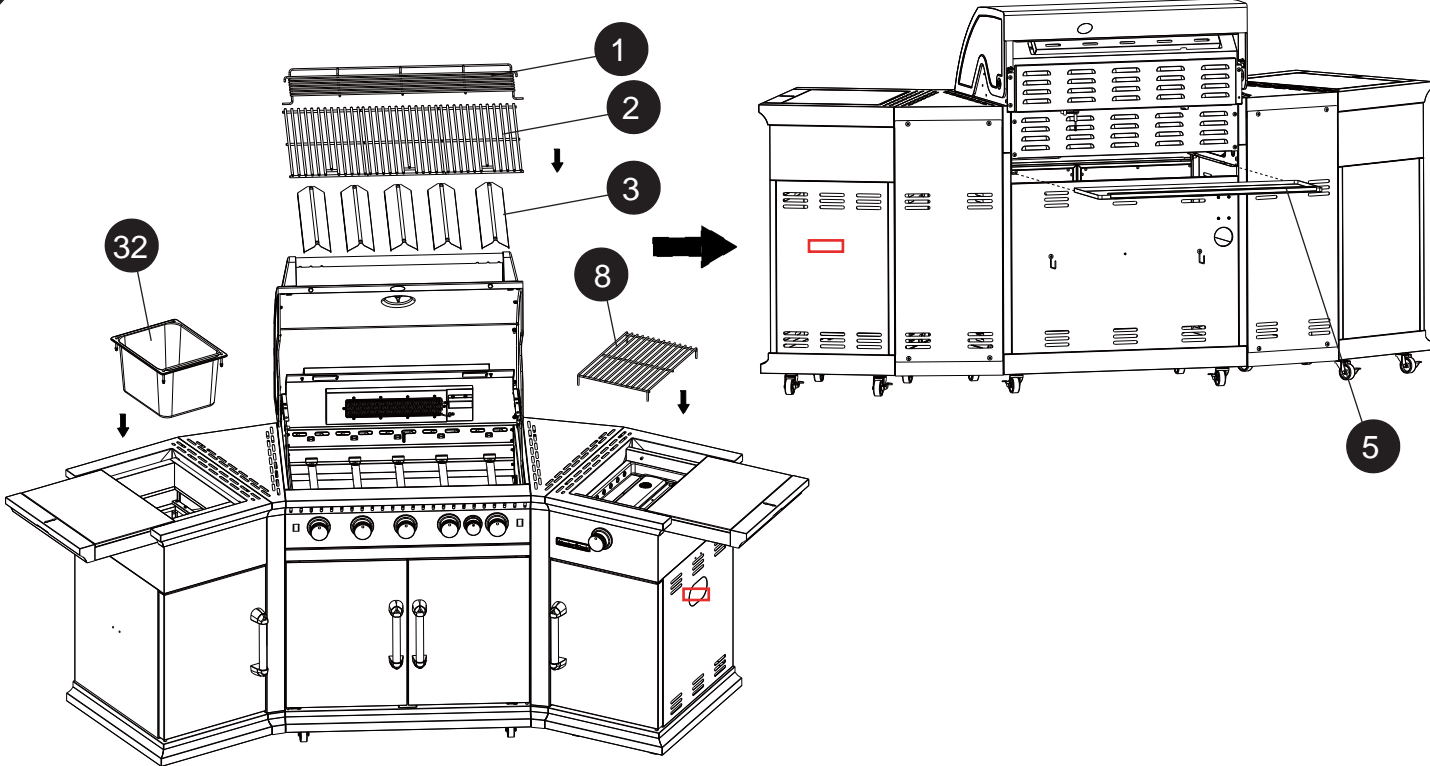

11b

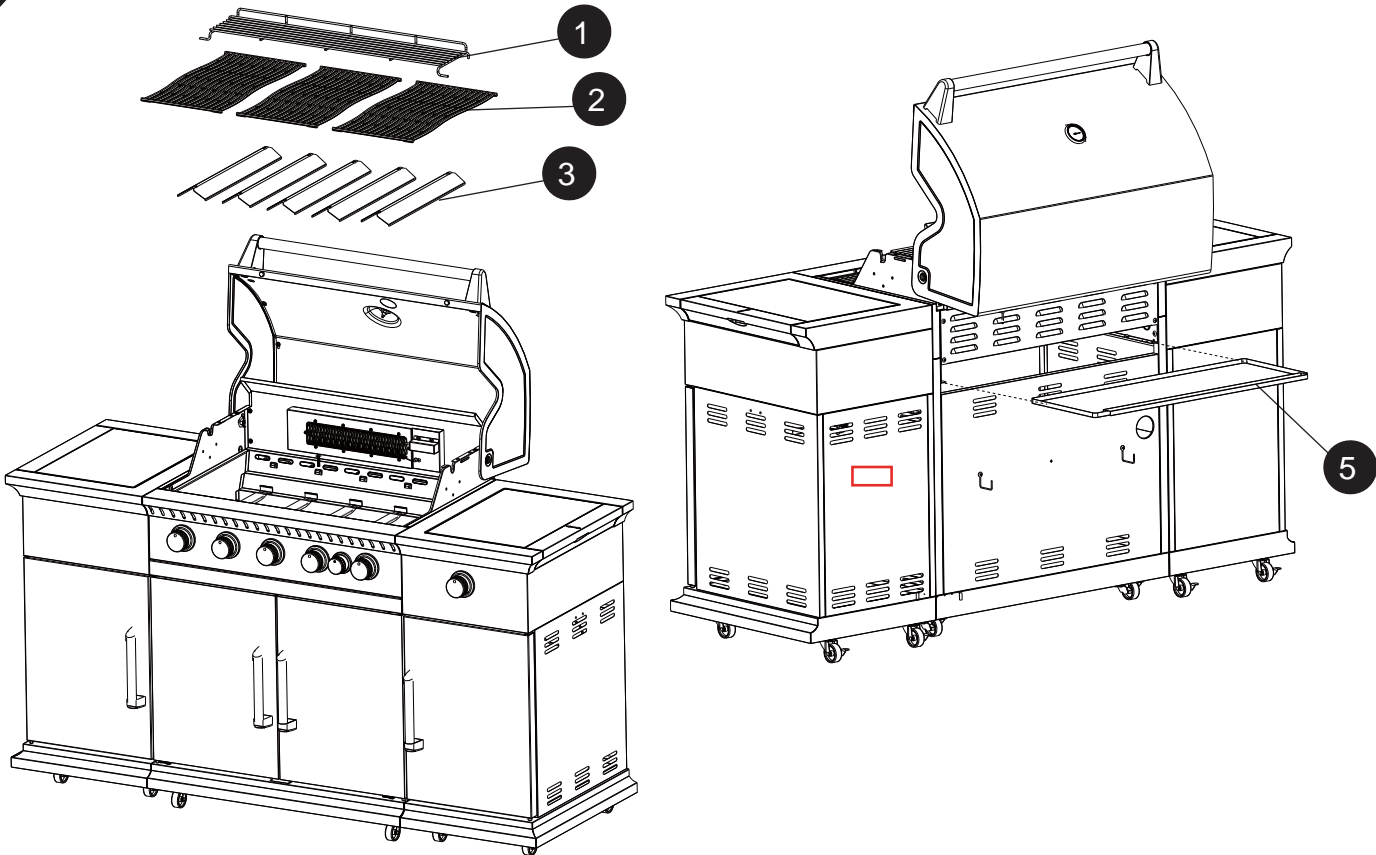

Assembly instructions

12a

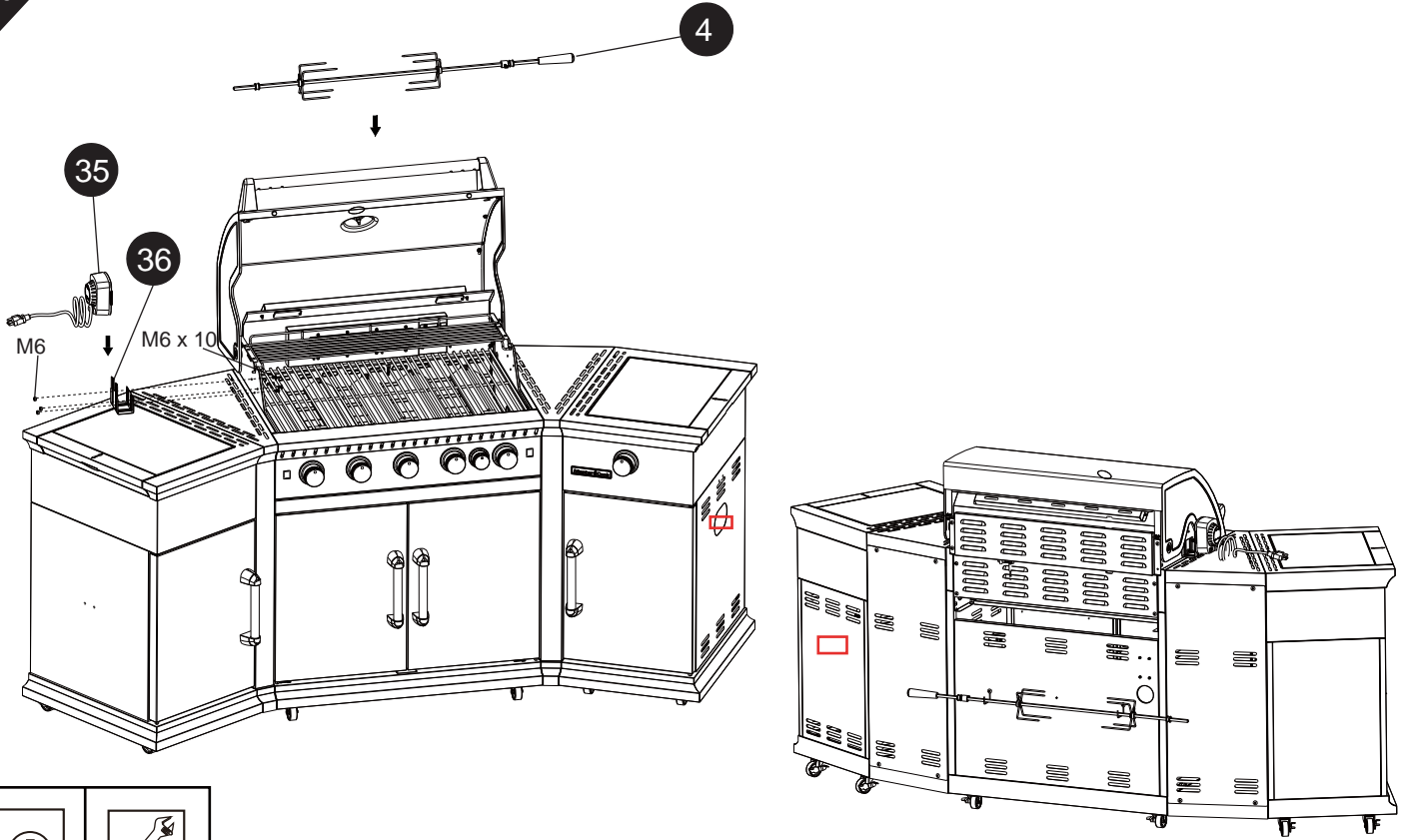

12b

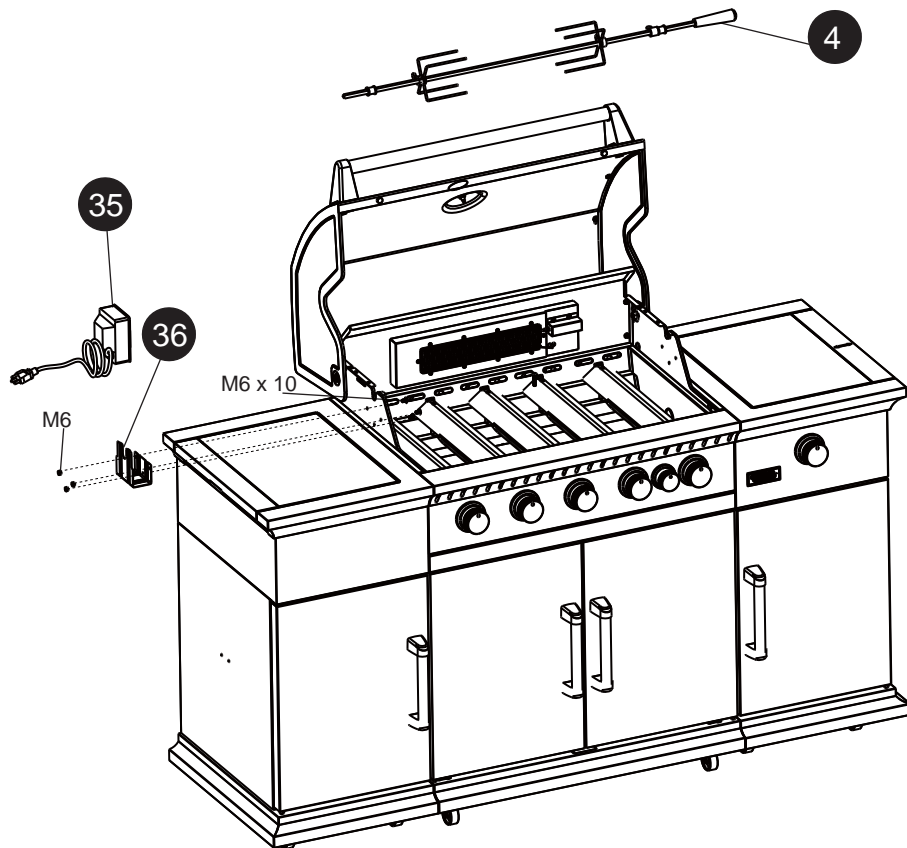

LIGHT SWITCH WIRE CONNECTING LAYOUT

Attach the transformer and grounding wire to the cart rear panel with four M4x10 screws and M4 nuts.

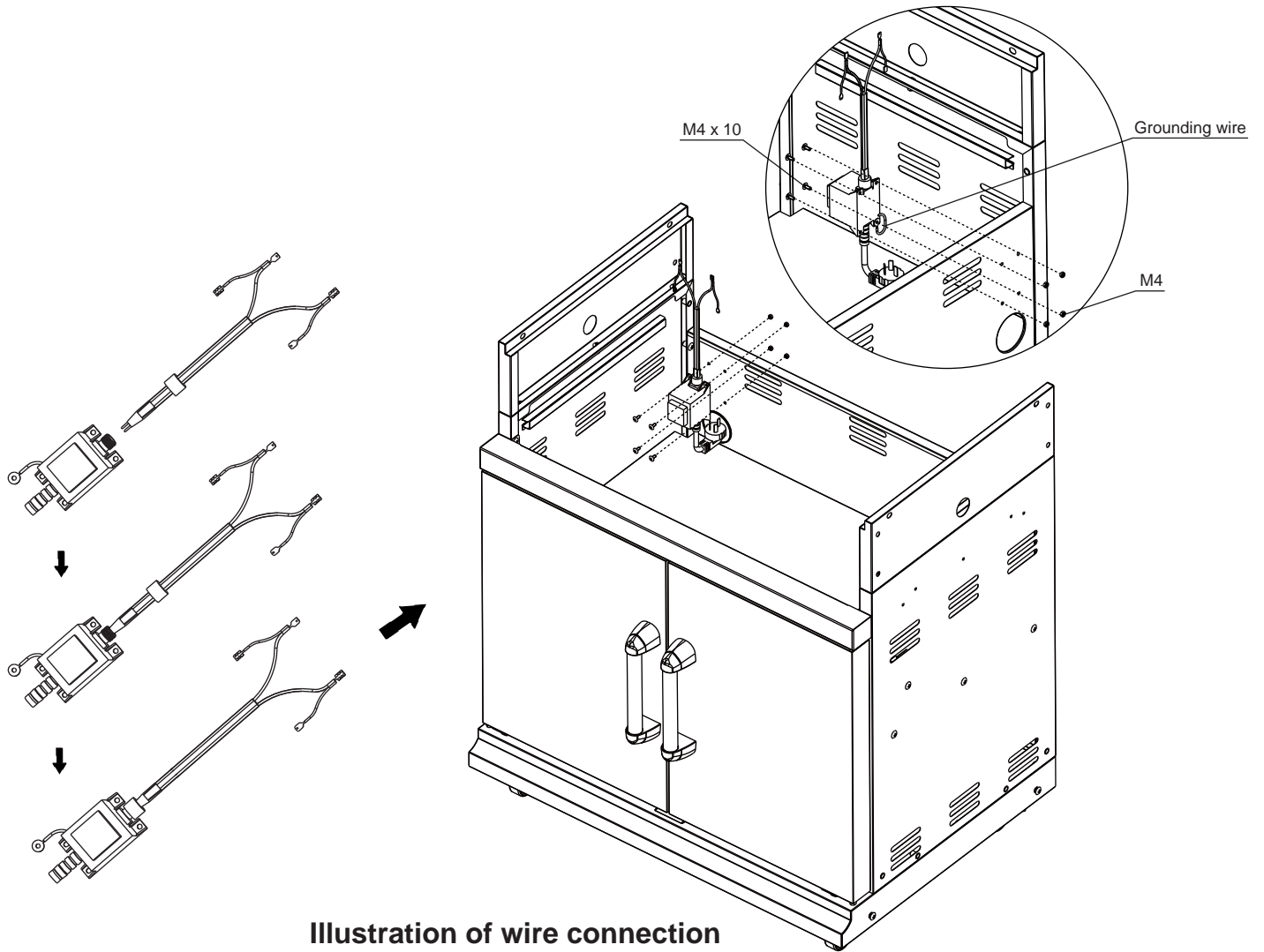
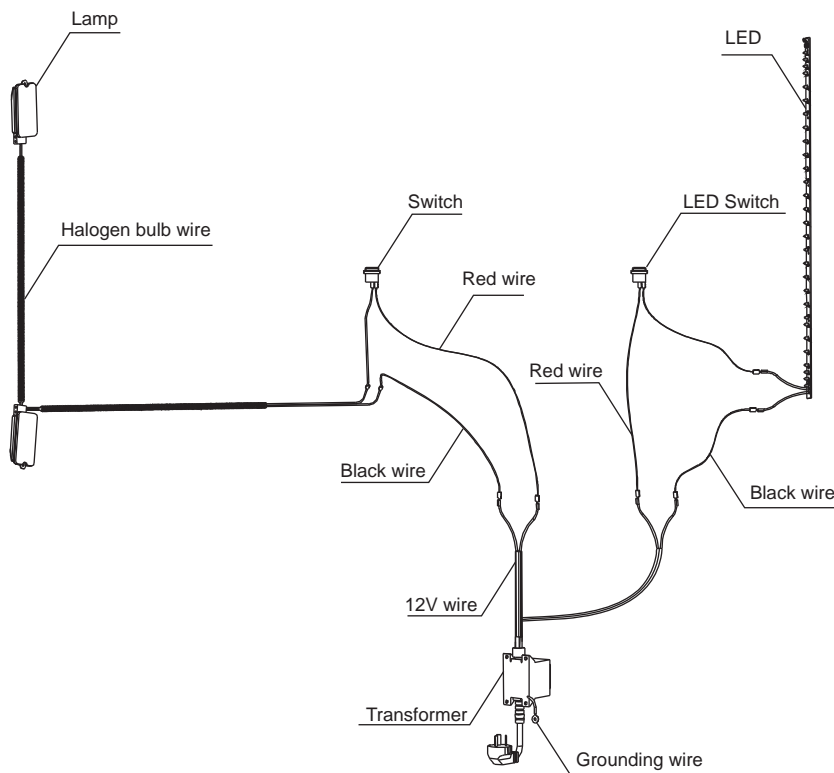
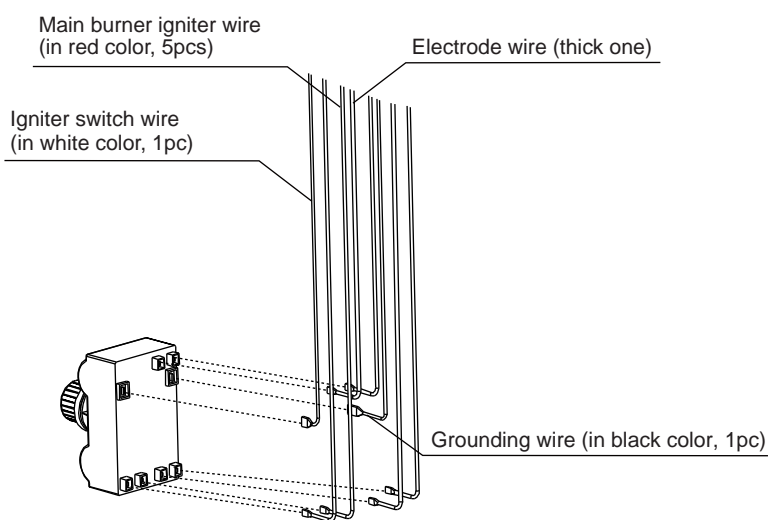
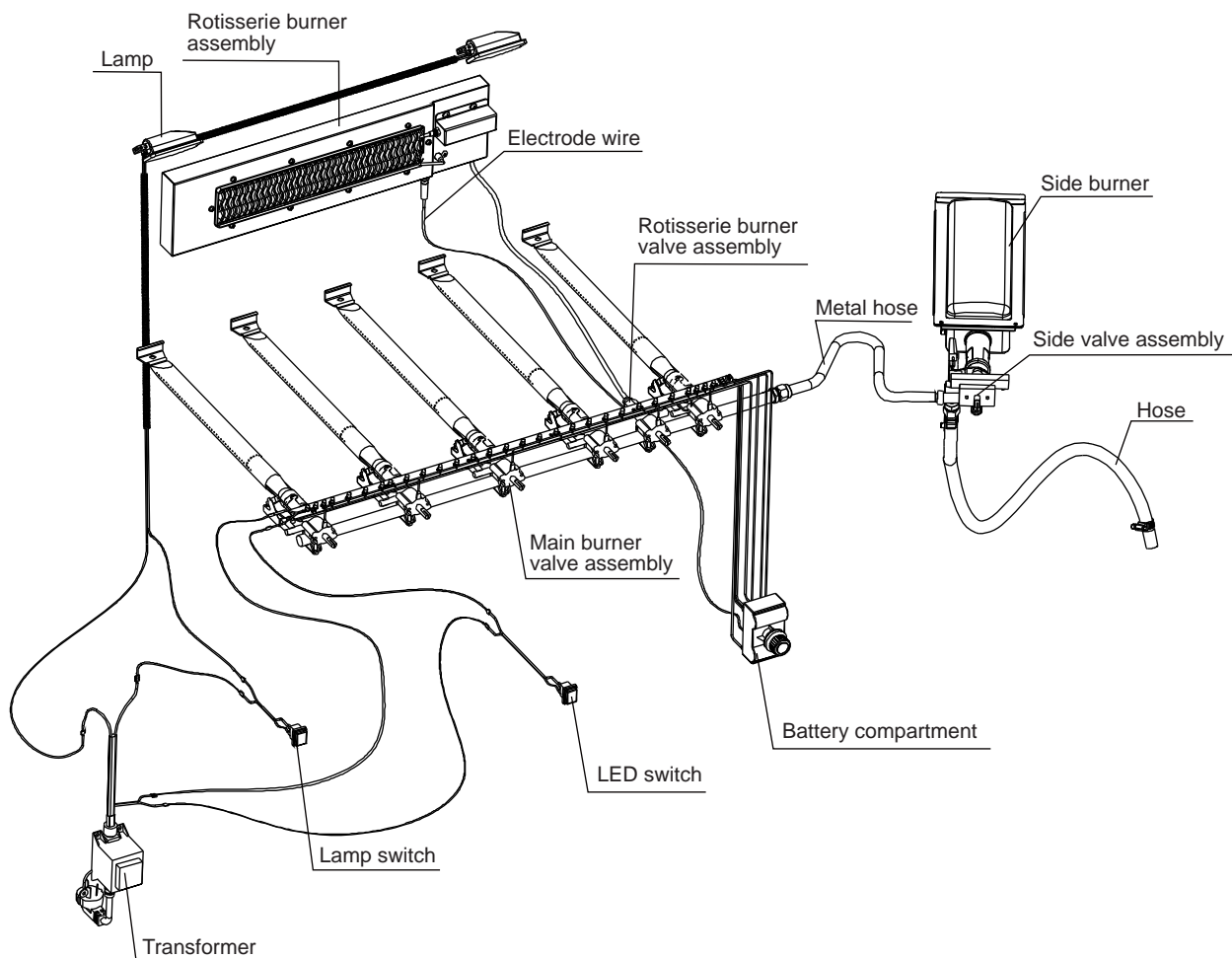

Illustration of wire connection



BURNER SYSTEM ILLUSTRATION WIRE CONNECTING SYSTEM LAYOUT



Note: The grounding wire and igniter switch wire must be inserted into the positions as figure shown. The other wires can be inserted into any other positions.