

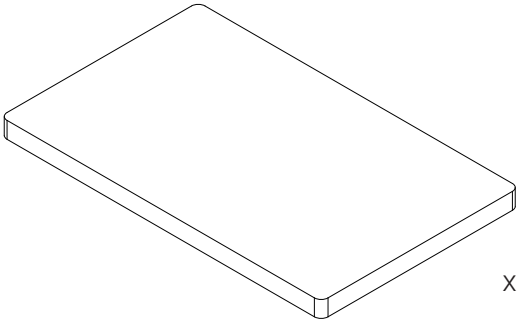

FORESSO[®]
THE TIMBER TERRAZZO
MADE IN BRITAIN

Trestle Stool Instruction Manual



x 1

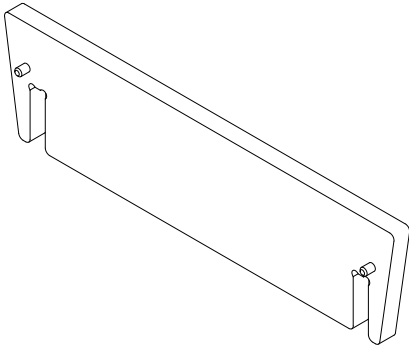

x 1

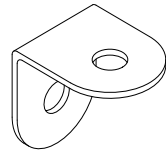

x 4

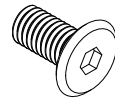

x 8

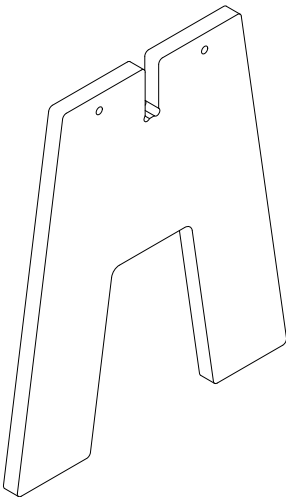

x 2

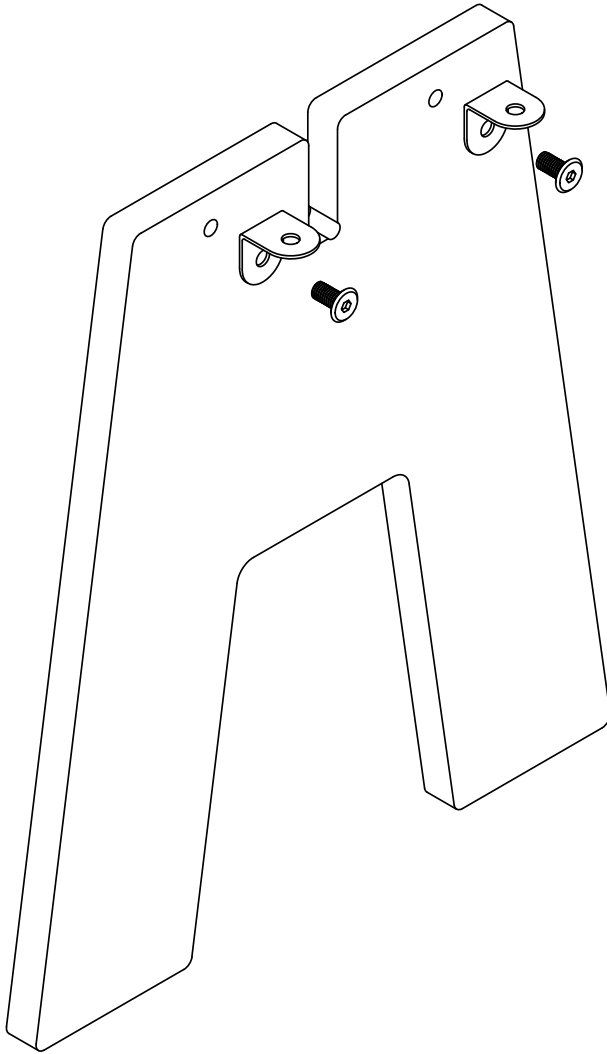

1.

Attach 2 brackets to each plywood leg using the bolts. The fittings are pre-inserted into the plywood.

Loosely tighten the bolts using the hex key. Don't fully tighten them yet.

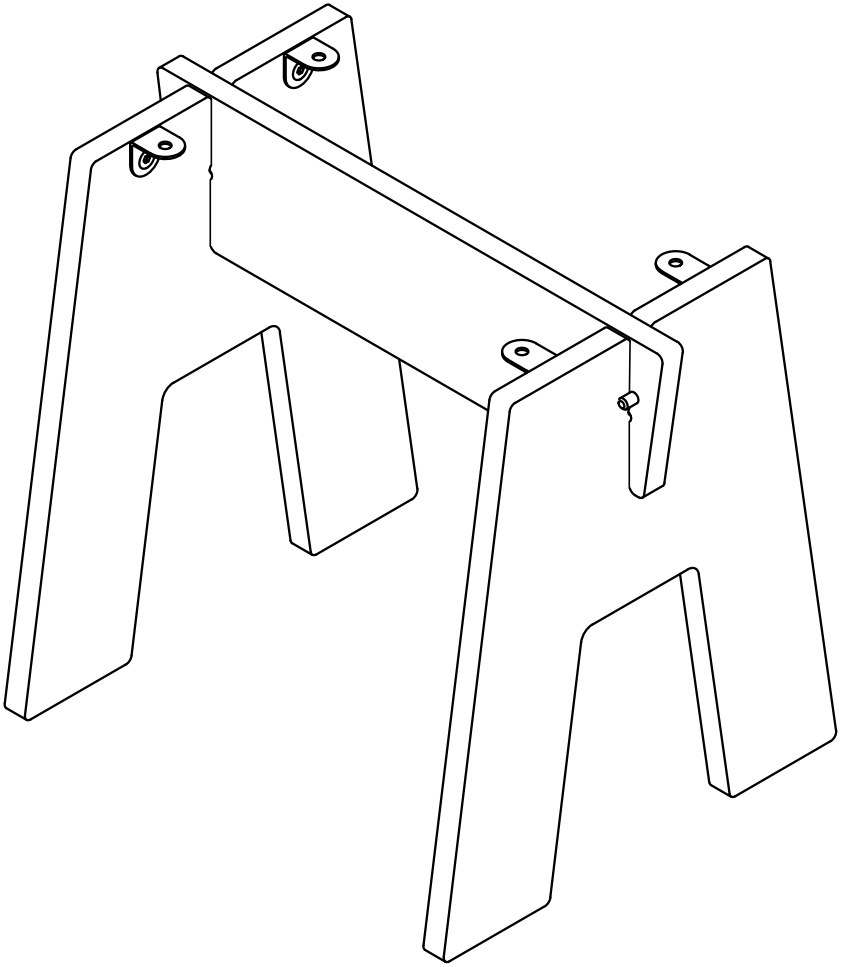

2.

Fit the Stretcher onto the legs.
Make sure it is pushed all the way
down.

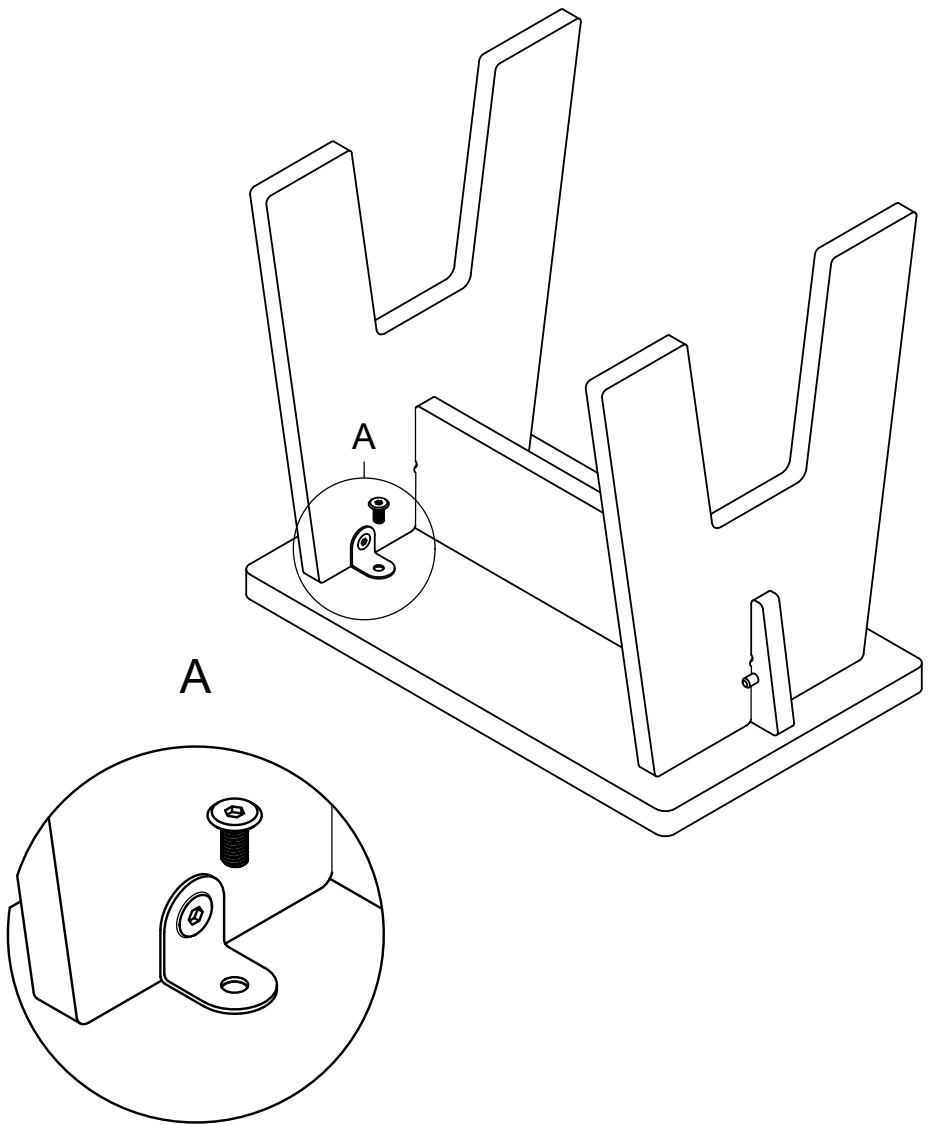

<p>3.</p>	<p>Turn the Foresso stool top upside down and position the base on it.</p> <p>Then use the bolts to fix the top to the base.</p> <p>Finally, tighten all the bolts.</p>
-----------	---



FORESSO[®]

Unit Q1, Hawthorns Ind. Est.
Middlemore Road
Birmingham B21 0BH

0203 302 7387
sales@foresso.co.uk