

EMC TEST REPORT
for
Lumatek Ltd.

Grow Light Reflectors

Model No: Commodore, R-type, Commodore, Xenon2, Arkanoid, Outrun, Last Ninja,
Tekken, Armalyte, Barbarian, Thrust

Prepared for : Lumatek Ltd.
Address : Unit 8KPC Business Centre Ashford Kent TN24 OBP United
kingdom

Prepared By : Shenzhen Accurate Technology Co., Ltd.
Address : 1/F., Building A, Changyuan New Material Port, Science &
Industry Park, Nanshan District, Shenzhen, Guangdong, P.R.
China

Tel: (+86-755) 26503290
Fax: (+86-755) 26503396

Report No. : ATE20180312
Date of Test : March 8, 2018
Date of Report : March 12, 2018

TABLE OF CONTENTS

Description	Page
Test Report	
1. TEST RESULTS SUMMARY	6
2. GENERAL INFORMATION.....	7
2.1. Description of Device (EUT)	7
2.2. Accessory and Auxiliary Equipment	7
2.3. Description of Test Facility	8
2.4. Measurement Uncertainty	8
3. MEASURING DEVICES AND TEST EQUIPMENT.....	9
3.1. For Conducted Emission Test	9
3.2. For Magnetic Measurement	9
3.3. For Radiated Emission Measurement	10
3.4. For Harmonic & Flicker Test	11
3.5. For Electrostatic Discharge Immunity Test.....	11
3.6. For RF Strength Susceptibility Test.....	11
3.7. For Electrical Fast Transient /Burst Immunity Test	12
3.8. For Surge Immunity Test.....	12
3.9. For Injected Current Susceptibility Test	13
3.10. For Magnetic Field Immunity Test.....	13
3.11. For Voltage Dips and Interruptions Test	13
4. POWER LINE CONDUCTED MEASUREMENT	14
4.1. Block Diagram of Test Setup	14
4.2. Measurement Standard and Limits.....	14
4.3. Power Line Conducted Emission Limits.....	14
4.4. Manufacturer	14
4.5. Operating Condition of EUT	15
4.6. Test Procedure.....	15
4.7. Measurement Results	16
5. MAGNETIC FIELD EMISSION MEASUREMENT.....	19
5.1. Block Diagram of Test Setup	19
5.2. Measurement Standard	19
5.3. Magnetic Field Emission Limits	19
5.4. Manufacturer	19
5.5. Operating Condition of EUT	19
5.6. Test Procedure.....	20
5.7. Test Results.....	20
6. RADIATED EMISSION MEASUREMENT.....	24
6.1. Block Diagram of Test.....	24
6.2. Measuring Standard	24
6.3. Radiated Emission Limits	25
6.4. Manufacturer	25
6.5. Operating Condition of EUT	25
6.6. Test Procedure.....	25
6.7. Measuring Results.....	26

7.	HARMONIC CURRENT MEASUREMENT	29
7.1.	Block Diagram of Test Setup	29
7.2.	Measuring Standard	29
7.3.	Operating Condition of EUT	29
7.4.	Test Results	29
8.	VOLTAGE FLUCTUATIONS & FLICKER MEASUREMENT	33
8.1.	Block Diagram of Test Setup	33
8.2.	Measuring Standard	33
8.3.	Operating Condition of EUT	33
8.4.	Test Results	33
9.	ELECTROSTATIC DISCHARGE TEST	35
9.1.	Block Diagram of Test Setup	35
9.2.	Test Standard	35
9.3.	Severity Levels and Performance Criterion	35
9.4.	Manufacturer	36
9.5.	Operating Condition of EUT	36
9.6.	Test Procedure	36
9.7.	Test Results	36
10.	RF FIELD STRENGTH SUSCEPTIBILITY TEST	38
10.1.	Block Diagram of Test Setup	38
10.2.	Test Standard	38
10.3.	Severity Levels and Performance Criterion	39
10.4.	Manufacturer	39
10.5.	Operating Condition of EUT	39
10.6.	Test Procedure	39
10.7.	Test Results	39
11.	ELECTRICAL FAST TRANSIENT/BURST TEST	41
11.1.	Block Diagram of Test Setup	41
11.2.	Test Standard	41
11.3.	Severity Levels and Performance Criterion	41
11.4.	Manufacturer	41
11.5.	Operating Condition of EUT	42
11.6.	Test Procedure	42
11.7.	Test Result	42
12.	SURGE IMMUNITY TEST	44
12.1.	Block Diagram of Test Setup	44
12.2.	Test Standard	44
12.3.	Severity Levels and Performance Criterion	44
12.4.	Manufacturer	45
12.5.	Operating Condition of EUT	45
12.6.	Test Procedure	45
12.7.	Test Result	45
13.	INJECTED CURRENTS SUSCEPTIBILITY TEST	47
13.1.	Block Diagram of Test Setup	47
13.2.	Test Standard	47
13.3.	Severity Levels and Performance Criterion	47
13.4.	Manufacturer	48
13.5.	Operating Condition of EUT	48
13.6.	Test Procedure	48
13.7.	Test Results	48

14.	MAGNETIC FIELD IMMUNITY TEST	50
14.1.	Block Diagram of Test Setup	50
14.2.	Test Standard	50
14.3.	Severity Levels and Performance Criterion	50
14.4.	Manufacturer	51
14.5.	Operating Condition of EUT	51
14.6.	Test Procedure	51
14.7.	Test Results	51
15.	VOLTAGE DIPS AND INTERRUPTIONS TEST	53
15.1.	Block Diagram of Test Setup	53
15.2.	Test Standard	53
15.3.	Severity Levels and Performance Criterion	53
15.4.	Manufacturer	54
15.5.	Operating Condition of EUT	54
15.6.	Test Procedure	54
15.7.	Test Result	54
16.	PHOTOGRAPH	56
16.1.	Photo of Conducted Emission Measurement	56
16.2.	Photo of Magnetic field Emission Measurement	56
16.3.	Photo of Radiated Measurement	57
16.4.	Photo of Harmonic Current / Flicker Measurement	57
16.5.	Photo of Electrostatic Discharge Test	58
16.6.	Photo of RF Field Strength Susceptibility Test	58
16.7.	Photo of Electrical Fast Transient /Burst Test	59
16.8.	Photo of Surge and Voltage Dips and Interruption Immunity Test	59
16.9.	Photo of Injected Current Susceptibility Test	60
16.10.	Photo of Magnetic Field Susceptibility Test	60
16.11.	Photo of EUT	61

TEST REPORT

Applicant : Lumatek Ltd.
Manufacturer : MingYu Lighting L.T.D.
Product : Grow Light Reflectors
Model No. : Commodore, R-type, Commodore, Xenon2, Arkanoid, Outrun, Last
Ninja, Tekken, Armalyte, Barbarian, Thrust
Trade Mark : n.a.

Measurement Procedure Used:

EN 55015: 2013 +A1: 2015;
EN 61000-3-2: 2014;
EN 61000-3-3: 2013;
EN 61547: 2009 (IEC61000-4-2: 2008; IEC61000-4-3: 2006 +A1:2007 +A2:2010
IEC61000-4-4: 2012; IEC61000-4-5: 2014 +A1:2017
IEC61000-4-6: 2013; IEC61000-4-8: 2009
IEC61000-4-11: 2004 +A1:2017)

The device described above is tested by Shenzhen Accurate Technology Co., Ltd. To determine the maximum emission levels emanating from the device and the severe levels of the device can endure and its performance criterion. The measurement results are contained in this test report and Shenzhen Accurate Technology Co., Ltd. is assumed full responsibility for the accuracy and completeness of these measurements. Also, this report shows that the EUT to be technically compliant with the EN 55015, EN 61000-3-2, EN 61000-3-3 and EN 61547 requirements.

This report applies to above tested sample only and shall not be reproduced in part without written approval of Shenzhen Accurate Technology Co., Ltd.

Date of Test : March 8, 2018
Date of Report: March 12, 2018

Prepared by : _____
(Bob Wang, Engineer)

Approved & Authorized Signer : _____
(Sean Liu, Manager)



1. TEST RESULTS SUMMARY

Test Items	Test Standard	Test Results
Power Line Conducted Emission	EN 55015: 2013 +A1: 2015	Pass
Magnetic Field Emission	EN 55015: 2013 +A1: 2015	Pass
Radiated Emission	EN 55015: 2013 +A1: 2015	Pass
Harmonic Current	EN 61000-3-2: 2014	Pass
Voltage Fluctuation and Flicker	EN 61000-3-3: 2013	Pass
Electrostatic Discharge Immunity	EN 61547: 2009 (IEC 61000-4-2: 2008)	Pass
Radiated Electromagnetic Fields Immunity	EN 61547: 2009 (IEC 61000-4-3: 2006 +A1:2007 +A2:2010)	Pass
Electrical Fast Transients/Bursts Immunity	EN 61547: 2009 (IEC 61000-4-4: 2012)	Pass
Surge Immunity	EN 61547: 2009 (IEC 61000-4-5: 2014 +A1:2017)	Pass
Injected Current Susceptibility Test	EN 61547: 2009 (IEC 61000-4-6: 2013)	Pass
Magnetic Field Immunity	EN 61547: 2009 (IEC 61000-4-8: 2009)	Pass
Voltage dips and interruptions Immunity	EN 61547: 2009 (IEC 61000-4-11: 2004 +A1:2017)	Pass

2. GENERAL INFORMATION

2.1. Description of Device (EUT)

Product : Grow Light Reflectors

Model Number : Commodore, R-type, Commodore, Xenon2, Arkanoid, Outrun, Last Ninja, Tekken, Armalyte, Barbarian, Thrust
(Note: These samples are same except their appearance is different. So we prepare Commodore for test only.)

Trade Mark : n.a.

Rating : AC 230V; 50Hz

Applicant : Lumatek ltd.
Address : Unit 8KPC Business Centre Ashford Kent TN24 OBP
United kingdom

Manufacturer : MingYu Lighting L.T.D.
Address : FuXing Industrial Zone, YuanZhou Town, Huizhou City,
GuangDong Province, China

Date of sample : March 7, 2018
receiver

Date of Test : March 8, 2018

Sample number : 1800230

2.2. Accessory and Auxiliary Equipment

n.a.

2.3. Description of Test Facility

EMC Lab	: Recognition of accreditation by Federal Communications Commission (FCC) The Designation Number is CN1189 The Registration Number is 708358
	Listed by Innovation, Science and Economic Development Canada (ISED) The Registration Number is 5077A-2
	Accredited by China National Accreditation Service for Conformity Assessment (CNAS) The Registration Number is CNAS L3193
	Accredited by American Association for Laboratory Accreditation (A2LA) The Certificate Number is 4297.01
Name of Firm	: Shenzhen Accurate Technology Co., Ltd.
Site Location	: 1/F., Building A, Changyuan New Material Port, Science & Industry Park, Nanshan District, Shenzhen, Guangdong, P.R. China
Subcontracted Items:	: RF Strength Susceptibility Test
Subcontractor	: Shenzhen Academy Of Metrology And Quality Inspection
Site Location	: Bldg. Of Shenzhen Academy Of Metrology And Quality Inspection, Longzhu Road, Nanshan, Shenzhen, Guangdong P. R. China

2.4. Measurement Uncertainty

Conducted emission expanded uncertainty	: U=2.23dB, k=2
Power disturbance expanded uncertainty	: U=2.92dB, k=2
Radiated emission expanded uncertainty (9kHz-30MHz)	: U=3.08dB, k=2
Radiated emission expanded uncertainty (30MHz-1000MHz)	: U=4.42dB, k=2
Radiated emission expanded uncertainty (Above 1GHz)	: U=4.06dB, k=2
Magnetic field emission expanded uncertainty (9kHz-30MHz)	: U=2.42dB, k=2
Harmonic current expanded uncertainty	: U=0.512%, k=2

3. MEASURING DEVICES AND TEST EQUIPMENT

3.1. For Conducted Emission Test

Item	Equipment	Manufacturer	Model No.	Serial No.	Last Cal.	Cal. Interval
1.	Test Receiver	Rohde & Schwarz	ESCS30	100307	Jan.06, 2018	1 Year
2.	Test Receiver	Rohde & Schwarz	ESPI	100396/003	Jan.06, 2018	1 Year
3.	Test Receiver	Rohde & Schwarz	ESPI	101526/003	Jan.06, 2018	1 Year
4.	Test Receiver	Rohde & Schwarz	ESR	101817	Jan.06, 2018	1 Year
5.	L.I.S.N.	Schwarzbeck	NLSK8126	8126431	Jan.06, 2018	1 Year
6.	L.I.S.N.	Rohde & Schwarz	ESH3-Z5	100305	Jan.06, 2018	1 Year
7.	L.I.S.N.	Rohde & Schwarz	ESH3-Z5	100310	Jan.06, 2018	1 Year
8.	L.I.S.N.	Rohde & Schwarz	ESH3-Z6	100132	Jan.06, 2018	1 Year
9.	L.I.S.N.	Rohde & Schwarz	ESH3-Z6	100979	Jan.06, 2018	1 Year
10.	Pulse Limiter	Rohde & Schwarz	ESH3-Z2	100305	Jan.06, 2018	1 Year
11.	Pulse Limiter	Rohde & Schwarz	ESH3-Z2	100312	Jan.06, 2018	1 Year
12.	Pulse Limiter	Rohde & Schwarz	ESH3-Z2	100815	Jan.06, 2018	1 Year
13.	50Ω Coaxial Switch	Anritsu Corp	MP59B	620028393 6	Jan.06, 2018	1 Year
14.	50Ω Coaxial Switch	Anritsu Corp	MP5 Jan.06, 20189B	620028393 3	Jan.06, 2018	1 Year
15.	50Ω Coaxial Switch	Anritsu Corp	MP59B	620050647 4	Jan.06, 2018	1 Year
16.	VOLTAGE PROBE	Schwarzbeck	TK9416	N/A	Jan.06, 2018	1 Year
17.	RF CURRENT PROBE	Rohde & Schwarz	EZ-17	100048	Jan.06, 2018	1 Year
18.	8-Wire Impedance Stabilisation Network	Schwarzbeck	CAT5 8158	8158-0035	Jan.06, 2018	1 Year
19.	RF Coaxial Cable	SUHNER	N-2m	No.2	Jan.06, 2018	1 Year
20.	RF Coaxial Cable	SUHNER	N-2m	No.3	Jan.06, 2018	1 Year
21.	RF Coaxial Cable	SUHNER	N-2m	No.14	Jan.06, 2018	1 Year

3.2. For Magnetic Measurement

Item	Equipment	Manufacturer	Model No.	Serial No.	Last Cal.	Cal. Interval
1.	Test Receiver	Rohde & Schwarz	ESCS30	100307	Jan.06, 2018	1 Year
2.	Test Receiver	Rohde & Schwarz	ESPI	100396/003	Jan.06, 2018	1 Year
3.	Test Receiver	Rohde & Schwarz	ESPI	101526/003	Jan.06, 2018	1 Year
4.	Test Receiver	Rohde & Schwarz	ESR	101817	Jan.06, 2018	1 Year
5.	Triple Loop Antenna	CD	LASM-2	LASM-2 X001 Y001 Z001	Jan.12, 2018	1 Year

3.3.For Radiated Emission Measurement

Item	Equipment	Manufacturer	Model No.	Serial No.	Last Cal.	Cal. Interval
1.	Spectrum Analyzer	Agilent	E7405A	MY45115511	Jan.06, 2018	1 Year
2.	Spectrum Analyzer	Rohde&Schwarz	FSV40	101495	Jan.06, 2018	1 Year
3.	Test Receiver	Rohde&Schwarz	ESCS30	100307	Jan.06, 2018	1 Year
4.	Test Receiver	Rohde& Schwarz	ESPI	100396/003	Jan.06, 2018	1 Year
5.	Test Receiver	Rohde& Schwarz	ESPI	101526/003	Jan.06, 2018	1 Year
6.	Test Receiver	Rohde& Schwarz	ESR	101817	Jan.06, 2018	1 Year
7.	Bilog Antenna	Schwarzbeck	VULB9163	9163-194	Jan.12, 2018	1 Year
8.	Bilog Antenna	Schwarzbeck	VULB9163	9163-323	Jan.12, 2018	1 Year
9.	Log.-Per.Antenna	Schwarzbeck	VUSLP 9111B	9111B-074	Jan.12, 2018	1 Year
10.	Biconical Broad Band Antenna	Schwarzbeck	VHBB 9124+BBA 9106	9124-617	Jan.12, 2018	1 Year
11.	Loop Antenna	Schwarzbeck	FMZB1516	1516131	Jan.12, 2018	1 Year
12.	Horn Antenna	Schwarzbeck	BBHA9120D	9120D-655	Jan.12, 2018	1 Year
13.	Horn Antenna	Schwarzbeck	BBHA9120D	9120D-1067	Jan.12, 2018	1 Year
14.	Vertical Active Monopole Antenna	Schwarzbeck	VAMP 9243	9243-370	Jan.12, 2018	1 Year
15.	Pre-Amplifier	Compliance Direction	RSU-M2	38322	Jan.06, 2018	1 Year
16.	Pre-Amplifier	Agilent	8447D	294A10619	Jan.06, 2018	1 Year
17.	Pre-Amplifier	Rohde&Schwarz	CBLU11835 40-01	3791	Jan.06, 2018	1 Year
18.	Pre-Amplifier	A.H. System	PAM-0118	135	Jan.06, 2018	1 Year
19.	50 Coaxial Switch	Anritsu Corp	MP59B	6200237248	Jan.06, 2018	1 Year
20.	50 Coaxial Switch	Anritsu Corp	MP59B	6200506474	Jan.06, 2018	1 Year
21.	RF Coaxial Cable	Schwarzbeck	N-5m	No.1	Jan.06, 2018	1 Year
22.	RF Coaxial Cable	Schwarzbeck	N-1m	No.6	Jan.06, 2018	1 Year
23.	RF Coaxial Cable	Schwarzbeck	N-1m	No.7	Jan.06, 2018	1 Year
24.	RF Coaxial Cable	SUHNER	N-3m	No.8	Jan.06, 2018	1 Year
25.	RF Coaxial Cable	RESENBERGER	N-3.5m	No.9	Jan.06, 2018	1 Year
26.	RF Coaxial Cable	SUHNER	N-6m	No.10	Jan.06, 2018	1 Year
27.	RF Coaxial Cable	RESENBERGER	N-12m	No.11	Jan.06, 2018	1 Year
28.	RF Coaxial Cable	RESENBERGER	N-0.5m	No.12	Jan.06, 2018	1 Year
29.	RF Coaxial Cable	SUHNER	N-2m	No.13	Jan.06, 2018	1 Year
30.	RF Coaxial Cable	SUHNER	N-0.5m	No.15	Jan.06, 2018	1 Year
31.	RF Coaxial Cable	SUHNER	N-2m	No.16	Jan.06, 2018	1 Year
32.	RF Coaxial Cable	RESENBERGER	N-6m	No.17	Jan.06, 2018	1 Year

3.4.For Harmonic & Flicker Test

Item	Equipment	Manufacturer	Model No.	Serial No.	Last Cal.	Cal. Interval
1.	AC Power Source	California Instruments	500iX-400	55689	Jan.06, 2018	1 Year
2.	Test analyzer	California Instruments	PACS-1	72254	Jan.06, 2018	1 Year

3.5.For Electrostatic Discharge Immunity Test

Item	Equipment	Manufacturer	Model No.	Serial No.	Last Cal.	Cal. Interval
1.	ESD Generator	TESEQ	NSG 437	823	Jan.06, 2018	1 Year

3.6.For RF Strength Susceptibility Test

Item	Equipment	Manufacturer	Model No.	Eqpt No.	Last Cal.	Cal. Interval
1.	Signal Generator	Rohde & Schwarz	SMB100A	SB9422/02	Jul.03, 2017	1 Year
2.	Signal Generator	Rohde & Schwarz	SMF100A	SB8501/03	Apr.24, 2017	1 Year
3.	Voltage Meter	Rohde & Schwarz	URV5-Z2	SB9422/03	Apr.24, 2017	1 Year
4.	Voltage Meter	Rohde & Schwarz	URV5-Z2	SB9422/04	Apr.24, 2017	1 Year
5.	Power Probe	Rohde & Schwarz	NRP-Z81	SB9422/06	Apr.15, 2017	1 Year
6.	Power Probe	Rohde & Schwarz	NRP-Z81	SB9422/07	Apr.15, 2017	1 Year
7.	Power Meter	Rohde & Schwarz	NRP	SB9422/05	Apr.15, 2017	1 Year
8.	Power Amplifier	PRANA	MT310A	SB9422/08	Mar.28, 2017	1 Year
9.	Broadband Antenna	Rohde & Schwarz	HL046E	SB9422/13	Mar.28, 2017	1 Year
10.	Horn Antenna	AR	ATH800M5G A	SB9422/15	Mar.28, 2017	1 Year
11.	Power Amplifier	MILMEGA	A-001	SB9422/10	Mar.28, 2017	1 Year
12.	Power Meter	Rohde & Schwarz	NRVD	SB3437	Jul.03, 2017	1 Year

3.7.For Electrical Fast Transient /Burst Immunity Test

Item	Equipment	Manufacturer	Model No.	Serial No.	Last Cal.	Cal. Interval
1.	ULTRA COMPACT SIMULATOR	EM TEST	UCS 500 N5	V0928104968	Jan.06, 2018	1Year
2.	CAPACITIVE CLAMP	EM TEST	HFK	0509-34	Jan.06, 2018	1Year
3.	EMCPRO SYSTEM (IMMUNITY TESTER)	THERMO	EMC PRO Plus-BASE	1108237	Jan.06, 2018	1Year
4.	EMCPRO SYSTEM (IMMUNITY TESTER)	THERMO	EMC PRO -BASE	0403271	Jan.06, 2018	1Year

3.8.For Surge Immunity Test

Item	Equipment	Manufacturer	Model No.	Serial No.	Last Cal.	Cal. Interval
1.	ULTRA COMPACT SIMULATOR	EM TEST	UCS 500 N5	V0928104968	Jan.06, 2018	1Year
2.	EMCPRO SYSTEM (IMMUNITY TESTER)	THERMO	EMC PRO Plus-BASE	1108237	Jan.06, 2018	1Year
3.	COUPLER DECOUPLER FOR TELECOM LINES	THERMO	CM-TEL-CD	0403273	Jan.06, 2018	1Year
4.	EMCPRO SYSTEM (IMMUNITY TESTER)	THERMO	EMC PRO -BASE	0403271	Jan.06, 2018	1Year

3.9.For Injected Current Susceptibility Test

Item	Equipment	Manufacturer	Model No.	Serial No.	Last Cal.	Cal. Interval
1.	Conducted Immunity Test System	FRANKONIA	CIT-10	126B1121	Jan.06, 2018	1Year
2.	CDN	FRANKONIA	CDN-M2/3	A3027020	Jan.06, 2018	1Year
3.	EM Injection Clamp	FCC	F-203I-23mm	091824	Jan.06, 2018	1Year
4.	6dB Attenuator	Weinschel	WA59-6-33	A329	Jan.06, 2018	1Year

3.10.For Magnetic Field Immunity Test

Item	Equipment	Manufacturer	Model No.	Serial No.	Last Cal.	Cal. Interval
1.	Magnetic Field Tester	HAEFELY	MAG100	150577	Jan.06, 2018	1 Year

3.11.For Voltage Dips and Interruptions Test

Item	Equipment	Manufacturer	Model No.	Serial No.	Last Cal.	Cal. Interval
1.	ULTRA COMPACT SIMULATOR	EM TEST	UCS 500 N5	V0928104968	Jan.06, 2018	1Year
2.	EMCPRO SYSTEM (IMMUNITY TESTER)	THERMO	EMC PRO Plus-BASE	1108237	Jan.06, 2018	1Year

4. POWER LINE CONDUCTED MEASUREMENT

4.1. Block Diagram of Test Setup

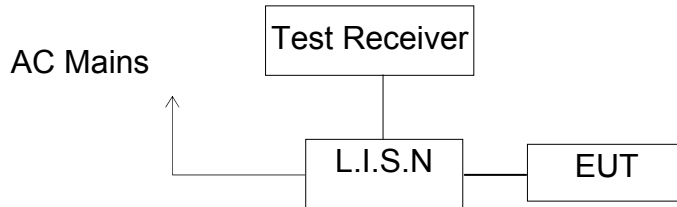

(EUT: Grow Light Reflectors)

4.2. Measurement Standard and Limits

EN 55015: 2013 +A1: 2015

4.3. Power Line Conducted Emission Limits

Frequency	At mains terminals dB(μ V)	
	Quasi-peak Level	Average Level
9kHz - 50KHz	110	--
50kHz - 150KHz	90 - 80*	--
150kHz - 0.5MHz	66 - 56*	56 - 46*
0.5MHz - 5.0MHz	56	46
5.0MHz - 30.0MHz	60	50

1. At the transition frequency the lower limit applies.
2. * Decreasing linearly with logarithm of the frequency.

4.4. Manufacturer

The following equipments are installed on Conducted Emission Measurement to meet EN55015 requirements and operating in a manner which tends to maximize its emission characteristics in a normal application.

4.4.1. Grow Light Reflectors (EUT)

Model No. : Commodore
 Manufacturer : MingYu Lighting L.T.D.

4.5. Operating Condition of EUT

4.5.1. Setup the EUT as shown in Section 4.1.

4.5.2. Turn on the power of all equipments.

4.5.3. Let the EUT work in test mode (ON) and measure it.

4.6. Test Procedure

The EUT is put on the table which is 0.8 meter high above the ground and connected to the AC mains through a Line Impedance Stabilization Network (L.I.S.N.). This provided a 50ohm coupling impedance for the tested equipments. Both sides of AC line are checked to find out the maximum conducted emission according to the EN 55015 regulations during conducted emission measurement. And the voltage probe had been used for the load terminals measurement according to the EN 55015 standard.

The bandwidth of the test receiver (R&S ESCS30) is set at 200Hz in 9k~150kHz range and 9kHz in 150k~30MHz range.

The frequency range from 9 kHz to 30MHz is checked.

4.7.Measurement Results

PASS.

Test mode : ON								
MEASUREMENT RESULT: "T-0062-01_fin"								
3/8/2018 10:16AM								
Frequency MHz	Level dBμV	Transd dB	Limit dBμV	Margin dB	Detector	Line	PE	
0.099800	53.90	10.4	84	29.8	QP	N	GND	
0.155000	60.50	10.5	66	5.2	QP	N	GND	
3.740000	37.10	11.1	56	18.9	QP	N	GND	
MEASUREMENT RESULT: "T-0062-01_fin2"								
3/8/2018 10:16AM								
Frequency MHz	Level dBμV	Transd dB	Limit dBμV	Margin dB	Detector	Line	PE	
0.180000	44.20	10.5	55	10.3	AV	N	GND	
0.585000	36.90	10.7	46	9.1	AV	N	GND	
2.110000	22.90	11.0	46	23.1	AV	N	GND	
MEASUREMENT RESULT: "T-0062-02_fin"								
3/8/2018 10:22AM								
Frequency MHz	Level dBμV	Transd dB	Limit dBμV	Margin dB	Detector	Line	PE	
0.100200	54.20	10.4	84	29.5	QP	L1	GND	
0.155000	60.30	10.5	66	5.4	QP	L1	GND	
3.090000	39.80	11.1	56	16.2	QP	L1	GND	
MEASUREMENT RESULT: "T-0062-02_fin2"								
3/8/2018 10:22AM								
Frequency MHz	Level dBμV	Transd dB	Limit dBμV	Margin dB	Detector	Line	PE	
0.180000	44.60	10.5	55	9.9	AV	L1	GND	
0.425000	40.70	10.7	47	6.6	AV	L1	GND	
2.320000	27.10	11.0	46	18.9	AV	L1	GND	

Note: Emissions attenuated more than 20 dB below the permissible value are not reported.

The spectral diagrams are attached as below.

ACCURATE TECHNOLOGY CO.,LTD

CONDUCTED EMISSION STANDARD EN55015

EUT: Grow Light Reflectors M/N:Commodore
 Manufacturer: MingYu
 Operating Condition: ON
 Test Site: 1# Shielding Room
 Operator: Ben
 Test Specification: N 230V/50Hz
 Comment: Report NO.:ATE20180312
 Start of Test: 3/8/2018 / 10:15:14AM

SCAN TABLE: "V 9K-30MHz fin"

Short Description:		_SUB_STD_VTERM2 1.70				
Start Frequency	Stop Frequency	Step Width	Detector	Meas. Time	IF Bandw.	Transducer
9.0 kHz	150.0 kHz	100.0 Hz	QuasiPeak	1.0 s	200 Hz	NSLK8126 2008
150.0 kHz	30.0 MHz	5.0 kHz	Average			
			QuasiPeak	1.0 s	9 kHz	NSLK8126 2008
			Average			

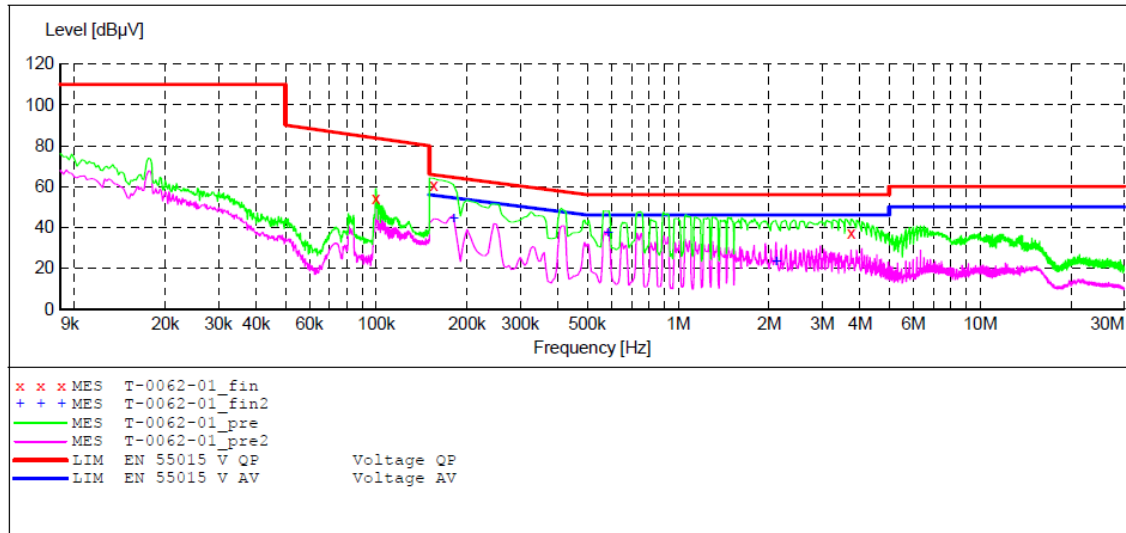

MEASUREMENT RESULT: "T-0062-01_fin"

3/8/2018 10:16AM

Frequency MHz	Level dBuV	Transd dB	Limit dBuV	Margin dB	Detector	Line	PE
0.099800	53.90	10.4	84	29.8	QP	N	GND
0.155000	60.50	10.5	66	5.2	QP	N	GND
3.740000	37.10	11.1	56	18.9	QP	N	GND

MEASUREMENT RESULT: "T-0062-01_fin2"

3/8/2018 10:16AM

Frequency MHz	Level dBuV	Transd dB	Limit dBuV	Margin dB	Detector	Line	PE
0.180000	44.20	10.5	55	10.3	AV	N	GND
0.585000	36.90	10.7	46	9.1	AV	N	GND
2.110000	22.90	11.0	46	23.1	AV	N	GND

ACCURATE TECHNOLOGY CO., LTD

CONDUCTED EMISSION STANDARD EN55015

EUT: Grow Light Reflectors M/N:Commodore
 Manufacturer: MingYu
 Operating Condition: ON
 Test Site: 1# Shielding Room
 Operator: Ben
 Test Specification: L 230V/50Hz
 Comment: Report NO.:ATE20180312
 Start of Test: 3/8/2018 / 10:16:58AM

SCAN TABLE: "V 9K-30MHz fin"

Start Frequency	Stop Frequency	Step Width	Detector	Meas. Time	IF Bandw.	Transducer
9.0 kHz	150.0 kHz	100.0 Hz	QuasiPeak	1.0 s	200 Hz	NSLK8126 2008
150.0 kHz	30.0 MHz	5.0 kHz	Average	1.0 s	9 kHz	NSLK8126 2008

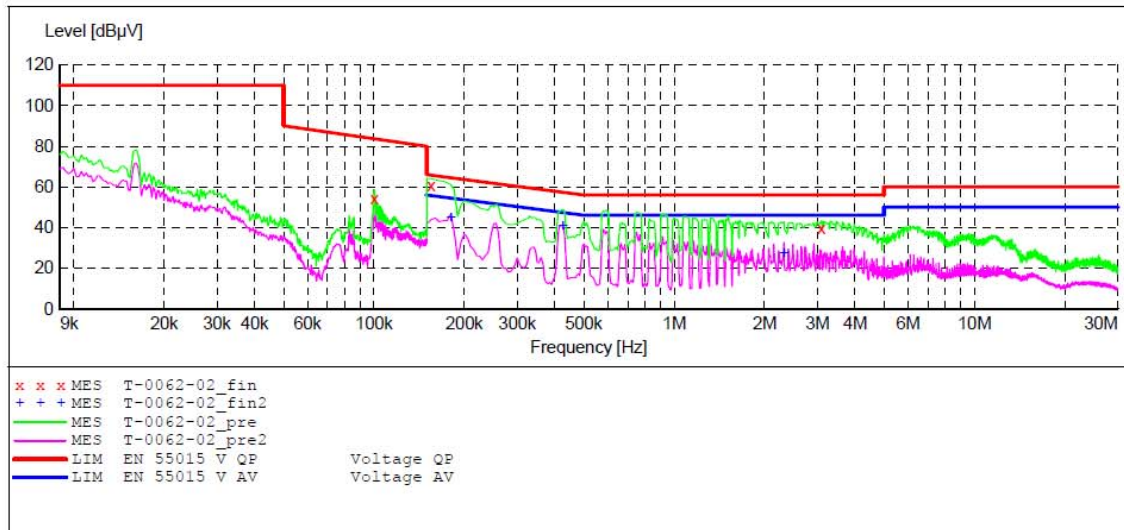

MEASUREMENT RESULT: "T-0062-02_fin"

3/8/2018 10:22AM

Frequency MHz	Level dBµV	Transd dB	Limit dBµV	Margin dB	Detector	Line	PE
0.100200	54.20	10.4	84	29.5	QP	L1	GND
0.155000	60.30	10.5	66	5.4	QP	L1	GND
3.090000	39.80	11.1	56	16.2	QP	L1	GND

MEASUREMENT RESULT: "T-0062-02_fin2"

3/8/2018 10:22AM

Frequency MHz	Level dBµV	Transd dB	Limit dBµV	Margin dB	Detector	Line	PE
0.180000	44.60	10.5	55	9.9	AV	L1	GND
0.425000	40.70	10.7	47	6.6	AV	L1	GND
2.320000	27.10	11.0	46	18.9	AV	L1	GND

5. MAGNETIC FIELD EMISSION MEASUREMENT

5.1. Block Diagram of Test Setup

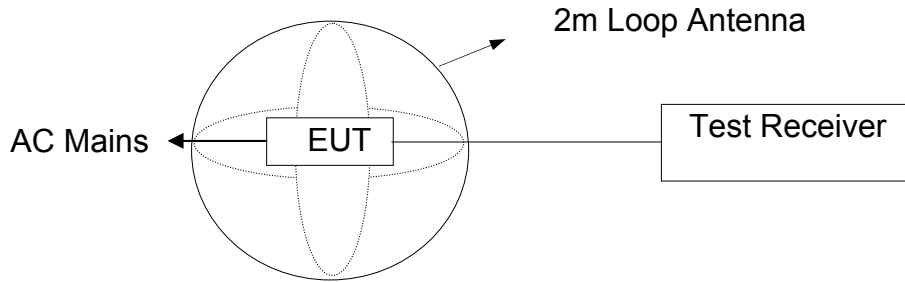

(EUT: Grow Light Reflectors)

5.2. Measurement Standard

EN 55015: 2013 +A1: 2015

5.3. Magnetic Field Emission Limits

Frequency	Limits for loop diameter dB(μ A)
	2m
9kHz - 70kHz	88
70kHz - 150kHz	88 - 58*
150kHz - 3.0MHz	58 - 22*
3.0MHz - 30MHz	22

1. At the transition frequency the lower limit applies.
2. * Decreasing linearly with logarithm of the frequency.

5.4. Manufacturer

The configuration of the EUT is same as Section 4.4.

5.5. Operating Condition of EUT

5.5.1. Setup the EUT as shown in Section 5.1.

5.5.2. Turn on the power of all equipments.

5.5.3. Let the EUT work in test mode (ON) and measure it.

5.6. Test Procedure

The EUT is placed on a wood table in the center of a loop antenna. The induced current in the loop antenna is measured by means of a current probe and the test receiver. Three field components are checked by means of a coaxial switch.

The frequency range from 9 kHz to 30MHz is investigated. The receiver is measured with the quasi-peak detector. For frequency band 9 kHz to 150 kHz, the bandwidth of the field strength meter (R&S test receiver ESCS30) is set at 200Hz. For frequency band 150 kHz to 30MHz, the bandwidth is set at 9 kHz.

5.7. Test Results

PASS.

The frequency range from 9 kHz to 30MHz is investigated.

The spectral diagrams are attached as below.

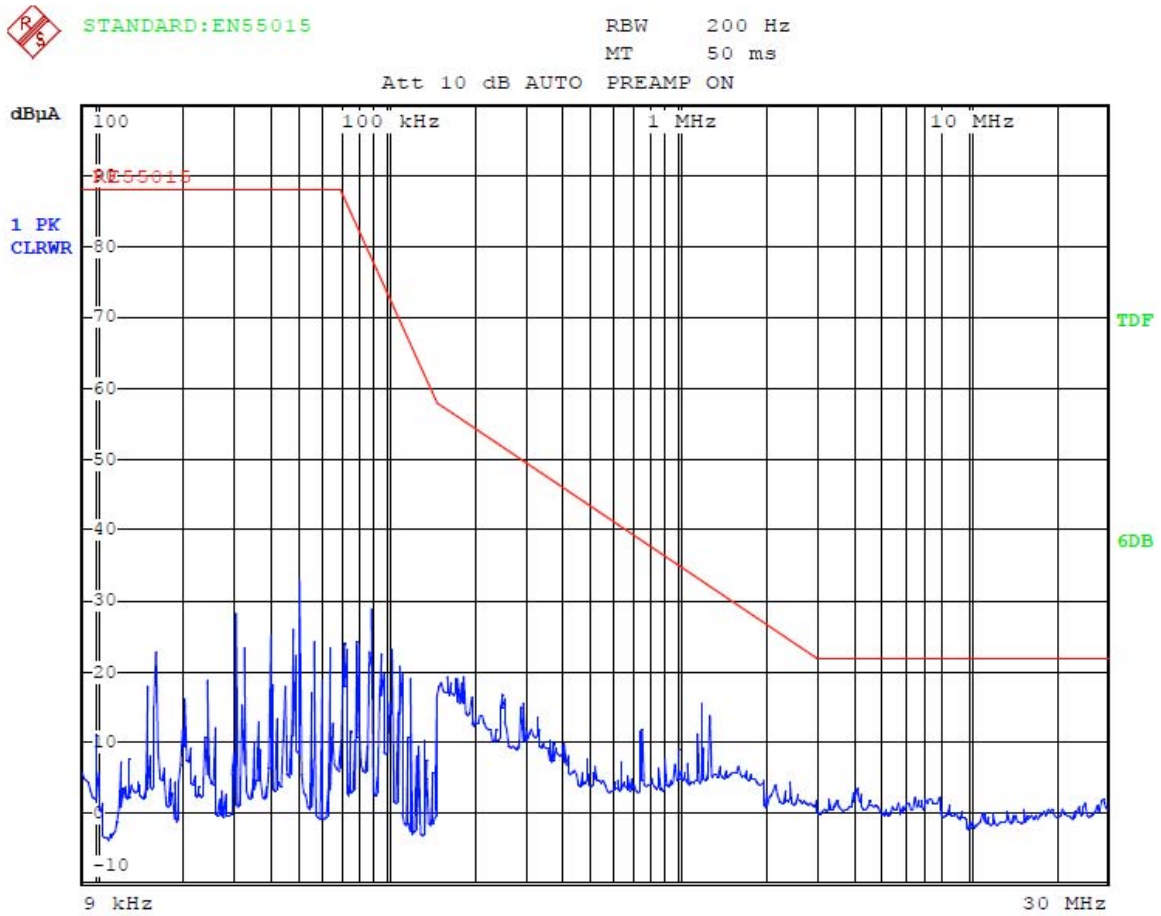

EUT:Grow Light Reflectors M/N:Commodore Test mode:On Power:AC 230V/50Hz X



STANDARD:EN55015

RBW 200 Hz

MT 50 ms

Att 10 dB AUTO PREAMP ON

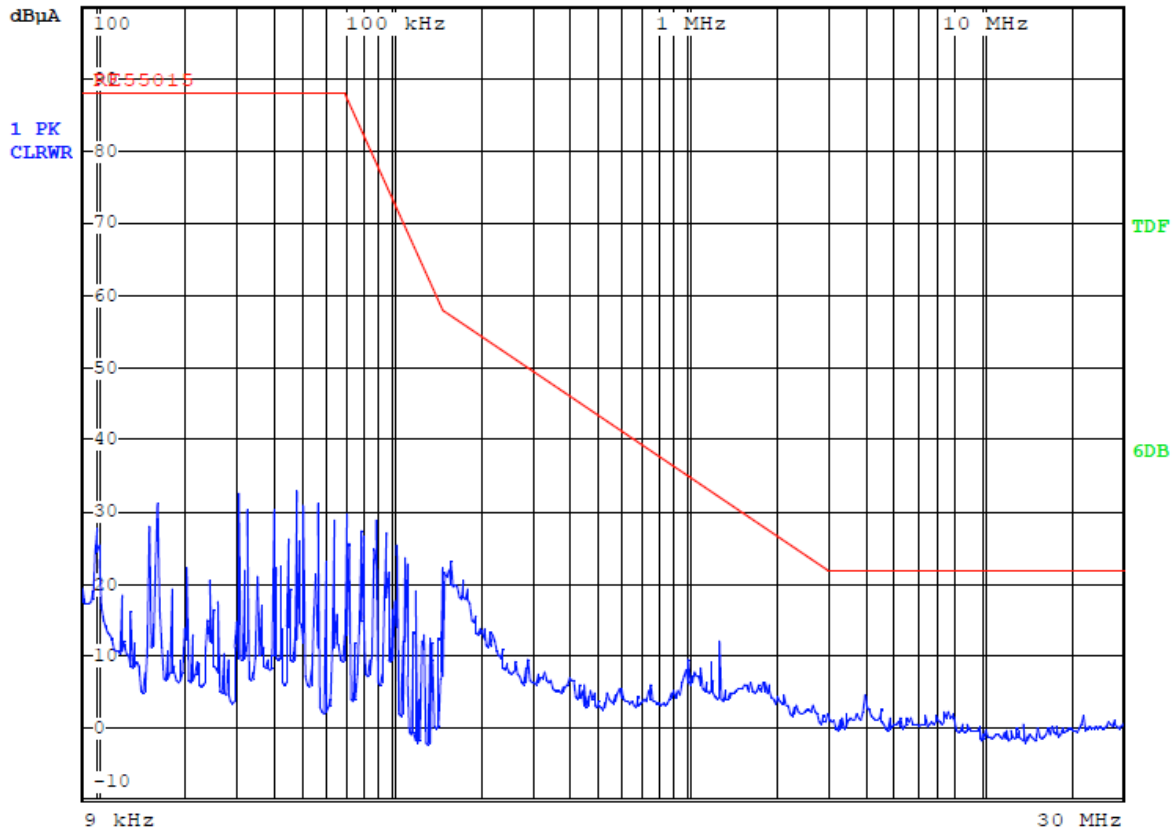

EUT:Grow Light Reflectors M/N:Commodore Test mode:On Power:AC 230V/50Hz Y



STANDARD: EN55015

RBW 200 Hz
MT 50 ms

Att 10 dB AUTO PREAMP ON

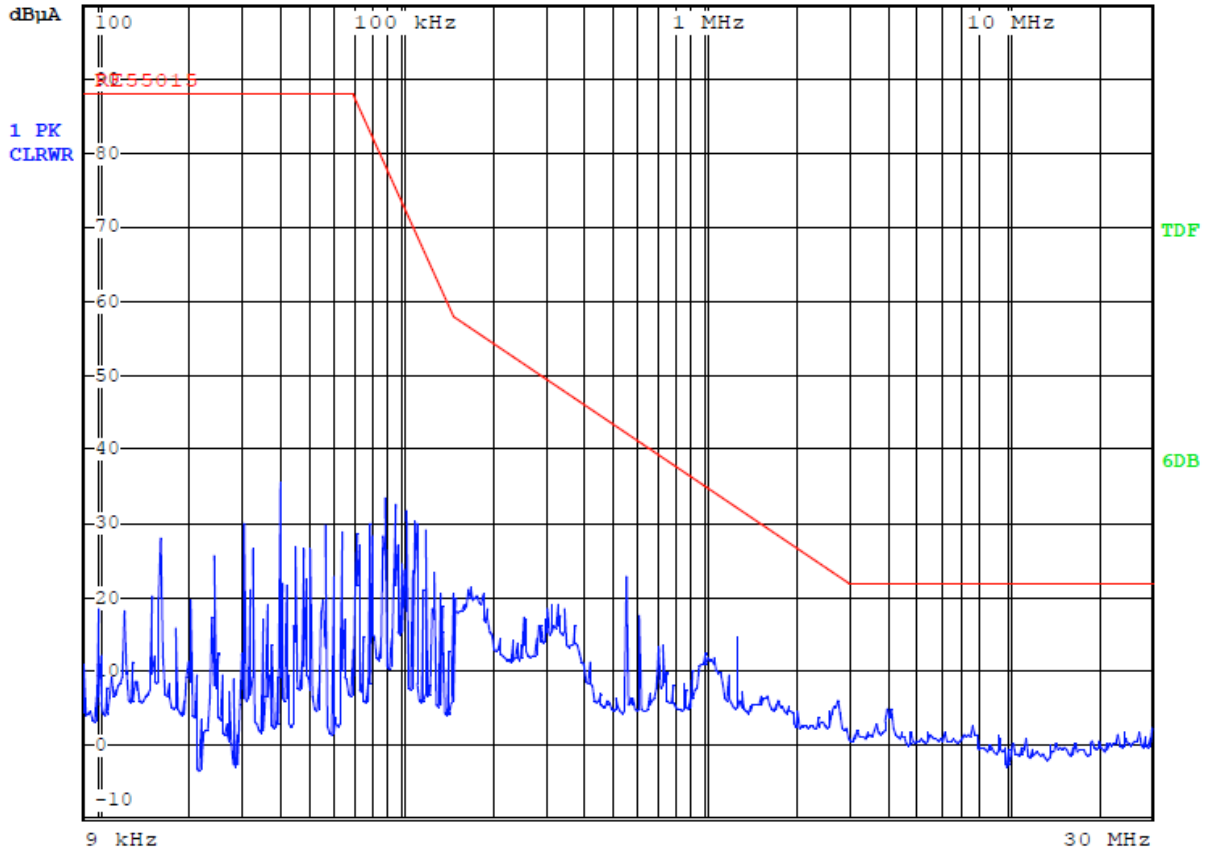

EUT:Grow Light Reflectors M/N:Commodore Test mode:On Power:AC 230V/50Hz Z

6. RADIATED EMISSION MEASUREMENT

6.1. Block Diagram of Test

6.1.1. Block diagram of connection between the EUT and simulators

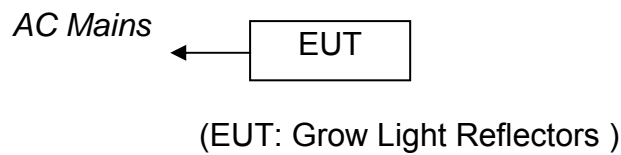

6.1.2. Block diagram of test setup (In chamber)

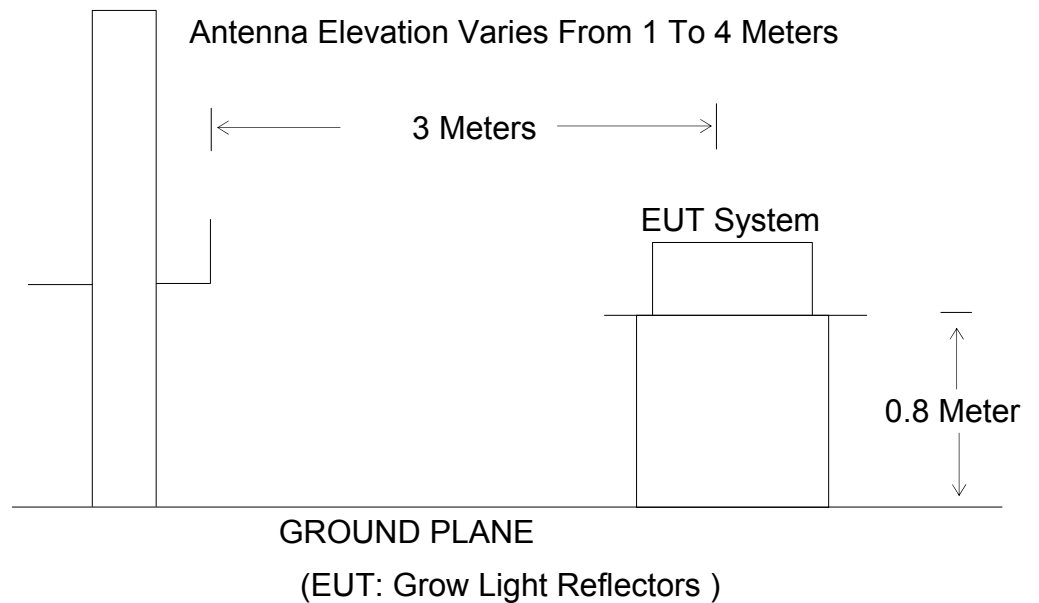

6.2. Measuring Standard

EN 55015: 2013 +A1: 2015

6.3. Radiated Emission Limits

All emanations from a class B device or system, including any network of conductors and apparatus connected thereto, shall not exceed the level of field strengths specified below:

Frequency (MHz)	Distance (Meters)	Field Strengths Limit dB(μ V/m)
30 - 230	3	40
230 - 300	3	47

- Note:
- (1) The smaller limit shall apply at the combination point between two frequency bands.
 - (2) Distance refers to the distance in meters between the measuring instrument antenna and the closed point of any part of the EUT.

6.4. Manufacturer

The EN55015 regulations test method must be used to find the maximum emission during radiated emission measurement.

6.4.1. Grow Light Reflectors (EUT)

Model No.: Commodore

Manufacturer: MingYu Lighting L.T.D.

6.5. Operating Condition of EUT

6.5.1. Turn on the power.

6.5.2. Let the EUT work in test mode (ON) and measure it.

6.6. Test Procedure

The EUT is placed on a turntable, which is 0.8 meter high above the ground. The turntable can rotate 360 degrees to determine the position of the maximum emission level. The EUT is set 3 meters away from the receiving antenna, which is mounted on an antenna tower. The antenna can be moved up and down from 1 to 4 meters to find out the maximum emission level. Bilog antenna (calibrated by Dipole Antenna) is used as a receiving antenna. Both horizontal and vertical polarizations of the antenna are set on test.

The bandwidth of the Receiver (ESCS30) is set at 120kHz.

6.7. Measuring Results

PASS.

The frequency range from 30MHz to 300MHz is investigated.

Test Mode: ON								
Polarization								
Horizontal	No.	Freq. (MHz)	Reading (dBuV/m)	Factor (dB)	Result (dBuV/m)	Limit (dBuV/m)	Margin (dB)	Detector
	1	124.0039	58.85	-27.56	31.29	40.00	-8.71	QP
	2	167.2418	54.66	-26.29	28.37	40.00	-11.63	QP
	3	201.7975	52.68	-24.29	28.39	40.00	-11.61	QP
Vertical	No.	Freq. (MHz)	Reading (dBuV/m)	Factor (dB)	Result (dBuV/m)	Limit (dBuV/m)	Margin (dB)	Detector
	1	94.9784	54.70	-27.42	27.28	40.00	-12.72	QP
	2	125.7412	64.24	-27.60	36.64	40.00	-3.36	QP
	3	164.5491	62.82	-26.59	36.23	40.00	-3.77	QP

Note: Emissions attenuated more than 20 dB below the permissible value are not reported.

The spectral diagrams are attached as below.



ACCURATE TECHNOLOGY CO., LTD.

F1,Bldg,A,Changyuan New Material Port Keyuan Rd,
Science & Industry Park,Nanshan Shenzhen,P.R.China

Site: 1# Chamber
Tel:+86-0755-26503290
Fax:+86-0755-26503396

Job No.: JP2017 #229	Polarization: Vertical
Standard: EN55015	Power Source: AC 230V/50Hz
Test item: Radiation Test	Date: 18/03/08/
Temp.(C)/Hum.(%) 25 C / 55 %	Time: 11/26/56
EUT: Grow Light Reflectors	Engineer Signature: Ben
Mode: ON	Distance: 3m
Model: Commodore	
Manufacturer: MingYu	

Note: Report NO.:ATE20180312

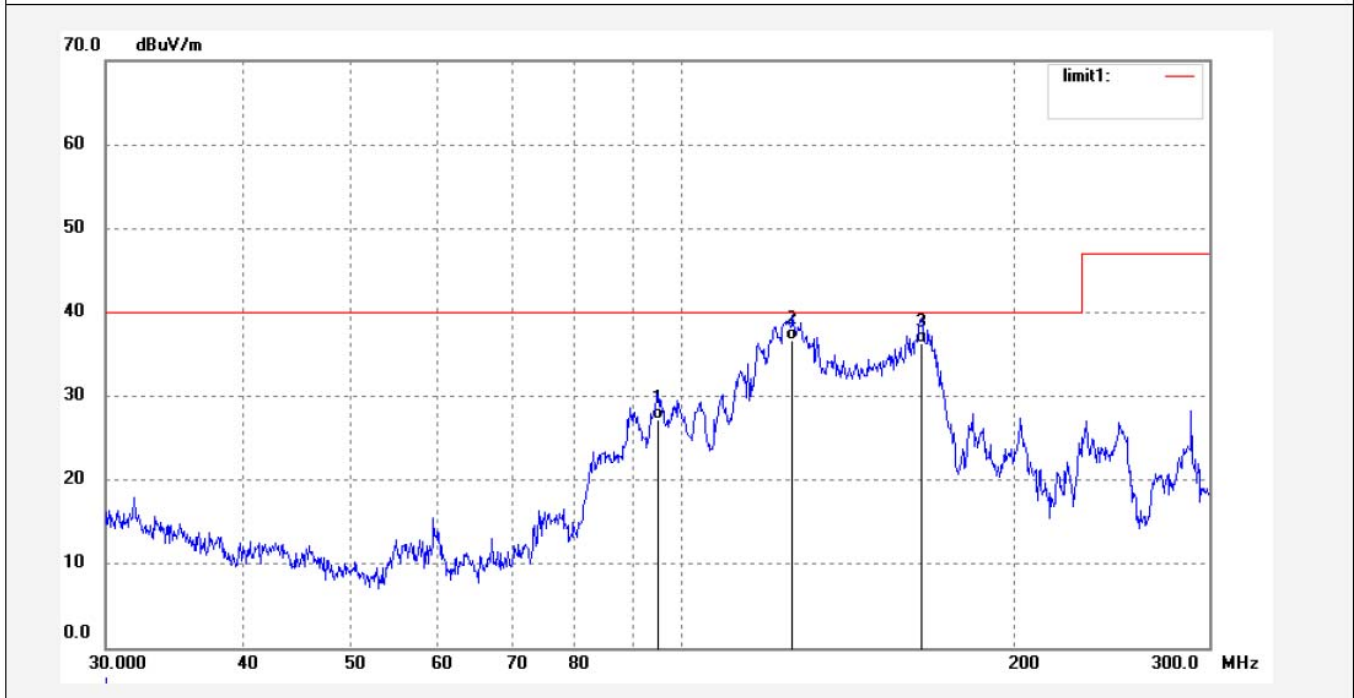

No.	Freq. (MHz)	Reading (dBuV/m)	Factor (dB)	Result (dBuV/m)	Limit (dBuV/m)	Margin (dB)	Detector	Height (cm)	Degree (deg.)	Remark
1	94.9784	54.70	-27.42	27.28	40.00	-12.72	QP			
2	125.7412	64.24	-27.60	36.64	40.00	-3.36	QP			
3	164.5491	62.82	-26.59	36.23	40.00	-3.77	QP			



ACCURATE TECHNOLOGY CO., LTD.

F1,Bldg.A,Changyuan New Material Port Keyuan Rd,
Science & Industry Park,Nanshan Shenzhen,P.R.China

Site: 1# Chamber
Tel:+86-0755-26503290
Fax:+86-0755-26503396

Job No.: JP2017 #230

Standard: EN55015

Test item: Radiation Test

Temp.(C)/Hum.(%) 25 C / 55 %

EUT: Grow Light Reflectors

Mode: ON

Model: Commodore

Manufacturer: MingYu

Polarization: Horizontal

Power Source: AC 230V/50Hz

Date: 18/03/08/

Time: 11/28/02

Engineer Signature: Ben

Distance: 3m

Note: Report NO.:ATE20180312



No.	Freq. (MHz)	Reading (dBuV/m)	Factor (dB)	Result (dBuV/m)	Limit (dBuV/m)	Margin (dB)	Detector	Height (cm)	Degree (deg.)	Remark
1	124.0039	58.85	-27.56	31.29	40.00	-8.71	QP			
2	167.2418	54.66	-26.29	28.37	40.00	-11.63	QP			
3	201.7975	52.68	-24.29	28.39	40.00	-11.61	QP			

7. HARMONIC CURRENT MEASUREMENT

7.1. Block Diagram of Test Setup

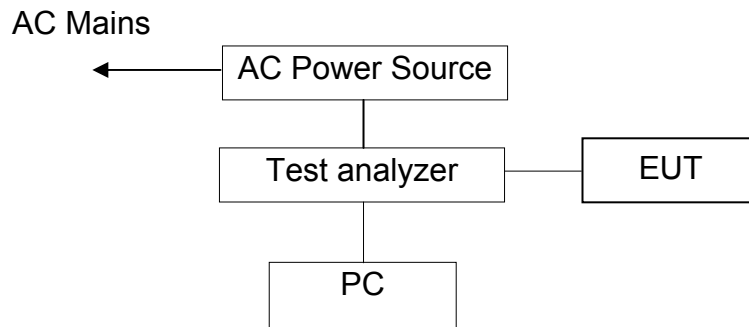

(EUT: Grow Light Reflectors)

7.2. Measuring Standard

EN 61000-3-2: 2014, Class C

7.3. Operating Condition of EUT

7.3.1. Setup the EUT as shown in Section 7.1.

7.3.2. Turn on the power of all equipments.

7.3.3. Let the EUT work in test mode (ON) and measure it.

7.4. Test Results

PASS.

See the following page.

Harmonics – Class-C per Ed. 4.0 (2014)(Run time) incl. inter-harmonics

EUT: Grow Light Reflectors M/N:Commodore Tested by: Ben
 Test category: Class-C per Ed. 4.0 (2014) (European limits) Test Margin: 100
 Test date: 2018/3/9 Start time: 17:02:52 End time: 17:05:33
 Test duration (min): 2.5 Data file name: H-000410.cts_data
 Comment: ON Report NO.:ATE20180312
 Manufacturer: MingYu

Test Result: Pass Source qualification: Normal

Current & voltage waveforms

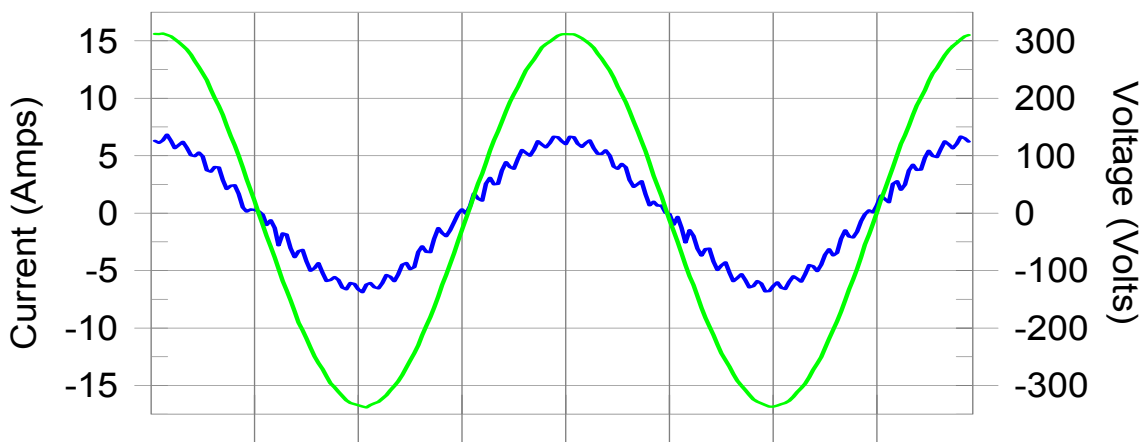

Harmonics and Class C limit line

European Limits

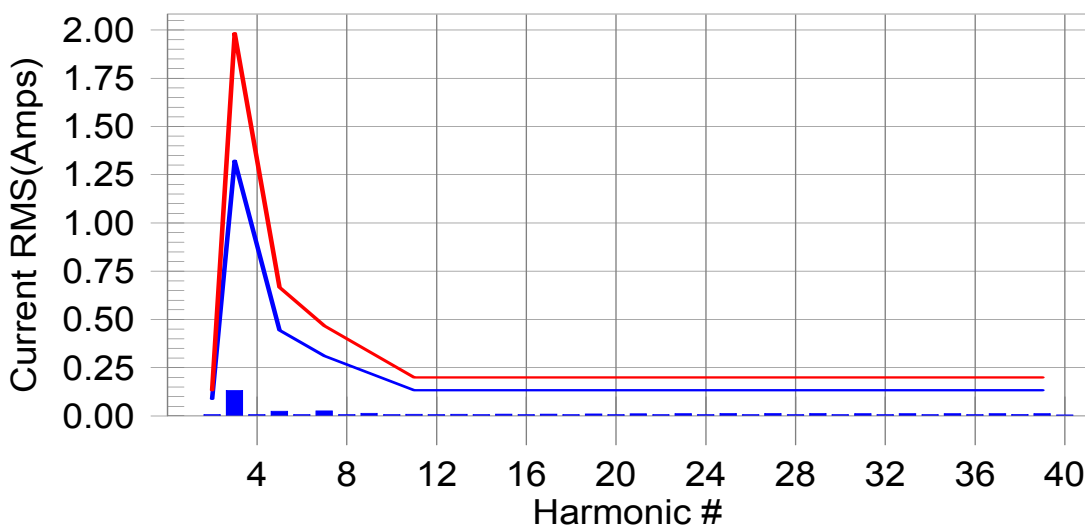

Test result: Pass Worst harmonics H3-6.8% of 150% limit, H3-10% of 100% limit



Current Test Result Summary (Run time)

EUT: Grow Light Reflectors M/N:Commodore Tested by: Ben
 Test category: Class-C per Ed. 4.0 (2014) (European limits) Test Margin: 100
 Test date: 2018/3/9 Start time: 17:02:52 End time: 17:05:33
 Test duration (min): 2.5 Data file name: H-000410.cts_data
 Comment: ON Report NO.:ATE20180312
 Manufacturer: MingYu

Test Result: Pass Source qualification: Normal
 THC(A): 0.149 I-THD(%): 3.3 POHC(A): 0.039 POHC Limit(A): 0.421

Highest parameter values during test:

V_RMS (Volts): 229.83 Frequency(Hz): 50.00
 I_Peak (Amps): 7.185 I_RMS (Amps): 4.465
 I_Fund (Amps): 4.443 Crest Factor: 1.611
 Power (Watts): 1017.9 Power Factor: 0.992

Harm#	Harms(avg)	100%Limit	%of Limit	Harms(max)	150%Limit	%of Limit	Status
2	0.007	0.089	N/A	0.009	0.133	N/A	Pass
3	0.132	1.323	10.0	0.135	1.984	6.8	Pass
4	0.007	0.000	N/A	0.010	0.000	N/A	Pass
5	0.025	0.444	N/A	0.026	0.666	N/A	Pass
6	0.007	0.000	N/A	0.009	0.000	N/A	Pass
7	0.027	0.311	N/A	0.028	0.466	N/A	Pass
8	0.007	0.000	N/A	0.009	0.000	N/A	Pass
9	0.014	0.222	N/A	0.016	0.333	N/A	Pass
10	0.007	0.000	N/A	0.009	0.000	N/A	Pass
11	0.010	0.133	N/A	0.011	0.200	N/A	Pass
12	0.007	0.000	N/A	0.010	0.000	N/A	Pass
13	0.010	0.133	N/A	0.011	0.200	N/A	Pass
14	0.007	0.000	N/A	0.010	0.000	N/A	Pass
15	0.010	0.133	N/A	0.012	0.200	N/A	Pass
16	0.007	0.000	N/A	0.009	0.000	N/A	Pass
17	0.010	0.133	N/A	0.012	0.200	N/A	Pass
18	0.007	0.000	N/A	0.009	0.000	N/A	Pass
19	0.011	0.133	N/A	0.012	0.200	N/A	Pass
20	0.007	0.000	N/A	0.009	0.000	N/A	Pass
21	0.012	0.133	N/A	0.013	0.200	N/A	Pass
22	0.007	0.000	N/A	0.009	0.000	N/A	Pass
23	0.012	0.133	N/A	0.014	0.200	N/A	Pass
24	0.007	0.000	N/A	0.009	0.000	N/A	Pass
25	0.013	0.133	N/A	0.015	0.200	N/A	Pass
26	0.007	0.000	N/A	0.009	0.000	N/A	Pass
27	0.013	0.133	N/A	0.015	0.200	N/A	Pass
28	0.008	0.000	N/A	0.009	0.000	N/A	Pass
29	0.013	0.133	N/A	0.014	0.200	N/A	Pass
30	0.007	0.000	N/A	0.008	0.000	N/A	Pass
31	0.013	0.133	N/A	0.014	0.200	N/A	Pass
32	0.008	0.000	N/A	0.009	0.000	N/A	Pass
33	0.012	0.133	N/A	0.014	0.200	N/A	Pass
34	0.008	0.000	N/A	0.009	0.000	N/A	Pass
35	0.012	0.133	N/A	0.014	0.200	N/A	Pass
36	0.008	0.000	N/A	0.009	0.000	N/A	Pass
37	0.012	0.133	N/A	0.014	0.200	N/A	Pass
38	0.008	0.000	N/A	0.009	0.000	N/A	Pass
39	0.012	0.133	N/A	0.013	0.200	N/A	Pass
40	0.006	0.000	N/A	0.008	0.000	N/A	Pass

Note: Dynamic limits were applied for this test. The highest harmonics values in the above table may not occur at the same window as the maximum harmonics/limit ratio.

Voltage Source Verification Data (Run time)

EUT: Grow Light Reflectors M/N:Commodore Tested by: Ben
 Test category: Class-C per Ed. 4.0 (2014) (European limits) Test Margin: 100
 Test date: 2018/3/9 Start time: 17:02:52 End time: 17:05:33
 Test duration (min): 2.5 Data file name: H-000410.cts_data
 Comment: ON Report NO.:ATE20180312
 Manufacturer: MingYu

Test Result: Pass Source qualification: Normal

Highest parameter values during test:

Voltage (Vrms):	229.83	Frequency(Hz):	50.00
I_Peak (Amps):	7.185	I_RMS (Amps):	4.465
I_Fund (Amps):	4.443	Crest Factor:	1.611
Power (Watts):	1017.9	Power Factor:	0.992

Harm#	Harmonics V-rms	Limit V-rms	% of Limit	Status
2	0.162	0.459	35.26	OK
3	0.632	2.068	30.57	OK
4	0.073	0.460	15.81	OK
5	0.098	0.919	10.69	OK
6	0.071	0.459	15.49	OK
7	0.064	0.689	9.35	OK
8	0.036	0.460	7.73	OK
9	0.034	0.460	7.41	OK
10	0.046	0.460	9.97	OK
11	0.035	0.230	15.19	OK
12	0.027	0.230	11.90	OK
13	0.035	0.230	15.20	OK
14	0.024	0.230	10.27	OK
15	0.028	0.230	12.10	OK
16	0.026	0.230	11.29	OK
17	0.032	0.230	14.13	OK
18	0.024	0.230	10.29	OK
19	0.023	0.230	10.12	OK
20	0.026	0.230	11.48	OK
21	0.023	0.230	10.17	OK
22	0.023	0.230	9.93	OK
23	0.026	0.230	11.36	OK
24	0.019	0.230	8.14	OK
25	0.027	0.230	11.79	OK
26	0.021	0.230	8.96	OK
27	0.026	0.230	11.29	OK
28	0.022	0.230	9.50	OK
29	0.026	0.230	11.48	OK
30	0.018	0.230	7.98	OK
31	0.024	0.230	10.46	OK
32	0.020	0.230	8.67	OK
33	0.022	0.230	9.78	OK
34	0.020	0.230	8.49	OK
35	0.023	0.230	10.06	OK
36	0.019	0.230	8.22	OK
37	0.027	0.230	11.57	OK
38	0.021	0.230	9.31	OK
39	0.027	0.230	11.90	OK
40	0.022	0.230	9.58	OK

8. VOLTAGE FLUCTUATIONS & FLICKER MEASUREMENT

8.1. Block Diagram of Test Setup

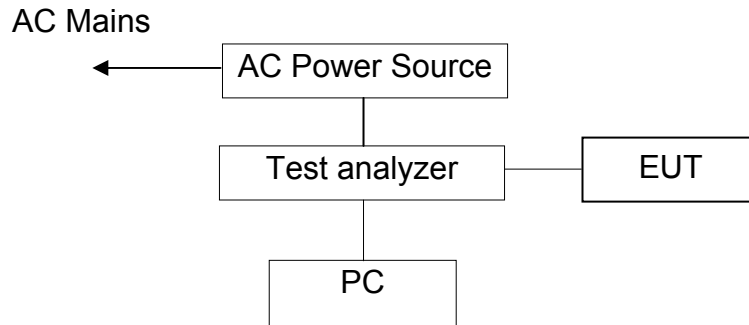

(EUT: Grow Light Reflectors)

8.2. Measuring Standard

EN 61000-3-3: 2013

8.3. Operating Condition of EUT

8.3.1. Setup the EUT as shown in Section 8.1.

8.3.2. Turn on the power of all equipments.

8.3.3. Let the EUT work in test mode (ON) and measure it.

8.4. Test Results

PASS.

See the following page.

Flicker Test Summary per EN/IEC61000-3-3 Ed. 3.0 (2013) (Run time)

EUT: Grow Light Reflectors M/N:Commodore Tested by: Ben
 Test category: All parameters (European limits) Test Margin: 100
 Test date: 2018/3/9 Start time: 17:07:04 End time: 17:17:31
 Test duration (min): 10 Data file name: F-000411.cts_data
 Comment: ON Report NO.:ATE20180312
 Manufacturer: MingYu

Test Result: Pass

Status: Test Completed

Pst_i and limit line

European Limits

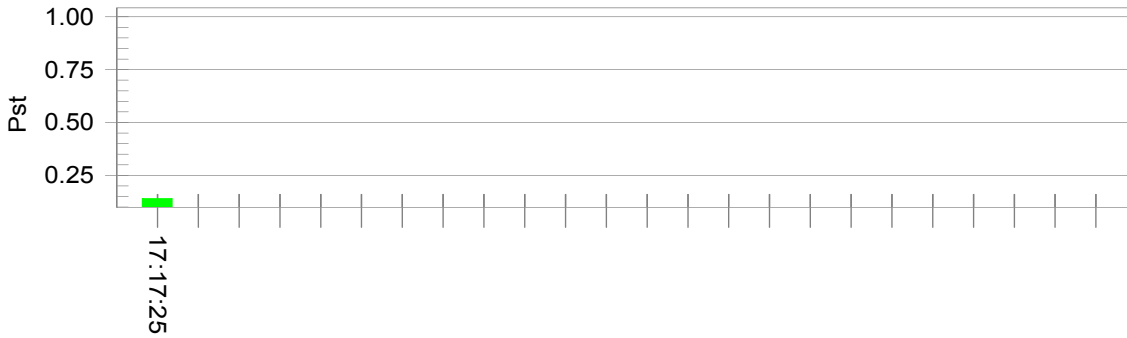

Plt and limit line

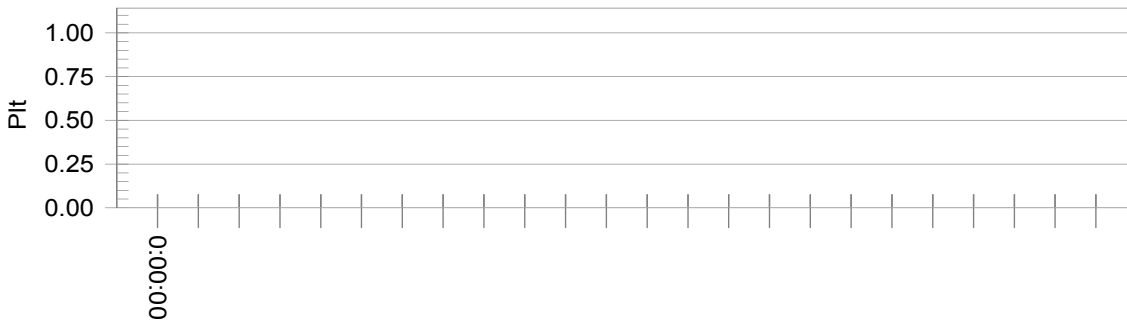

Parameter values recorded during the test:

Vrms at the end of test (Volt):	227.82		
T-max (mS):	0	Test limit (mS):	500.0 Pass
Highest dc (%):	0.00	Test limit (%):	3.30 Pass
Highest dmax (%):	0.00	Test limit (%):	4.00 Pass
Highest Pst (10 min. period):	0.141	Test limit:	1.000 Pass
Highest Plt (2 hr. period):	0.061	Test limit:	0.650 Pass

9. ELECTROSTATIC DISCHARGE TEST

9.1. Block Diagram of Test Setup

9.1.1. Block Diagram of the EUT

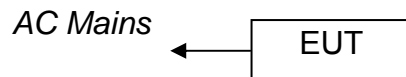

(EUT: Grow Light Reflectors)

9.1.2. Block Diagram of ESD Test Setup

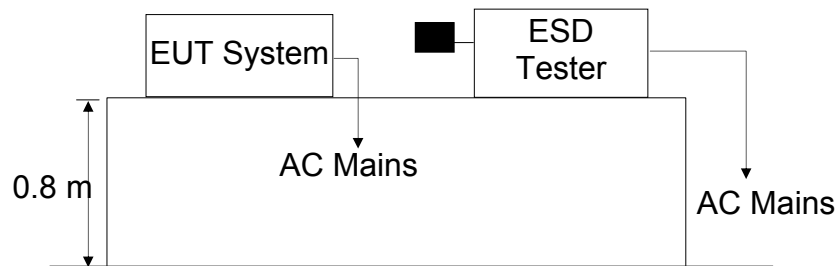

(EUT: Grow Light Reflectors)

9.2. Test Standard

EN 61547: 2009 (IEC61000-4-2: 2008

Severity Level: Air Discharge: Level 3, ± 8 kV, Contact Discharge: Level 2, ± 4 kV)

Testing shall also be satisfied at the lower levels

9.3. Severity Levels and Performance Criterion

9.3.1. Severity level

Level	Test Voltage Contact Discharge (kV)	Test Voltage Air Discharge (kV)
1.	± 2	± 2
2.	± 4	± 4
3.	± 6	± 8
4.	± 8	± 15
X	Special	Special

9.3.2. Performance criterion: **B**

9.4.Manufacturer

The configuration of the EUT is same as Section 4.4.

9.5.Operating Condition of EUT

9.5.1.Setup the EUT as shown in Section 9.1.

9.5.2.Turn on the power of all equipments.

9.5.3.Let the EUT work in test modes (ON) and measure it.

9.6.Test Procedure

9.6.1.Air Discharge:

This test is done on a non-conductive surfaces. The round discharge tip of the discharge electrode shall be approached as fast as possible to touch the EUT. After each discharge, the discharge electrode shall be removed from the EUT. The generator is then re-triggered for a new single discharge and repeated 10 times for each pre-selected test point. This procedure shall be repeated until all the air discharge completed

9.6.2.Contact Discharge:

All the procedure shall be same as Section 9.6.1 except that the tip of the discharge electrode shall touch the EUT before the discharge switch is operated.

9.6.3.Indirect discharge for horizontal coupling plane:

At least 20 single discharges shall be applied to the horizontal coupling plane, at points on each side of the EUT. The discharge electrode positions vertically at a distance of 0.1m from the EUT and with the discharge electrode touching the coupling plane.

9.6.4.Indirect discharge for vertical coupling plane:

At least 20 single discharge shall be applied to the center of one vertical edge of the coupling plane. The coupling plane, of dimensions 0.5m * 0.5m, is placed parallel to, and positioned at a distance of 0.1m from the EUT. Discharges shall be applied to the coupling plane, with this plane in sufficient different positions that the four faces of the EUT are completely illuminated.

9.7.Test Results

PASS.

Please refer to the following page.

Electrostatic Discharge Test Results

Shenzhen Accurate Technology Co., Ltd.

Manufacturer: MingYu Lighting L.T.D.	Test Date : March 8, 2018	
EUT : Grow Light Reflectors	Temperature : 23°C	
M/N : Commodore	Humidity : 50%	
Test Mode : ON	Power Supply: AC 230V/50Hz	
Air Discharge: ± 2kV; ± 4kV; ± 8kV Contact Discharge: ± 2kV; ± 4kV # For each point positive 10 times and negative 10 times discharge		
Location	Kind A-Air Discharge C-Contact Discharge	Result
Non-conductive enclosure	A	PASS
Conductive enclosure	C	PASS
HCP	C	PASS
VCP of the front	C	PASS
VCP of the rear	C	PASS
VCP of the left	C	PASS
VCP of the right	C	PASS
Note:	Test Equipment : ESD Tester (TESEQ, NSG 437)	

Discharge should be considered on Contact and Air and Horizontal Coupling Plane (HCP) and Vertical Coupling Plane (VCP).

10.RF FIELD STRENGTH SUSCEPTIBILITY TEST

10.1.Block Diagram of Test Setup

10.1.1.Block Diagram of the EUT and the simulators

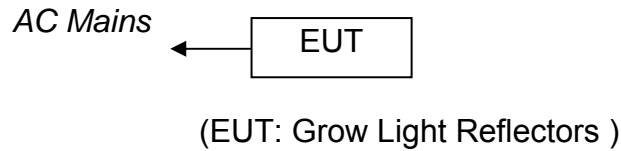

10.1.2.R/S Test Setup

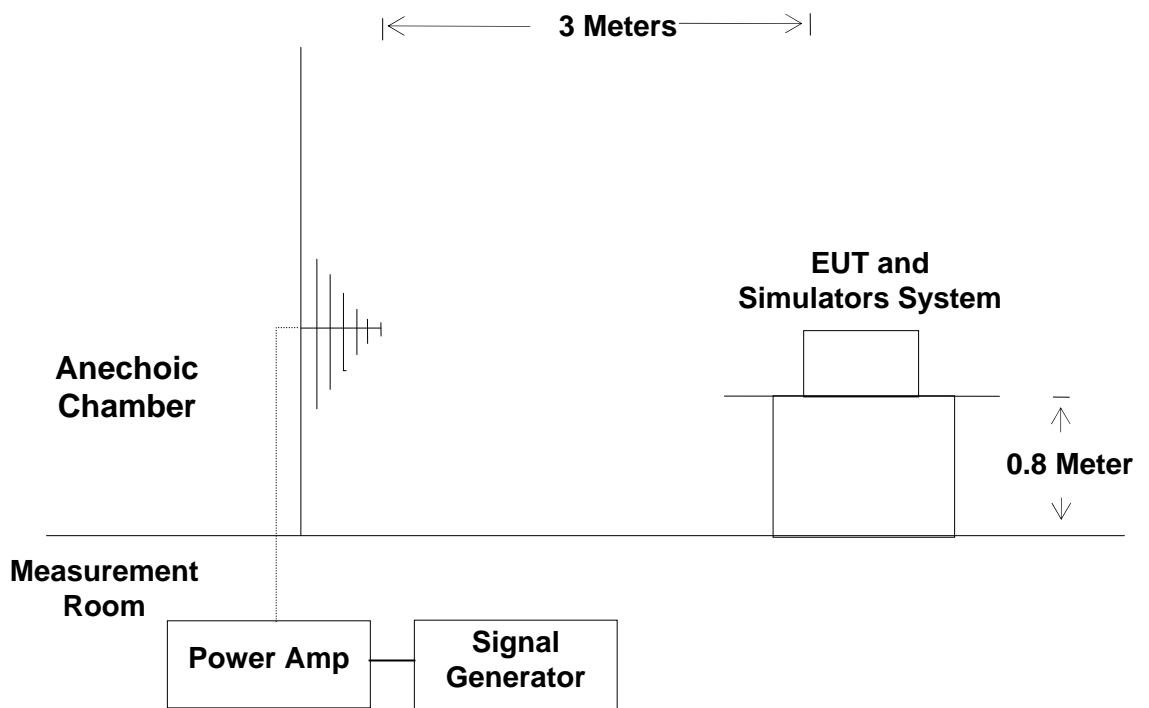

(EUT: Grow Light Reflectors)

10.2.Test Standard

EN 61547: 2009

(IEC61000-4-3: 2006 +A1:2007 +A2:2010, Severity Level: 2, 3V/m)

10.3. Severity Levels and Performance Criterion

10.3.1. Severity level

Level	Field Strength V/m
1.	1
2.	3
3.	10
X	Special

10.3.2. Performance criterion: **A**

10.4. Manufacturer

The configuration of EUT is listed in Section 4.4.

10.5. Operating Condition of EUT

10.5.1. Setup the EUT as shown in Section 10.1.

10.5.2. Turn on the power of all equipments.

10.5.3. Let the EUT work in test mode (ON) and measure it.

10.6. Test Procedure

The EUT and its simulators are placed on a turn table which is 0.8 meter above ground. EUT is set 3 meter away from the transmitting antenna which is mounted on an antenna tower. Both horizontal and vertical polarizations of the antenna are set on test. Each of the four sides of EUT must be faced this transmitting antenna and measured individually. In order to judge the EUT performance, a CCD camera is used to monitor EUT screen.

All the scanning conditions are as follows:

Condition of Test	Remarks
1. Fielded Strength	3 V/m (Severity Level 2)
2. Radiated Signal	Unmodulated
3. Scanning Frequency	80 - 1000 MHz
4. Dwell time of radiated	0.0015 decade/s
5. Waiting Time	1 Sec.

10.7. Test Results

PASS.

Please refer to the following page.

RF Field Strength Susceptibility Test Results

Shenzhen Accurate Technology Co., Ltd.

Manufacturer: MingYu Lighting L.T.D. _____		Test Date: <u>March 8, 2018</u>	
Product: <u>Grow Light Reflectors</u>		Temperature: <u>23°C</u>	
M/N: <u>Commodore</u>		Humidity: <u>50%</u>	
Field Strength: <u>3 V/m</u>		Criterion: <u>A</u>	
Frequency Range: 80 MHz to 1000 MHz		Power Supply: AC 230V/ 50Hz	
Modulation: <input type="checkbox"/> None		<input type="checkbox"/> Pulse	
		<input checked="" type="checkbox"/> AM 1kHz 80%	
Test Mode: ON			
Frequency Range : 80-1000MHz			
Steps 1 %			
		Horizontal	Vertical
Front	PASS		PASS
Right	PASS		PASS
Rear	PASS		PASS
Left	PASS		PASS
Test Equipment : 1. Signal Generator : SMB100A (Rohde & Schwarz) 2. Power Amplifier : MT310A (PRANA) 3. Bilog Antenna : Schwarzbeck (VULB9163)			
Note:			

11.ELECTRICAL FAST TRANSIENT/BURST TEST

11.1.Block Diagram of Test Setup

11.1.1.Block Diagram of the EUT

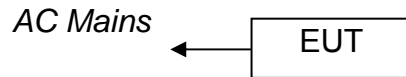

(EUT: Grow Light Reflectors)

11.1.2.For AC Mains

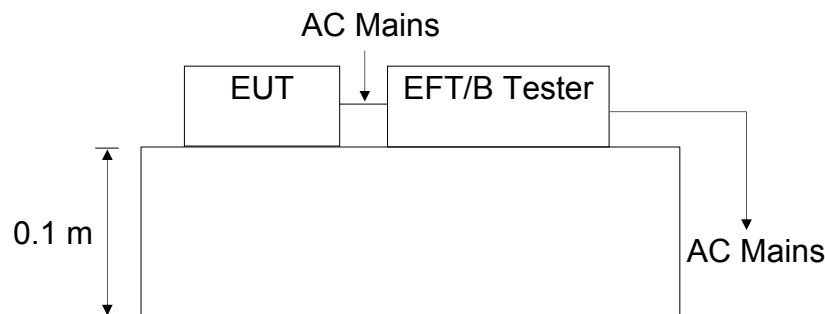

(EUT: Grow Light Reflectors)

11.2.Test Standard

EN 61547: 2009

(IEC61000-4-4: 2012 Severity Level, Level 2: 1kV)

11.3.Severity Levels and Performance Criterion

11.3.1.Severity level

Open Circuit Output Test Voltage $\pm 10\%$		
Level	On Rating Lines	On I/O (Input/Output) Signal data and control lines
1.	0.5 kV	0.25 kV
2.	1 kV	0.5 kV
3.	2 kV	1 kV
4.	4 kV	2 kV
X	Special	Special

11.3.2.Performance criterion: **B**

11.4.Manufacturer

The configuration of EUT is listed in Section 4.4.

11.5. Operating Condition of EUT

Same as Section 4.5 except the test setup replaced by Section 11.1.

11.6. Test Procedure

The EUT is put on the table which is 0.1 meter high above the ground. This reference ground plane shall project beyond the EUT by at least 0.1m on all sides and the minimum distance between EUT and all other conductive structure, except the ground plane beneath the EUT, shall be more than 0.5m.

11.6.1. For input and output AC power ports:

The EUT is connected to the power mains by using a coupling device which couples the EFT interference signal to AC power lines. Both polarities of the test voltage should be applied during compliance test and the duration of the test is 2 mins.

11.6.2. For signal lines and control lines ports:

It's unnecessary to test.

11.6.3. For DC line ports:

It's unnecessary to test.

11.7. Test Result

PASS.

Please refer to the following page.

Electrical Fast Transient/Burst Test Results

Shenzhen Accurate Technology Co., Ltd.

Standard	IEC 61000-4-4: 2012	Result : <input checked="" type="checkbox"/> PASS / <input type="checkbox"/> FAIL	
Manufacturer: MingYu Lighting L.T.D. EUT: <u>Grow Light Reflectors</u> M/N : <u>Commodore</u> Power Supply : <u>AC 230V/ 50Hz</u> Test Mode : <u>ON</u>		Test Date: <u>March 8, 2018</u> Temperature : <u>25°C</u> Humidity: <u>50%</u> Test Engineer : <u>Frank</u> Criterion : <u>B</u>	
Line : <input checked="" type="checkbox"/> AC Mains		Line : <input type="checkbox"/> Signal Line <input type="checkbox"/> DC Output Line	
Coupling : <input checked="" type="checkbox"/> Direct		Coupling : <input type="checkbox"/> Capacitive	
Test Time : 120s			
Line	Test Voltage	Result(+)	Result(-)
L, N	1kV	PASS	PASS
L, N, PE	1kV	PASS	PASS
Note :			
Test Equipment		Burst Tester Model : ULTRA COMPACT SIMULATOR: UCS 500 N5 (EM TEST) CAPACITIVE CLAMP: HFK (EM TEST) Transformer: V4780S2 (EM TEST)	

12.SURGE IMMUNITY TEST

12.1.Block Diagram of Test Setup

12.1.1.Block Diagram of the EUT

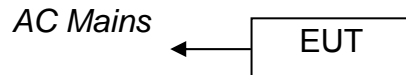

(EUT: Grow Light Reflectors)

12.1.2.Block Diagram of the Surge Test Setup

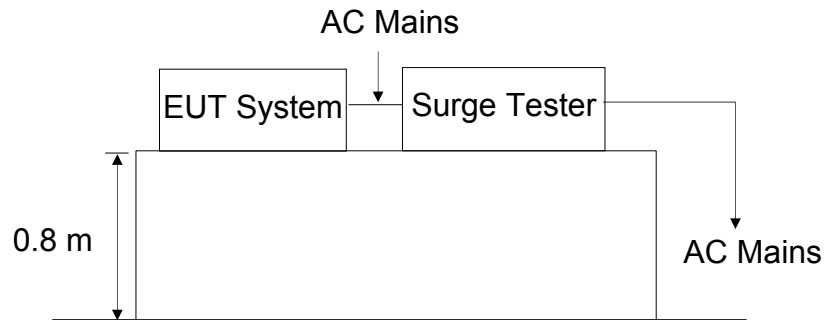

(EUT: Grow Light Reflectors)

12.2.Test Standard

EN 61547: 2009

(IEC61000-4-5: 2014 +A1:2017, Severity Level: Level 2, 1.0 kV)

Testing shall also be satisfied at the lower levels

12.3.Severity Levels and Performance Criterion

12.3.1.Severity level

Severity Level	Open-Circuit Test Voltage kV
1	0.5
2	1.0
3	2.0
4	4.0
*	Special

12.3.2. Performance criterion: **C**

12.4.Manufacturer

The configuration of EUT is listed in Section 4.4.

12.5.Operating Condition of EUT

Same as Section 4.5 except the test setup replaced by Section 12.1.

12.6.Test Procedure

- 1) Set up the EUT and test generator as shown on Section 12.1.2.
- 2) For line to line coupling mode, provide a 1.0kV 1.2/50 μ s voltage surge (at open-circuit condition) and 8/20 μ s current surge to EUT selected points.
- 3) At least 5 positive and 5 negative (polarity) tests with a maximum 1/min repetition rate are conducted during test.
- 4) Different phase angles are done individually.
- 5) Record the EUT operating situation during compliance test and decide the EUT immunity criterion for above each test.

12.7.Test Result

PASS.

Please refer to the following page.

Surge Immunity Test Results

Shenzhen Accurate Technology Co., Ltd.

Manufacturer : MingYu Lighting L.T.D. _____ EUT : <u>Grow Light Reflectors</u> M/N : <u>Commodore</u> Power Supply : <u>AC 230V/ 50Hz</u> Criterion : <u>C</u>				Test Date: <u>March 8, 2018</u> Temperature : <u>23°C</u> Humidity : <u>50%</u> Test Engineer : <u>Frank</u> Test Mode: <u>ON</u>	
Location	Polarity	Phase Angle	No. of Pulse	Pulse Voltage (kV)	Result
L-N	+	90 ⁰	5	1.0	PASS
	-	270 ⁰	5	1.0	PASS
L-PE	+	90 ⁰	5	2.0	PASS
	-	270 ⁰	5	2.0	PASS
N-PE	+	90 ⁰	5	2.0	PASS
	-	270 ⁰	5	2.0	PASS
Remark:				Test Equipment : ULTRA COMPACT SIMULATOR: UCS 500 N5 (EM TEST) Transformer: V4780S2 (EM TEST)	

13.INJECTED CURRENTS SUSCEPTIBILITY TEST

13.1.Block Diagram of Test Setup

13.1.1.Block Diagram of the EUT

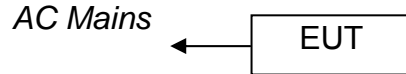

(EUT: Grow Light Reflectors)

13.1.2.Block Diagram of AC Mains

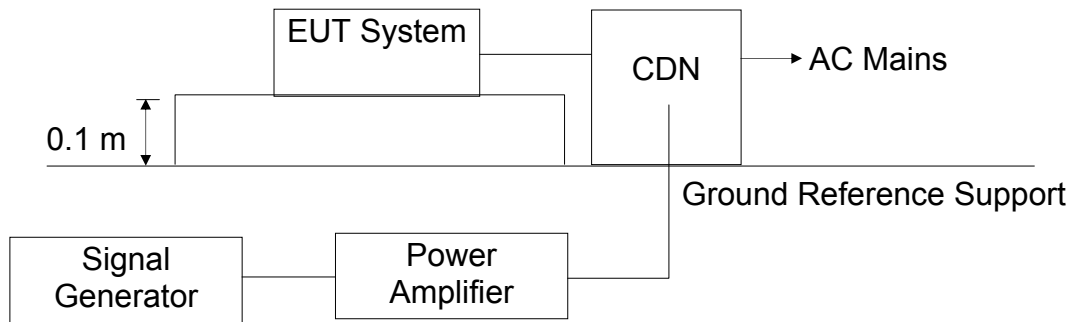

(EUT: Grow Light Reflectors)

13.2.Test Standard

EN 61547: 2009(IEC61000-4-6: 2013,
Severity Level: 3V (rms), 0.15MHz - 80MHz)

13.3.Severity Levels and Performance Criterion

13.3.1.Severity level

Level	Field Strength V
1.	1
2.	3
3.	10
X	Special

13.3.2.Performance criterion: **A**

13.4.Manufacturer

The configuration of EUT is listed in Section 4.4.

13.5.Operating Condition of EUT

Same as Section 4.5 except the test setup replaced by Section 13.1.

13.6.Test Procedure

- 1) Set up the EUT, CDN and test generators as shown on Section 13.1.2.
- 2) Let the EUT work in test mode and measure it.
- 3) The EUT are placed on an insulating support 0.1m high above a ground reference plane. CDN (coupling and decoupling device) is placed on the ground plane about 0.3m from EUT. Cables between CDN and EUT are as short as possible, and their height above the ground reference plane shall be between 30 and 50 mm (where possible).
- 4) The disturbance signal described below is injected to EUT through CDN.
- 5) The EUT operates within its operational mode(s) under intended climatic conditions after power on.
- 6) The frequency range is swept from 150 kHz to 80MHz using 3V signal level, and with the disturbance signal 80% amplitude modulated with a 1 kHz sine wave.
- 7) The rate of sweep shall not exceed 1.5×10^{-3} decades/s. Where the frequency is swept incrementally; the step size shall not exceed 1% of the front and thereafter 1% of the preceding frequency value.
- 8) Recording the EUT operating situation during compliance testing and decide the EUT immunity criterion.

13.7.Test Results

PASS.

Please refer to the following page.

Injected Currents Susceptibility Test Results

Shenzhen Accurate Technology Co., Ltd.

Manufacturer : MingYu Lighting L.T.D. <hr style="width: 50%; margin-left: 0;"/>			Test Date : <u>March 8, 2018</u>	
EUT : <u>Grow Light Reflectors</u>			Temperature : <u>23°C</u>	
M/N : <u>Commodore</u>			Humidity : <u>50%</u>	
Power Supply : <u>AC 230V/ 50Hz</u>			Test Engineer : <u>Frank</u>	
Test Mode: ON				
Frequency Range (MHz)	Injected Position	Strength	Criterion	Result
0.15 - 80	AC Mains	3V(rms)	A	PASS
0.15 - 80	DC Line	3V(rms)	A	PASS
Remark : 1. Modulation Signal:1kHz 80% AM Measurement Equipment : Conducted Immunity Test System: CIT-10 (FRANKONIA) CDN : CDN-M2/3 (FRANKONIA) EM Injection Clamp: F-203I-23mm (FCC) Calibration Fixture: F-203I-23mm-CF (FCC)			Note:	

14.MAGNETIC FIELD IMMUNITY TEST

14.1.Block Diagram of Test Setup

14.1.1.Block Diagram of the EUT

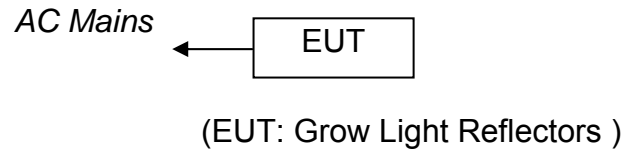

14.1.2.Block Diagram of Test Setup

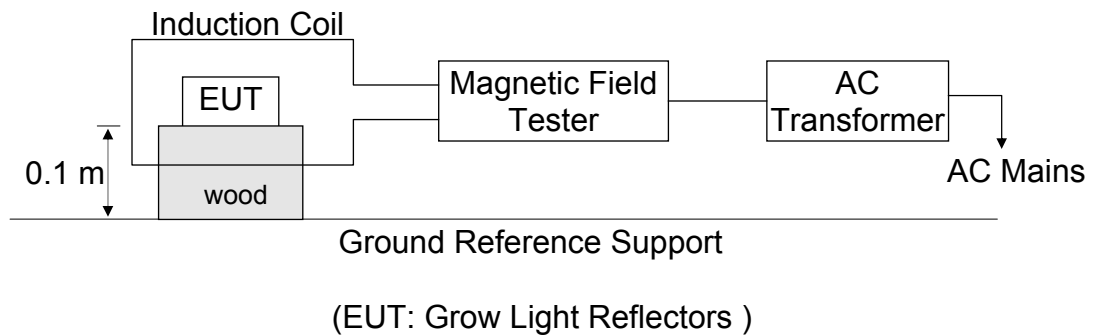

14.2.Test Standard

EN 61547: 2009
(IEC61000-4-8: 2009, Severity Level 2: 3A/m)

14.3.Severity Levels and Performance Criterion

14.3.1.Severity level

Level	Magnetic Field Strength A/m
1.	1
2.	3
3.	10
4.	30
5.	100
X	Special

14.3.2.Performance criterion: A

14.4.Manufacturer

The configuration of EUT is listed in Section 4.4.

14.5.Operating Condition of EUT

Same as Section 4.5 except the test setup replaced by Section 14.1.

14.6.Test Procedure

- 1) Set up the EUT system as shown on Section 14.1.2.
- 2) The Induction coil is set up in horizontal or vertical.
- 3) Let the EUT work in test mode and measure it.

14.7.Test Results

PASS.

Please refer to the following page.

Magnetic Field Immunity Test Results

Shenzhen Accurate Technology Co., Ltd.

Manufacturer : MingYu Lighting L.T.D. _____ EUT : Grow Light Reflectors _____ M/N : Commodore _____ Power Supply : AC 230V/ 50Hz _____			Test Date : March 8, 2018 _____ Temperature : 23°C _____ Humidity : 50% _____ Test Engineer: Frank _____	
Test Mode: ON				
Test Level	Testing Duration	Coil Orientation	Criterion	Result
3A/m	5 mins	Horizontal	A	PASS
3A/m	5 mins	Vertical	A	PASS
Remark:			Test Equipment: Magnetic Field Tester MAG100 AC Transformer TDGC2J-5	

15.VOLTAGE DIPS AND INTERRUPTIONS TEST

15.1.Block Diagram of Test Setup

15.1.1.Block Diagram of the EUT

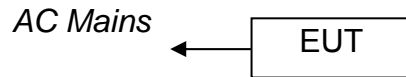

(EUT: Grow Light Reflectors)

15.1.2.Dips Test Setup

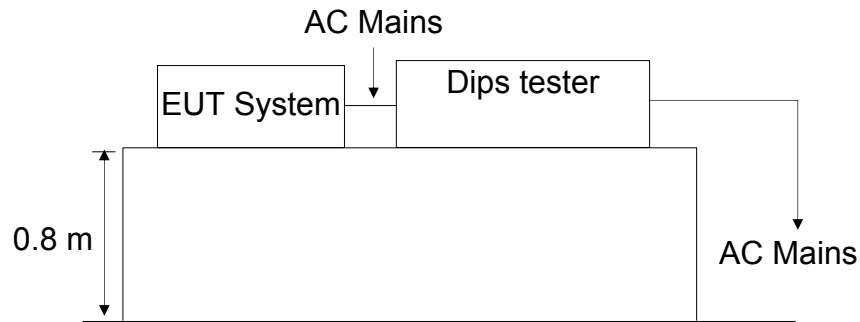

(EUT: Grow Light Reflectors)

15.2.Test Standard

EN 61547: 2009 (IEC61000-4-11: 2004 +A1:2017)

15.3.Severity Levels and Performance Criterion

15.3.1.Severity level

Test Level $\%U_T$	Voltage dip and short interruptions $\%U_T$	Duration (in period)
0	100	0.5 1
40	60	5 10 25
70	30	50 *

15.3.2.Performance criterion: **B&C**

15.4.Manufacturer

The configuration of EUT is listed in Section 4.4.

15.5.Operating Condition of EUT

Same as Section 4.5 except the test setup replaced by Section 15.1.

15.6.Test Procedure

- 1) Set up the EUT and test generator as shown on Section 15.1.2.
- 2) The interruption is introduced at selected phase angles with specified duration.
- 3) Record any degradation of performance.

15.7.Test Result

PASS.

Please refer to the following page.

Voltage Dips And Interruptions Test Results

Shenzhen Accurate Technology Co., Ltd.

Manufacturer : MingYu Lighting L.T.D. EUT : <u>Grow Light Reflectors</u> M/N : <u>Commodore</u> Power Supply : <u>AC 230V/ 50Hz</u>			Test Date : <u>March 8, 2018</u> Temperature : <u>23°C</u> Humidity : <u>50%</u> Test Engineer : <u>Frank</u>	
Test Mode : ON				
Test Level % U _T	Voltage Dips & Short Interruptions % U _T	Duration (in period)	Criterion <input type="checkbox"/> A <input checked="" type="checkbox"/> B <input checked="" type="checkbox"/> C <input type="checkbox"/> D	Result
70	30	10P	C	PASS
0	100	0.5P	B	PASS
Remark: U _T is the rated voltage for the equipment.			Test Equipment : ULTRA COMPACT SIMULATOR: UCS 500 N5 (EM TEST) Transformer: V4780S2 (EM TEST)	

16.PHOTOGRAPH

16.1.Photo of Conducted Emission Measurement



16.2.Photo of Magnetic field Emission Measurement



16.3.Photo of Radiated Measurement

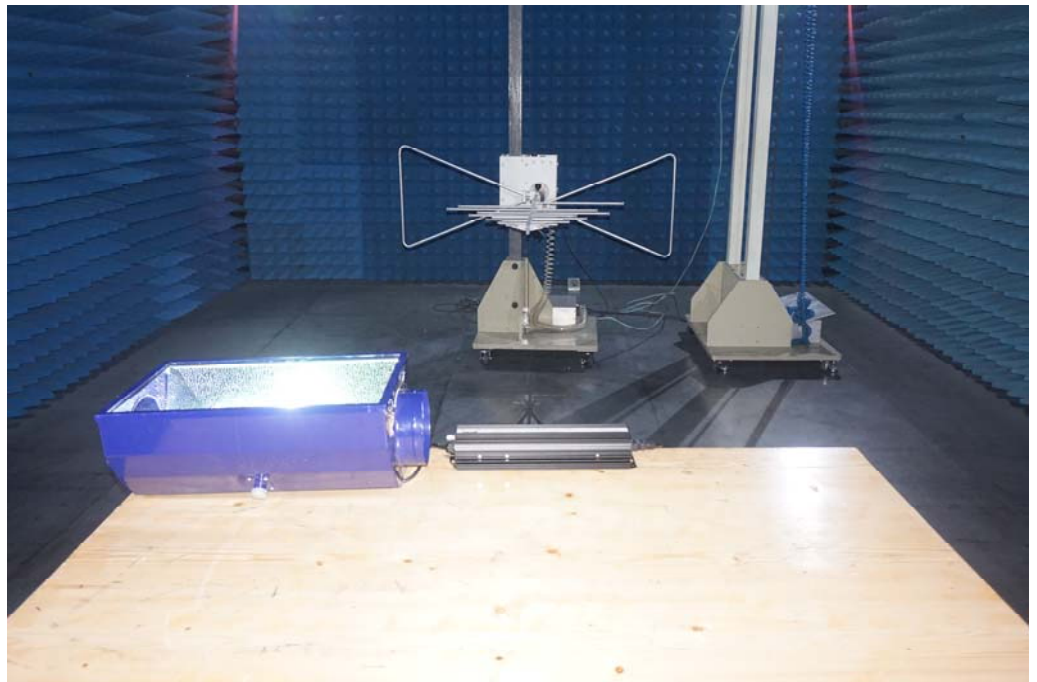

16.4.Photo of Harmonic Current / Flicker Measurement



16.5.Photo of Electrostatic Discharge Test



16.6.Photo of RF Field Strength Susceptibility Test

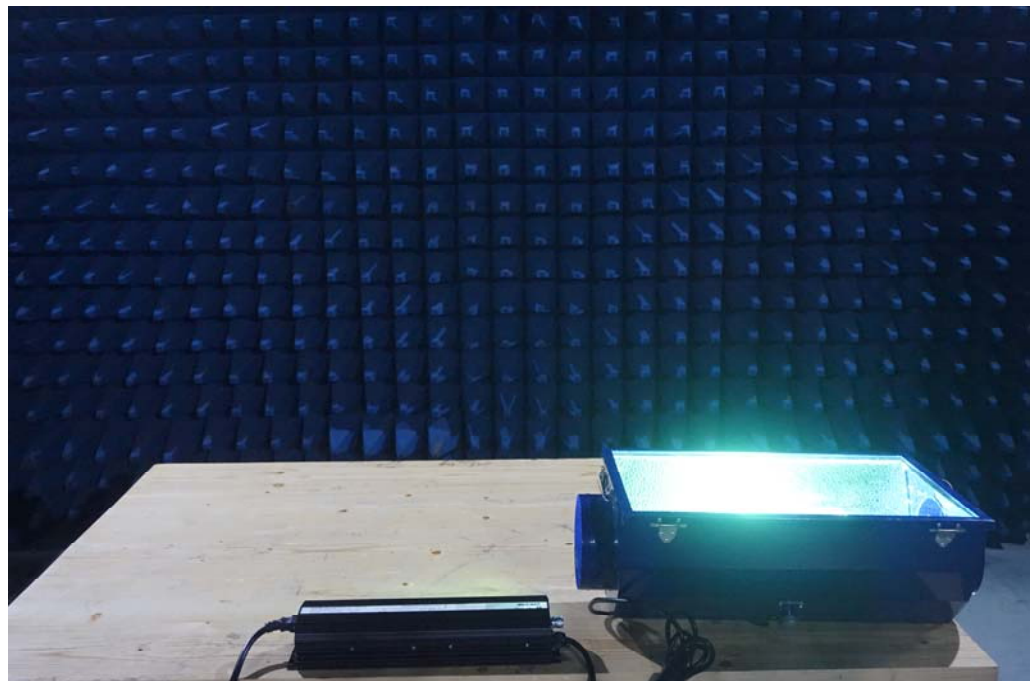

16.7. Photo of Electrical Fast Transient /Burst Test



16.8. Photo of Surge and Voltage Dips and Interruption Immunity Test

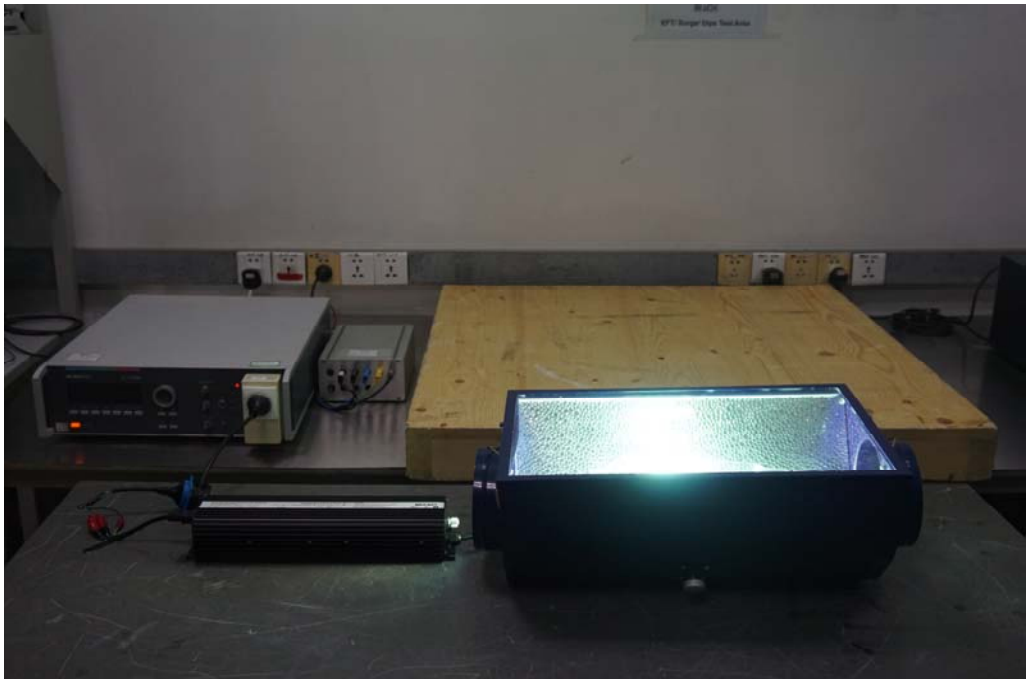

16.9. Photo of Injected Current Susceptibility Test



16.10. Photo of Magnetic Field Susceptibility Test



16.11.Photo of EUT



