

Installation Directions

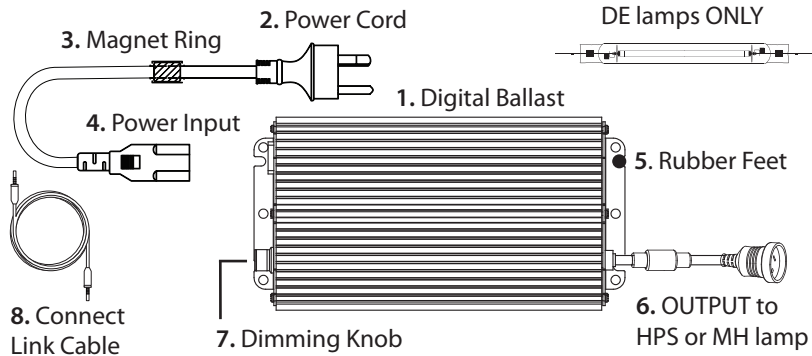

STATUS	LED
Output lock down	1 Flash
Output errors	2 Flash
Low input voltage	3 Flash
Over temperature	4 Flash
High input	5 Flash

BOX CONTENT:
 1 x 1000w Digital Ballast
 1 x Power Cord
 1 x Connect Link Cable
 4 x Rubber Feet
 1 x User Manual

Note: When the controller is connected the CONTROL indicator LED flashes 2 times every 2 seconds - indicating controller is functioning correctly. However, if the Connect Link Cable is removed during operation the ballast will shut down after 3 minutes. When operating ballast without a HI-PAR Control Station the CONTROL indicator LED will be off. Turn power off and on to reset the ballast when either connecting or disconnecting the Control Station.

MAINS POWER	MIN	MAX
BOOST	1116	1185
100%	1016	1085
75%	761	830
60%	602	671

Units = Watts

LAMP POWER	MIN	MAX
BOOST	1066	1135
100%	966	1035
75%	716	785
60%	566	635

Units = Watts

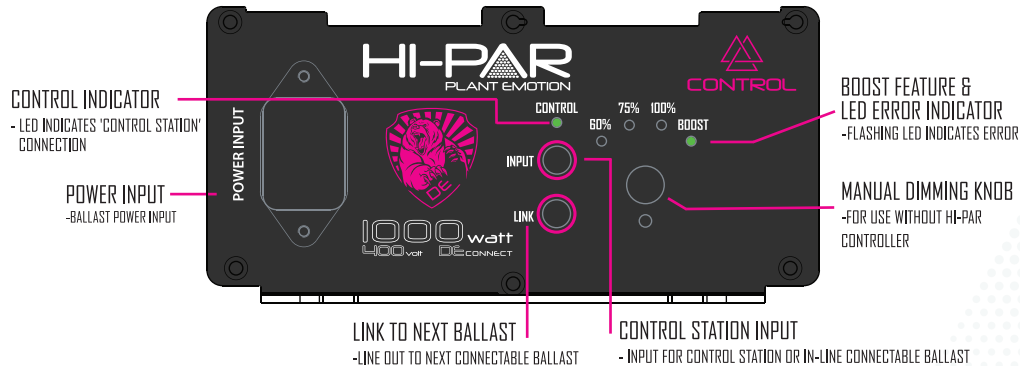

HI-PAR™
PLANT EMOTION

1000watt

1000W CONTROLLABLE BALLAST

USER MANUAL



HP1000E Control for DE HPS and MH lamps

Data is based on operation of a standard double ended HPS/MH lamp. Supply power is based on typical commercial 240V,50/60Hz.

Performance

Model	Model Voltage (V)	Max Input Power (W)	THD	Maximum Current (A)	Power Factor (COSθ)	Working Voltage (V)	Ignitor Voltage (kV)
HP1000E Control	240V	1185	<10%	5.0	.97	215-265	4.0



WWW.HI-PAR-HORTICULTURE.COM



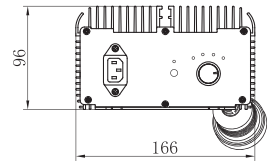
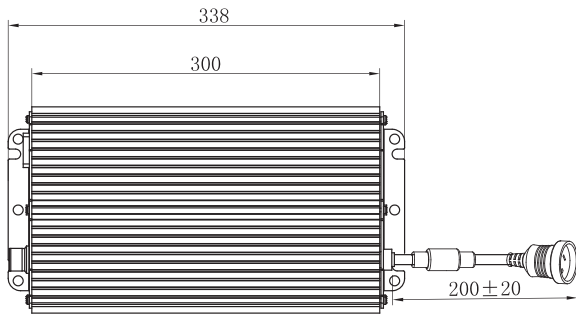

Model	Length (mm)	Width (mm)	High (mm)	Colour	Material	Weight (kgs)
HP1000E Control	338	166	96	Black	Aluminium	4.0

Connecting the Ballast

- Please refer to the included wiring diagram for proper wiring connection.
- Only use the provided cables to connect the ballast to the power supply/socket.
- Insert recommended HPS/MH lamp into lamp socket.
- Ensure lamp type is correct orientation.
- Do not use an external ignitor.
- Lamps with auto-ignitor will not work with the digital ballast.
- Connect the ballast into the Hi-PAR Control Station.

Ignitor Safe Protection

The Digital Ballast will ignite automatically. During this period, the ballast can protect itself without manual intervention. If HPS lamp does not work after 5 minutes (For MH, at most 15 min), please check the connection or change the lamp.

User Guide

This product must be equipped with the right High Pressure Sodium lamp (HPS) or Metal Halide lamp (MH) to get the highest efficiency, safety, and luminance output from the lamp.

WARNING: This manual contains important safety that should be followed during the installation and maintenance of the product. Please read this manual thoroughly before attempting to install or operate this product.

1. Before any assembly or maintenance, make sure the power supply is turned off.
2. To ensure safe system operation, only use certified light shades, cords, and lamp sockets which match a national or international safety standard.
3. Lamp must be operated a distance away from any flammable substance.
4. Do not cover the digital ballast without proper heat sinking; doing so may affect the normal case temperature (tc) of the digital ballast. Improper heat dissipation may shorten ballast life and void the warranty. tc=70oC/158oF.
5. Product is for indoor/enclosed use only; it must be protected from water/liquids.
6. Ensure proper mounting and installation of the digital ballast; it must be securely fastened to a fixed substrate to protect it from detachment, impact and excessive vibrations. If not secured, damage to the unit or persons may result.
7. Please ensure the input power matches with the specifications of the digital Ballast. If you are not clear about the electrical source, please contact your power utility company, an electrician or your local distributor.
8. Install the power cord so it can not be pinched, stepped on or tripped over; secure cord and digital ballast properly to avoid lighting interruptions/hazards.
9. If the power cord needs to be extended, please make sure it meets the standard electrical safety requirement; the wire diameter should be at least 1.5mm² or 16AWG. Not following electrical code may result in fire or other accidents.
10. To avoid the risk of shock or fire, and as to not void the Warranty, do not open or disassemble the digital ballast.
11. If you have any questions on the installation of the digital ballast, or should you experience any trouble please contact your local authorised HI-PAR dealer.

CONTROL STATION Compatible - Plug and Play **Linkable 400 Fixture - 200 Ballast on each channel**

Connecting the Ballast to the HI-PAR 'Control Station' (controller - sold separately)

- Control Station communicates with ballast via TRS (Stereo) cable
- Multiple ballasts can be installed in 'daisy-chain' arrangement
- Up to 200 Ballasts per zone, two zones per Control Station
- Control Station and Thermo Sensors regulate timing and dimming control

