



Our Pouf provides a plush, comfortable extra seat and a playful accent for the bedroom or playroom. It also serves as a comfortable footrest for our Nash Swivel Glider.

#### FRAME CONSTRUCTION

##### POLY:

All of the foam used in our pieces is CertiPUR-US® certified. None of the foam used in our products contain flame retardants. All of our products are TBI 17-2013 compliant

---

#### QUESTIONS?

HELLO@COLEYHOME.COM

980.237.9861

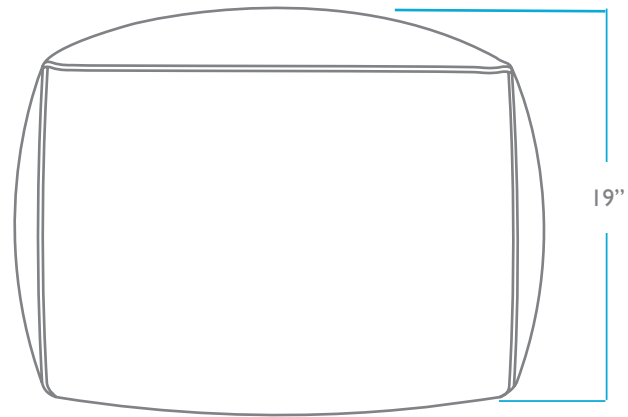
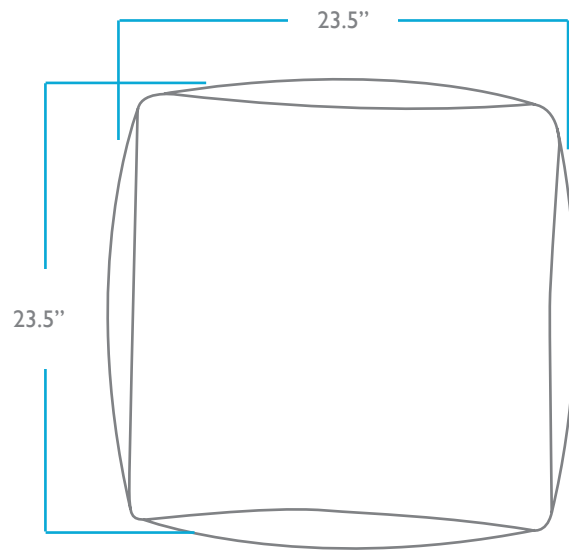

**OVERALL**  
HEIGHT: 19"  
DEPTH: 23.5"

**PACK WEIGHT**  
20 LBS