



DESIGN BY  
NICOLA BATHIE MCLAUGHLIN

Maximizing comfort and coziness, the Bryant Sectional is available in several configurations to perfectly fit your needs. Featuring a sleek bench seat and upholstered legs, the Bryant Sectional will be the ultimate destination for lounging.

#### FRAME CONSTRUCTION

##### WOOD:

Responsibly harvested engineered hardwood with interlocking glued joints that are corner blocked for durability

##### SPRINGS:

Heavy gauge wire sinuous springs made of 80% recycled metal

##### POLY:

All of the foam used in our pieces is CertiPUR-US® certified. None of the foam used in our products contain flame retardants. All of our products are TB117-2013 compliant

#### CUSHION CONTENT

##### BACK CUSHION:

Our Plush Back Cushions are made of 100% microfiber. This high end fill provides a resilient back which will help your cushions keep their shape over time. Plush fill is also hypoallergenic and environmentally friendly.

##### SEAT CUSHION:

Seat cushions feature a high-resilient foam core that is wrapped in a fiber-down blend and sewn into a down-proof ticking.

---

#### QUESTIONS?

HELLO@COLEYHOME.COM

980.237.9861

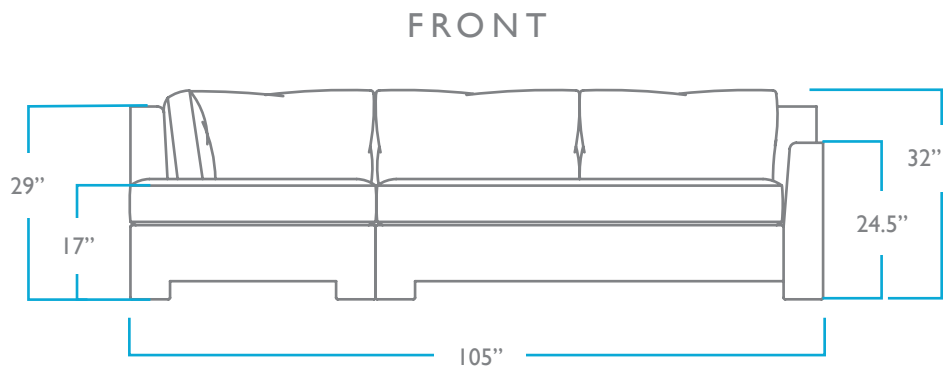
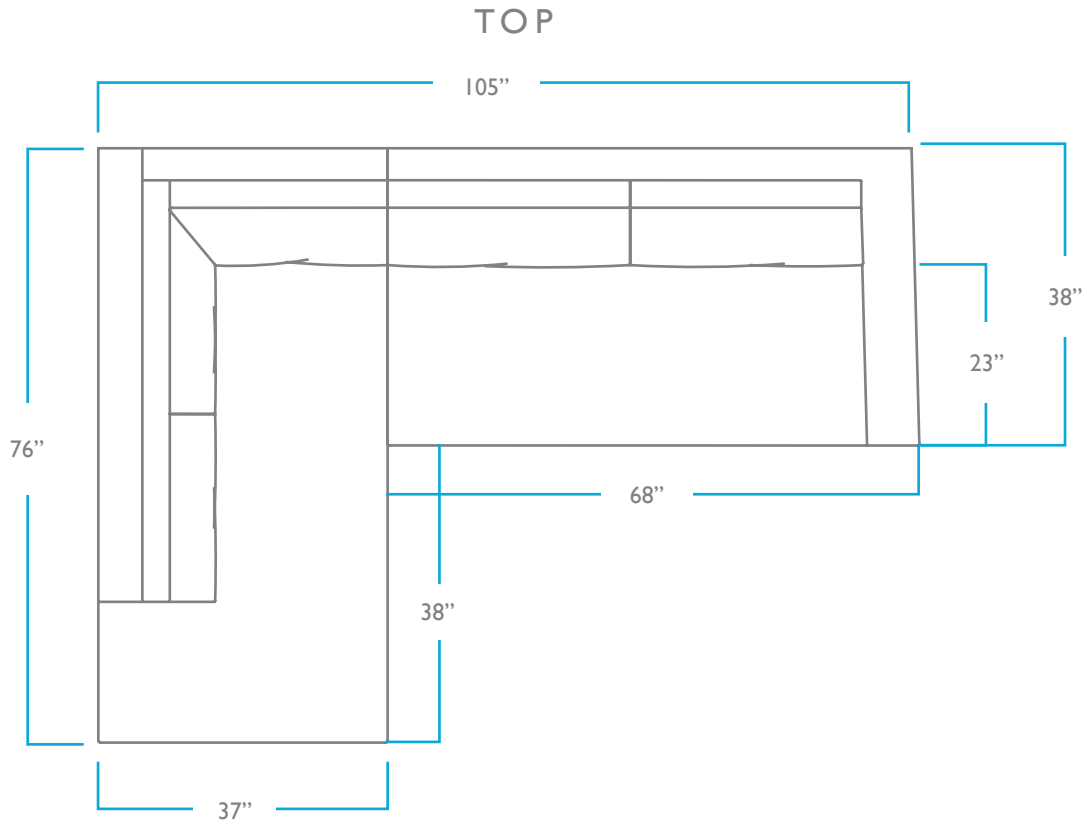

**OVERALL**

HEIGHT: 32"

WIDTH: 105"

CHAISE LENGTH: 76"

DEPTH: 38"

**SEAT**

HEIGHT: 17"

DEPTH: 23"

**PACK WEIGHT**

315 LBS