



An updated sectional perfect for the entertainer, a family, or anyone needing a little more seating. We created a piece that could be equally as sleek as comfortable. With a beautiful saber arm and soft cushions, this will be your new spot. Kick up your feet!

FRAME CONSTRUCTION

WOOD:

Responsibly harvested engineered hardwood with interlocking glued joints that are corner blocked for durability

SPRINGS:

Heavy gauge wire sinuous springs made of 80% recycled metal

POLY:

All of the foam used in our pieces is CertiPUR-US® certified. None of the foam used in our products contain flame retardants. All of our products are TB117-2013 compliant

CUSHION CONTENT

BACK CUSHION:

Our Plush Back Cushions are made of 100% microfiber. This high end fill provides a resilient back which will help your cushions keep their shape over time. Plush fill is also hypoallergenic and environmentally friendly.

SEAT CUSHION:

Seat cushions feature a high-resilient foam core that is wrapped in a fiber-down blend and sewn into a down-proof ticking.

AVAILABLE CUSTOMIZATIONS

SLIPCOVERED

OR UPHOLSTERED

WOOD FINISHES



WALNUT



WEATHERED
OAK



SIMPLY
WHITE



NATURAL



DUNE

QUESTIONS?

HELLO@COLEYHOME.COM

980.237.9861

TOP

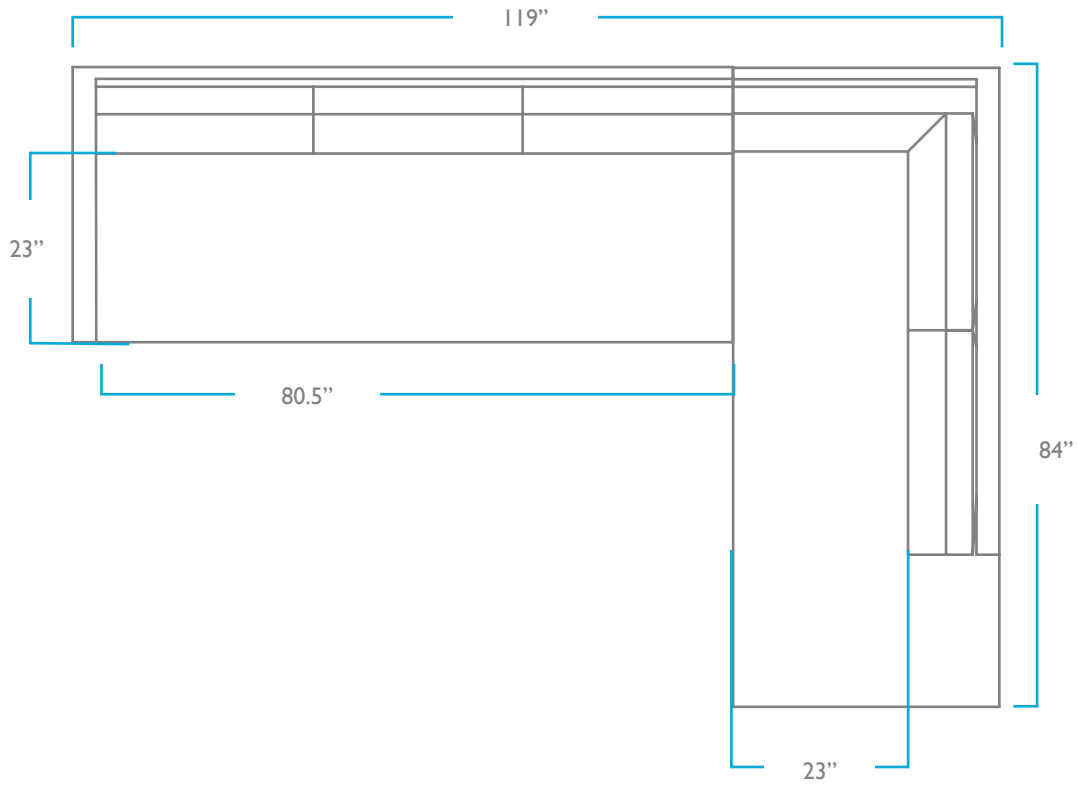

SIDE

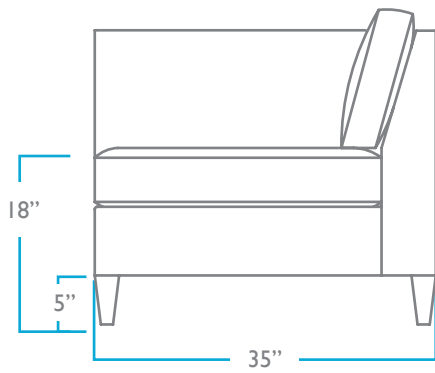

SIDE

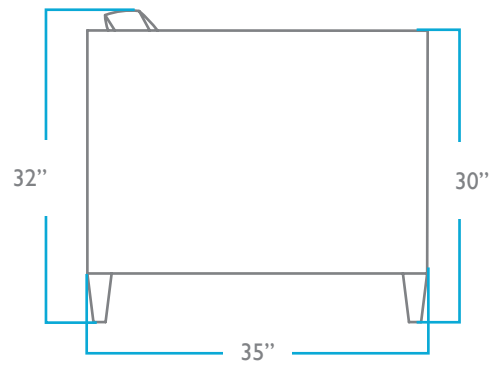

OVERALL

HEIGHT: 32"

WIDTH: 119"

CHAISE LENGTH: 84"

DEPTH: 35"

SEAT

HEIGHT: 18"

DEPTH: 23"

PACK WEIGHT

330 LBS