



TEKQUEST
INDUSTRIES

Model CA-90 Bathroom Ductless Fan Motor Mount Assembly Specifications

*Thank you for keeping your
CA -90 Ductless Fan in good working
condition.*

Motor mount assembly consists of:

1. Motor
2. Fan blade
3. Motor mount
4. Male plug



Inside the Ductless Fan

Complete Unit consists of:

- A. Motor Mount Assembly (motor, fan blade, motor mount and male plug)
- B. Louver - 5-5/8" X 11 15/16" X 3/4"
- C. Cartridge Filter - 3" X 3"
- D. Metal Housing - 4" X 3 7/16" X 10"
- E. Cover plate
- F. Receptacle
- G. 2 Large Screws and 2 small screws.

On the picture to the right, you are able to see inside the complete unit. This demonstrates the fan assembly installed. The 2 small screws are the only attachment required for installation to the housing. The top of the motor mount sits level with the metal housing can.



RUSH HAMPTON™

DUCTLESS BATHROOM
DEODORIZER
MODEL CA-90

INSTRUCTIONS & SPECIFICATIONS

1. Housing Dimension: 4'X3 7/16"X 10"
(see drawing)
2. Packaging: Bulk packed, 12 units to a carton or single pack
Pack "A" includes housing, female plug instructions.
Pack "B" includes grill, filter, motor assembly & 2 screws
3. Voltage: Unit operates on standard 120 volt house current.
4. Motor: 1/250 HP, 2800 RPM, 23 watts, 0.285 amps.
5. Unit is UL listed.
6. Grill: Attached by a single screw in each end. Made of high-impact plastic. Available in beige and white. 5 5/8" X 11 15/16" X 3/4" (see drawing)

FILTER REPLACEMENT

The unit contains one replaceable CA-90 filter casing made of high-impact plastic. The CA-90 Deodorizer filter is easily replaced without removing the grill (see drawing).

For best results the CA-90 filter should be replaced every six months or more frequently as needed.

Replacement CA-90 filters are available from **RUSH HAMPTON™ Customer Service Department 1-800-327-7175 or @ rushhampton.com.**

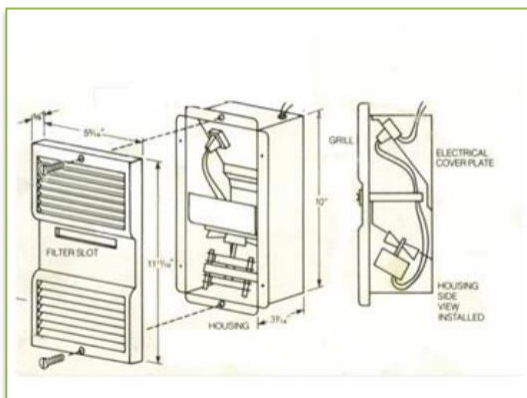

MAINTENANCE

Easy to care for; just wipe the grill face with a damp cloth. To clean the inside of the unit, remove the screws in the grill face, remove the grill from the housing, and unplug the fan motor before cleaning. Use a soft brush (such as an along-handled paint brush) to clean the motor and motor housing, or use a vacuum cleaner to remove dust and debris from the interior of the unit. Do not use harsh detergents. Unplug the Fan motor before cleaning.

INSTALLATION

1. Unit is intended for ceiling mount
2. If wallboard is installed before "rough-in", see unit dimensions (on the front page) for opening size.
3. Unit can be attached directly to joists.
4. Wiring: 120 volt. Plug –in fan for easy hookup

WARNING – TO REDUCE THE RISK OF FIRE ELECTRIC SHOCK OR INJURY TO PERSONS OBSERVE THE FOLLOWING:

- A. Installation work and Electrical Wiring must be done by qualified persons in accordance with all applicable codes and standards, included Fire- rated Construction.
- B. When cutting or drilling into ceiling, do not damage electrical wiring and other hidden utilities.
- C. This unit should not be installed over a tub or shower.**
- D. Never place a switch where it can be reached from a tub or shower.

LIMITED WARRANTY

The Fan Motor is warranted against defects in workmanship and materials for one year from date of purchase. This warranty does not apply for damage from accident, misuse or alteration. No other written or oral warranty applies. Only the manufacturer's warranty applies to this product.

Defective product may be returned to the Company for replacement or repair. The customer shall be responsible for all costs incurred in the removal and shipping of the product to be repaired. Within the limitations of this warranty, inoperative units should be returned to **TEKQUEST INDUSTRIES™, RUSH HAMPTON™ 2812 Commerce Square East, Birmingham AL 35210.** Merchandise returned to the factory must be accompanied by a return authorization number which is obtained from the Company location listed above or by telephone at **1-800-327-7175 or @ rushhampton.com**



 **RUSH HAMPTON**

