

"Experience the *Tuscan Chef* Advantage"



GX-B1 Medium Family Oven

GX-B1 Medium Family Oven

Tuscan Chef Outdoor Wood Fired Ovens

An affordable alternative to the traditional brick/clay style wood fired oven. These ovens are recognized for their efficient design, durable construction, versatility and ease of use.

The unique vertical design with separate chambers for the fire and oven allowing wood flavour smoke to enter the oven chamber for that traditional wood fired flavour. These ovens assemble faster (30 minutes), cures more easily than ceramic or clay ovens (1 hour) with 2 to 4 times more cooking space of similarly priced free standing wood fired ovens.

Tuscan Chef ovens are rated for temperatures up to 510°C (950°F) but most cooking will be done in the oven at temperatures between 232°C and 370°C (450°F and 700°F). Our ovens provide a combination of baking and roasting, that achieves a unique, and delicious option to preparing food in your BBQ or kitchen oven.

Our ovens are suitable for preparing all kinds of food from pizzas, roasts, ribs, poultry, lamb, vegetables, brisket, bread, pies and the creativity of any discerning outdoor chef. Invite your friends over and discover the fun and entertainment pleasures of a Tuscan Chef Outdoor Oven.



Look for these *Tuscan Chef* Accessories to protect and enhance your cooking experience!



10035 35" pizza peel
12" x 14" aluminum blade



10413 13" pizza stone



10330 10" heavy duty
oven brush, with brass bristles
and scraper



10603 medium oven
cover for GX-B1

www.tuscanchefovens.com



Anatomy of a GX-B1 Tuscan Chef Oven

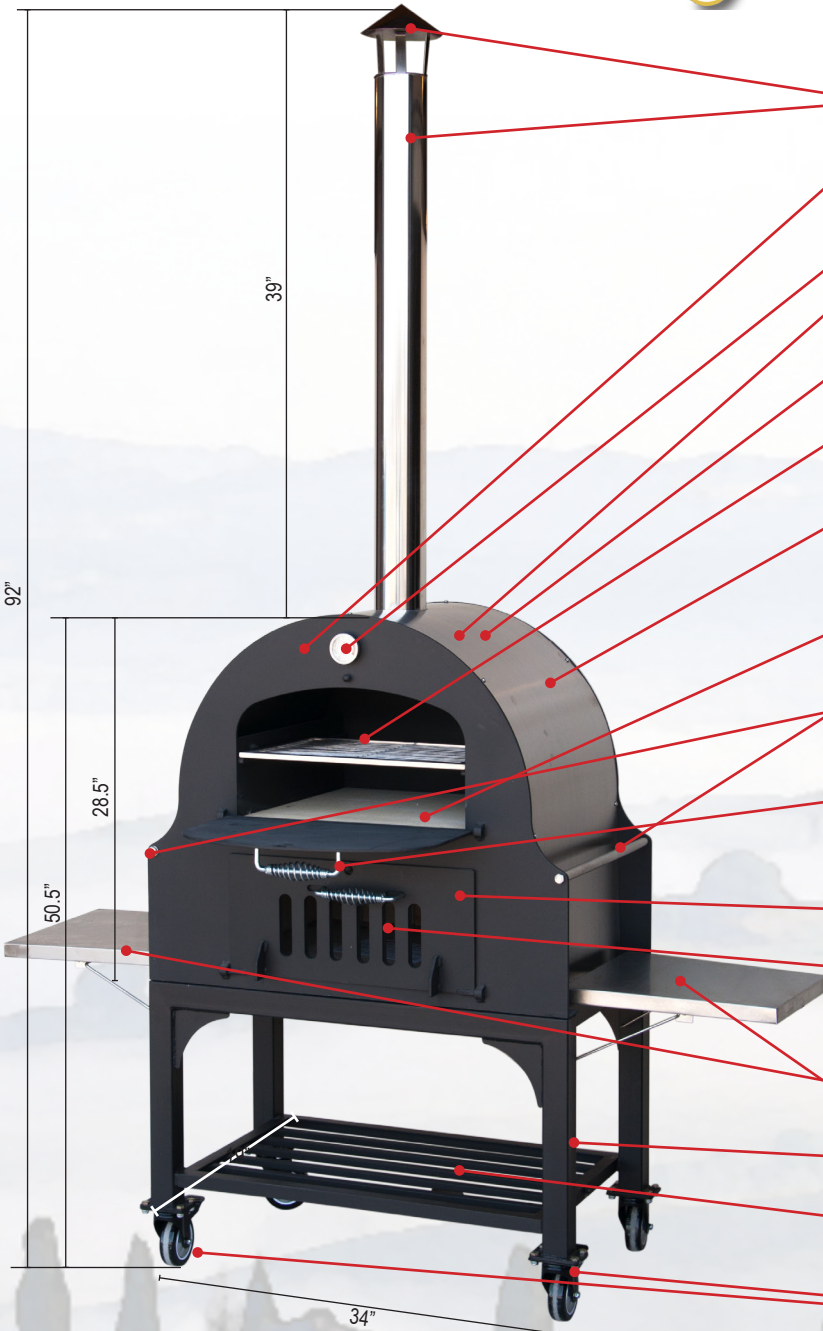

- Stainless steel chimney pipe with spark guard
- 6MM (1/4") welded steel construction
- Special Hi-Heat flat black paint on all steel surfaces
- Stainless steel temperature gauge
- 2" of insulation surrounds fire and oven chambers
- Sides and top are wrapped with 304 Stainless Steel
- Secondary removable stainless steel shelf
- Smoke from Firebox enters on each side of oven chamber
- 1 1/2" ceramic stone forms base of oven
- Stainless steel round side handles for manoeuvrability
- Spiral heat deflecting metal handles on fire chamber and oven door for ease of opening and closing
- Firebox is lined with 1" thick refractory fire brick
- Fire chamber door with adjustable damper for effective heat control
- Stainless Steel Side Shelves
- Welded steel cart frame
- Heavy duty steel shelf for wood storage
- 4" heavy duty casters (2 locking)

GX-B1 Medium Oven with cart

Oven Size:	28.5"x 34"x 19"
Cook Chamber Interior:	10"x 18.25"x 18.5"
Fire Chamber Interior:	7"x 21"x 16"
Chimney and Cap:	39"H x 4" Dia
Cart/Stand:	23"x 34"x 19"
Weight: Oven:	430 lbs.
Cart:	55 lbs.
Overall Height: (including Chimney & cap)	92"

Authorized Dealer:

