

# Zaor<sup>®</sup>

**UPGRADE YOUR SPACE**

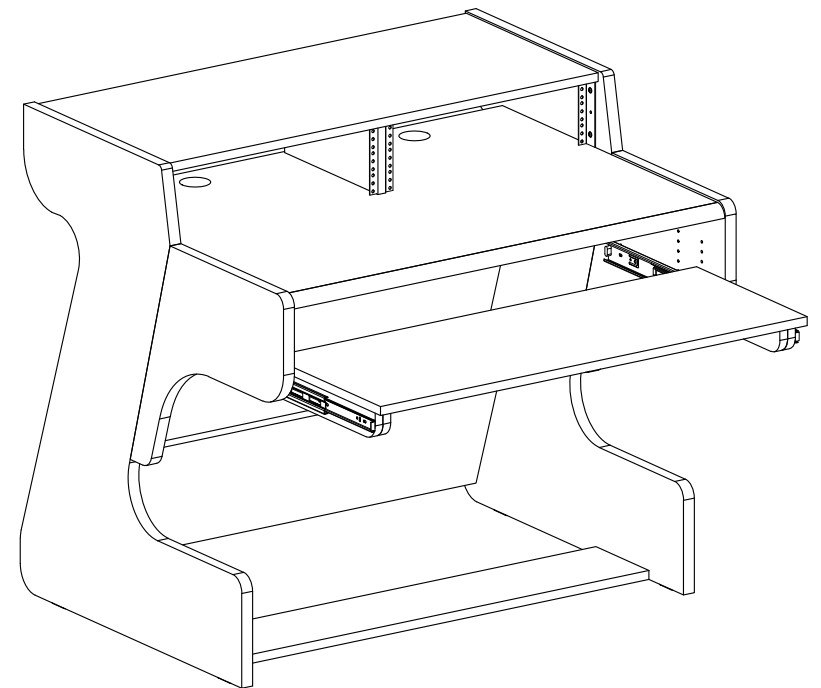

## **Miza 49 Flex**

### **Assembly Manual**

## Assembly Manual

Unpack the parts carefully and set up so that you can see the part numbers clearly. In the big box you should find a small cardboard box with all the screws and bolts for assembly.

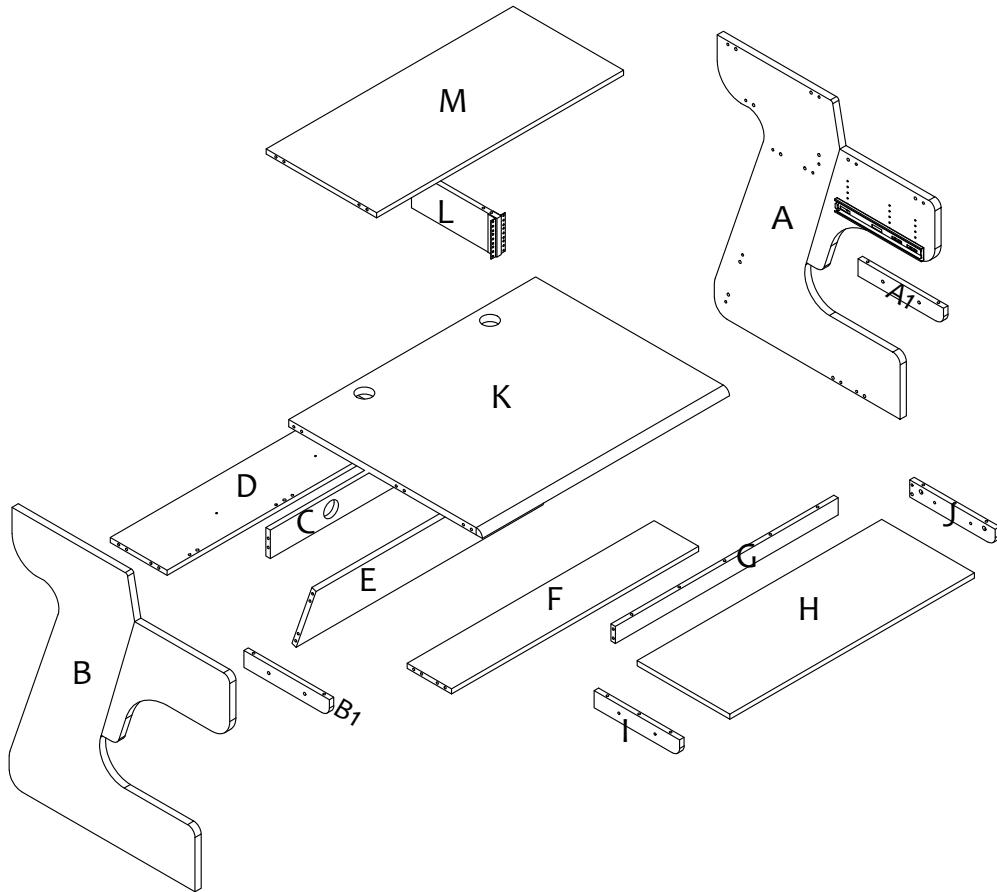

Here you have an exploded view of the whole desk and how it is supposed to come together. We use high quality furniture assembly components from renowned EU manufacturers. Please, never use force. These parts should come together easily, in case of doubt check the manual again or contact support.

## Assembly Manual

Thanks for choosing a piece of furniture from Zaor. Before you can enjoy the use of it you need to build it. We tried to put all the explanations necessary for a safe build, when in doubt please get in touch or check out our Youtube channel where we are putting more and more assembly videos to help you with this important task. Enjoy!

### General technique for putting together Zaor desks

The assembly of your desk uses special kits. Here's how to use them

- 1) On the piece with the threaded insert(s), put in the system bolt(s) and tighten making sure to align the hole in the system bolt at a 90° angle.

Please note that the system bolt may have a little slack in this position, which is fine!

- 2) Ensure that the hole in the bolt aligns with the opening in the other piece to be able to put in the safety screw.

- 3) In each hole in the second piece, put in a cone shaped safety screw and tighten with a cross screw driver - without forcing. The 2 parts will now be safely attached.

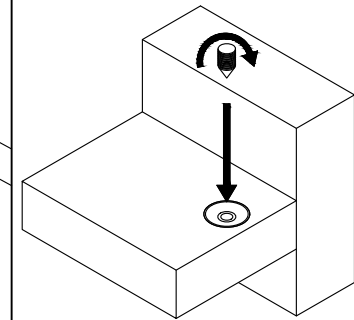
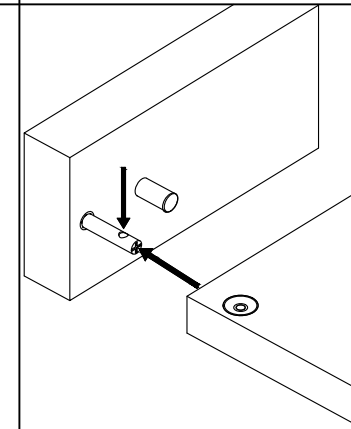
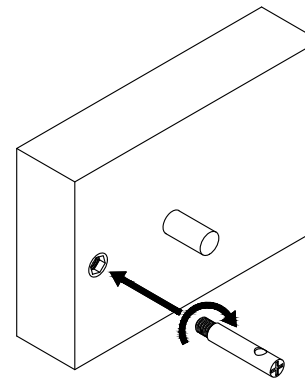

## Assembly Manual

### STEP 1

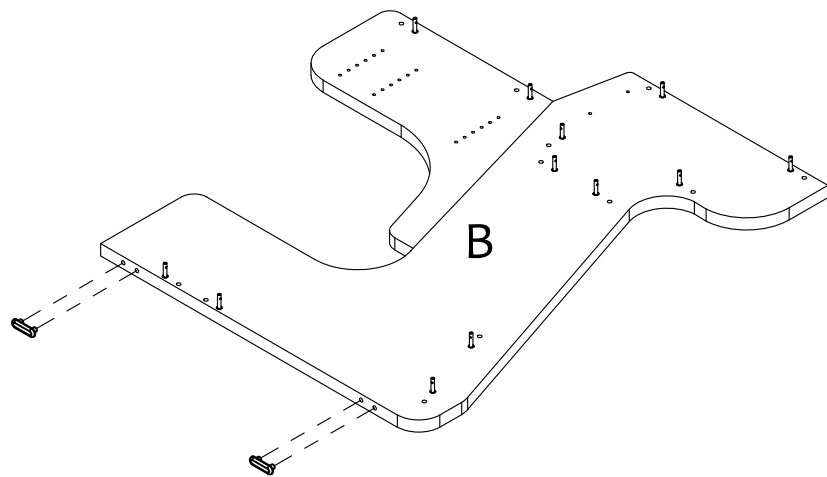
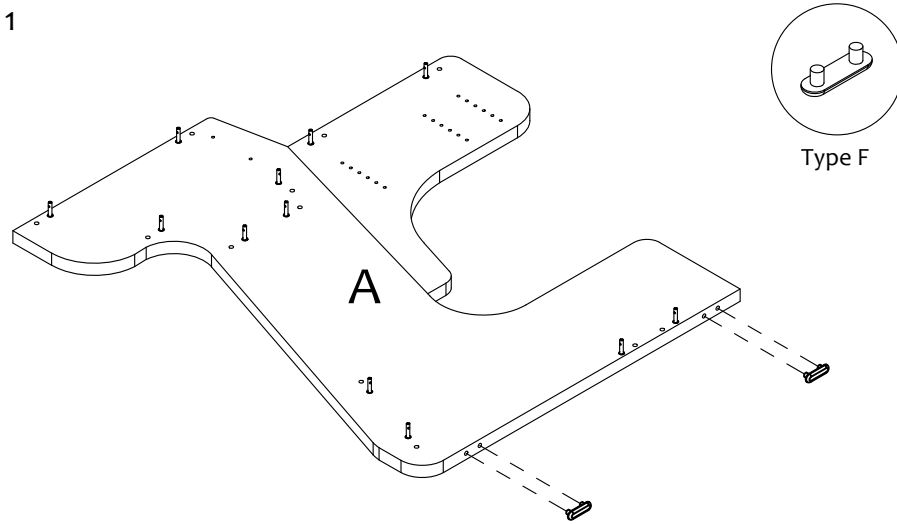

## Assembly Manual

### STEP 2

Left

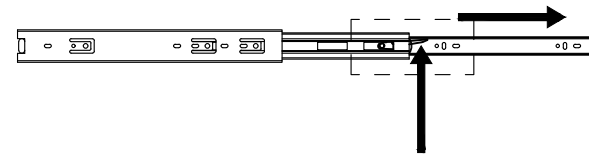
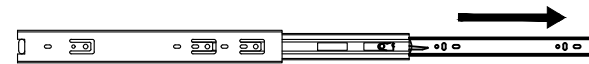

Slider 1 (L)

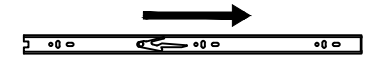

Slider 2 (L)

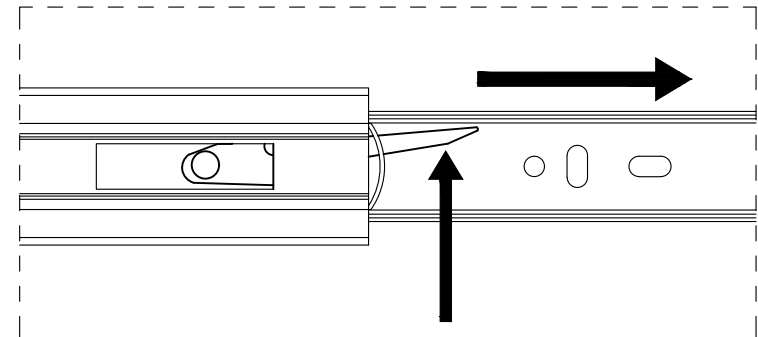

## Assembly Manual

### STEP 3

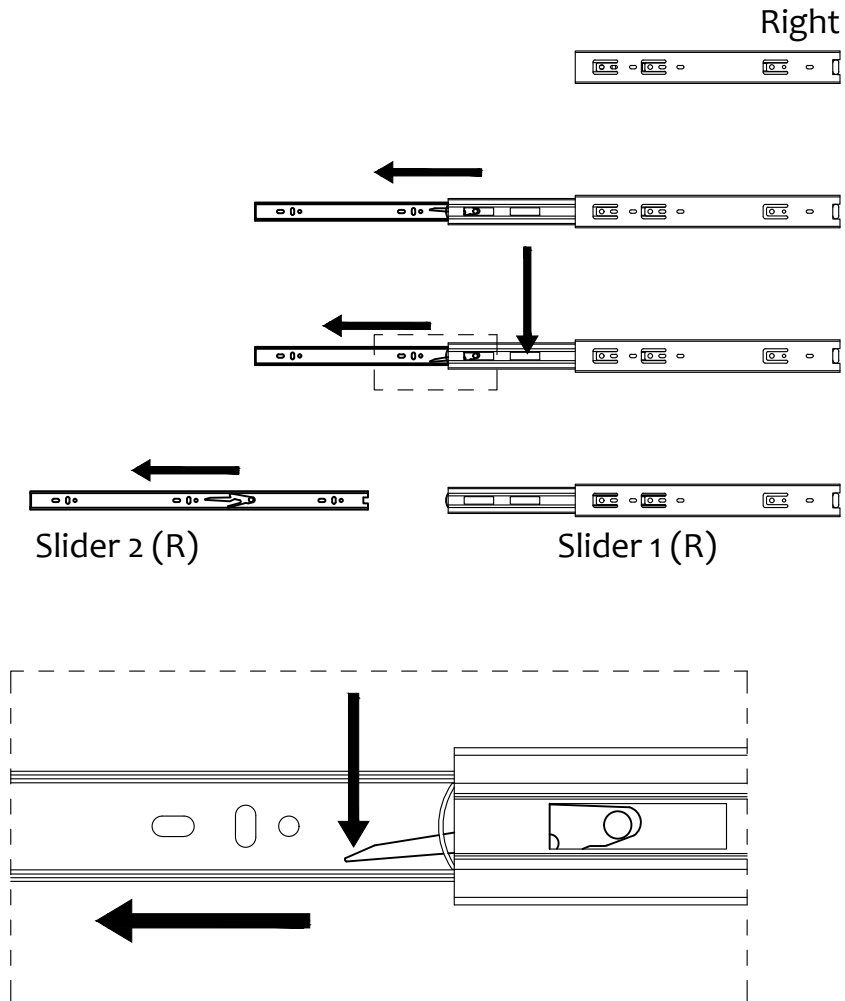

## Assembly Manual

### STEP 4

### Choose Height

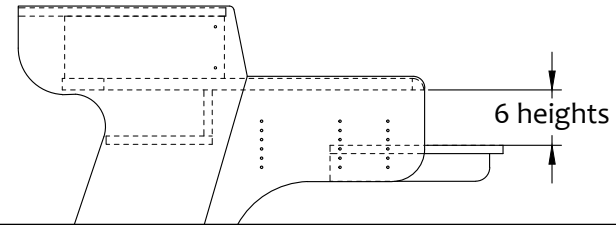

- 1st 20 mm
- 2nd 40 mm
- 3rd 60 mm
- 4th 80mm
- 5th 100 mm
- 6th 120 mm

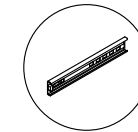
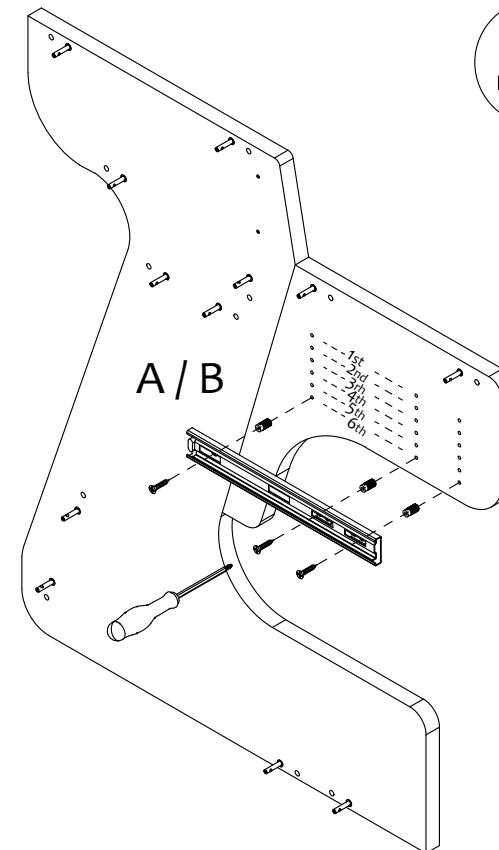

Slider 1

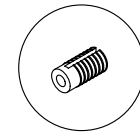

TYPE I

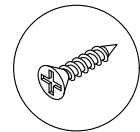

Type S2

## Assembly Manual

### STEP 5

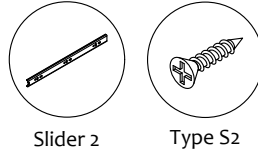
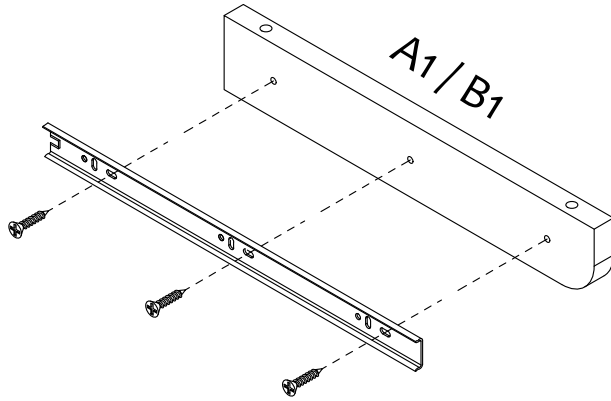

Slider 2

Type S2

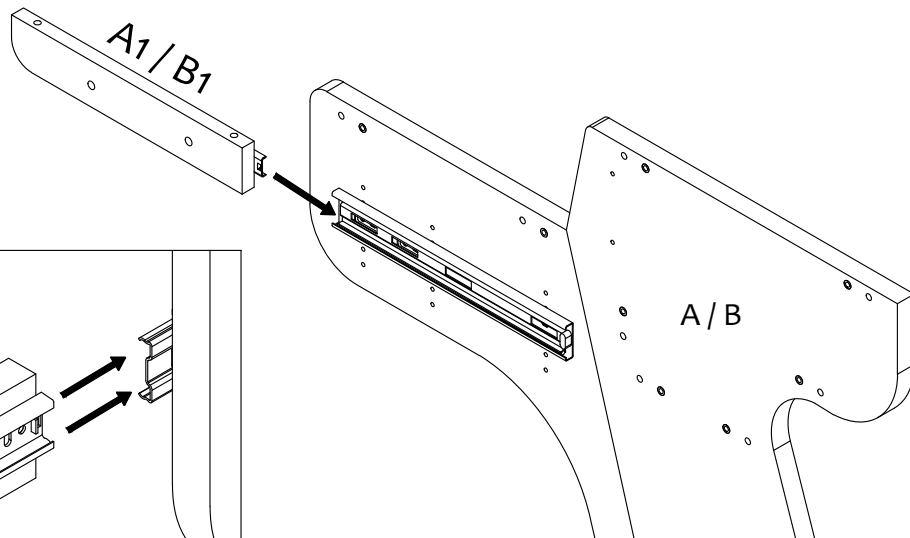

## Assembly Manual

### STEP 6

Push wooden dowels type W in the appropriate holes

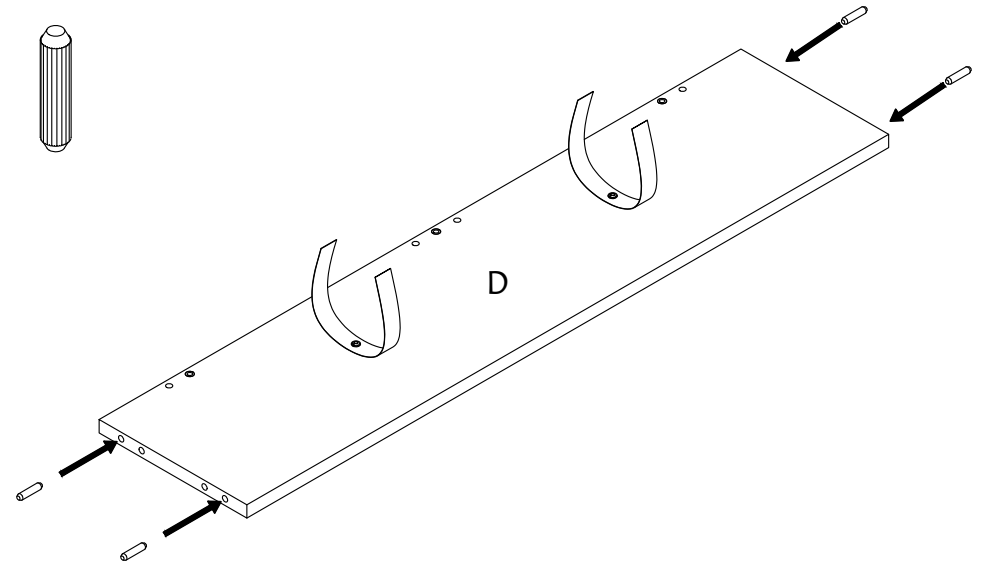
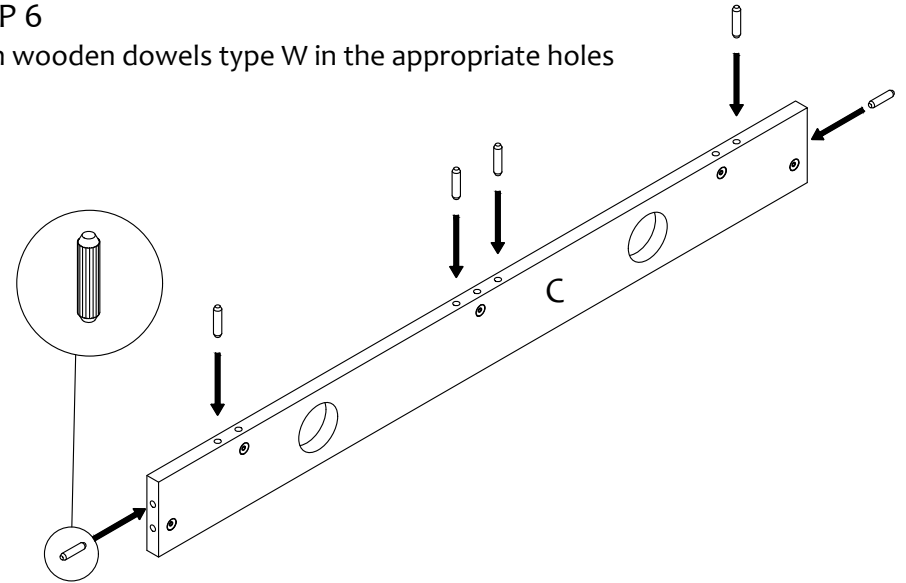

## Assembly Manual

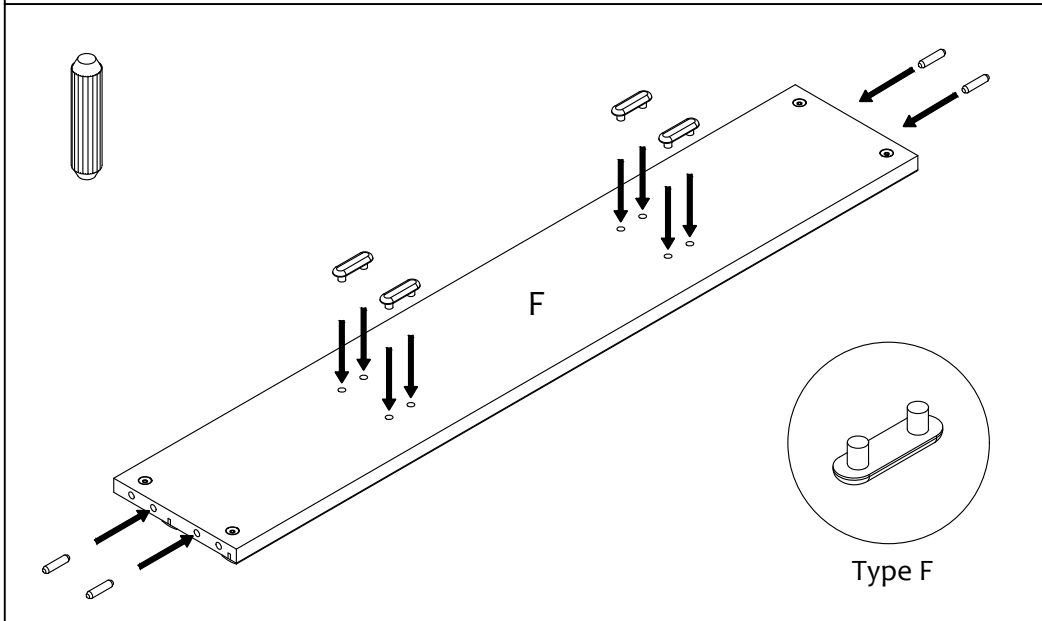
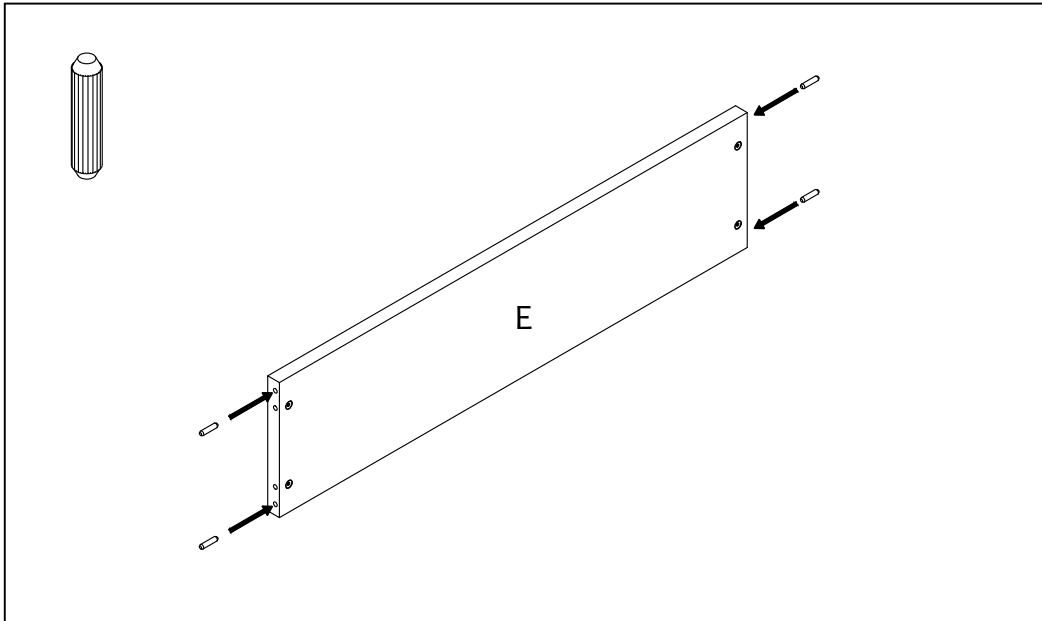

## Assembly Manual

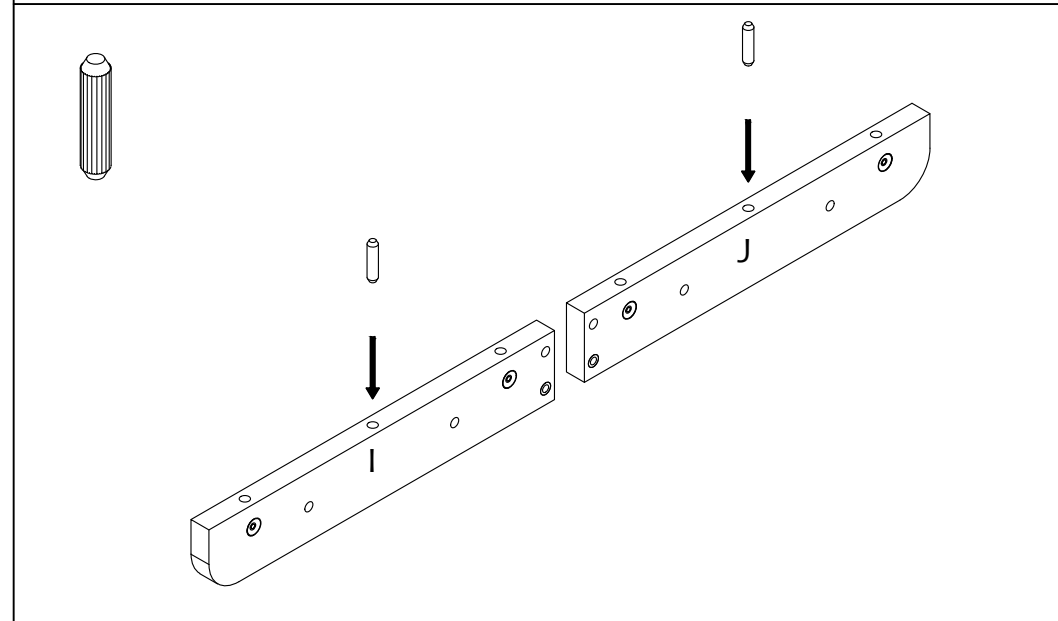
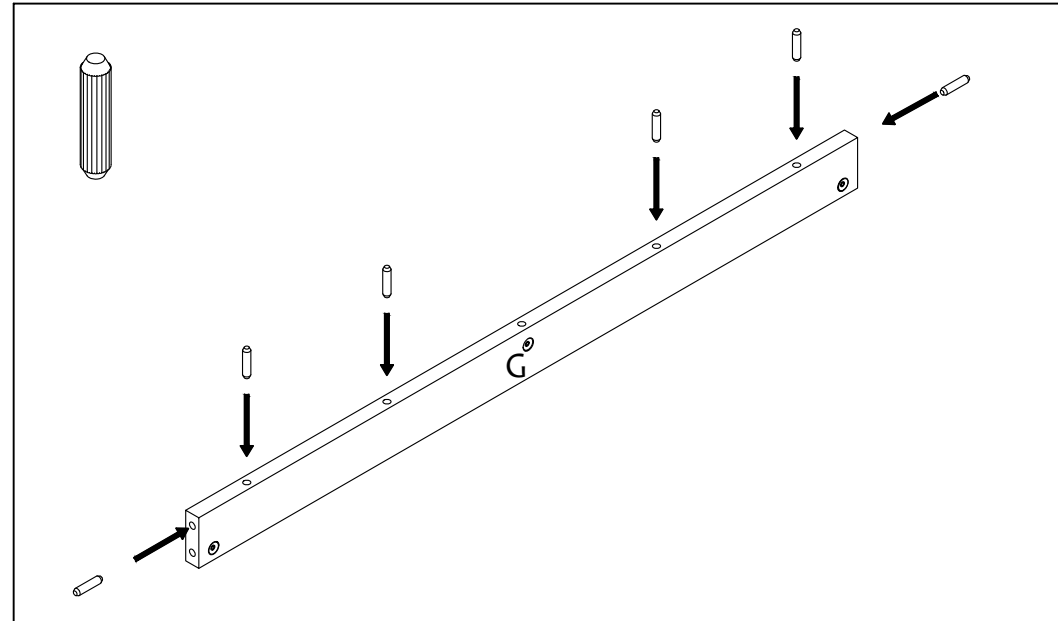

## Assembly Manual

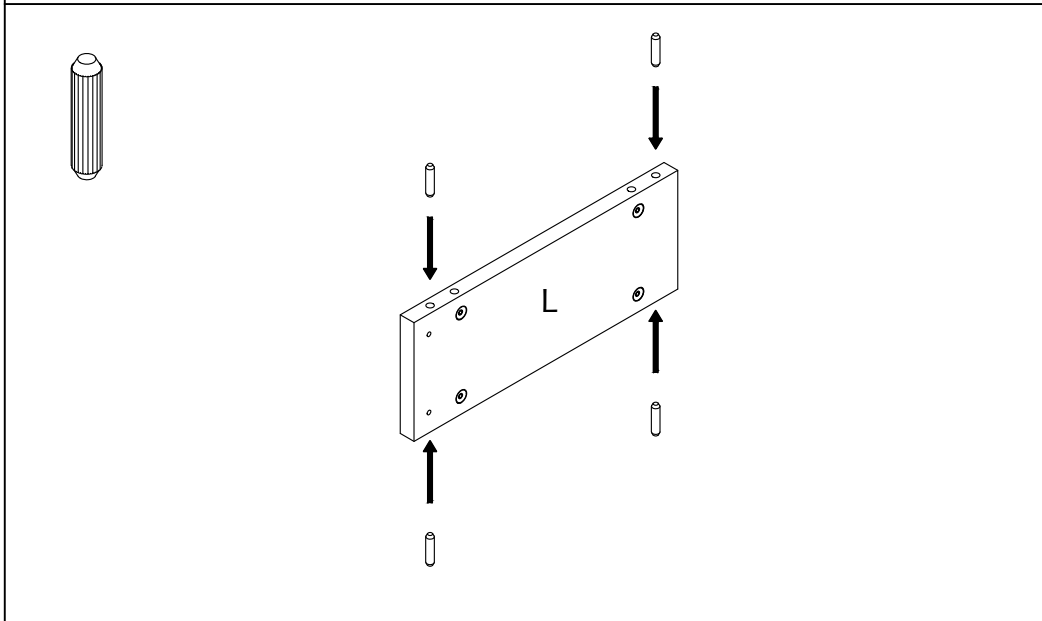
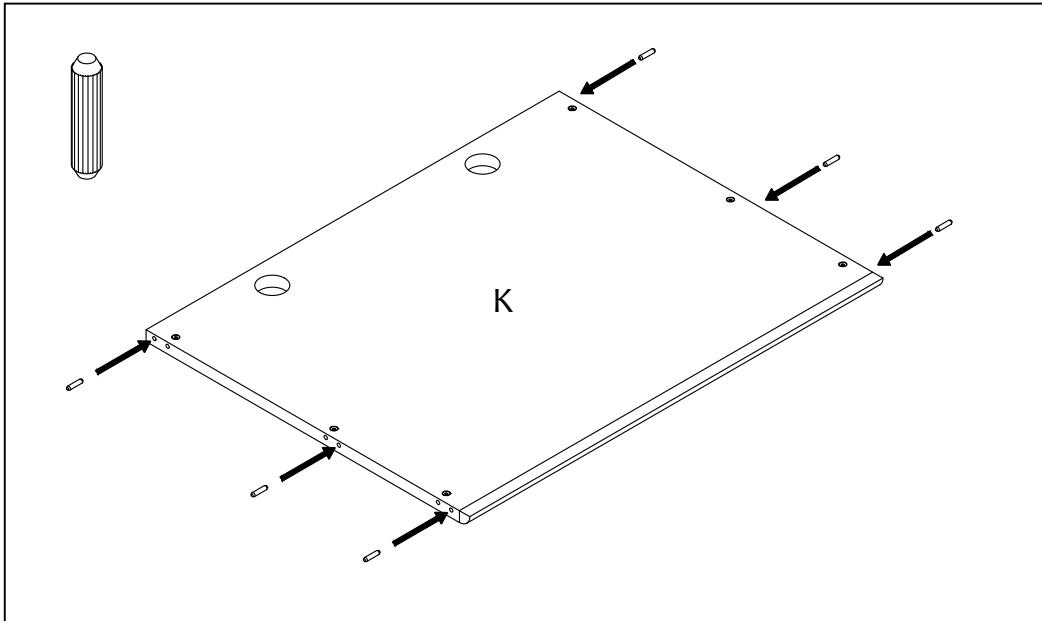

## Assembly Manual

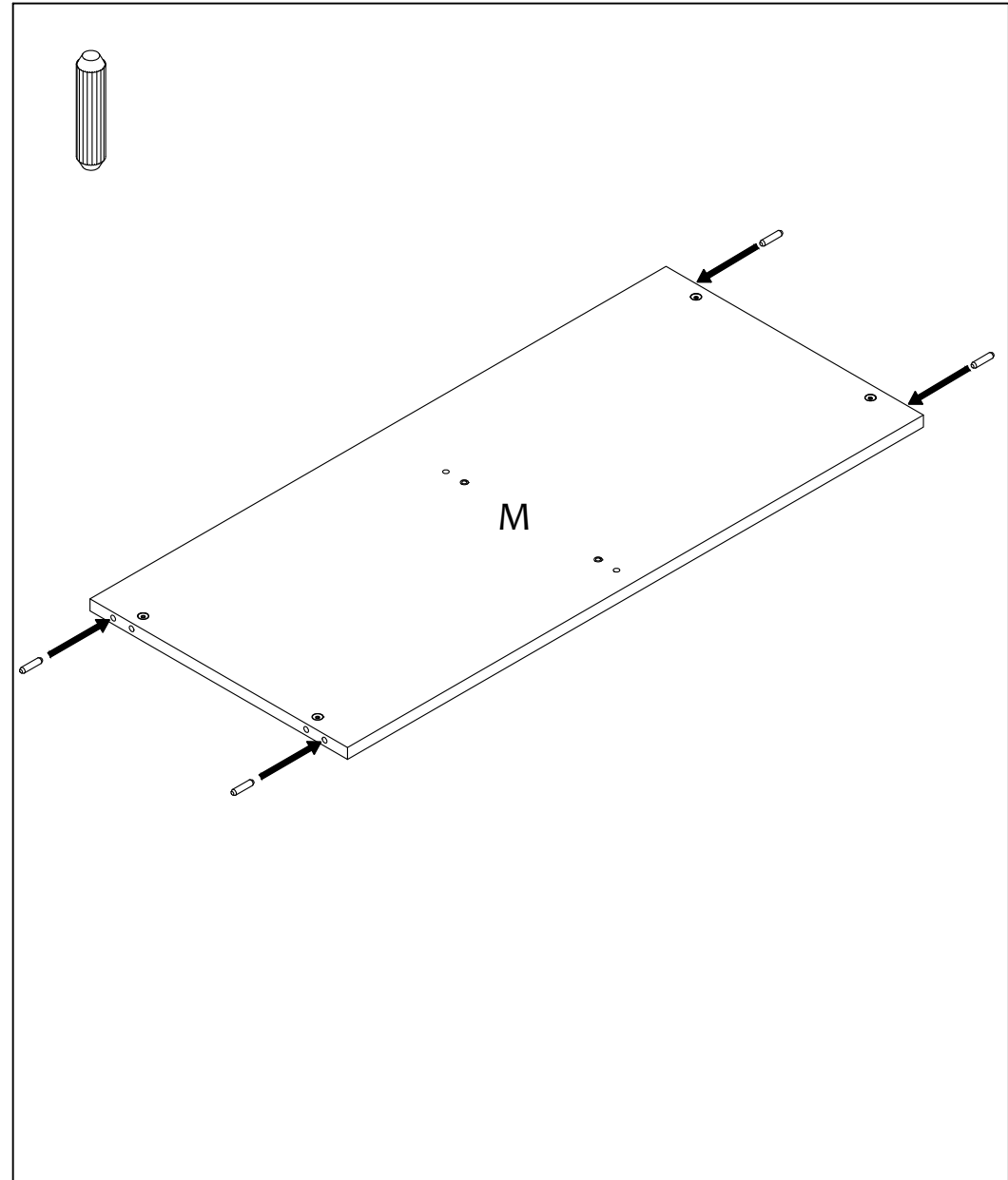

## Assembly Manual

### STEP 7

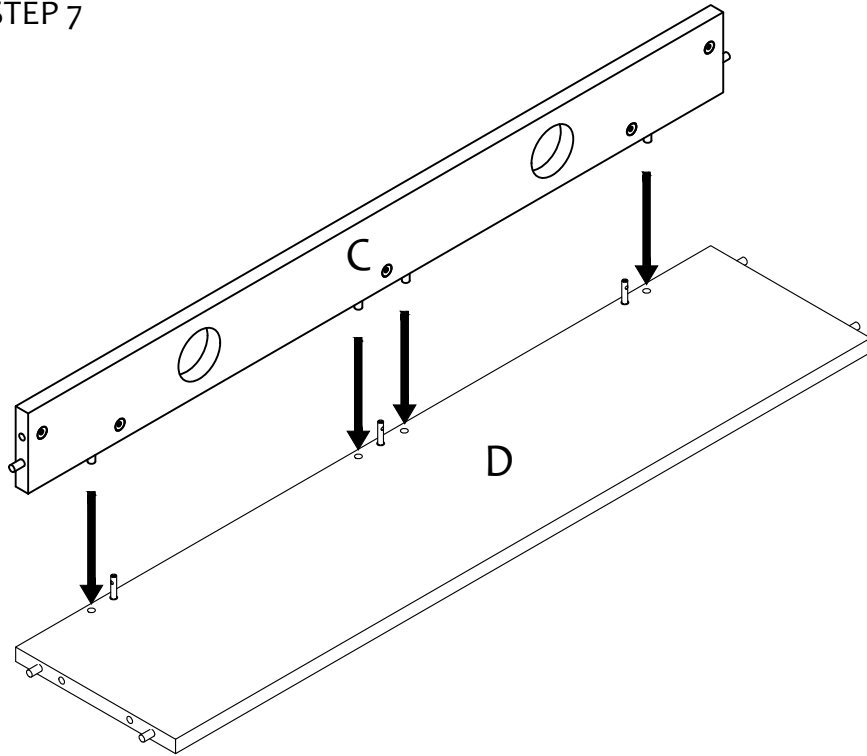

Join panels C and D. Attach, using the system bolts that you mount on the threaded inserts in panel n°C. Adjust so they are pointing such that holes can be seen when inserted into panel n°D (no need to tighten them). Use the small slanted screws to tighten the connection between the two panels. Proceed likewise for the other connections.

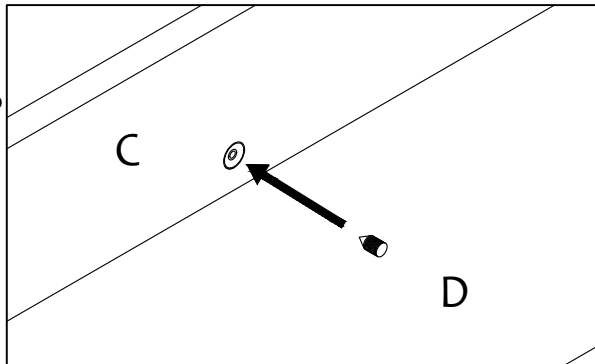

## Assembly Manual

### STEP 8

Use screws Type Rb

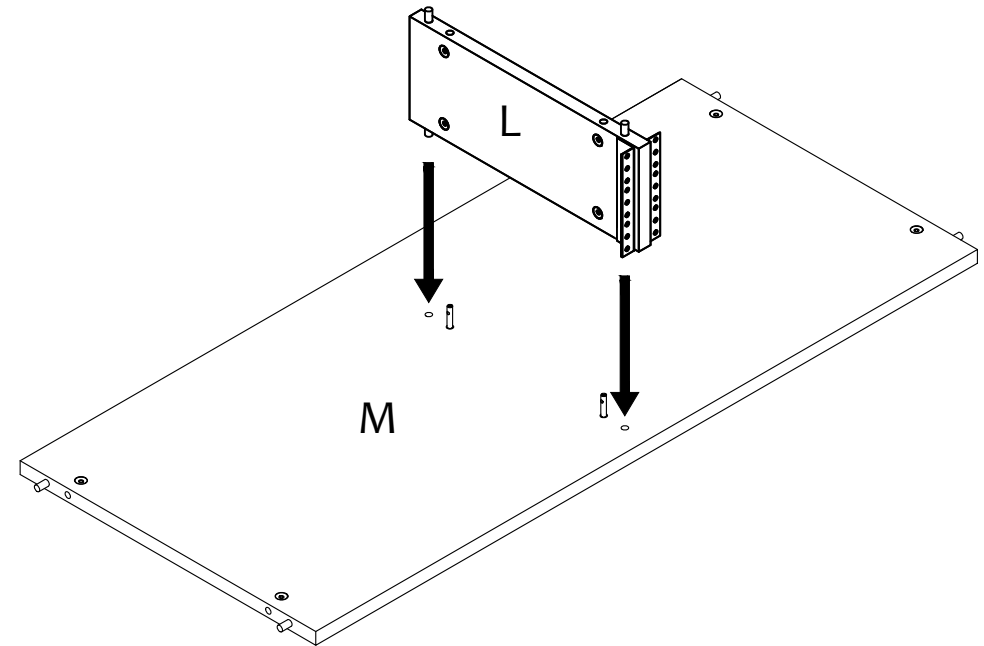
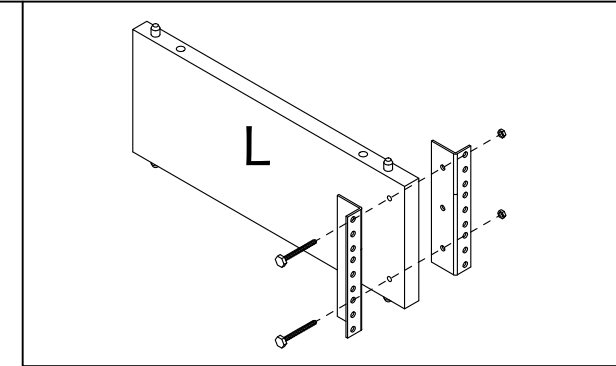



## Assembly Manual

### STEP 9

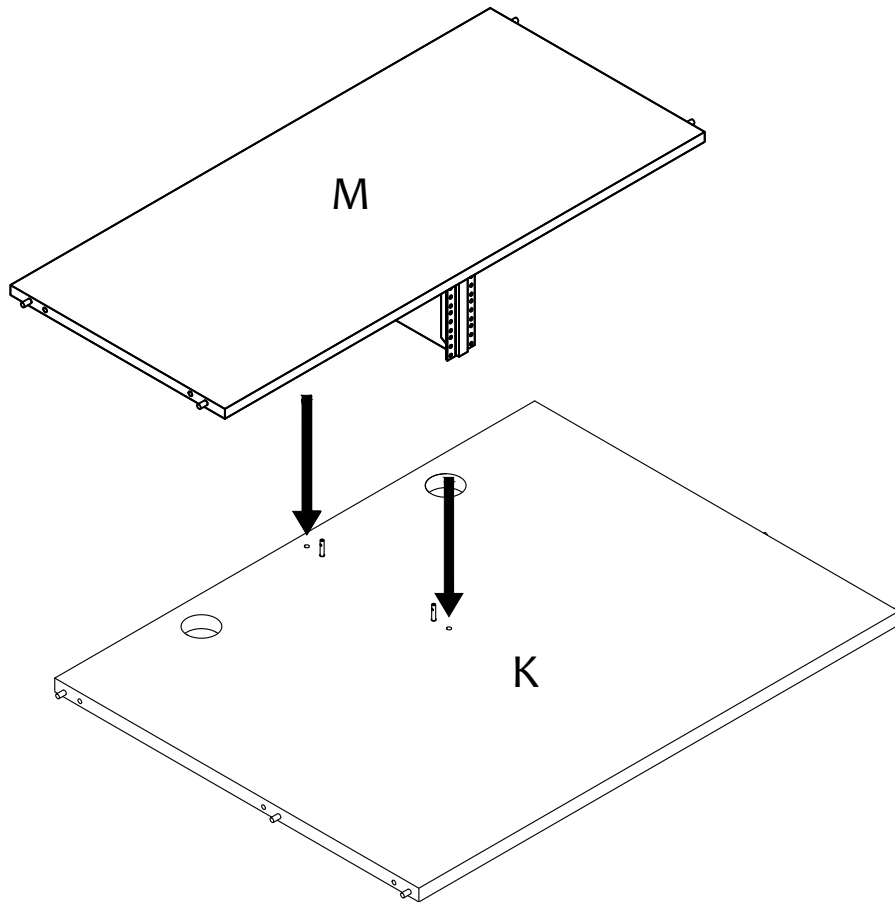

## Assembly Manual

### STEP 10

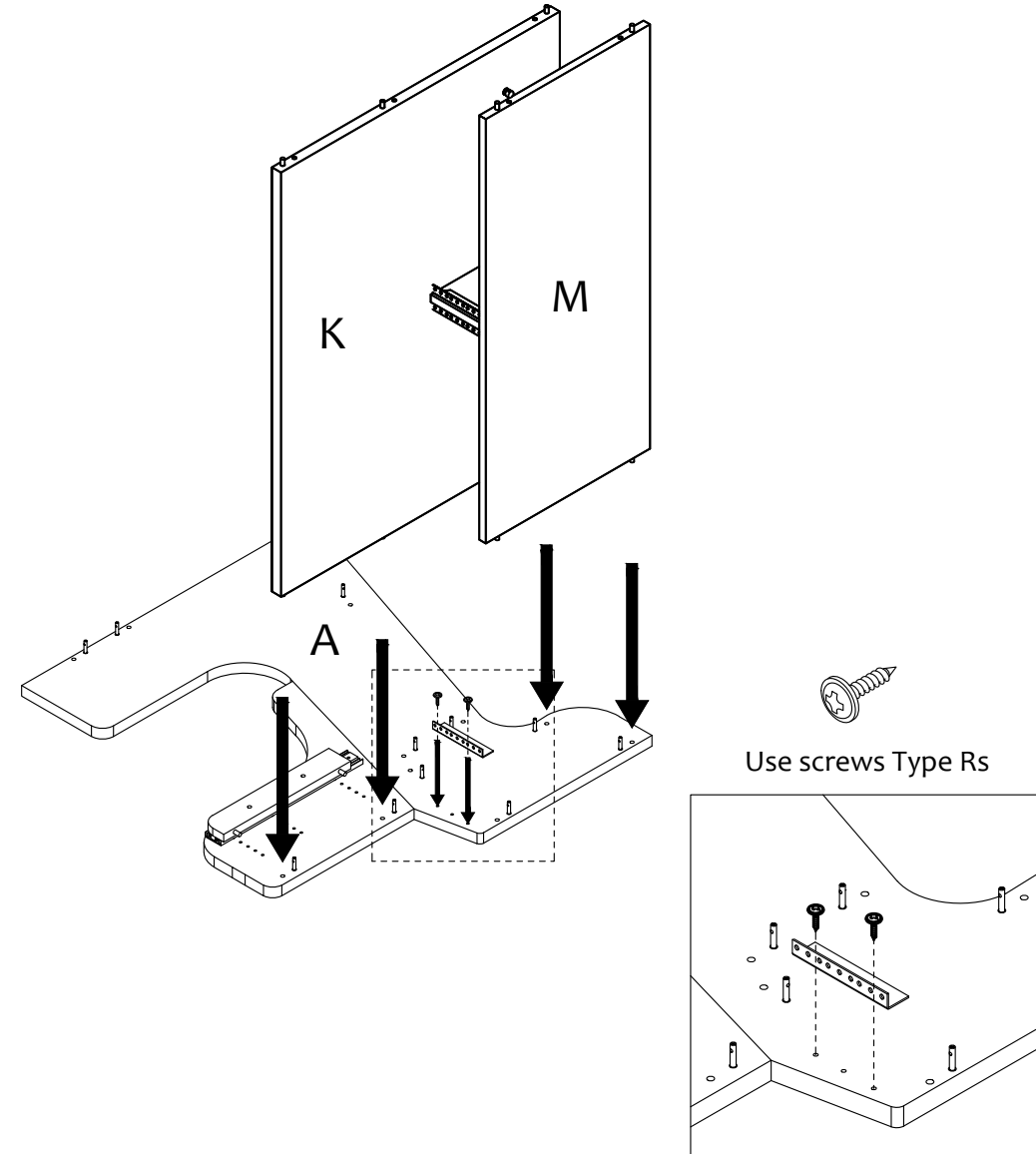

## Assembly Manual

### STEP 11

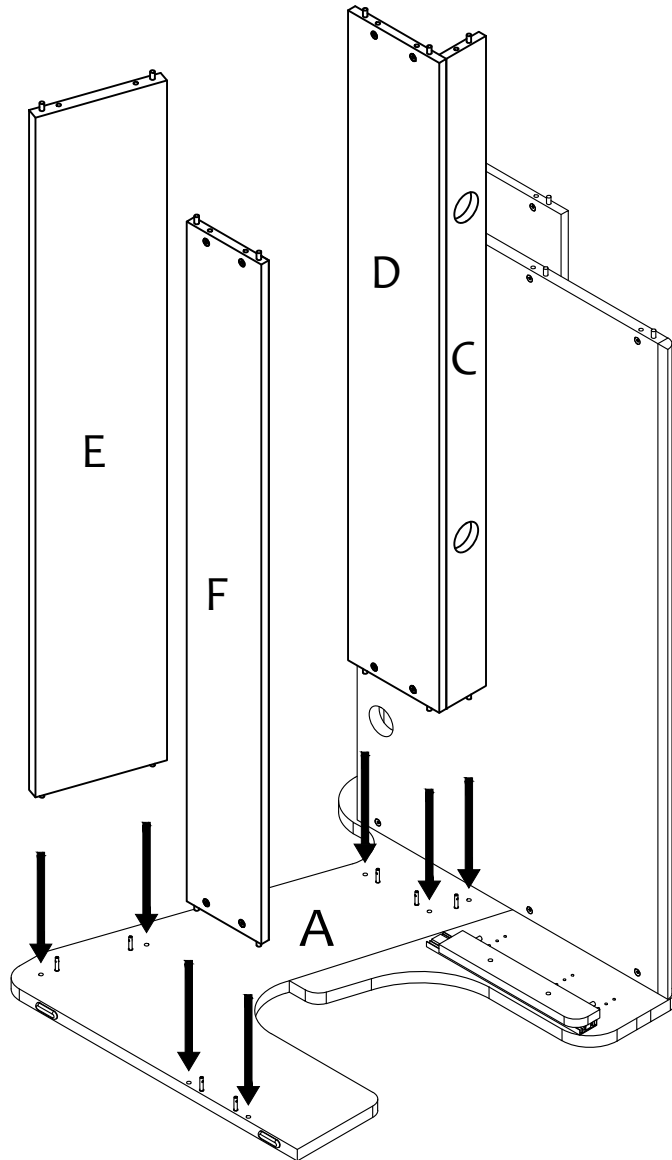

## Assembly Manual

### STEP 12

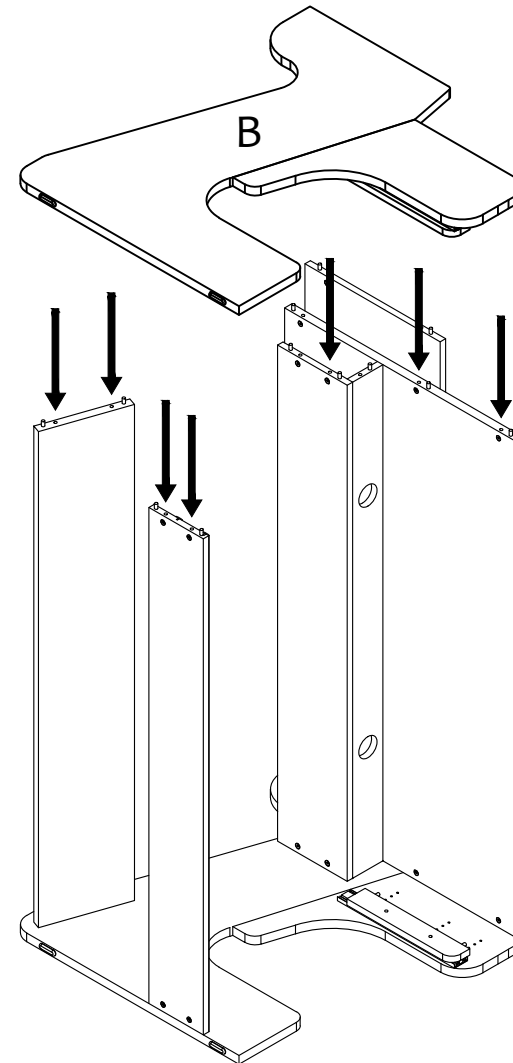

Use screws Type Rs

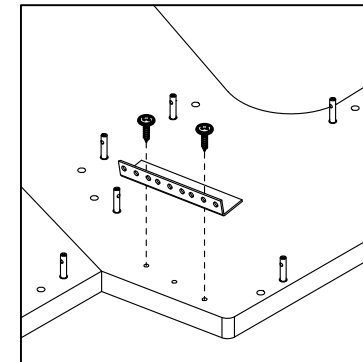

## Assembly Manual

### STEP 13

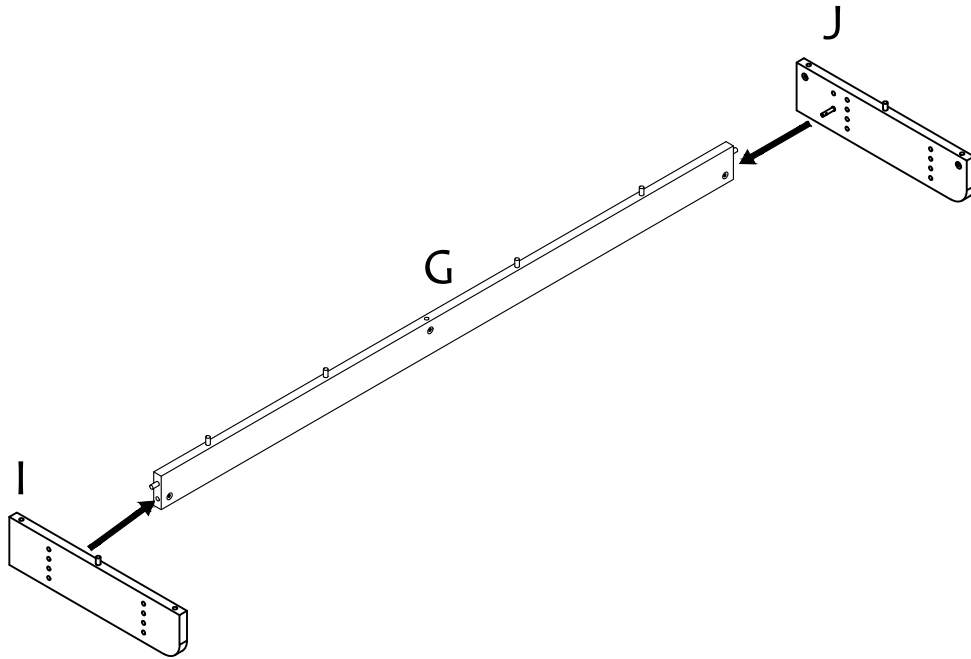

## Assembly Manual

### STEP 14

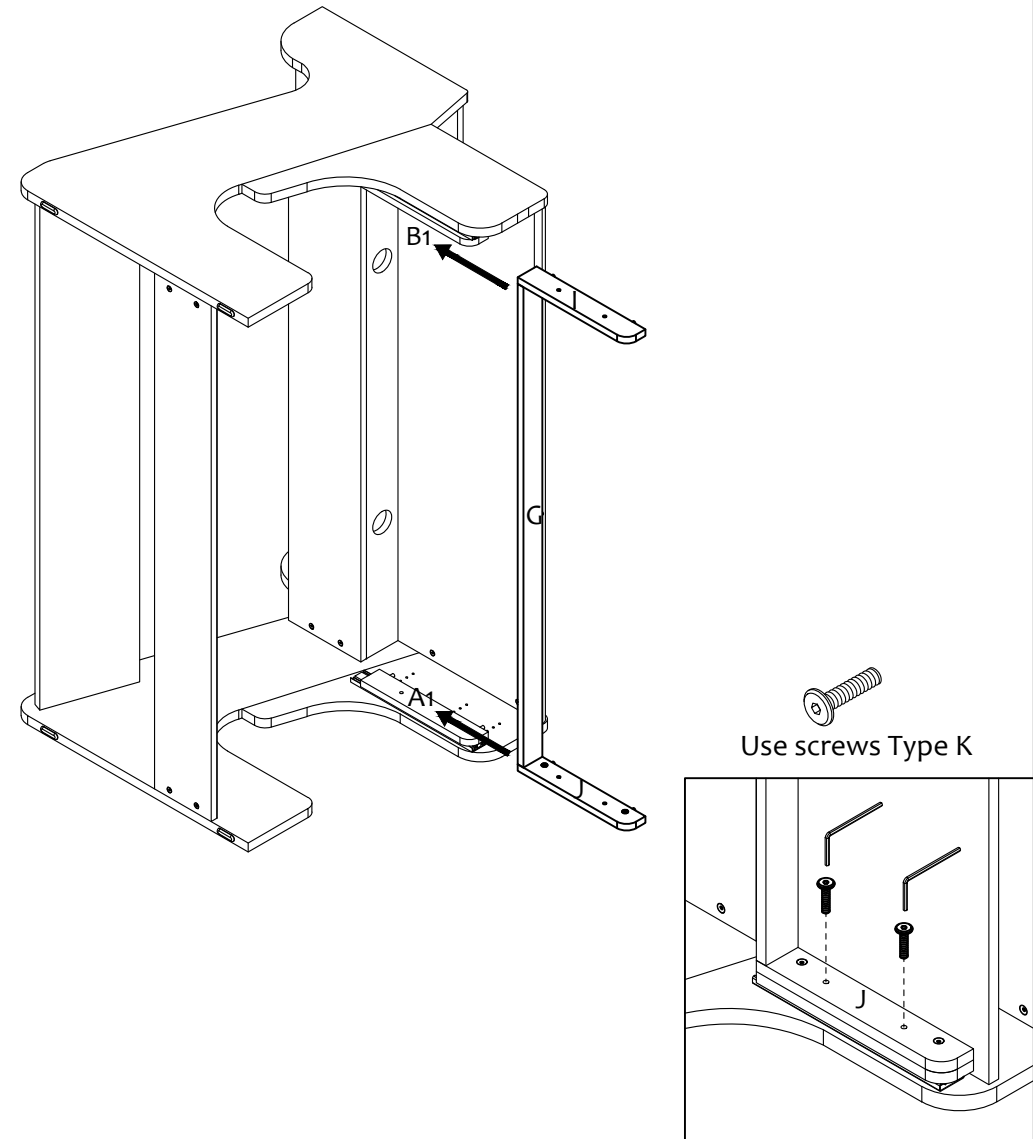

## Assembly Manual

### STEP 15

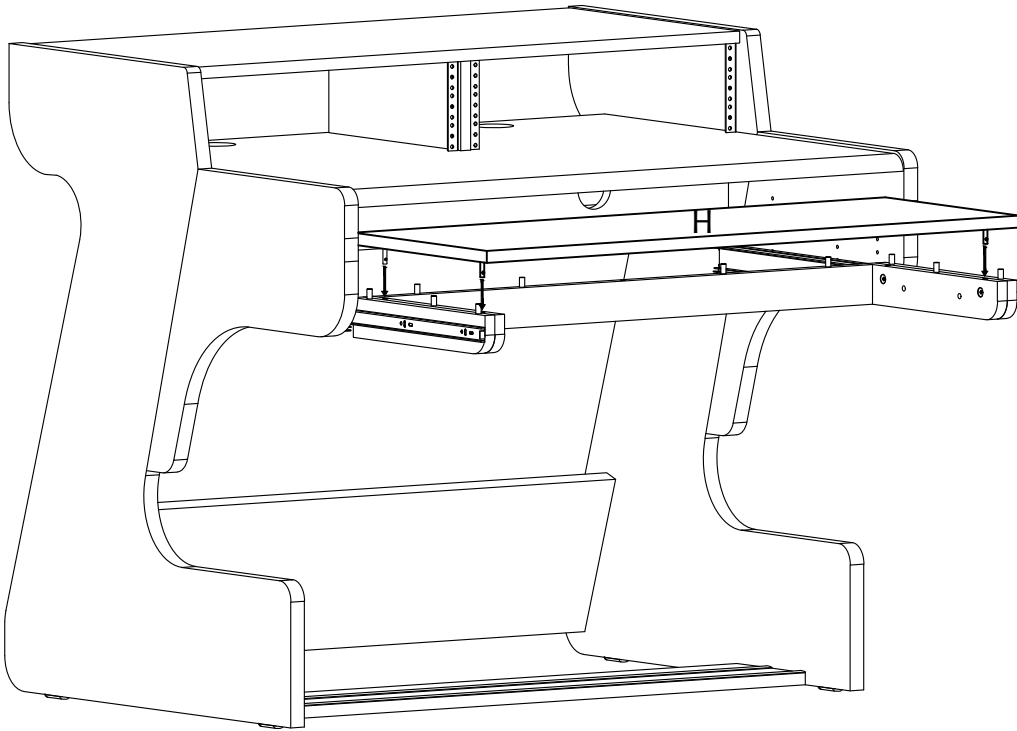

## Assembly Manual

### PACKING LIST:

<p>x38</p> <p>Assembly Kits</p>	<p>x44 Type W</p> <p>Wooden dowels</p>	<p>x04 Type K</p> <p>m6x30 mm</p>	<p>x8 Type F</p> <p>Plastic foot</p>
<p>x36 Type I</p> <p>Plastic insert</p>	<p>x02 Type SL</p> <p>Sliders</p>	<p>x12 Type S2</p> <p>3.5x16 mm</p>	<p>x1 Type H</p> <p>Hex wrench</p>
<p>x4 Type R</p> <p>Rack rail</p>	<p>x04 Type Rs</p> <p>Rack rail screws</p>	<p>x2 Type Rb</p> <p>Rack bolt screws</p>	<p>x24 Type Ru</p> <p>Rack units screws</p>

### TOOLS:

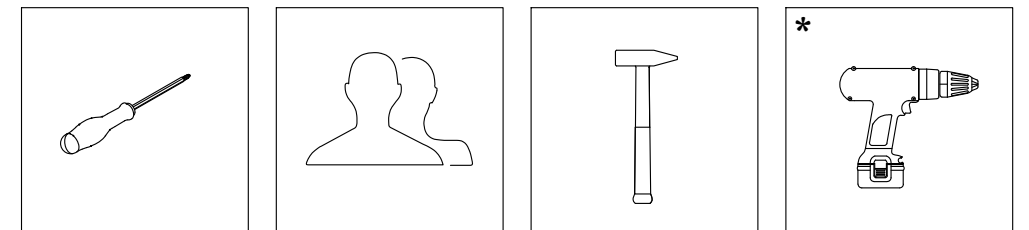

\*Suggested