

4

3

2

1

B

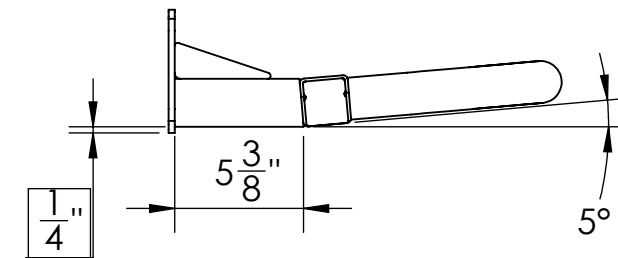
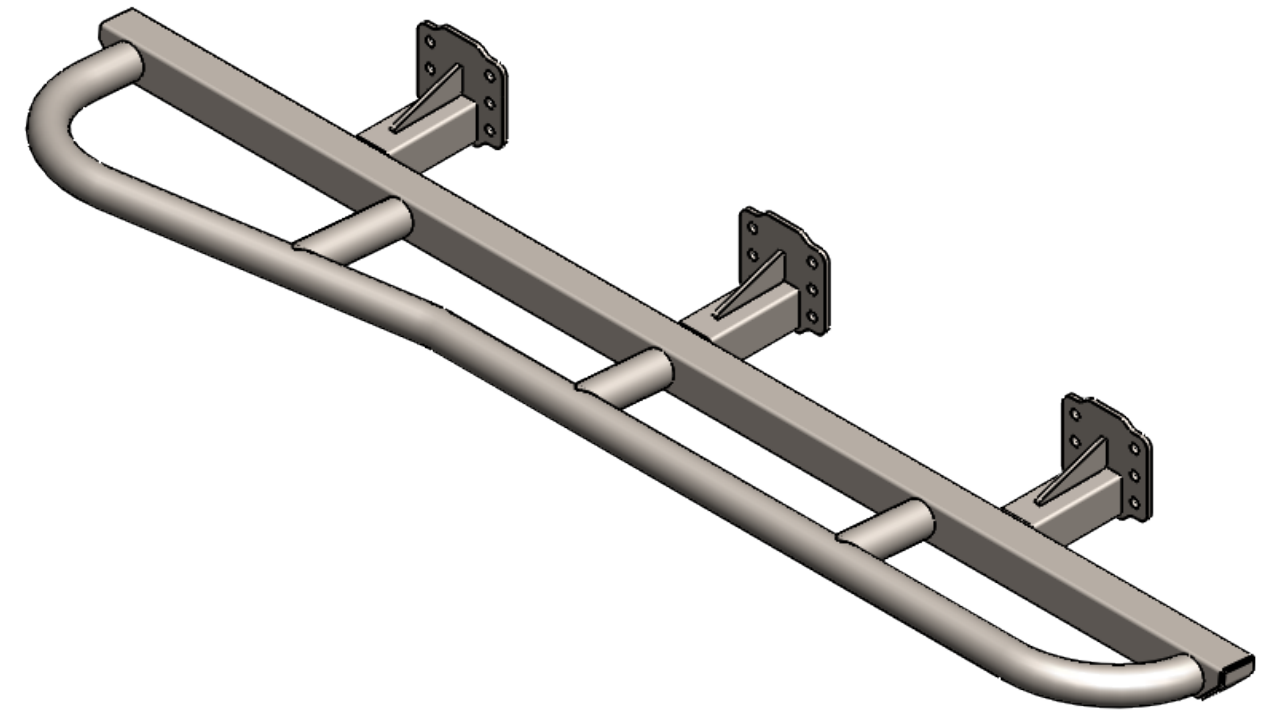
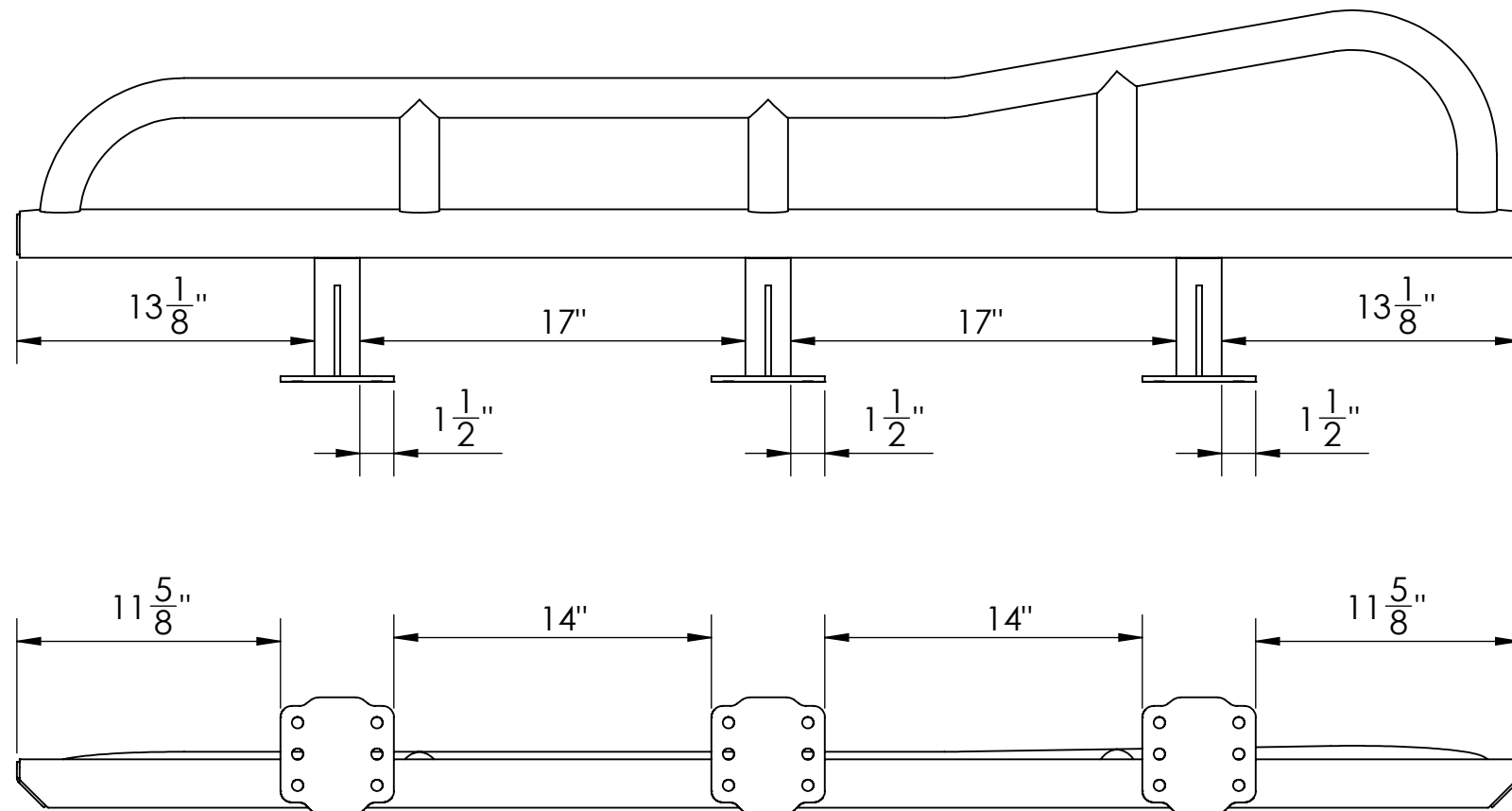

- 1) These are recommended dimensions for working with a 96-02 Toyota 4runner.
- 2) Recommended angle for sliders is 5°. If you exceed this the slider kickout could contact the bottom of the rear doors while opening.
- 3) If you have a body lift and are also using the slider adapter plates, you will have to add the height of your body lift to the boxed 1/4" dimension. If you are running over a 1.5" body lift you will have to flip the gusset triangle to the bottom side of the legs.
- 4) The legs have 2 inches of extra material on them over the recommended length of 5 3/8". This is in case you want to push them out farther. You can also go shorter than the recommended length if you want.

B

A

			TRUE NORTH FABRICATIONS LLC		
			TITLE:		
NAME	DATE				
DRAWN	AML	///			
MATERIAL	SEE NOTES		SIZE	DWG. NO.	REV
FINISH			<b>B</b>		
DO NOT SCALE DRAWING			SCALE: 1:8	WEIGHT:	

4

3

2

1

A