

NOT TO BE USED, DISCLOSED OR REPRODUCED WITHOUT PERMISSION.  
PROPERTY OF FREEDMAN SEATING COMPANY.

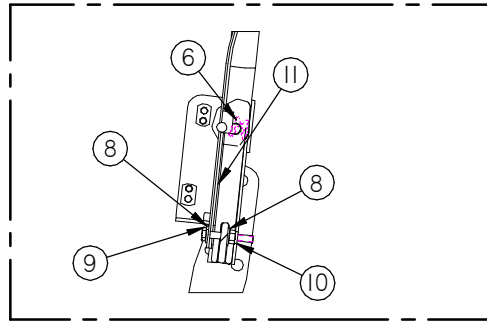

SECTION A-A

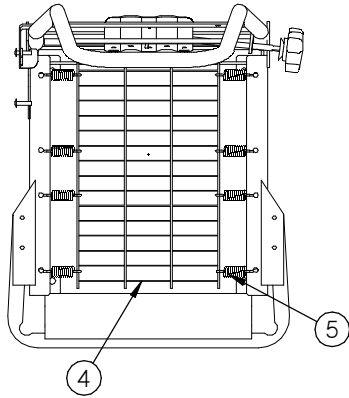
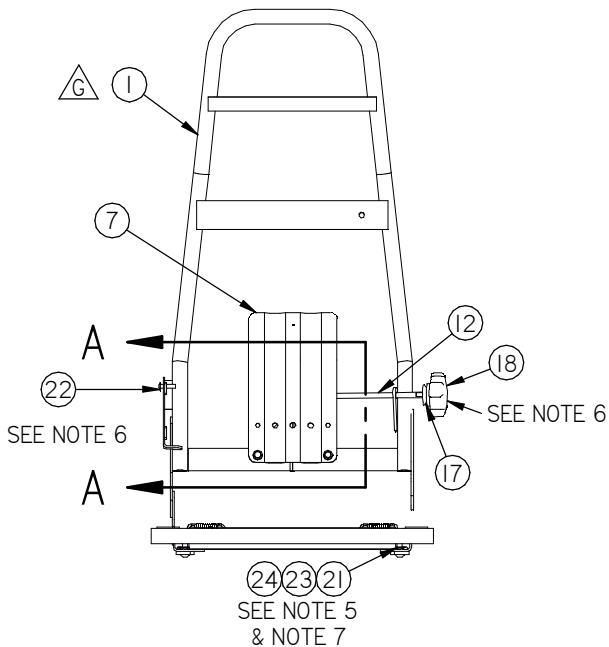

SEE NOTE 5  
& NOTE 7

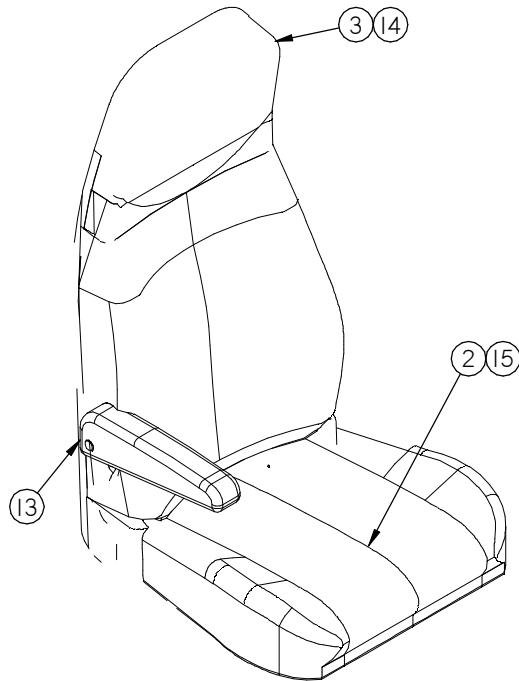



- NOTES:
- 1) VIEW WITHOUT FOAM AND COVER FOR CLARITY.
  - 2) AVERAGE SEAT WEIGHT IS 32LBS.
  - 3) SHIP LOOSE IN HARDWARE BAG 89143.
  - 4) FOR OEM INSTALLATION SEE VIEW B-B AND VIEW C-C.
  - 5) TORQUE 5/16-18 SCREWS TO 10-12 FT-LBS DURING INSTALLATION.
  - 6) INSTALL WITH BLUE LOC-TITE OR EQUIVALENT.
  - 7) OPTIONAL SPACER TO BE PLACED BETWEEN SEAT AND OEM SLIDES TO AID INSTALL.

Tolerances Unless Otherwise Specified:  
Fraction: 1/X +/- 1/4"  
Decimal: XXX +/- 0.02"  
          XXX +/- 0.01"  
Angular +/- 1 Degree

UNSPECIFIED RADIUS ARE 1/8"

| REV. | DATE     | ECN  | DESCRIPTION   | BY | CHKD. | APPD. |
|------|----------|------|---|----|-------|-------|
| A    | 07/26/10 | 1436 | RELEASED TO PRODUCTION  | NW | SC    | DK    |
| B    | 10/05/10 | 1481 | 30851 WAS 120214, 99702 WAS 180079,<br>99196 WAS 99195, ADD NOTES | NW | SC    | DK    |
| C    | 12/16/10 | 1632 | CHANGED NOTE 3  | EJ | MK    | DK    |
| D    | 02/15/11 | 1731 | 74836 WAS 56197, 74837 WAS 36146,<br>REMOVED 99084; ADDED NOTE    | EJ | MK    | DK    |
| E    | 08/03/17 | 6296 | REPLACE 55995 WITH 99161  | LH | NL    | MK    |
| F    | 09/06/19 | 7780 | 1000-225 WAS 71236, 1001-225 WAS 71237<br>UPDATED GLOBAL TOL      | JL | NL    | MK    |
| G    | 12/19    | 7938 | UPDATED PN 70276  | NL | JL    | MK    |

|            |    |   |          |  |
|------------|----|---|----------|--|
| SEE NOTE 3 | 24 | 4 | 30851    | SPACER   |
| SEE NOTE 3 | 23 | 4 | 99702    | 5/16-18UNC X 1-1/4" BTTN HEX HD, B0, NYLON PATCH |
|            | 22 | 2 | 99196    | SCREW, FLANG, 1/4-20 x 1                         |
| SEE NOTE 3 | 21 | 4 | 55594    | J-NUT, 5/16 - 18                                 |
|            | 20 | 1 | 99161    | SCREW, TORX, PAN HD, 10, 3/4" L, BL              |
|            | 19 | 1 | 55994    | SPACER   |
|            | 18 | 1 | 74836    | KNOB, 4 LOBE, 3" OD                              |
|            | 17 | 1 | 55996    | PLASTIC SPACER, BLACK (FOR SHORT STEM RECLINER)  |
|            | 16 | 1 | 55993    | RECLINER HANDLE, LH                              |
|            | 15 | 1 | 1000-225 | COVER, CUSHION, SHIELD, REC                      |
|            | 14 | 1 | 1001-225 | COVER, BACK, SHIELD, REC                         |
|            | 13 | 1 | 71804    | ARMREST, SHIELD, RH                              |
|            | 12 | 1 | 74837    | WELDMENT, LUMBAR, SHAFT, THREADED                |
|            | 11 | 2 | 56163    | BUMPER, RUBR, W/O WSHR, 23/32" DIA, GO           |
|            | 10 | 2 | 9419454  | 1/4-20UNC, LOC NUT, NYLON INS, G5, ZP            |
|            | 9  | 2 | 180042   | 1/4-20UNC x 1 3/4" HHCS, G5, ZP                  |
|            | 8  | 4 | 120392   | 1/4 FLAT WASHER, SAE, ZP                         |
|            | 7  | 1 | 14173    | LUMBAR, SHIELD                                   |
|            | 6  | 1 | 56151    | RING, RETAINING                                  |
|            | 5  | 8 | 55859    | SPRING   |
|            | 4  | 1 | 30859    | FLEX-O-LATOR                                     |
|            | 3  | 1 | 51270950 | FOAM, MOLDED, BACK, SHIELD, REC                  |
|            | 2  | 1 | 51130861 | SEAT FOAM, MOLDED, 97 FORD                       |
|            | 1  | 1 | 70276    | WLDMNT, SEAT FRAME, DRIVER, SHIELD REC           |

| ITEM   | QTY | PART #   | DESCRIPTION |
|--|-----|--|-------------|
| DRAWING NAME:<br><b>ASSY, IP SHIELD DRV, REC</b>   |     |  |             |
| MATERIAL:  |     |  <b>Freedman Seating Co.</b><br>4545 W. Augusta Blvd<br>Chicago, IL 60651 |             |
| SPECIFICATION:   |     | PROJECTION:   |             |
| AUTHORIZED: <br>DATE: 12/2/2019 |     | REF: _____<br>SUPERSEDES: _____<br>CHECKED: _____<br>APPROVED: _____   |             |
| BY: <b>Scmc</b><br>SIZE: <b>C</b>  |     | DRAWING No.: <b>71234</b><br>REV: <b>G</b>   |             |
| SCALE: NOT TO SCALE  |     | SHEET: 1 of 2  |             |

NOT TO BE USED, DISCLOSED OR REPRODUCED WITHOUT PERMISSION.  
PROPERTY OF FREEDMAN SEATING COMPANY.

| REV. | DATE     | ECN  | DESCRIPTION   | BY | CHKD. | APPD. |
|------|----------|------|---|----|-------|-------|
| A    | 07/26/10 | 1436 | RELEASED TO PRODUCTION  | NW | SC    | DK    |
| B    | 10/05/10 | 1481 | 30851 WAS 120214, 99702 WAS 180079,<br>99196 WAS 99195, ADD NOTES | NW | SC    | DK    |
| C    | 12/16/10 | 1632 | CHANGED NOTE 3  | EJ | MK    | DK    |
| D    | 02/15/11 | 1731 | 74836 WAS 56197, 74837 WAS 36146,<br>REMOVED 99084, ADDED NOTE    | EJ | MK    | DK    |
| E    | 08/03/17 | 6296 | REPLACE 55995 WITH 99161  | LH | NL    | MK    |
| F    | 09/06/19 | 7780 | 1000-225 WAS 71236, 1001-225 WAS 71237<br>UPDATED GLOBAL TOL      | JL | NL    | MK    |
| G    | 12/19    | 7938 | UPDATED PN 70276  | NL | JL    | MK    |

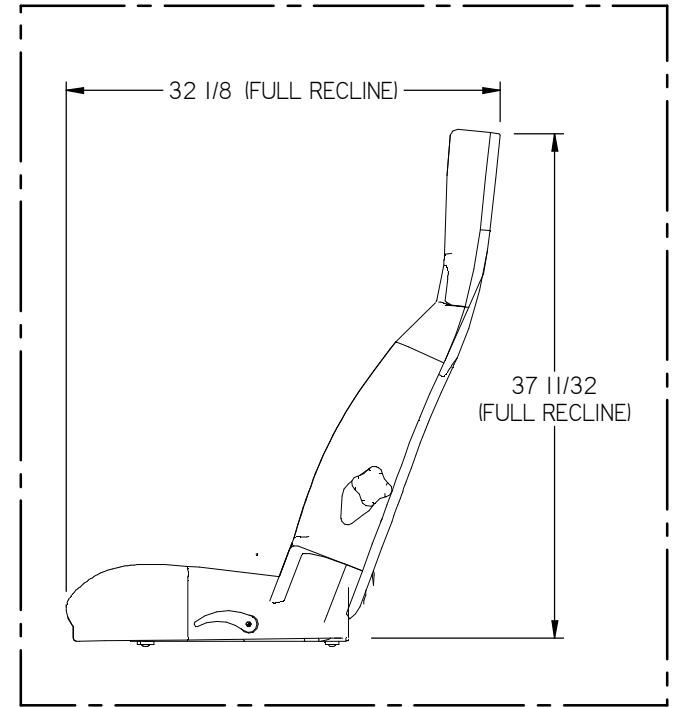
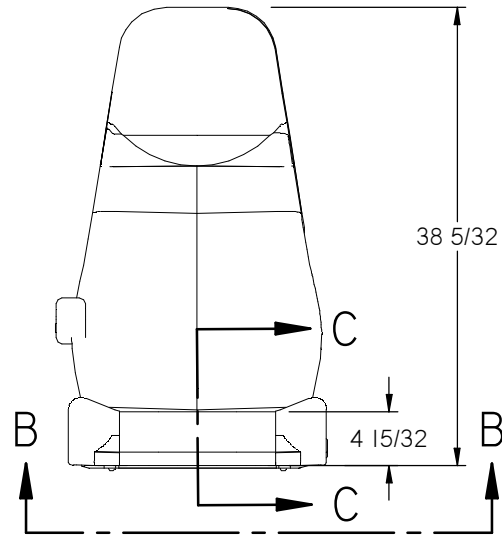
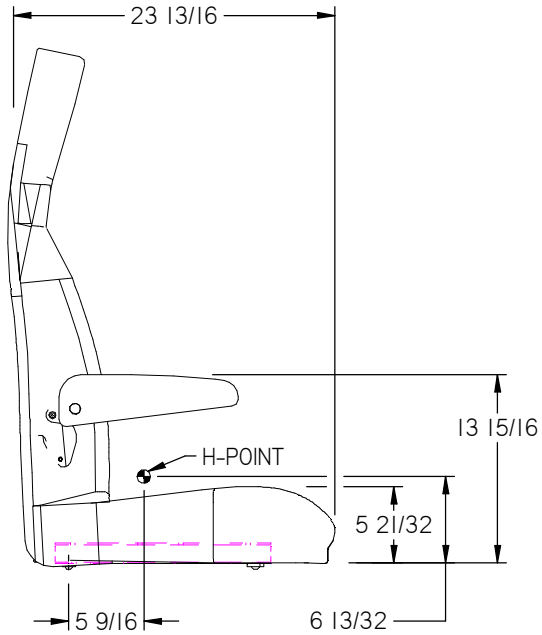
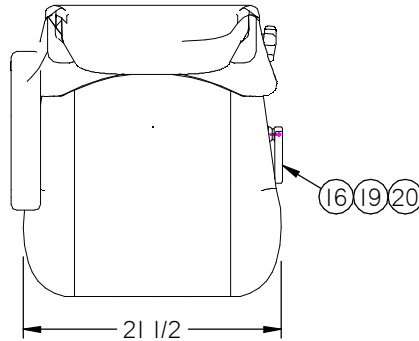

RECLINED POSITION

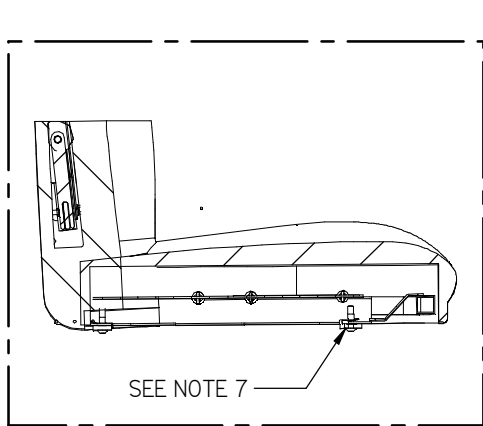

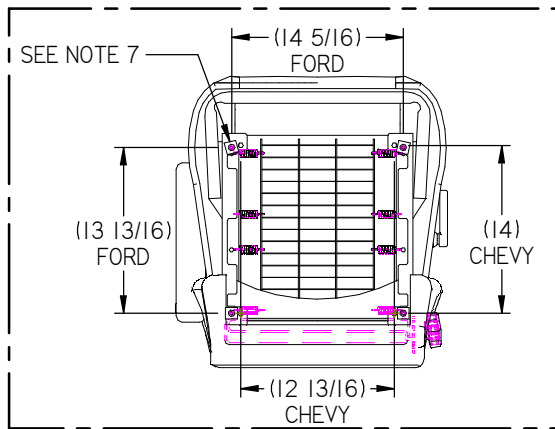

SECTION C-C



VIEW B-B

Tolerances Unless Otherwise Specified:  
Fraction: 1/8 +/- 1/4"  
Decimal: .XXX +/- 0.02"  
          XXX +/- 0.01"  
Angular +/- 1 Degree

UNSPECIFIED RADIUS ARE 1/8"

|   |   |                |   |
|---|---|----------------|---|
| DRAWING NAME:<br><b>ASSY,IP SHIELD DRVR,REC</b> |   |                |   |
| MATERIAL:                                       |  Freedman Seating Co.<br>4545 W. Augusta Blvd<br>Chicago, IL 60651 |                | PROJECTION<br> |
| SPECIFICATION:                                  | Author: _____   | REF. _____     | SUPERSEDES _____  |
| By: <b>Scmc</b>                                 | DATE: 12/2/2019   | CHECKED: _____ | APPROVED: _____   |
| SIZE: <b>C</b>                                  | DRAWING No. <b>71234</b>  | REV. <b>G</b>  |   |
| SCALE: NOT TO SCALE                             | BM  | CODE           | ISSUE DATE  |
|   |   | SHEET          | 2 of 2  |