

PLASTIC GARDEN SHED 6x4. 4FT

Instructions for Assembly

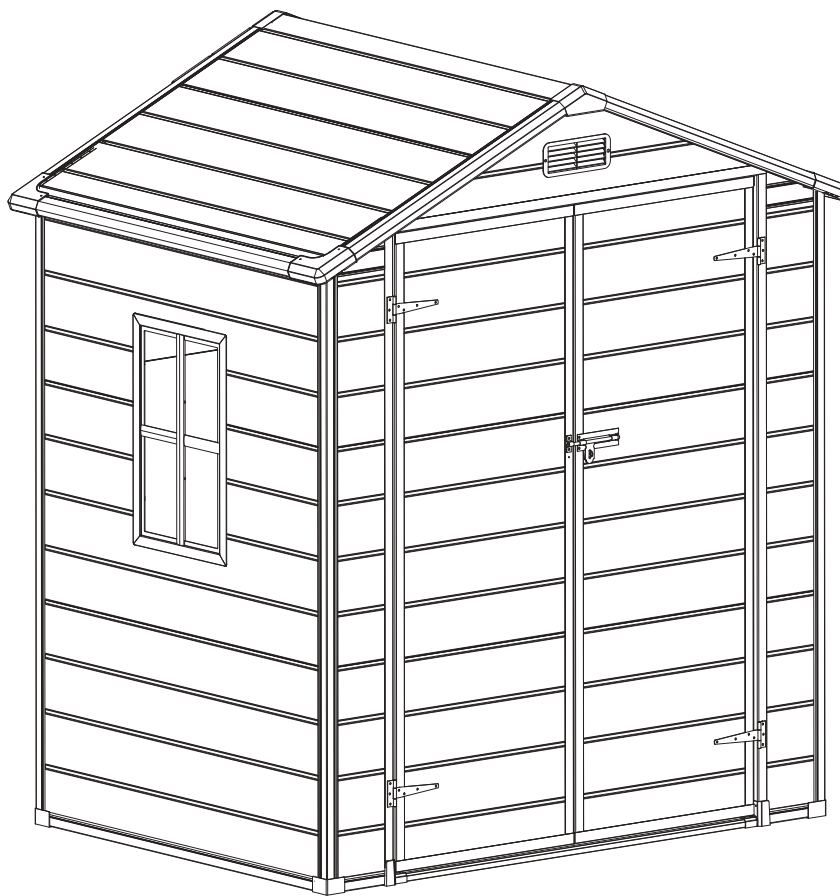

WARNING

Please read the instruction manual carefully before assembly.
Please assembly strictly in accordance with the instruction.
Please double-check to ensure that all parts of the package contents intact.
To avoid injury, work gloves are recommended during assembly.

SITE PREPARATION | PRÉPARATION DU SITE | PREPARACIÓN DEL LUGAR | VORBEREITUNG DES AUFSTELLUNGORTES | VOORBEREIDING VAN HET TERREIN | PREPARAZIONE DEL LUOGO DI ASSEMBLAGGIO | PREPARAÇÃO DO LOCAL

Level the ground surface | Nivelez la surface du sol | Nivela la superficie del suelo | Ebenen Sie die Bodenoberfläche | Maak de bodem vlak | Livellare la superficie del terreno | Nivela a superfície do solo

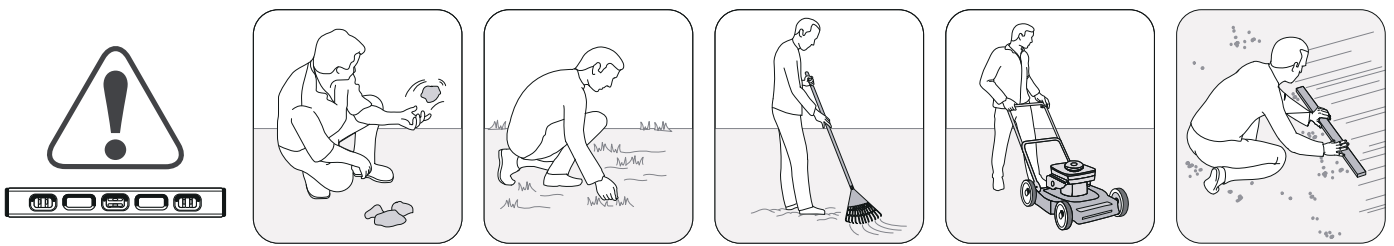

Recommendation: Construct a wooden or concrete base as a foundation | Recommandation: fabriquez une base en bois ou en béton en guise de fondation | Recomendación: construya una base de madera o de cemento a modo de cimiento | Empfehlung: Bauen Sie als Fundament eine Grundfläche aus Holz oder Beton | Aanbeveling: maak een houten of betonnen ondergrond als fundering | Raccomandazione: Costruire una base di legno o di cemento come fondamenta | Recomendação: Construa uma base de madeira ou de cimento como fundação

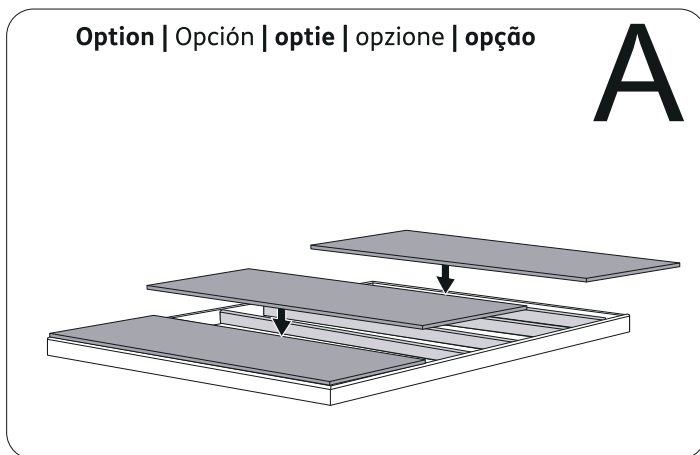

External floor measurements are: | Les mesures externes de la étage sont: | Las medidas del suelo externo son: | Die Außen-Bodenmaße betragen: | De afmetingen van de externe vloer zijn: | Le dimensioni esterne del pavimento sono: | As medidas externas do chão são:

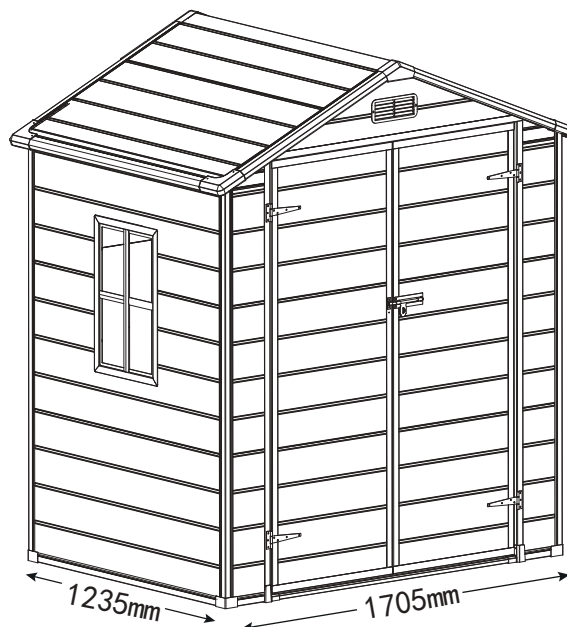

BEFORE STARTING ASSEMBLY | AVANT DE COMMENCER LE MONTAGE | ANTES DE EMPEZAR EL ARMADO | VOR MONTAGEBEGINN | VOORDAT U BEGINT TE MONTEREN | PRIMA DI INIZIARE L'ASSEMBLAGGIO | ANTES DE INICIAR A MONTAGEM

Read the care and safety guidelines at the end of this manual | Check to ensure that there are no missing or damaged parts BEFORE starting or arranging assembly | Remove all parts from the package(s) and spread them out on a clean work surface | Review all assembly instructions | Assemble all the parts according to the directions in this manual. Do not skip any steps.

Lisez les instructions de précaution et de sécurité à la fin de ce manuel | Assurez-vous qu'il n'y a pas de pièces manquantes ou endommagées AVANT de commencer ou d'organiser l'assemblage | Retirez toutes les pièces du/des paquet(s) et étalez-les sur une surface de travail propre | Lisez toutes les instructions de montage | Assemblez toutes les pièces selon les instructions de ce manuel. Ne sautez aucune étape.

Lea las instrucciones de precauciones y seguridad que están al final de este manual | Asegúrese de que no faltan piezas ni están dañadas ANTES de comenzar o disponer el montaje | Saque todas las piezas del paquete o paquetes y póngalas sobre una superficie de trabajo limpia | Revise todas las instrucciones de montaje | Monte todas las piezas según las instrucciones de este manual. No se saltee ningún paso.

Lesen Sie die Sicherheitsrichtlinien am Ende des Benutzerhandbuchs durch | Prüfen Sie bitte VOR dem Zusammenbau, dass keine Teile beschädigt sind oder fehlen | Nehmen Sie alle Teile aus der Verpackung und breiten Sie sie auf einer sauberen Arbeitsfläche aus | Gehen Sie noch einmal die komplette Aufbauanleitung durch | Bauen Sie alle Teile entsprechend der Anleitung in diesem Handbuch zusammen. Lassen Sie dabei keinen Arbeitsschritt aus.

Lees de richtlijnen voor zorg en veiligheid achterin deze handleiding | Controleer dat er geen onderdelen mankeren, of beschadigd zijn, VOORDAT u met de montage begint | Haal alle onderdelen uit het pakket (of uit de pakketten) en leg ze open op een schoon werkoppervlak | Bekijk alle montagehandleidingen | Monteer alle onderdelen volgens de aanwijzingen van deze handleiding. Sla geen stappen over.

Leggere le linee guida di assistenza e sicurezza alla fine di questo manuale | Assicurarsi che non ci siano parti mancanti o danneggiate PRIMA di iniziare l'assemblaggio | Estrarre tutti i componenti dall'imballo e posizzarli su una superficie di lavoro pulita | Consultare tutte le istruzioni di montaggio | Assemblare tutti i componenti secondo le istruzioni contenute nel manuale. Non saltare nessuna fase.

Leia as diretrizes de cuidados e segurança que constam da parte final deste manual | Verifique para se assegurar de que não há peças em falta ou danificadas ANTES de começar a preparar a montagem | Retire todas as peças da embalagem e espalhe-as numa superfície de trabalho limpa | Reveja todas as instruções de montagem | Monte todas as peças de acordo com as instruções do manual. Não salte quaisquer passos.

REQUIRED TOOLS | OUTILS EXIGÉS | HERRAMIENTAS NECESARIAS | BENÖTIGTE WERKZEUGE | BENODIGD GEREEDSCHAP | ATTREZZATURA OCCORRENTE | FERRAMENTAS NECESSÁRIAS



SPATULA | SPATULE | ESPÁTULA | SPACHTEL | SPATEL | SPATOLA | ESPÁTULA

- Use spatula (part “SG8”) for easier insertion of panel into profile.
- Utilisez la spatule (partie “SG8”) pour une meilleure insertion du panneau dans le profil.
- Utilice una espátula (pieza “SG8”) para una mejor inserción del panel en el perfil.
- Benutzen Sie den Spachtel (Bezeichnung “SG8”), um die Platten leichter in die Nut einführen zu können.
- Gebruik spatel (onderdeel SG8) voor het gemakkelijk invoeren van het paneel in het profiel.
- Utilizzare la spatola (parte SG8) per inserire il pannello più facilmente nel profilo.
- Utilize uma espátula (peça “SG8”) para facilitar a inserção do painel no perfil.

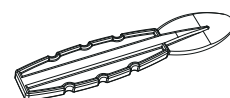

SG8 x2



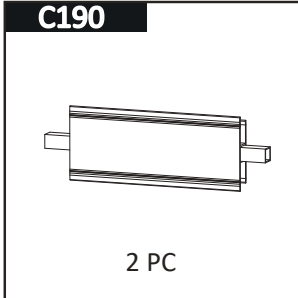
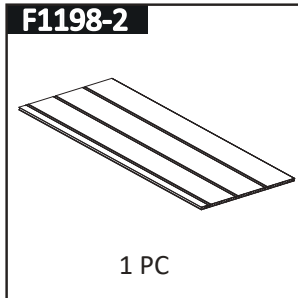
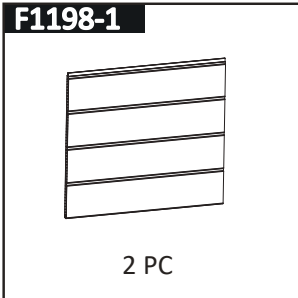
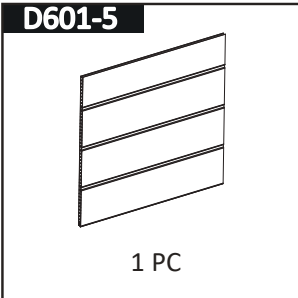
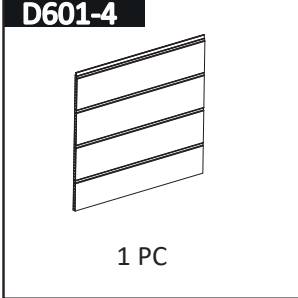
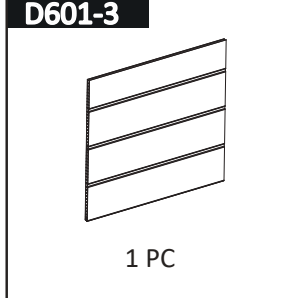
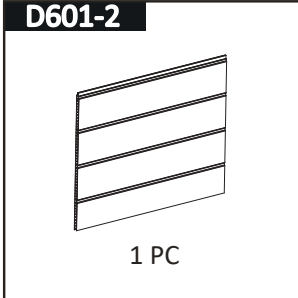
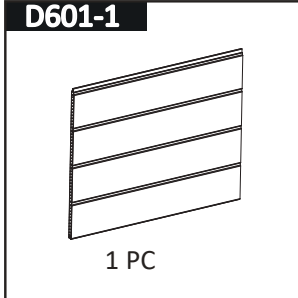
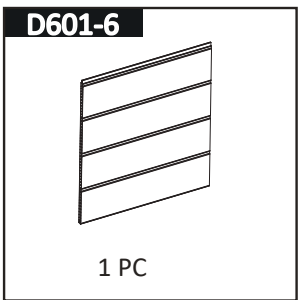
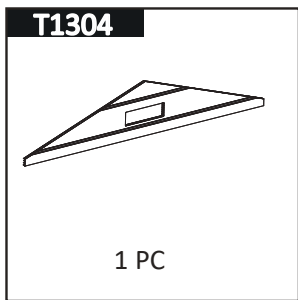
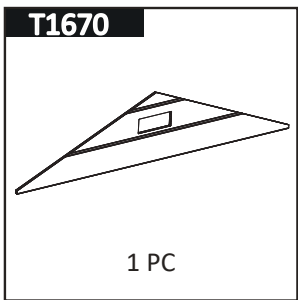
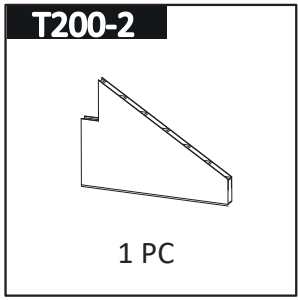
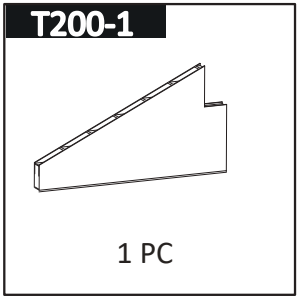
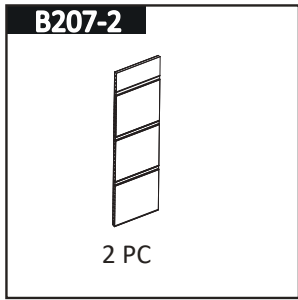
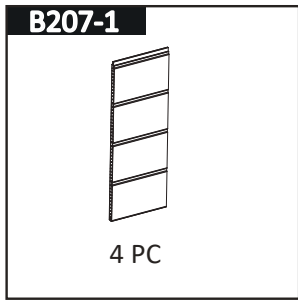
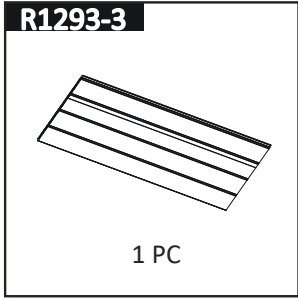
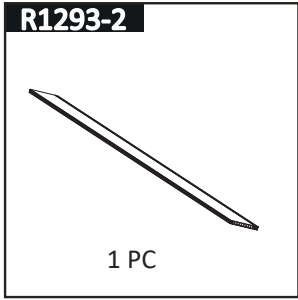
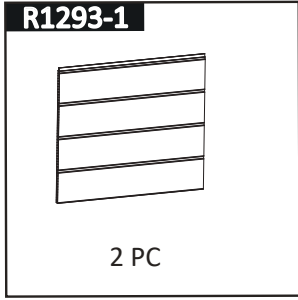
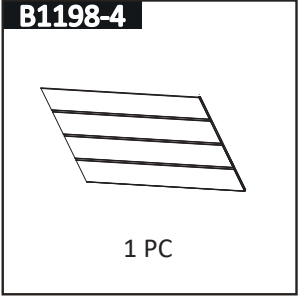
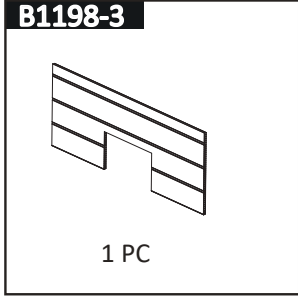
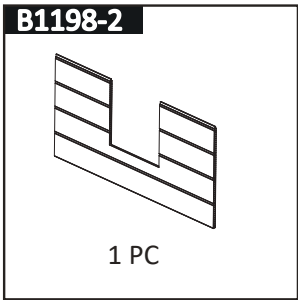
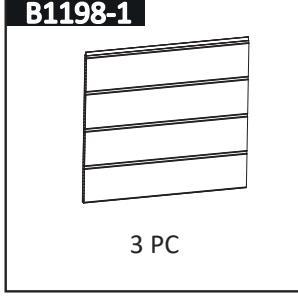
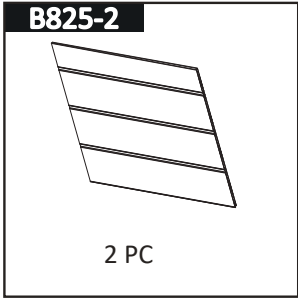
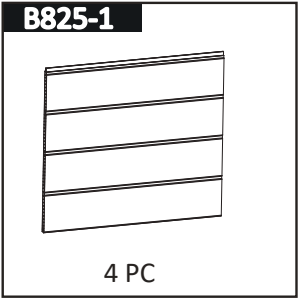

ASSEMBLY REQUIRES TWO PEOPLE | LE MONTAGE DOIT ÊTRE EFFECTUÉ PAR DEUX PERSONNES | SE NECESITAN DOS PERSONAS PARA ARMARLO | ZWEI PERSONEN ZUR MONTAGE NOTWENDIG | MONTAGE VEREIST TWEE PERSONEN | L'ASSEMBLAGGIO RICHIEDE DUE PERSONE | A MONTAGEM EXIGE DUAS PESSOAS

PART

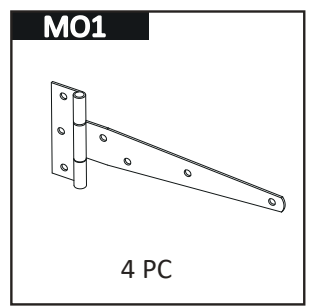
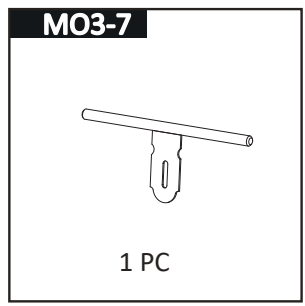
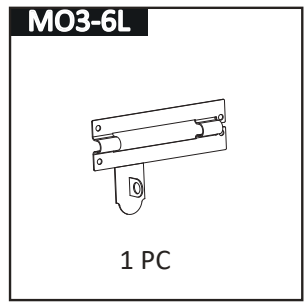
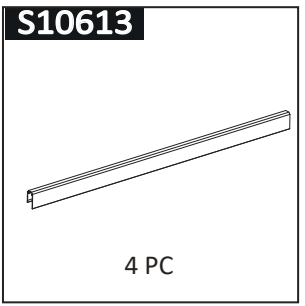
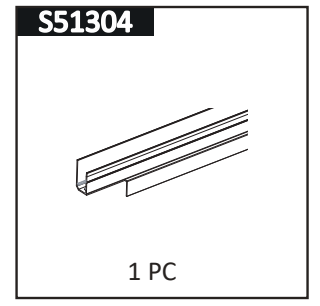
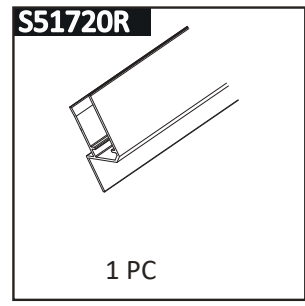
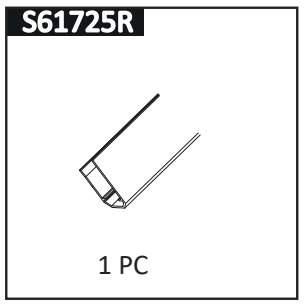
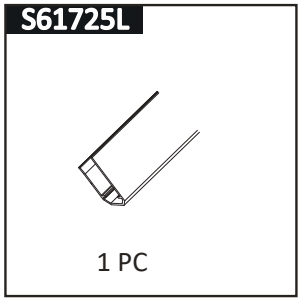
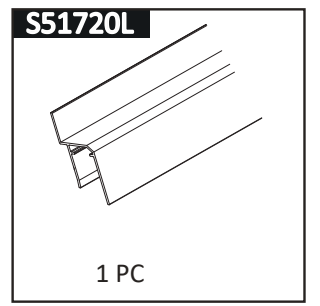
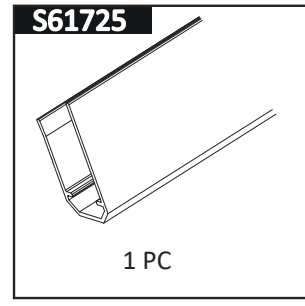
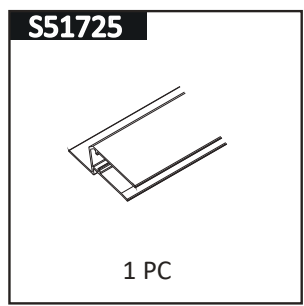
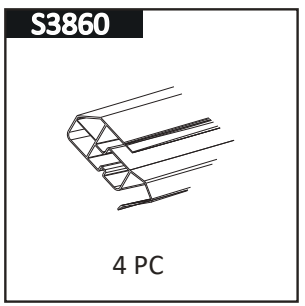
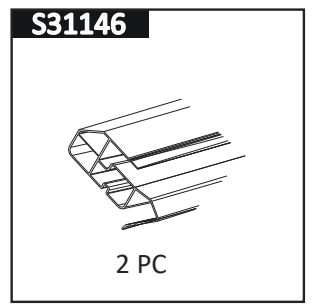
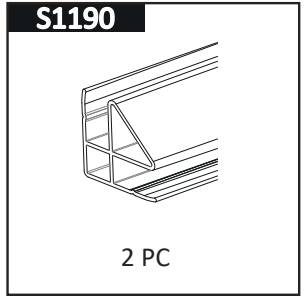
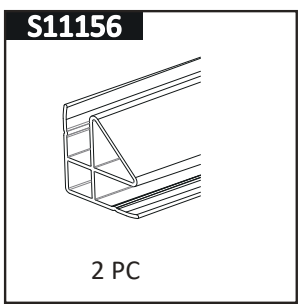
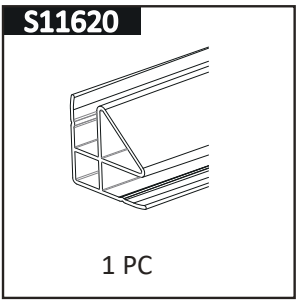
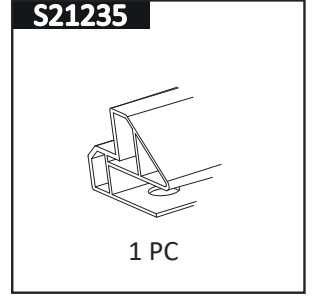
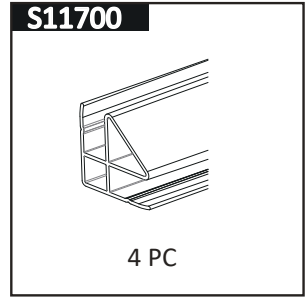
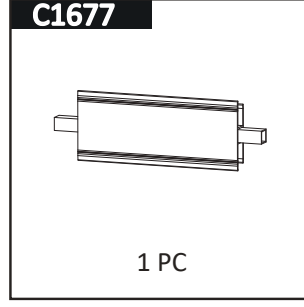
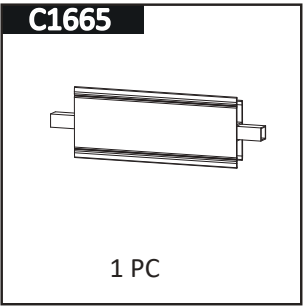
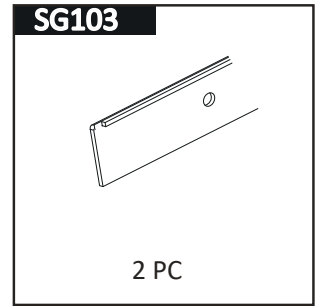
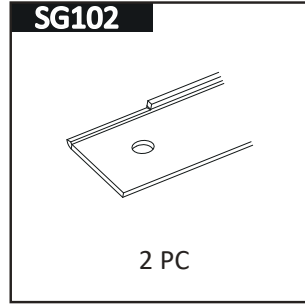
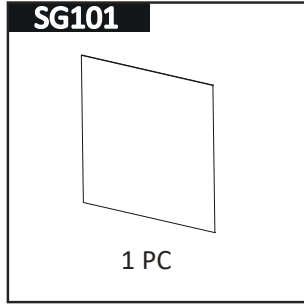
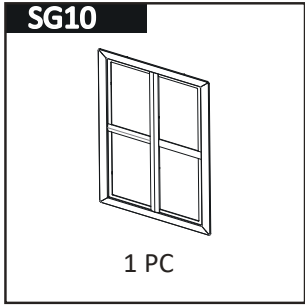

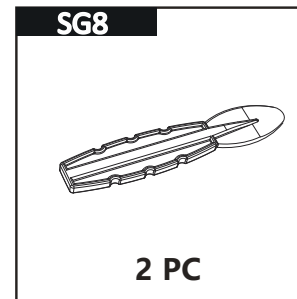
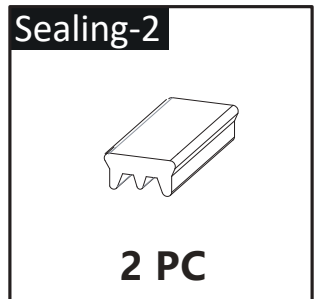
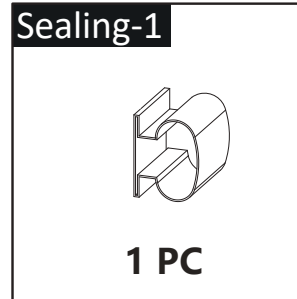
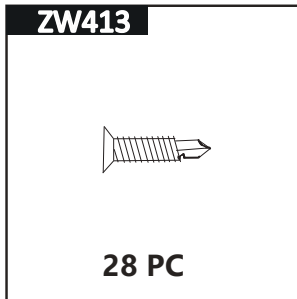
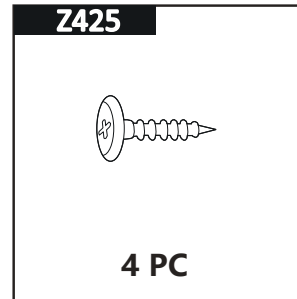
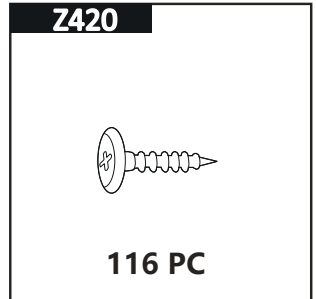
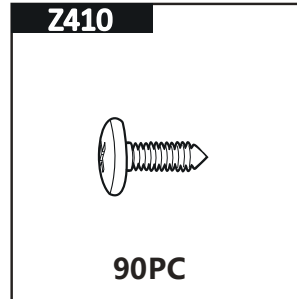
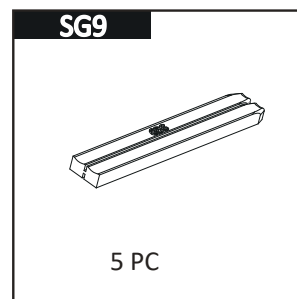
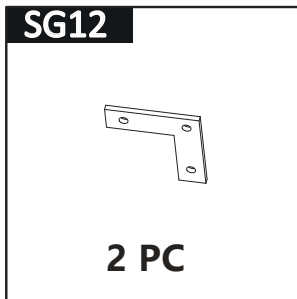
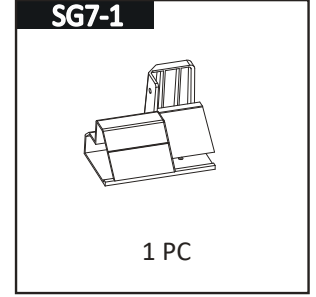
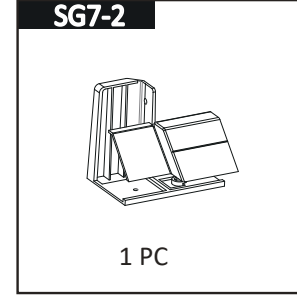
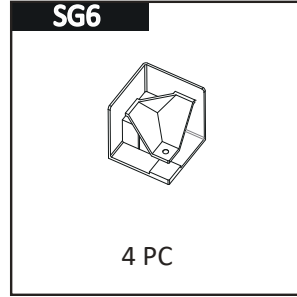
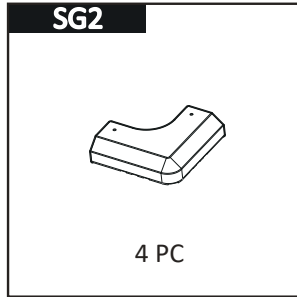
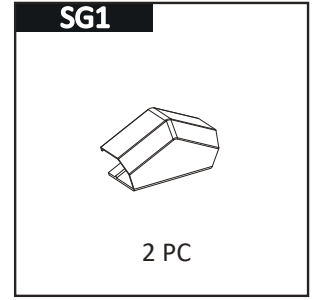
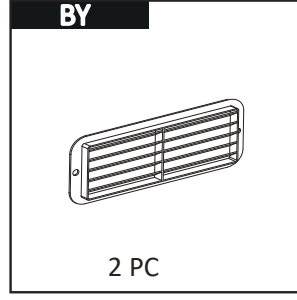
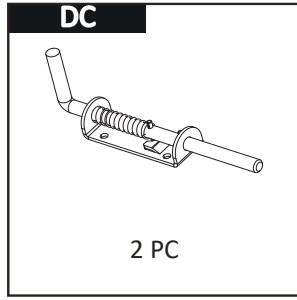
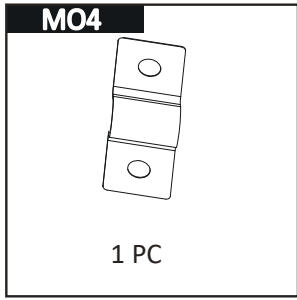



- Use spatula  (part "SG8") for easier insertion of panel into profile
- Please ensure the panels are all installed on position before screwing



ROOF PARTS

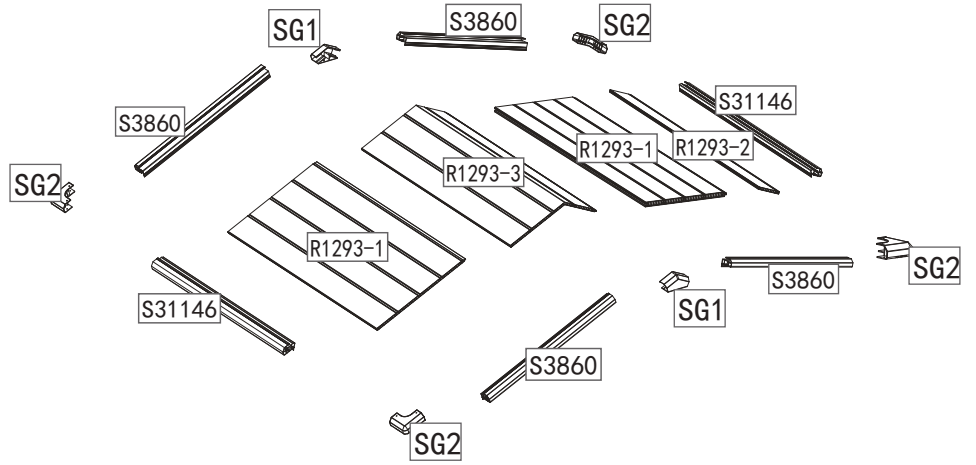

WALL AND WINDOW PARTS

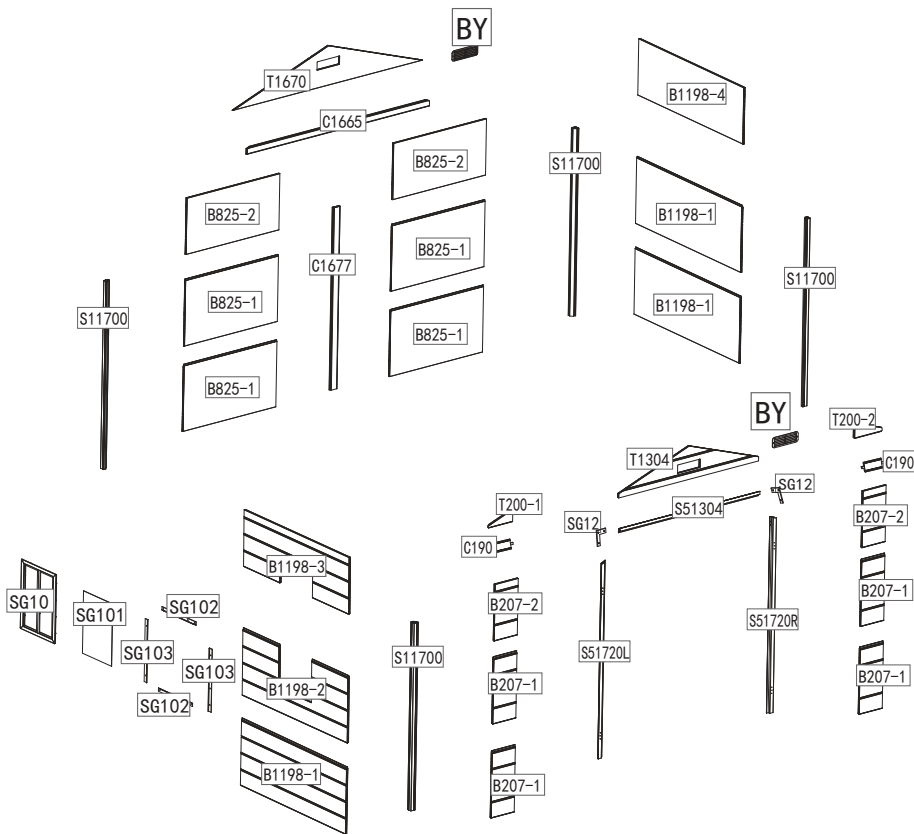

DOOR PARTS

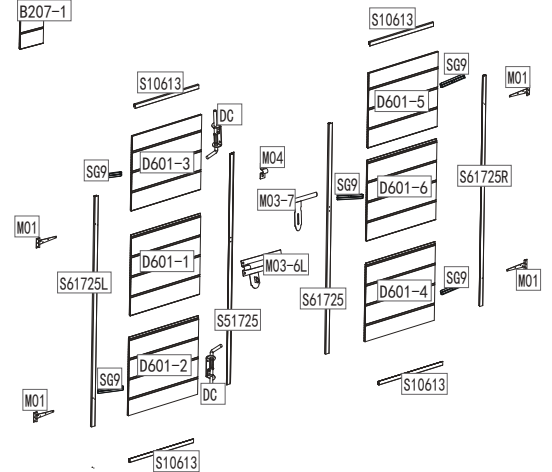

FLOOR PARTS

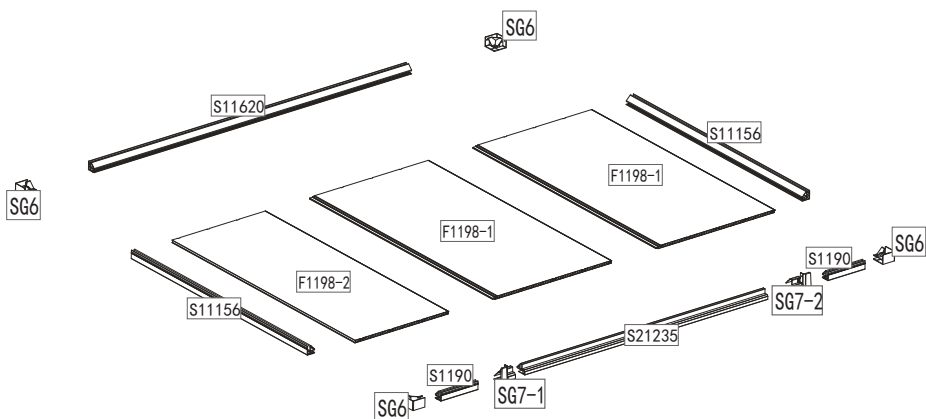

FLOOR ASSEMBLY

● Use spatula (part "SG8") for easier insertion of panel into profile



Note: The crease line of the floor must be underneath

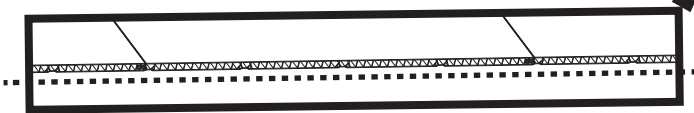
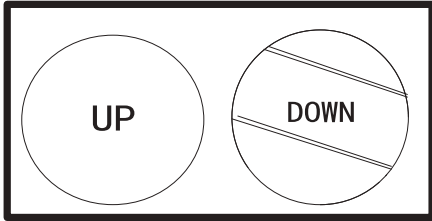

● The floor boards must be straight

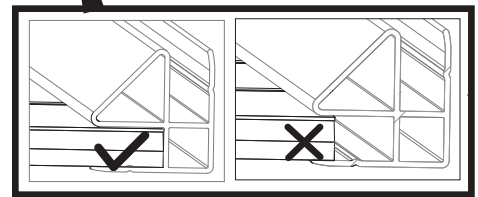

● Fully fit the panel inside the profile

Step 1

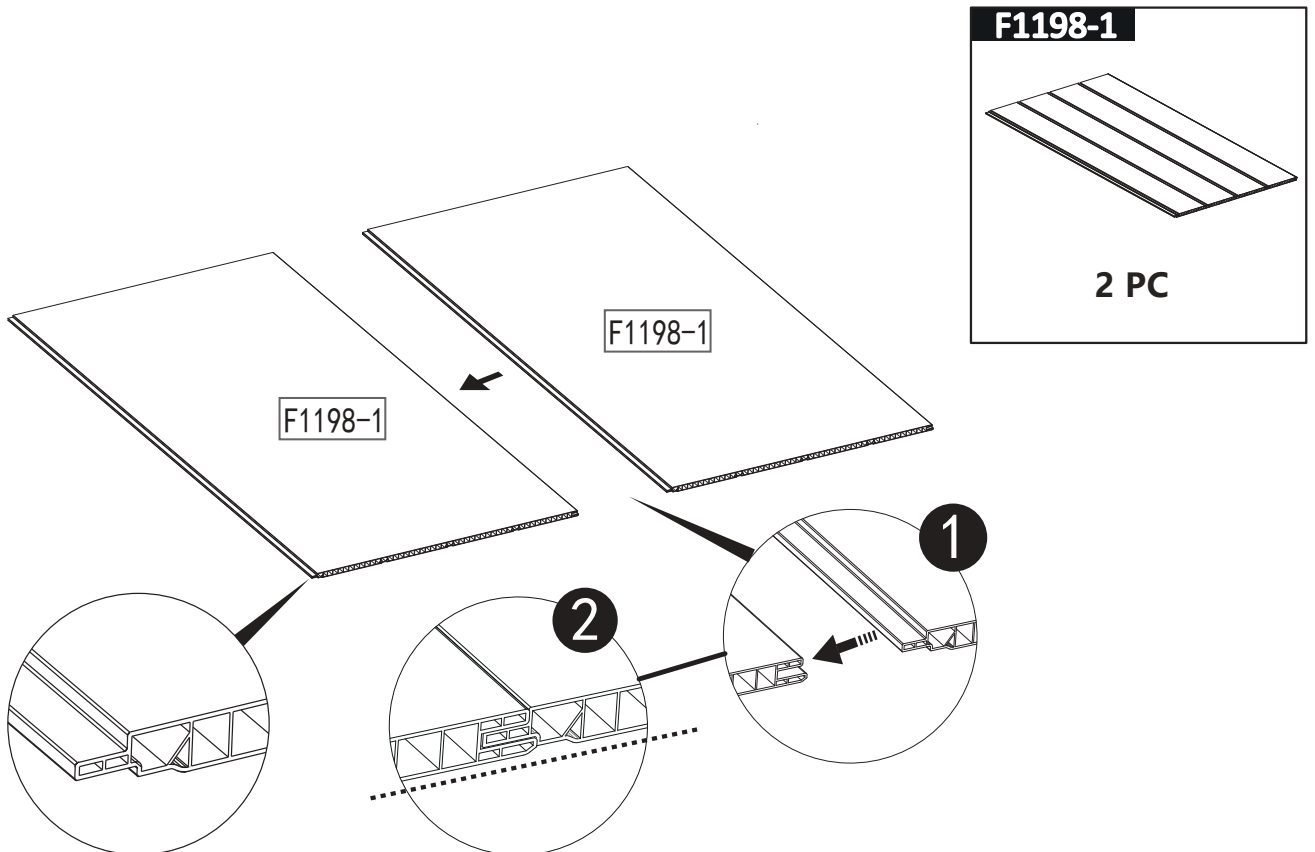

Step 2

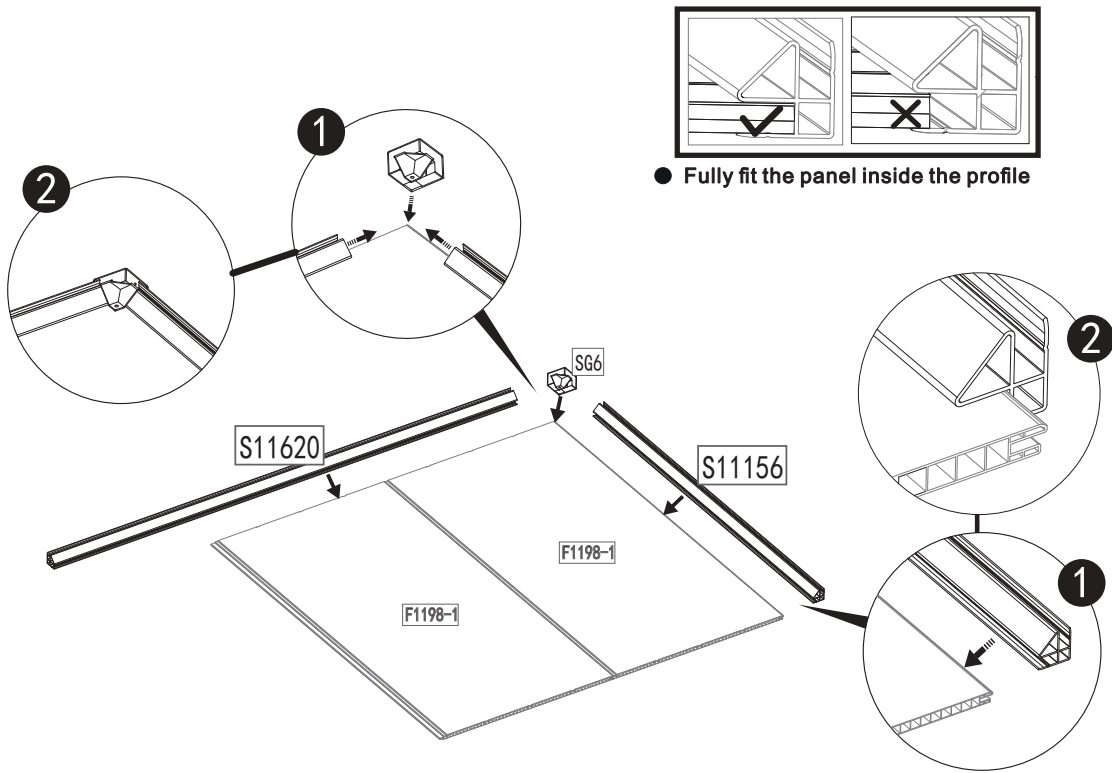

- S11620**
1 PC
- S11156**
1 PC
- SG6**
1 PC
- SG8**

Step 3

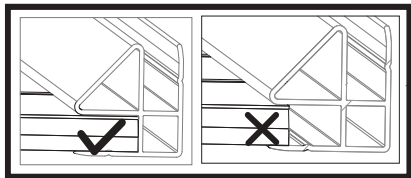

● Fully fit the panel inside the profile

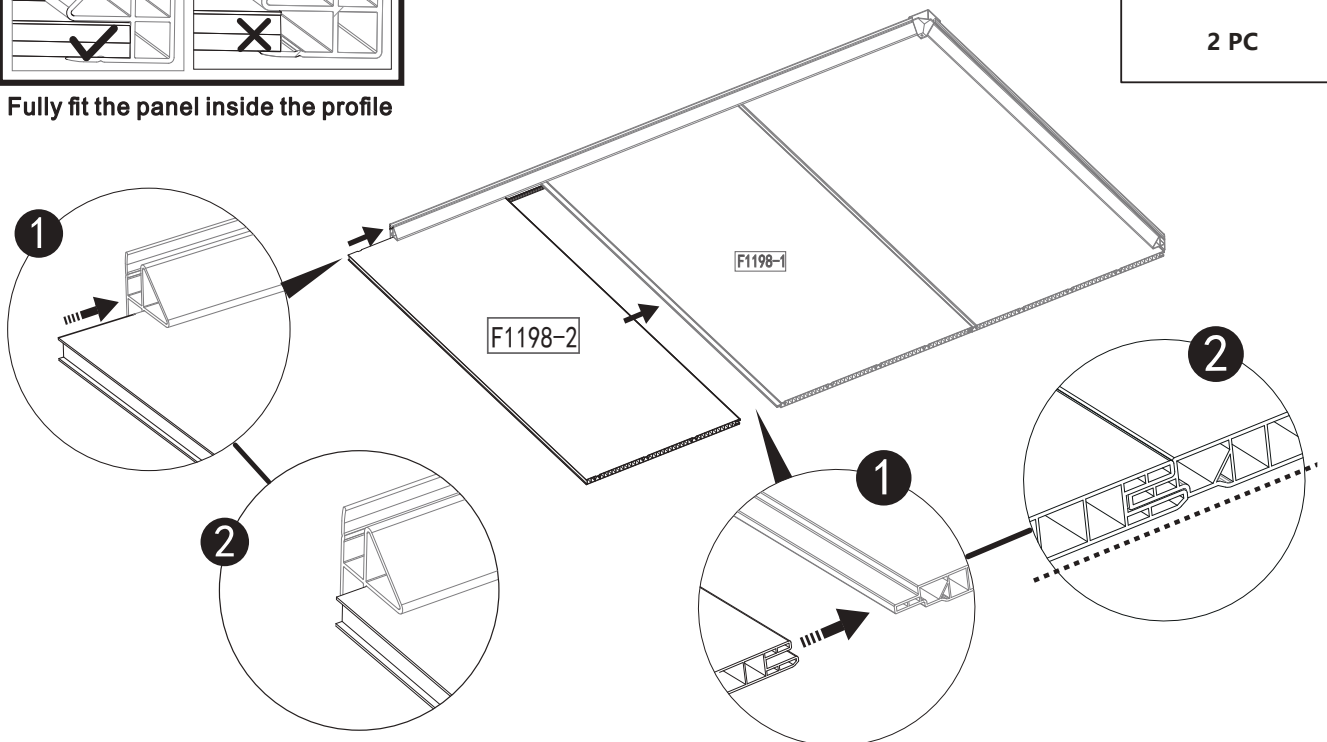
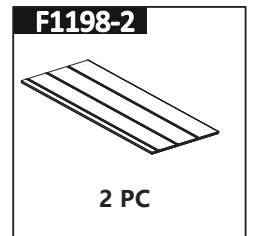
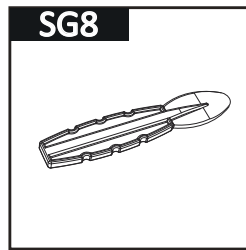

Step 4

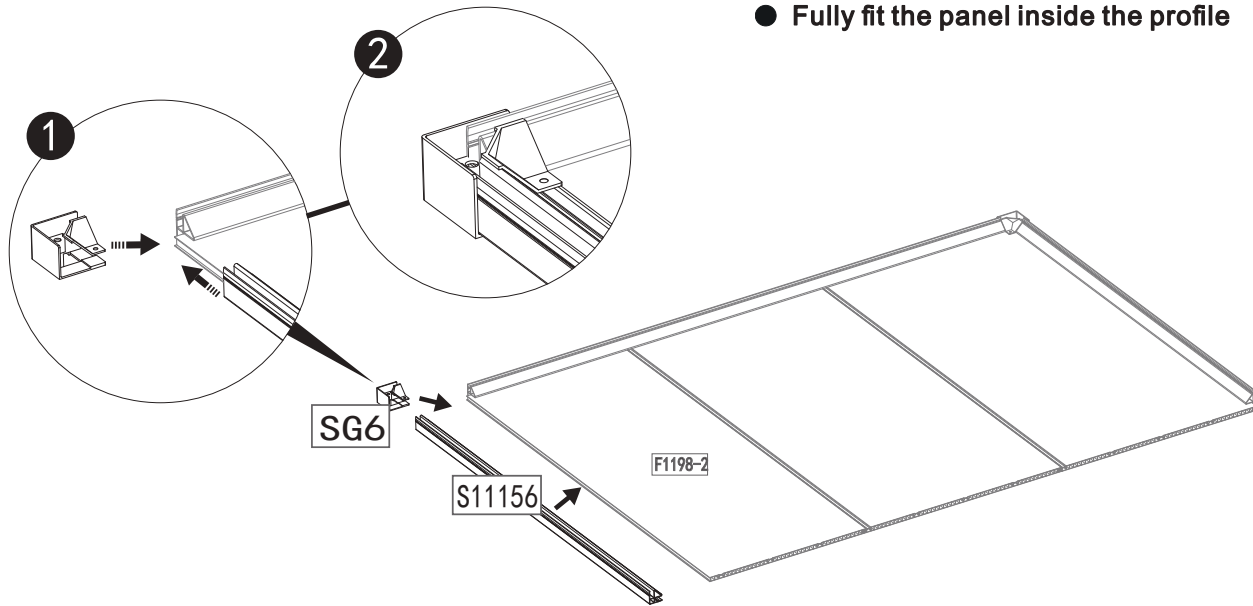

S11156

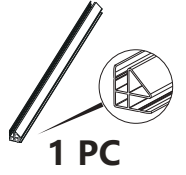

SG6

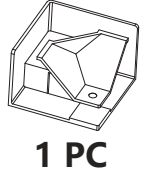

SG8

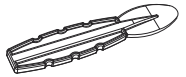

Step 5

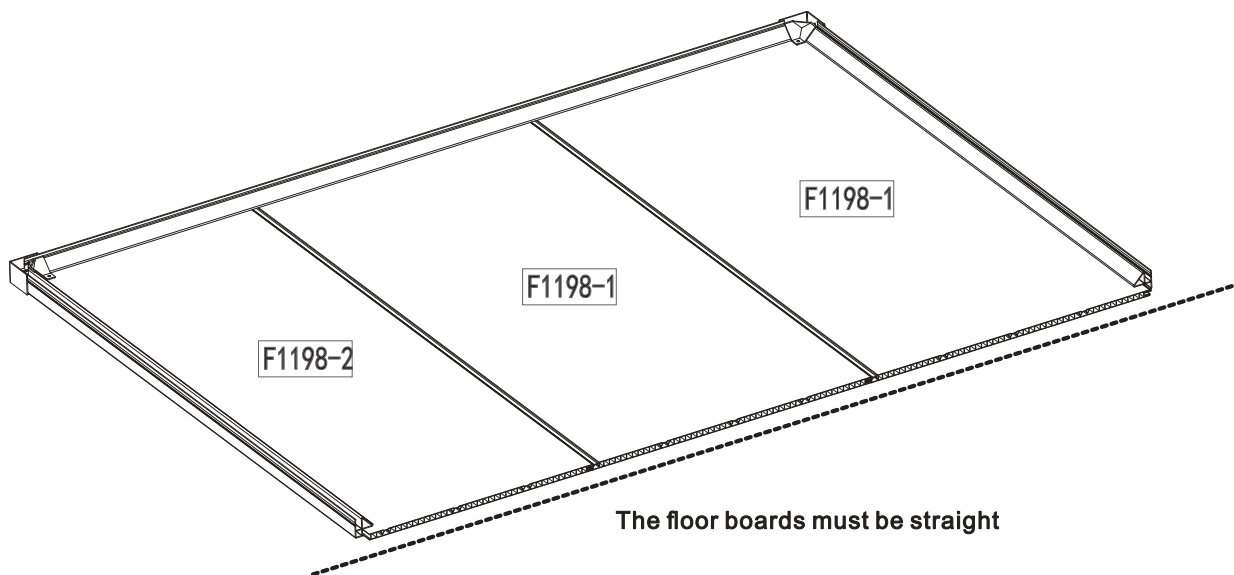

Step 6

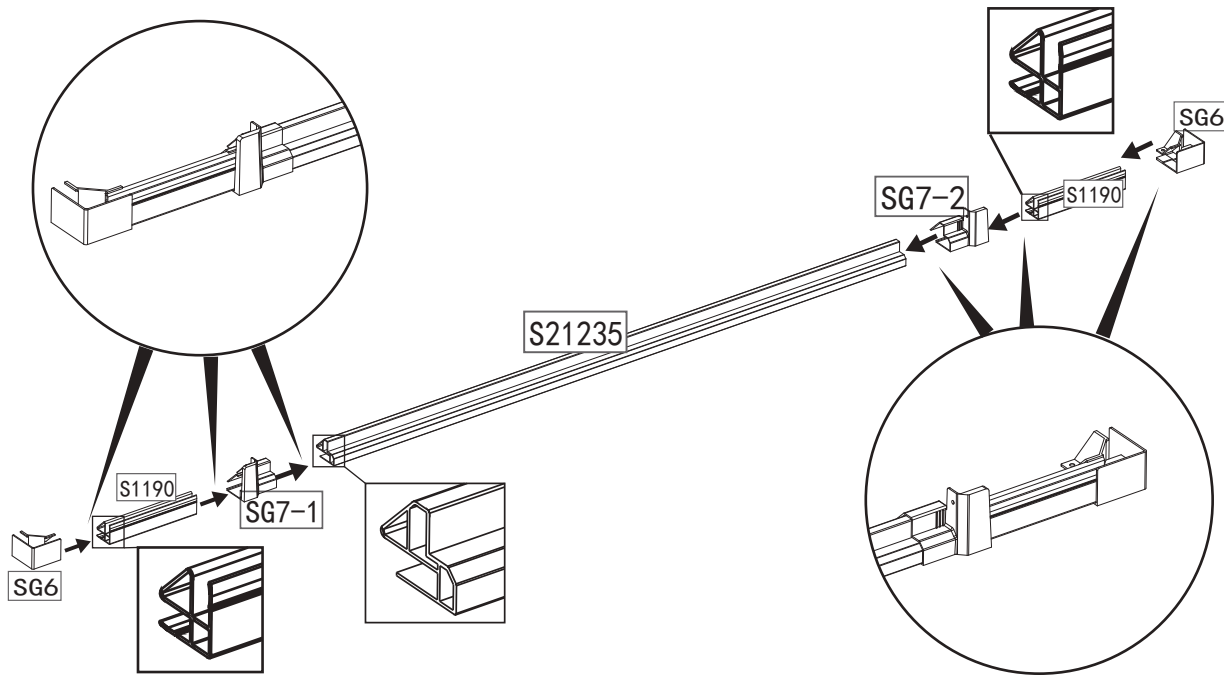

SG6		2 PC
S1190		2 PC
S21235		1 PC
SG7-2		1 PC
SG7-1		1 PC

Step 7

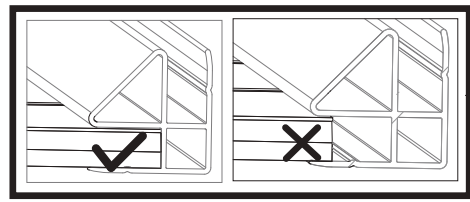

● Fully fit the panel inside the profile

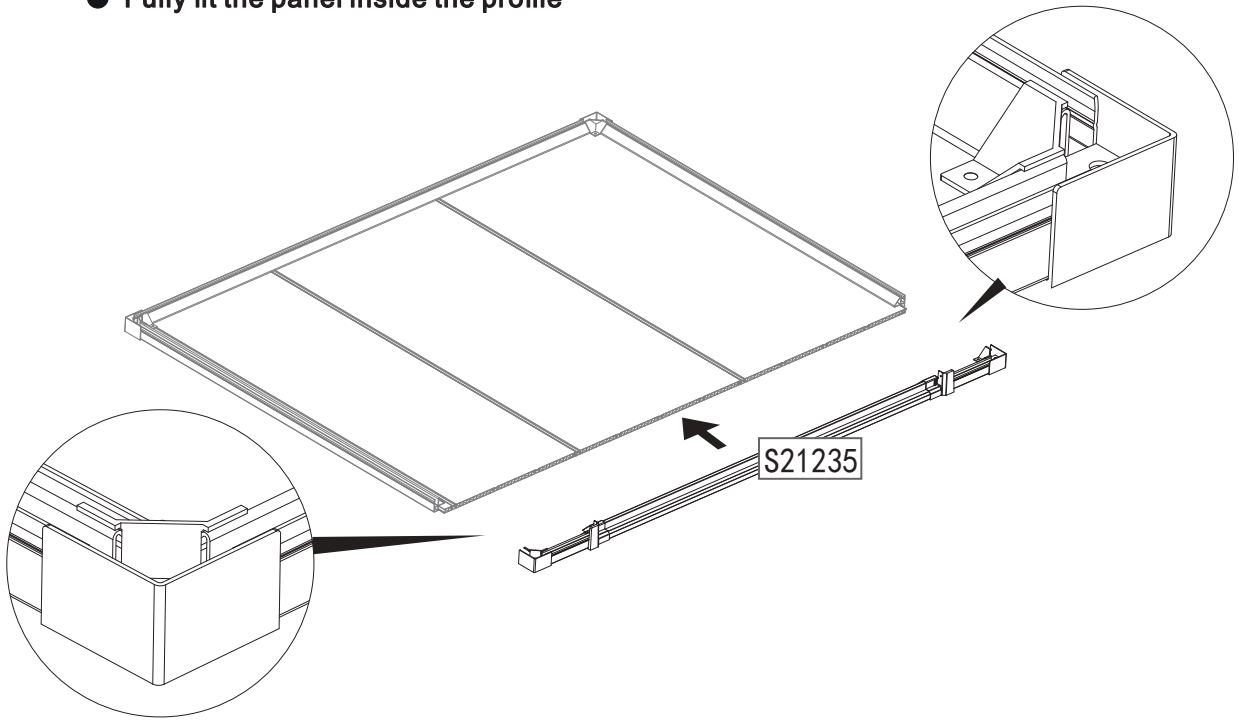
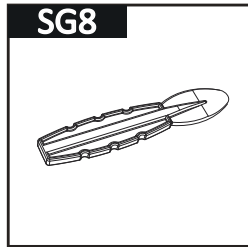
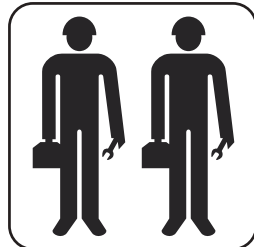

Step 8

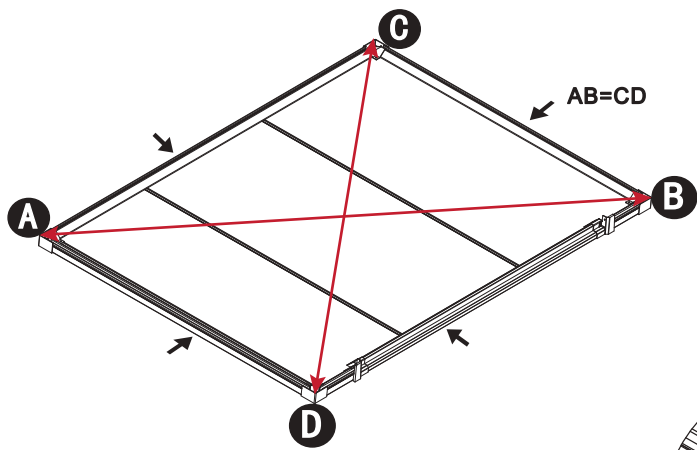

Z410

4 PC

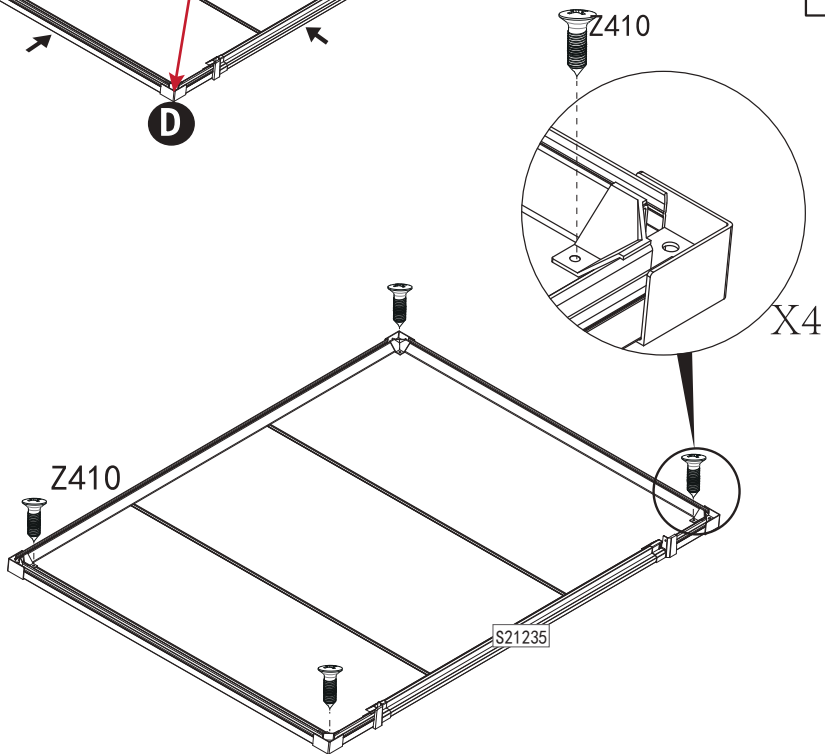

Step 9

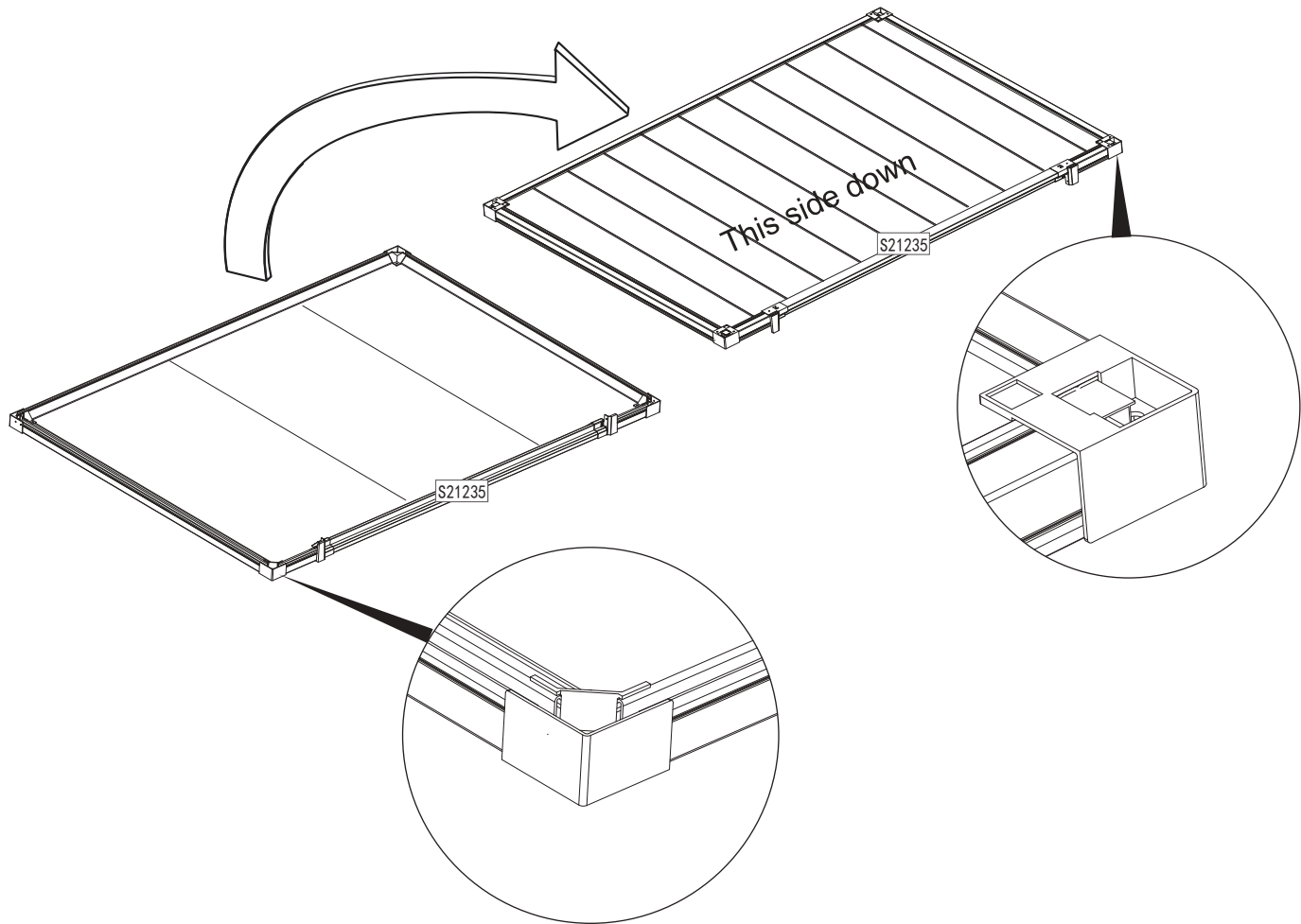

Step 10

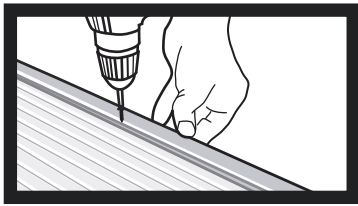

Screw along the marked lines in profile

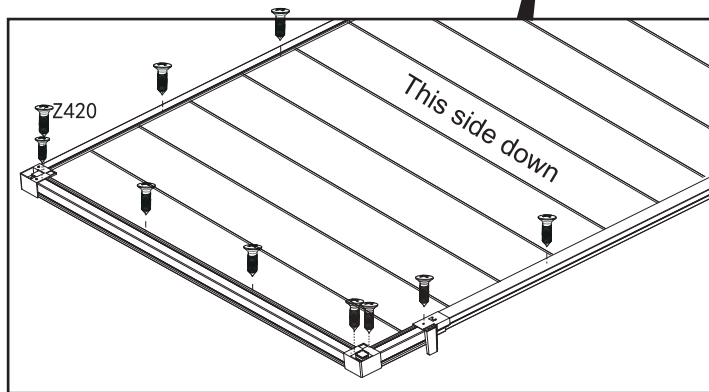
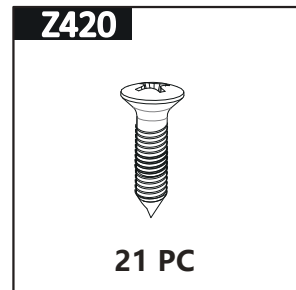
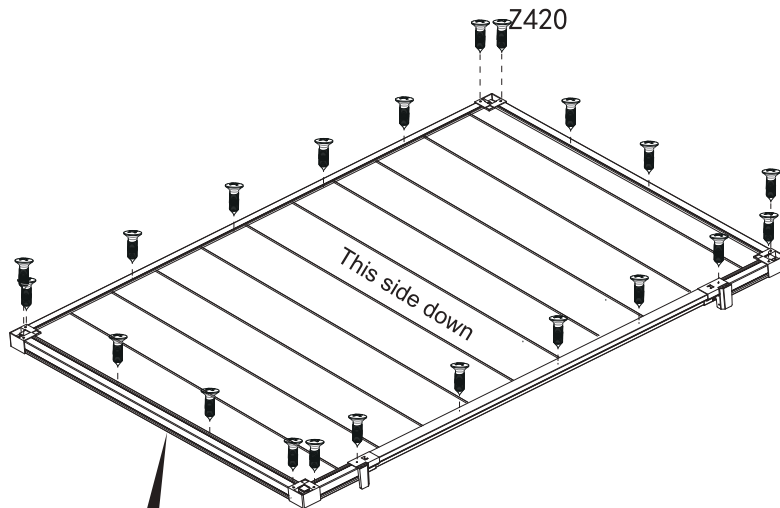

Step 11

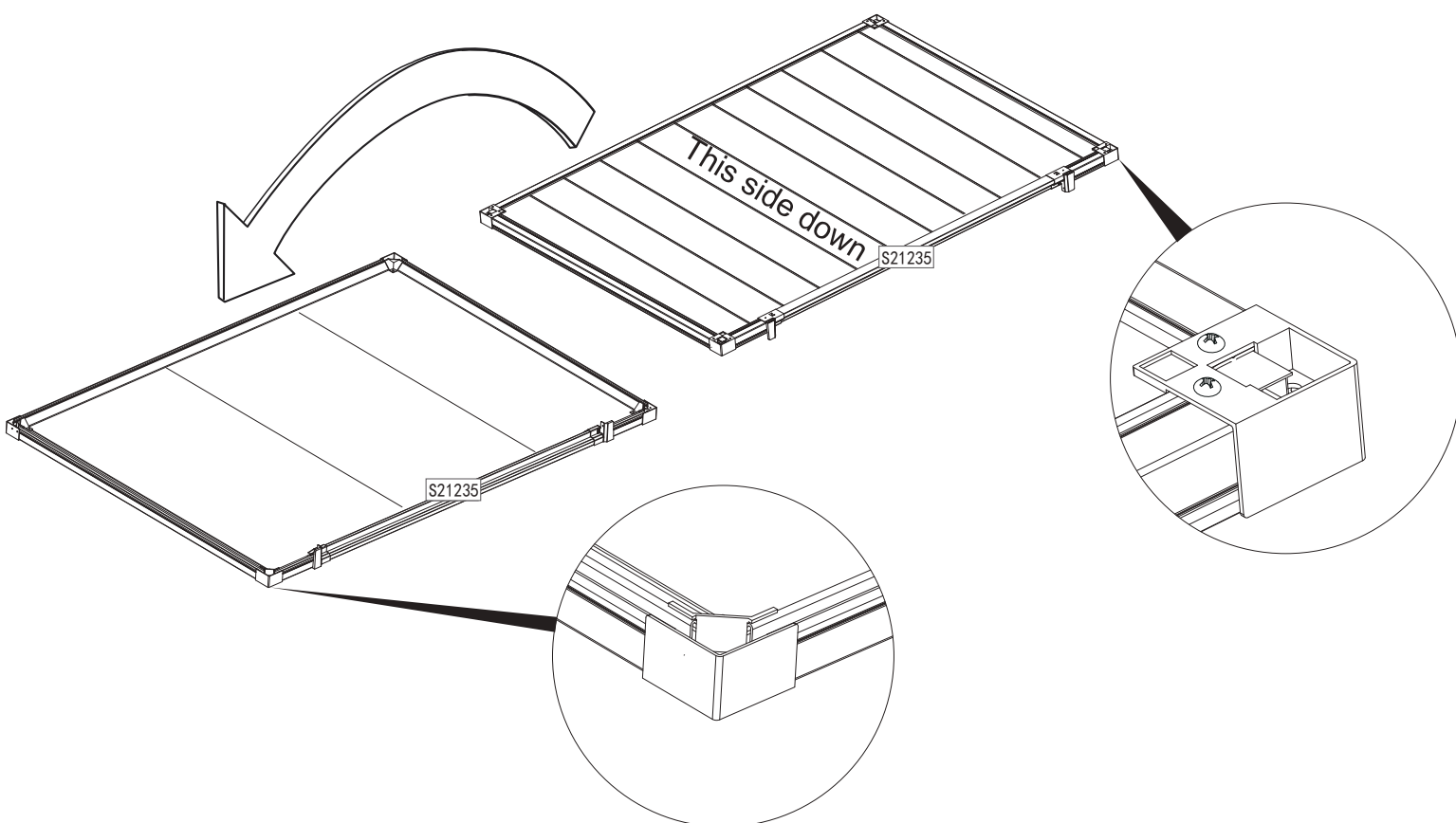

FLOOR ASSEMBLY

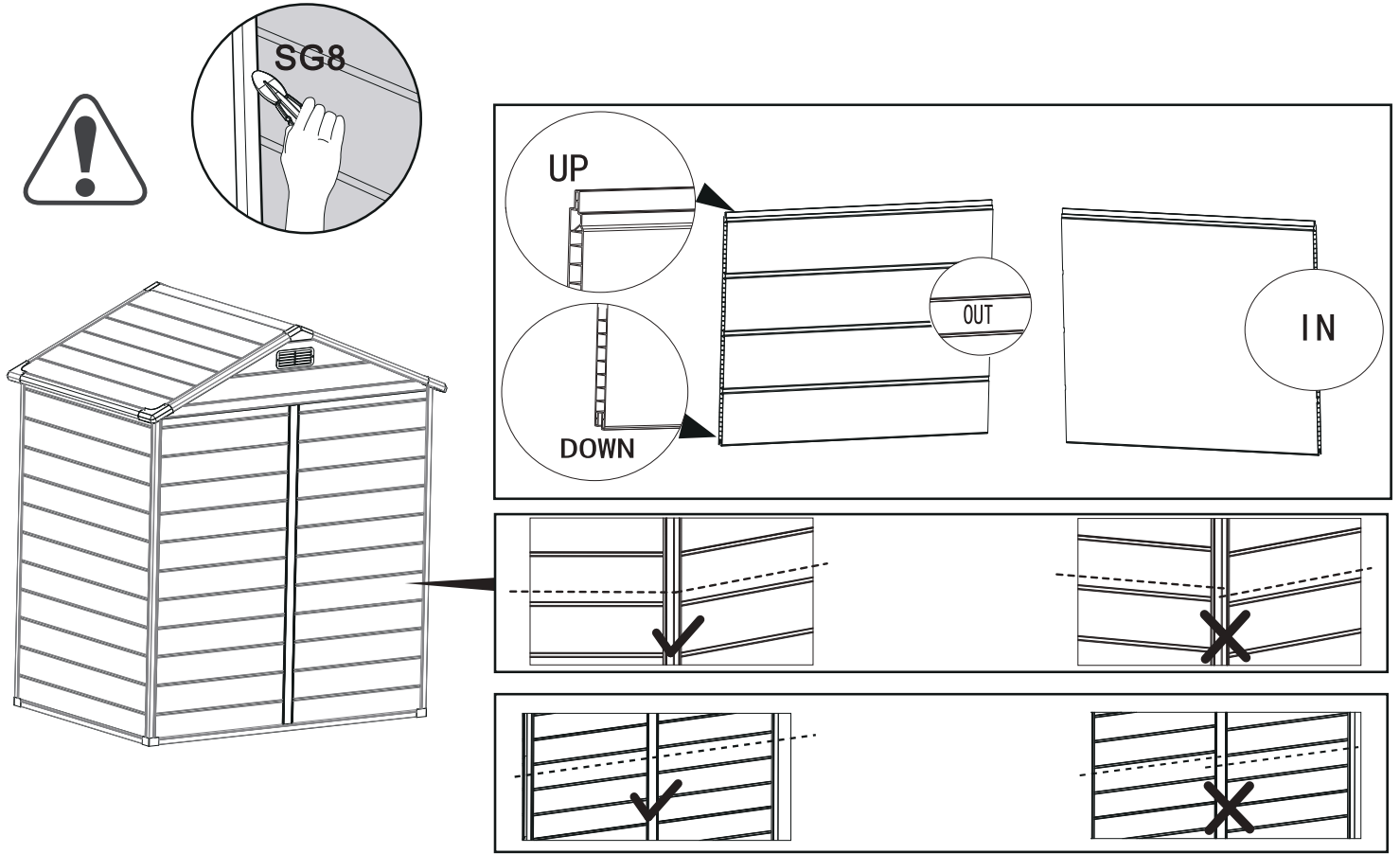

Step 12

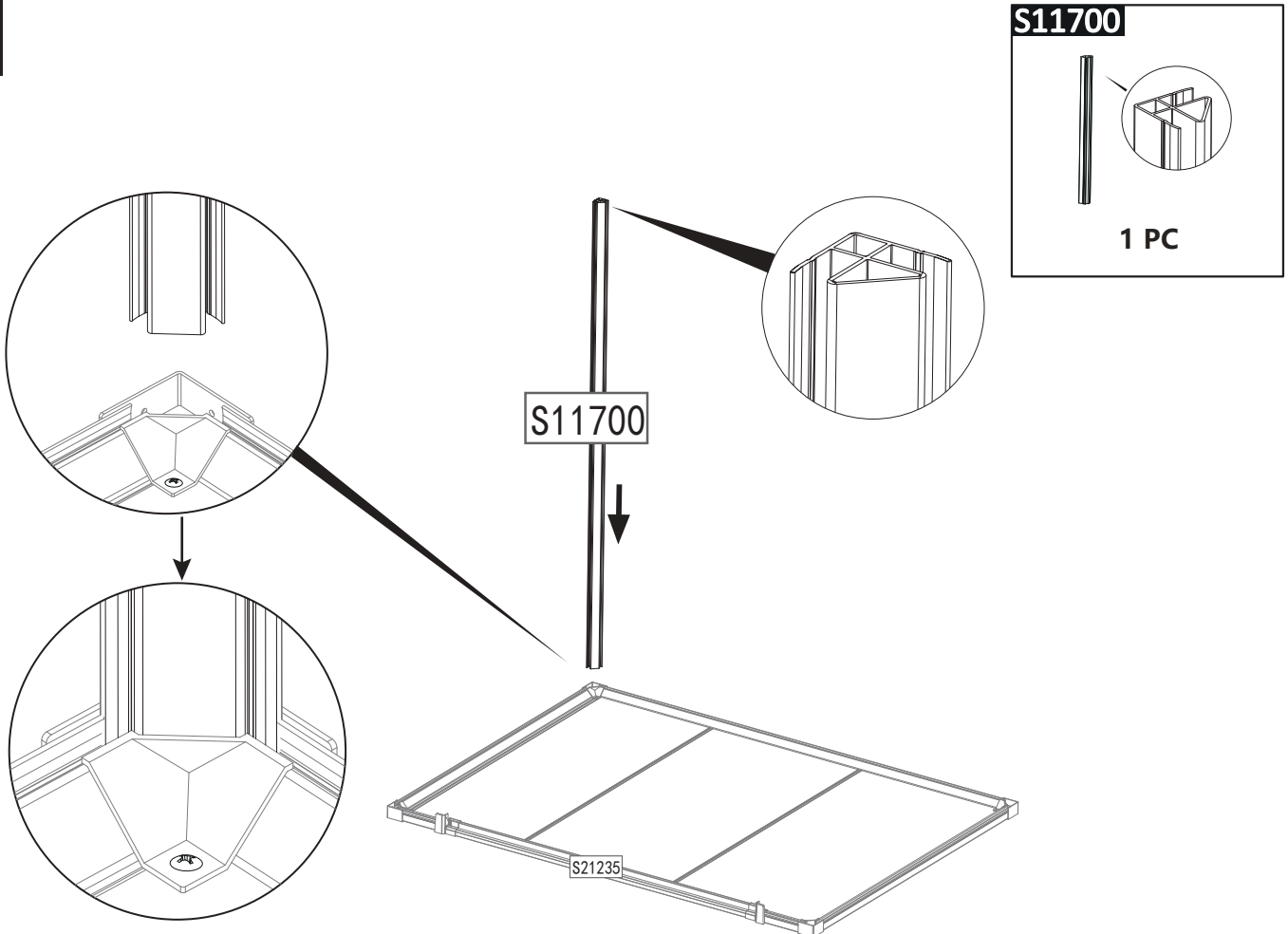

Step 13

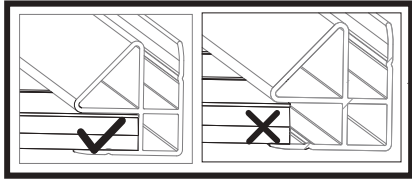

● Fully fit the panel inside the profile

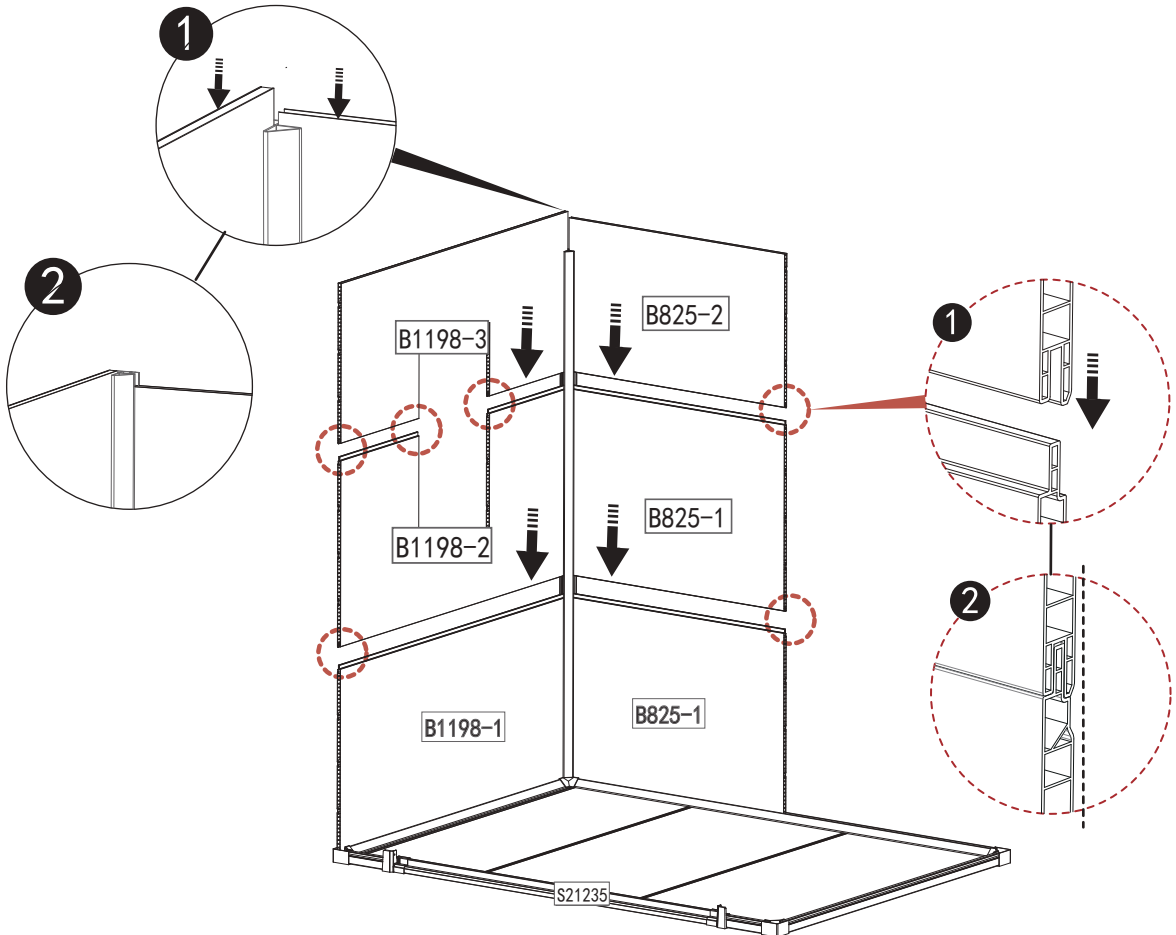
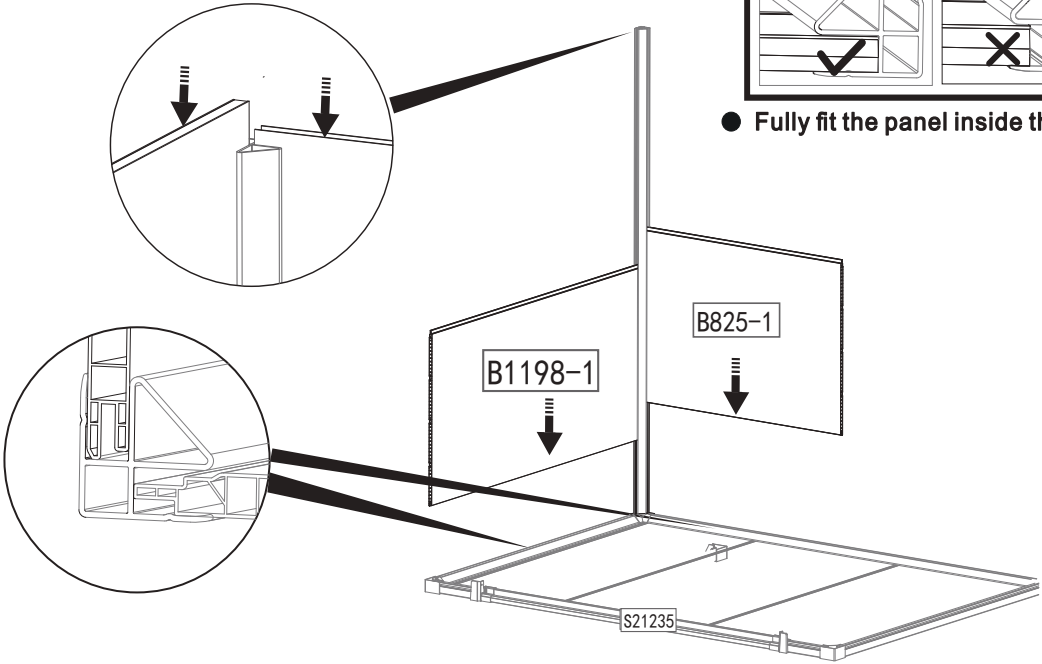

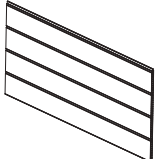
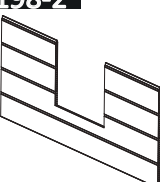
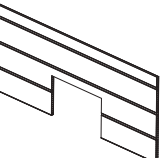
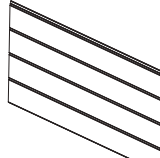
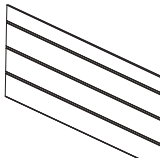
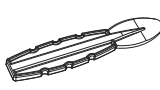
- B1198-1**

 1 PC
- B1198-2**

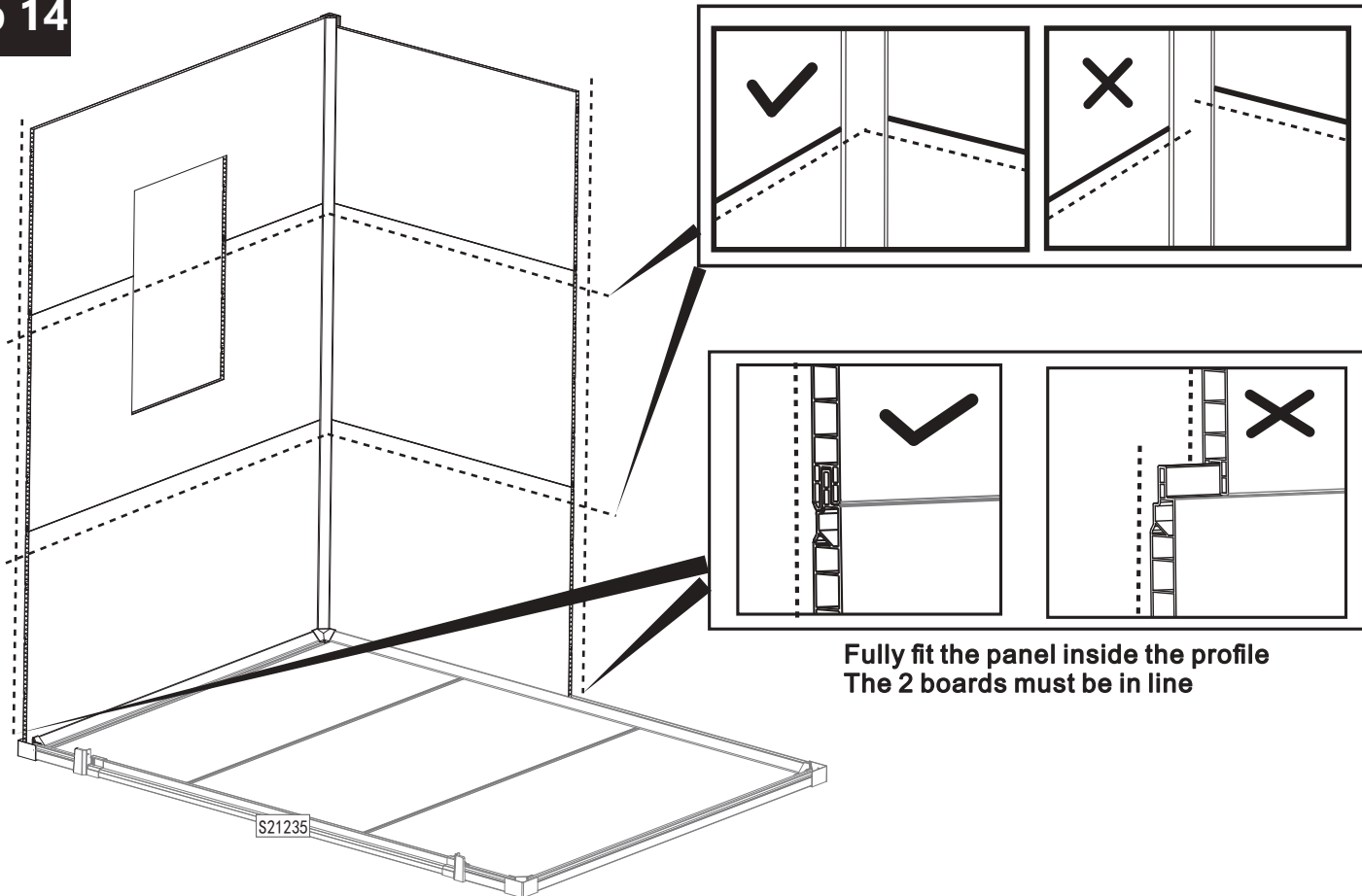
 1 PC
- B1198-3**

 1 PC
- B825-1**

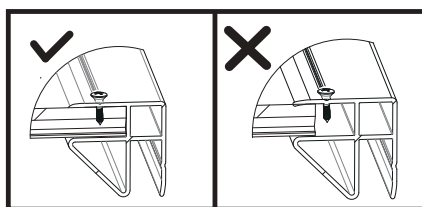
 1 PC
- B825-2**

 1 PC
- SG8**

Step 14



Step 15



Screw along the marked lines in profile

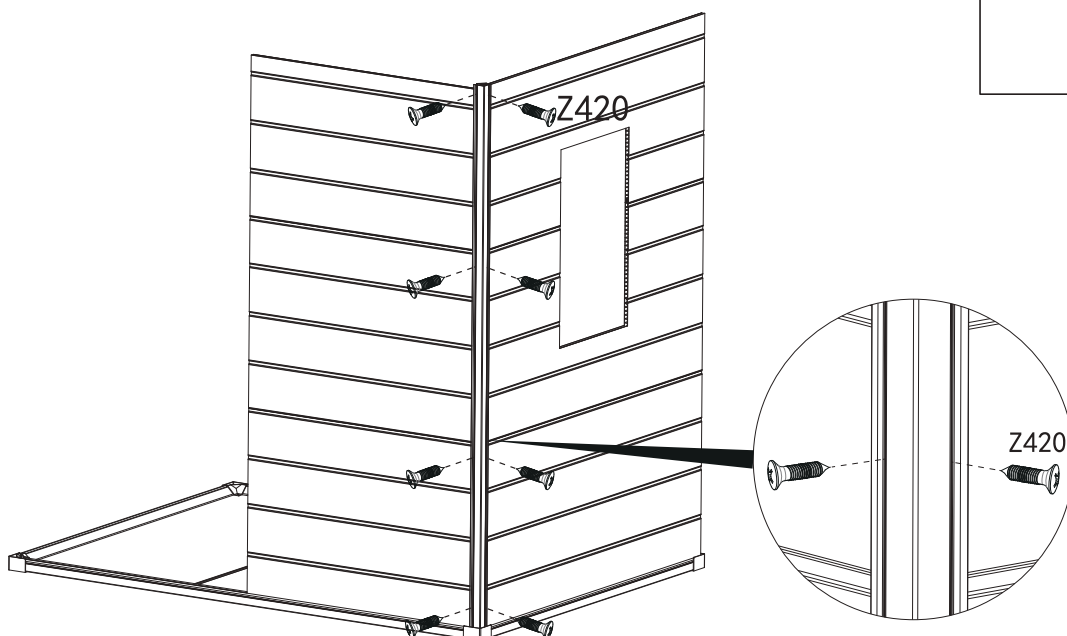
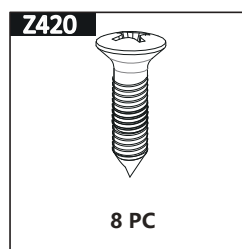

Step 16

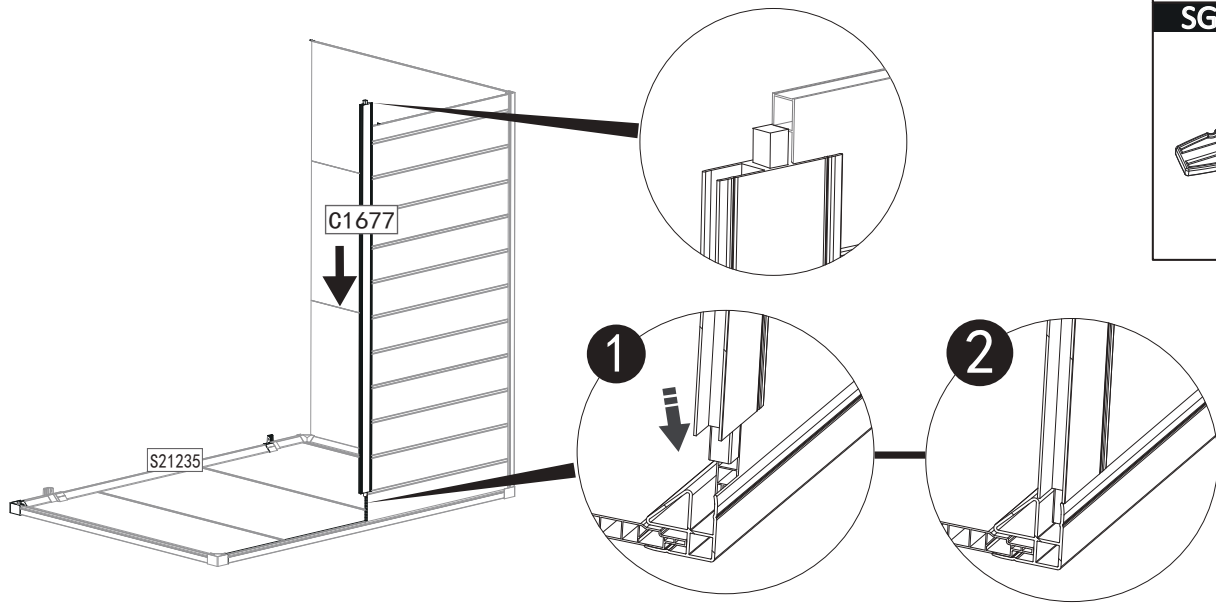

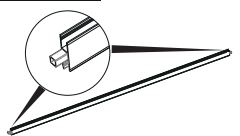
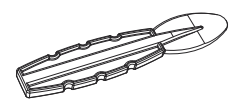
C1677  1 PC
SG8 

Step 17

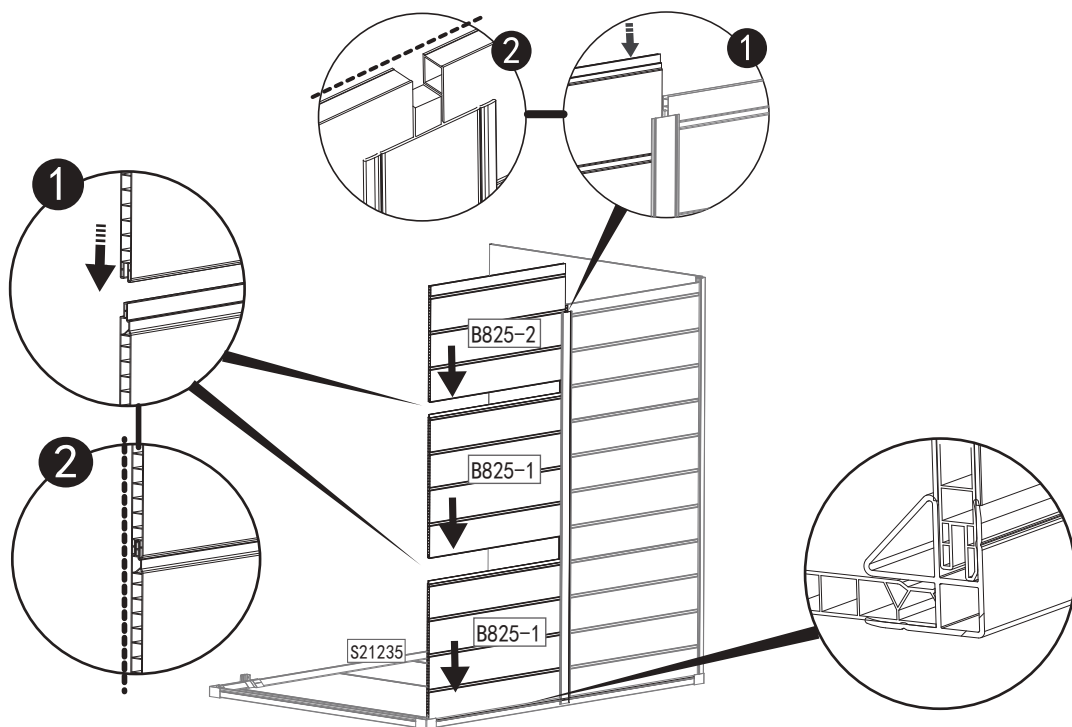
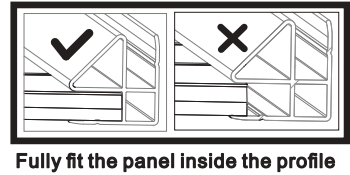

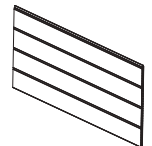
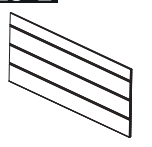
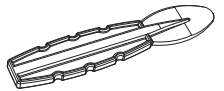

B825-1  2 PC
B825-2  1 PC
SG8 

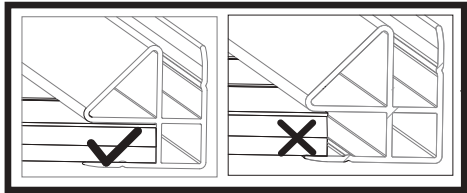
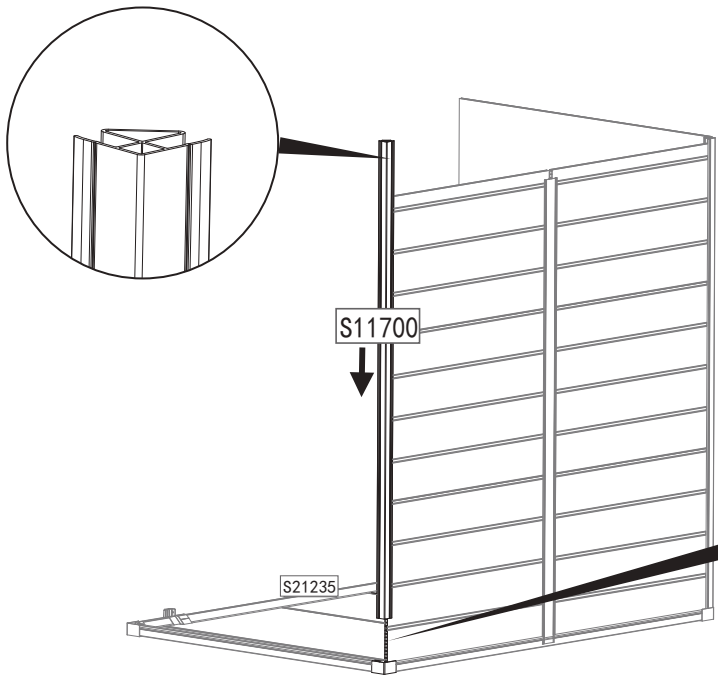
Step 18

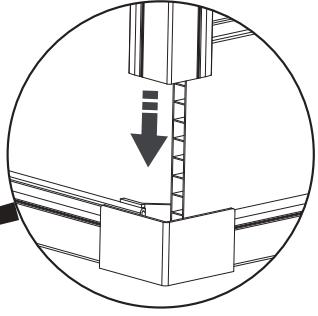

● Fully fit the panel inside the profile

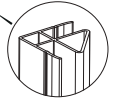
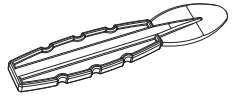

S11700  1 PC	
SG8 	

Step 19

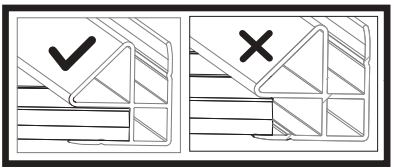

Fully fit the panel inside the profile

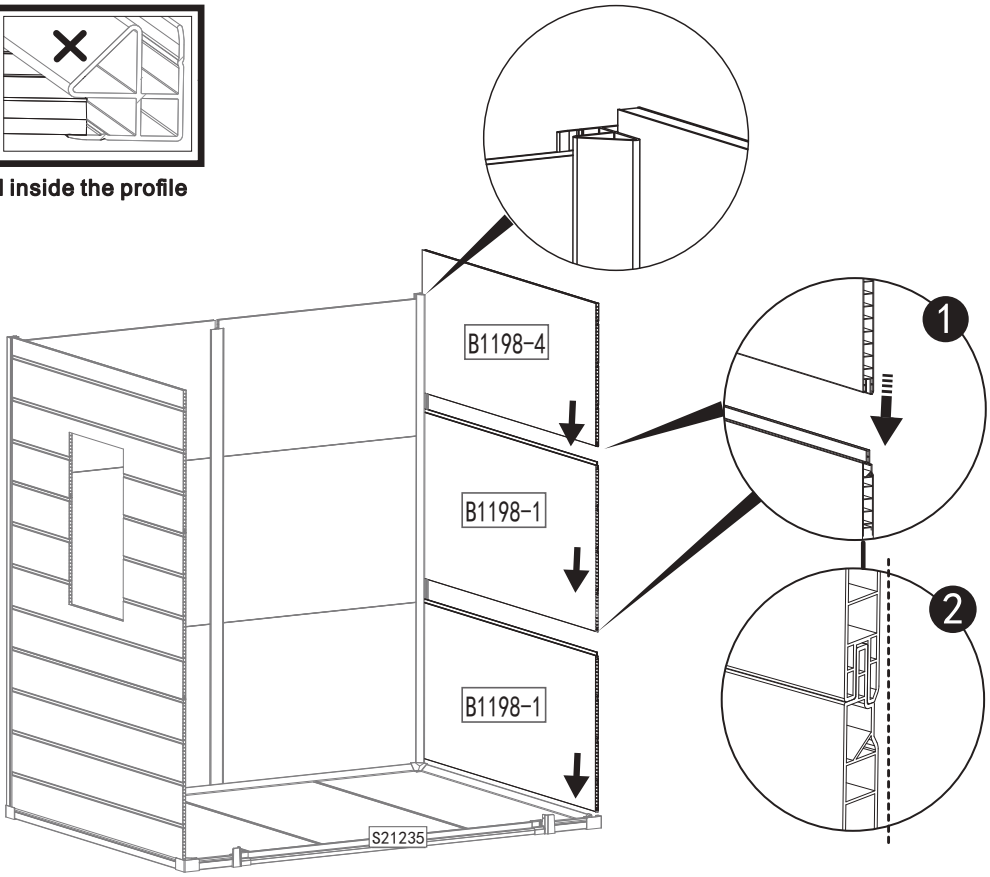

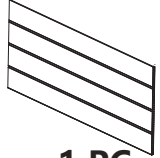
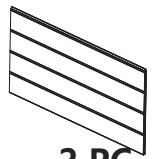
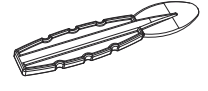
B1198-4  1 PC	
B1198-1  2 PC	
SG8 	

Step 20

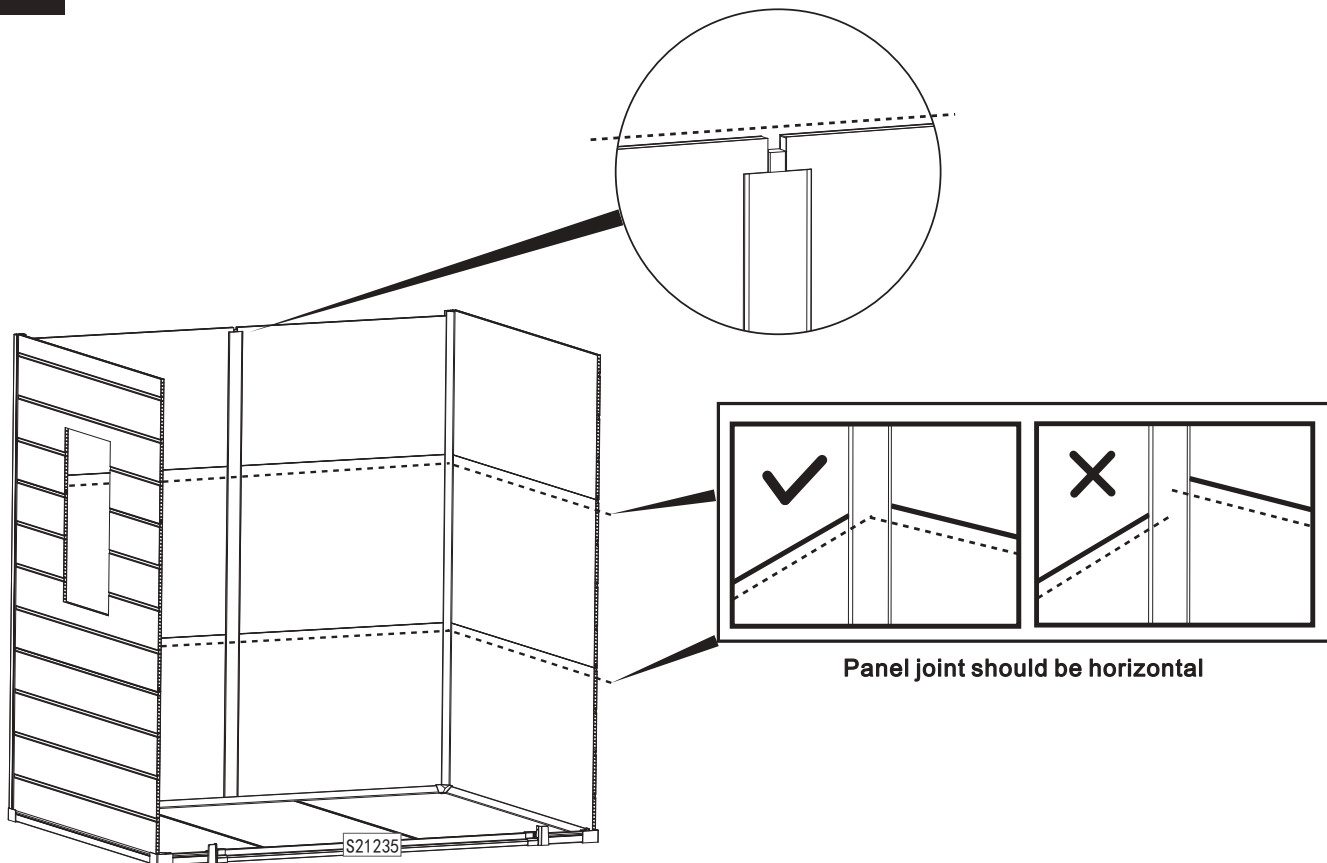

Step 21

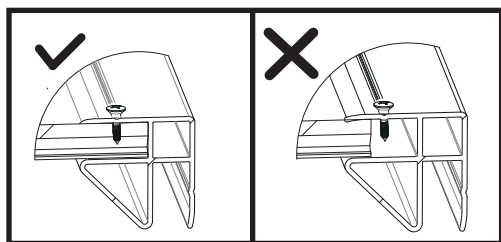

Screw along the marked lines in profile

Z420



8 PC

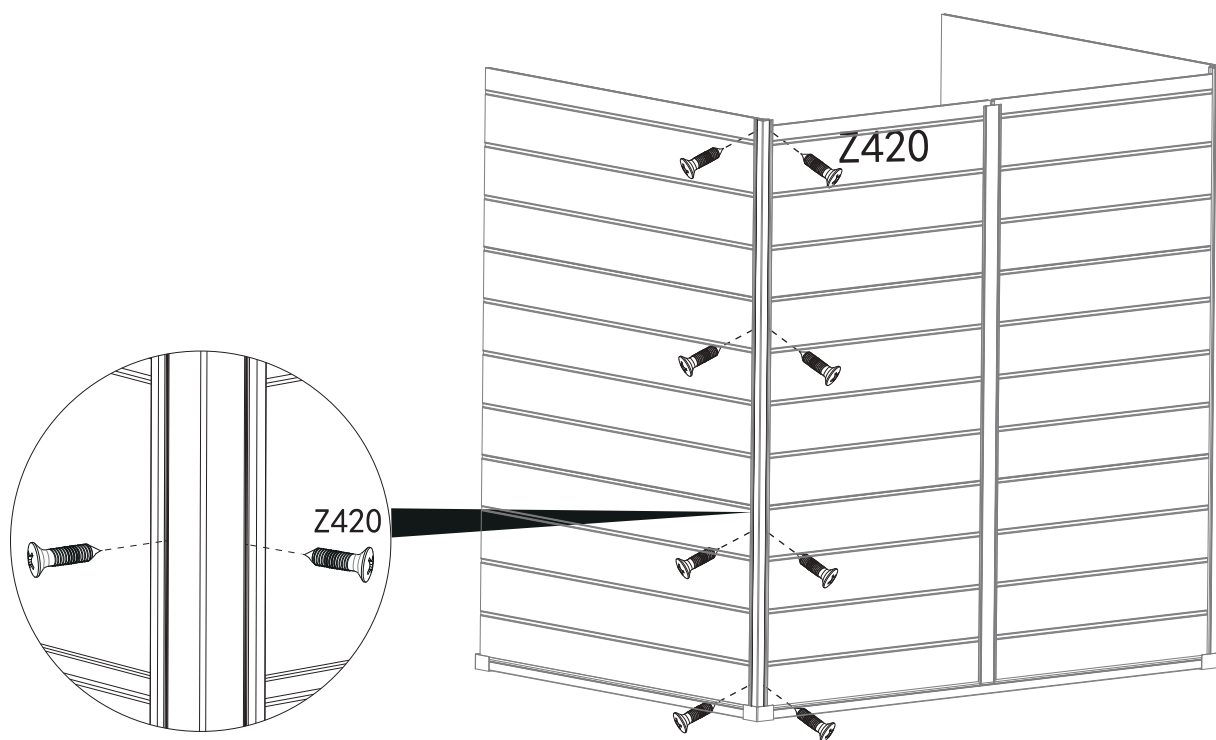

Step 22

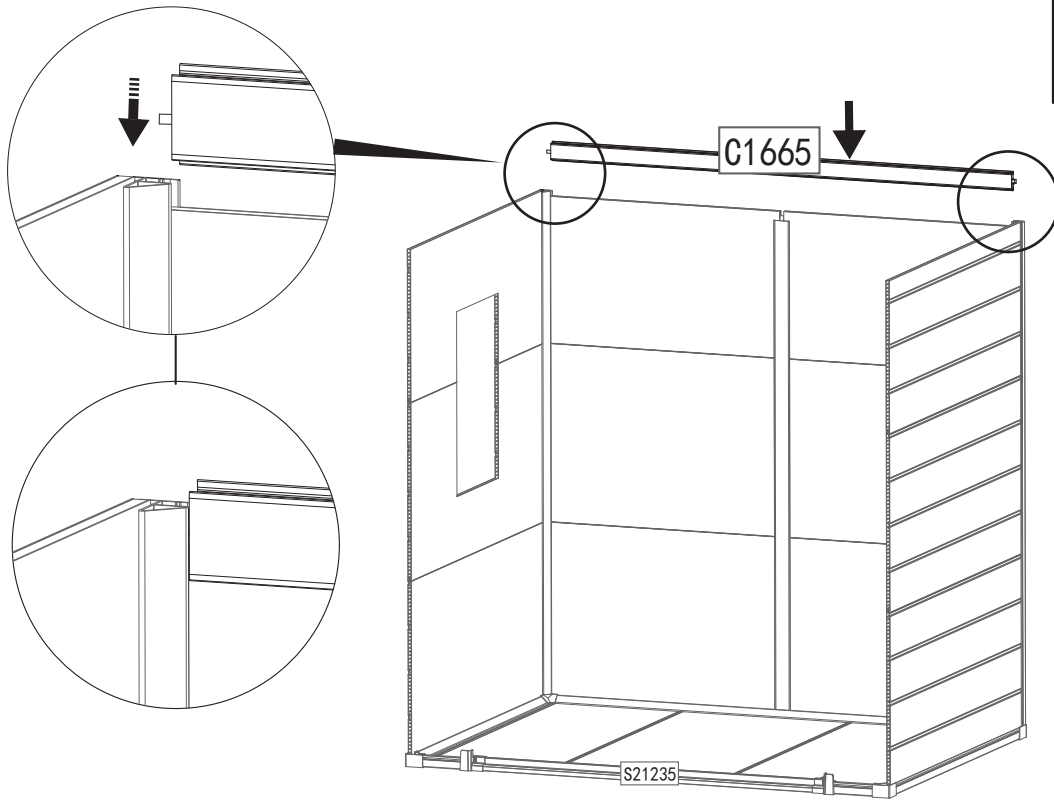

C1665

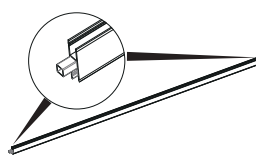

1 PC

Step 23

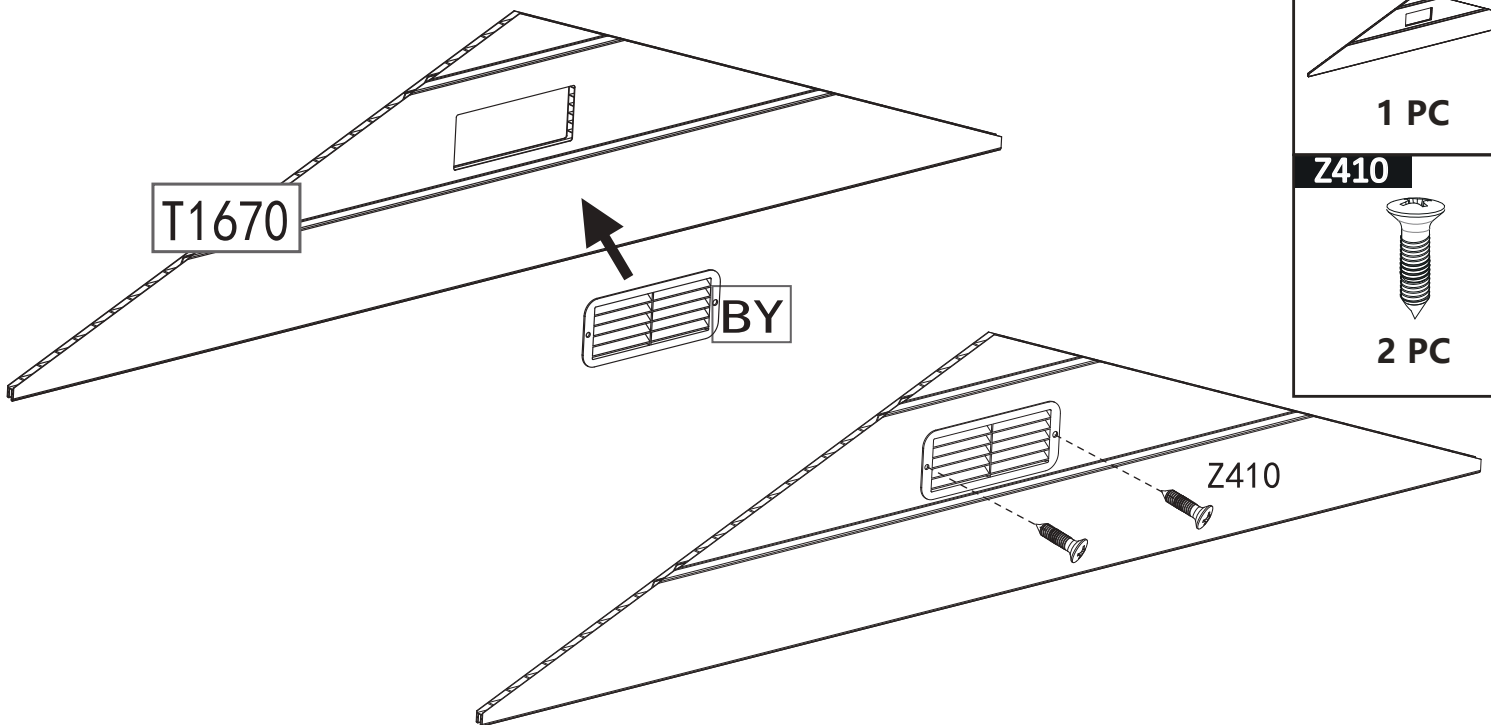

BY

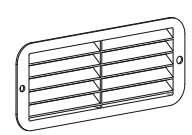

1 PC

T1670

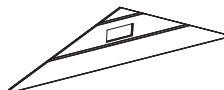

1 PC

Z410

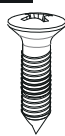

2 PC

Step 24

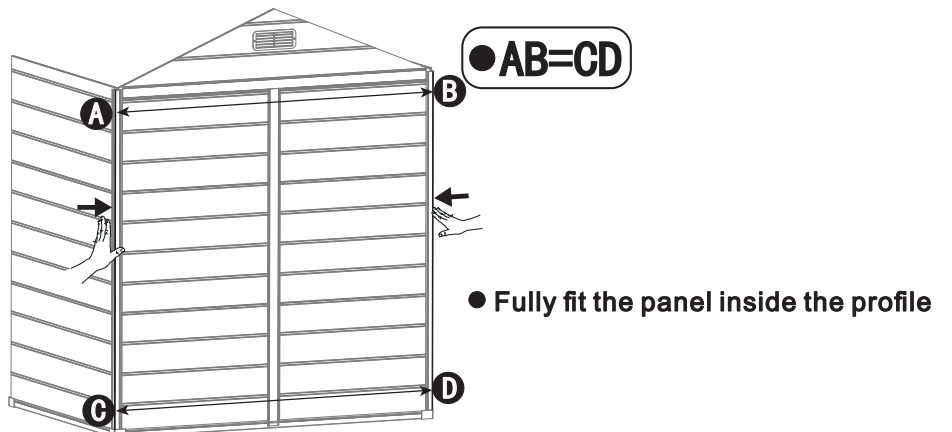
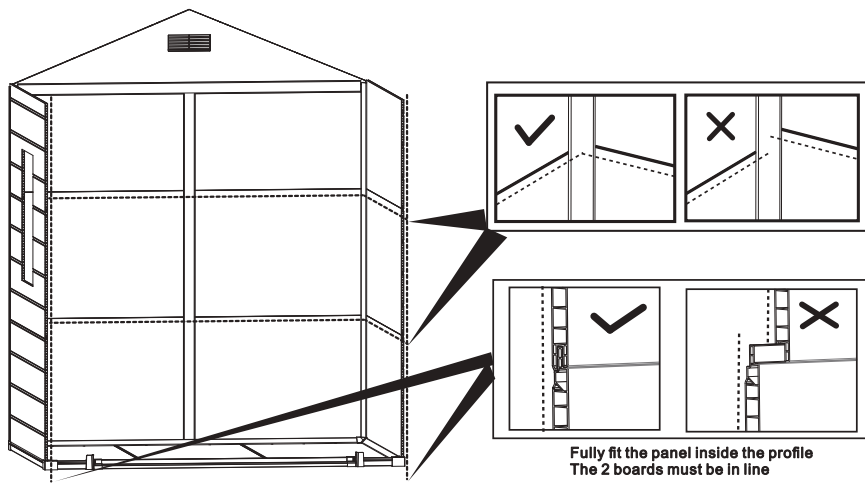
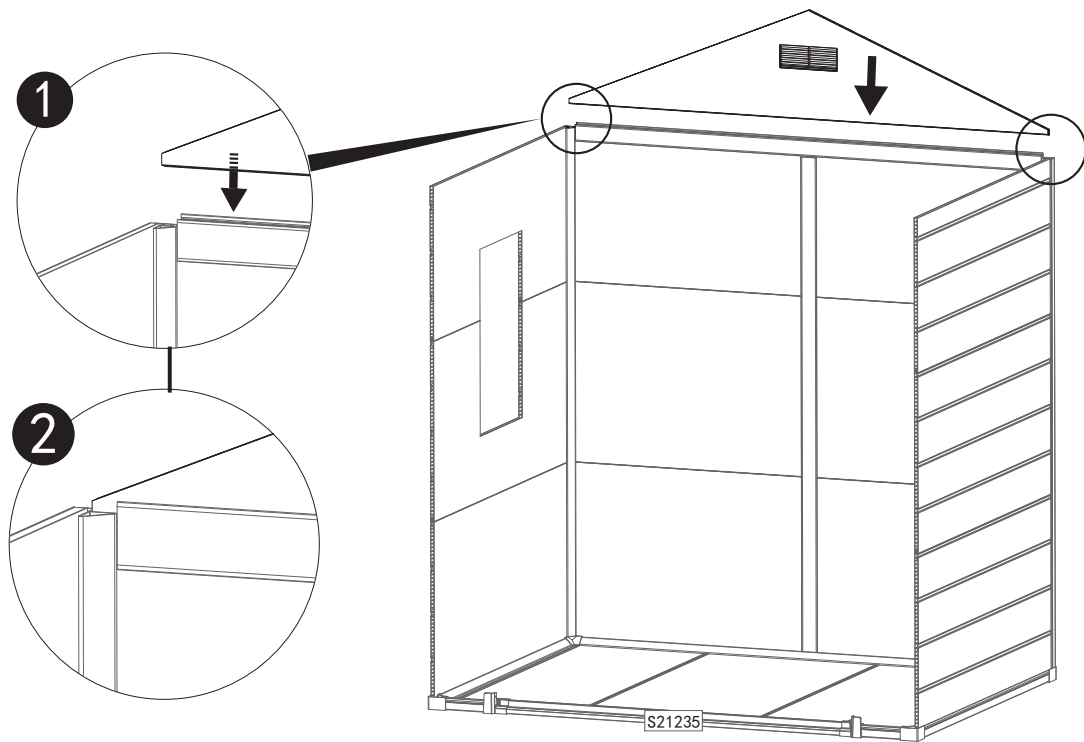

Step 25

Z410

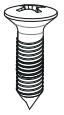

16 PC

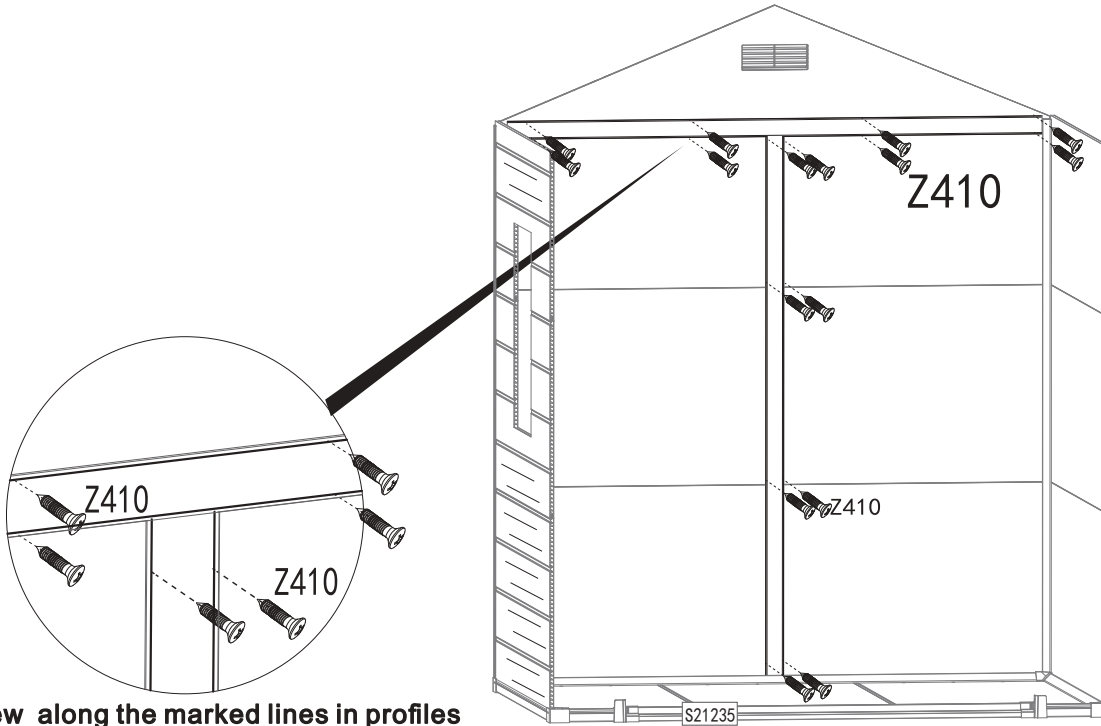
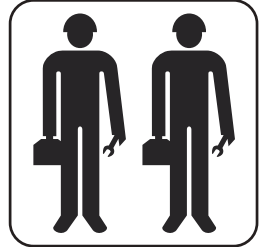

Screw along the marked lines in profiles

Step 26

S11700

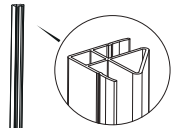

2 PC

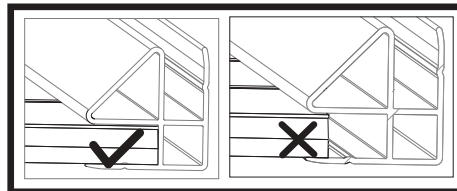

● Fully fit the panel inside the profile

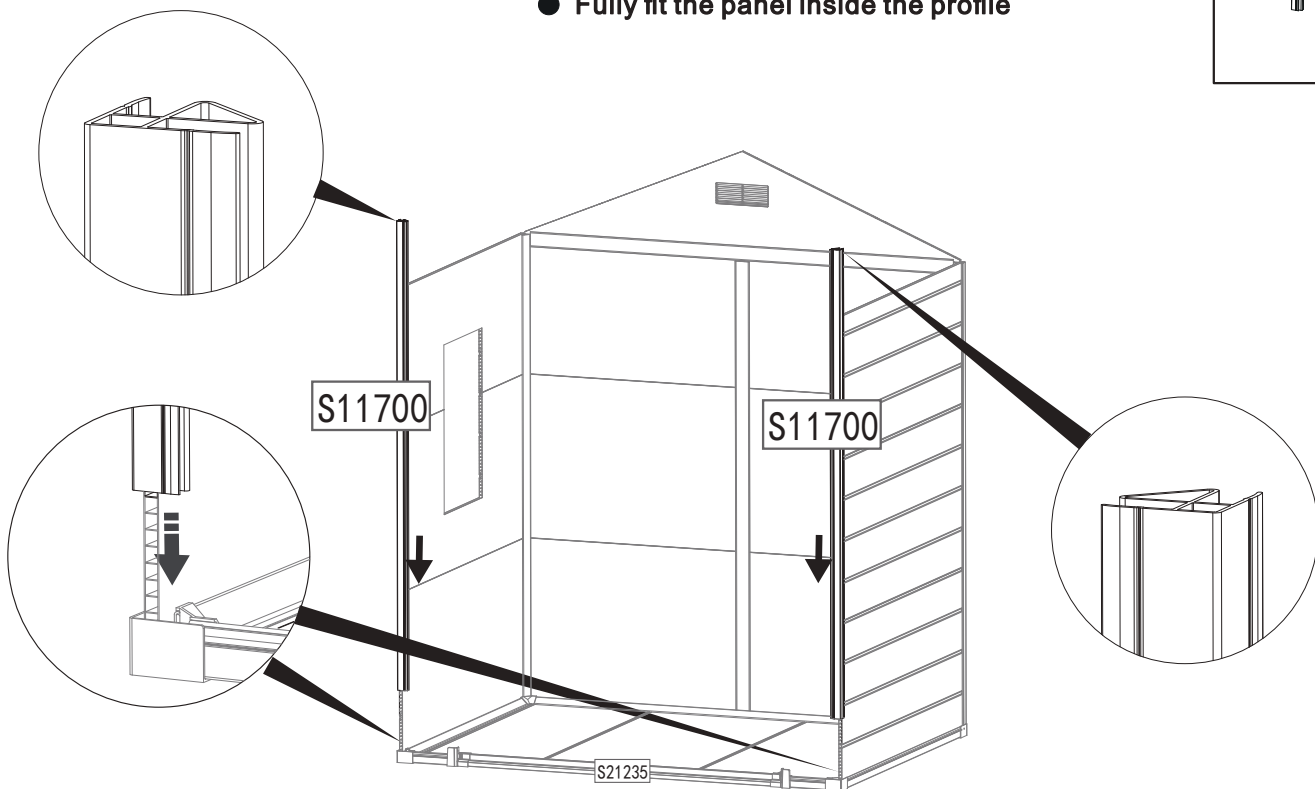

Step 27

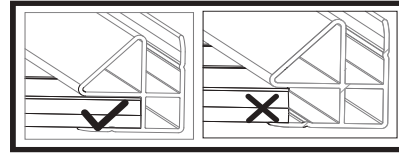

● Fully fit the panel inside the profile

B207-1



4 PC

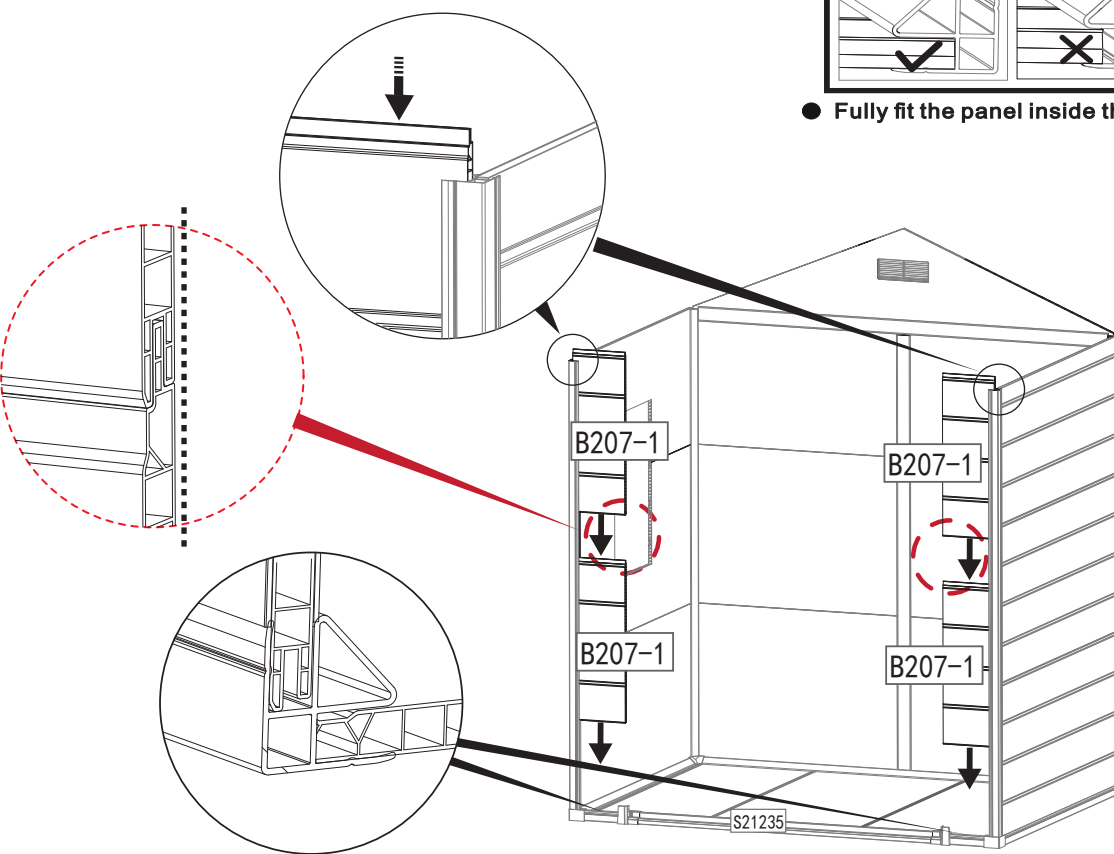
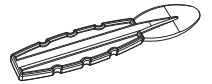

Step 28

B207-2

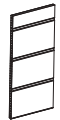

2 PC

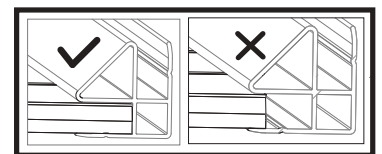
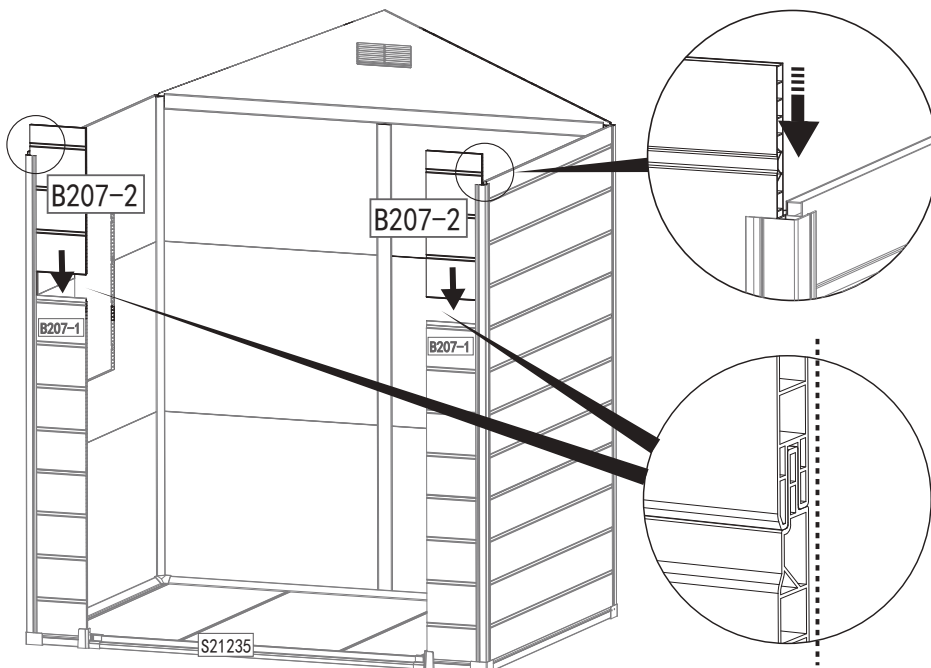

Fully fit the panel inside the profile

Step 29

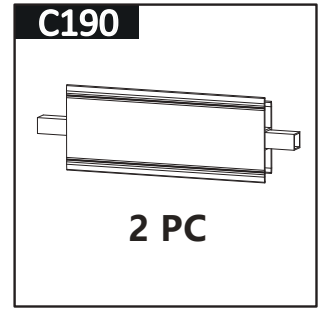
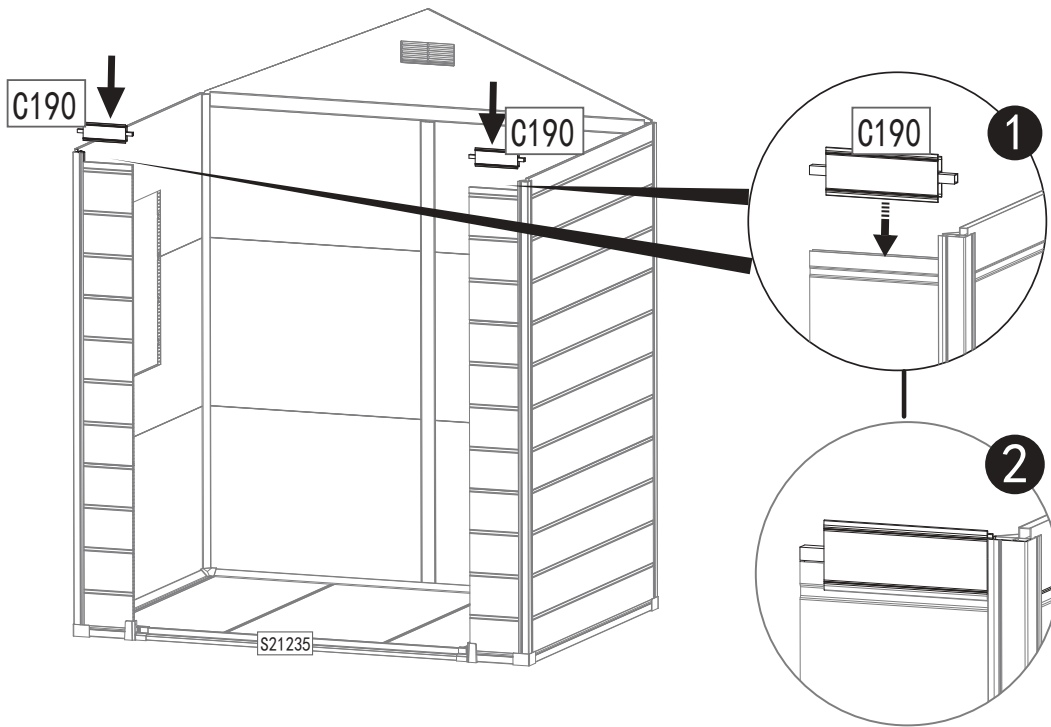

Step 30

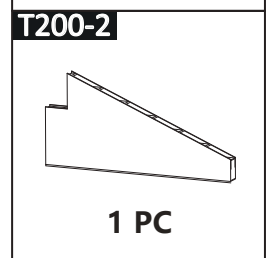
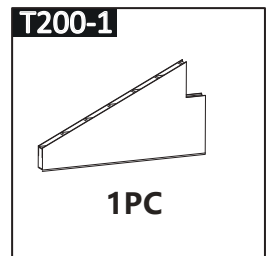
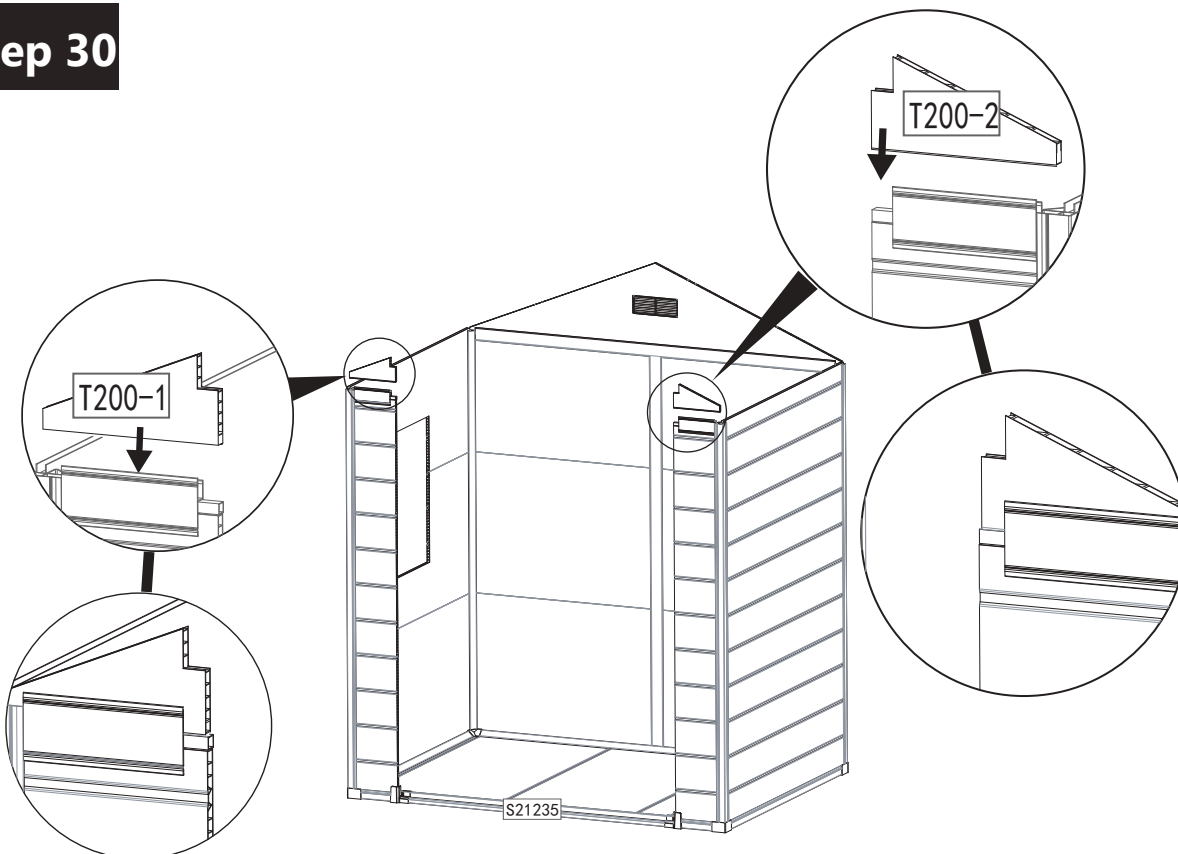

Step 31

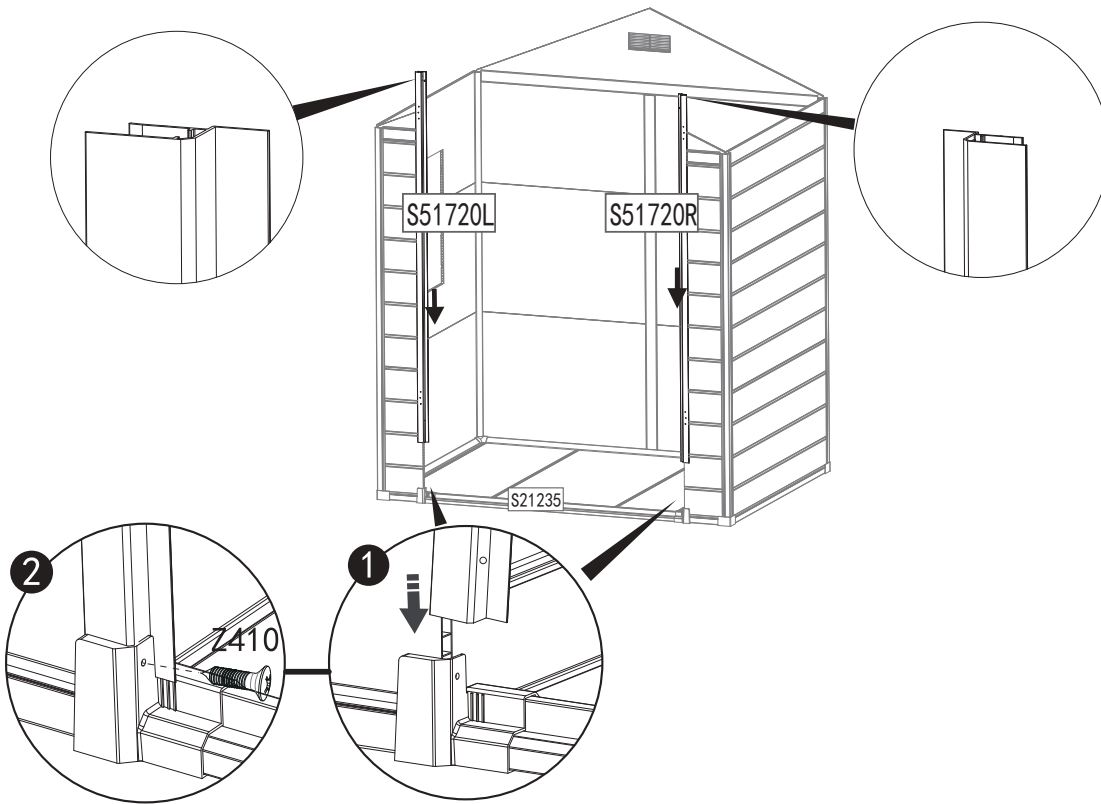

S51720L	
1 PC	
S51720R	
1 PC	
Z410	
2 PC	

Step 32

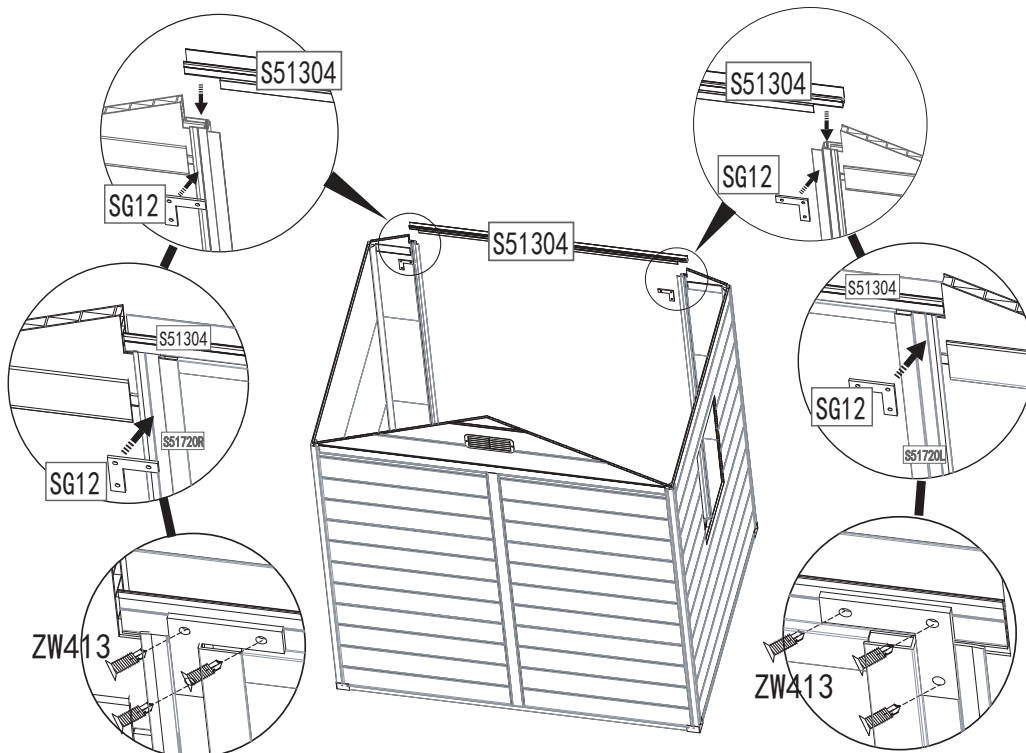

S51304	
1 PC	
ZW413	
6 PC	
SG12	
2 PC	

Step 33

AB=CD

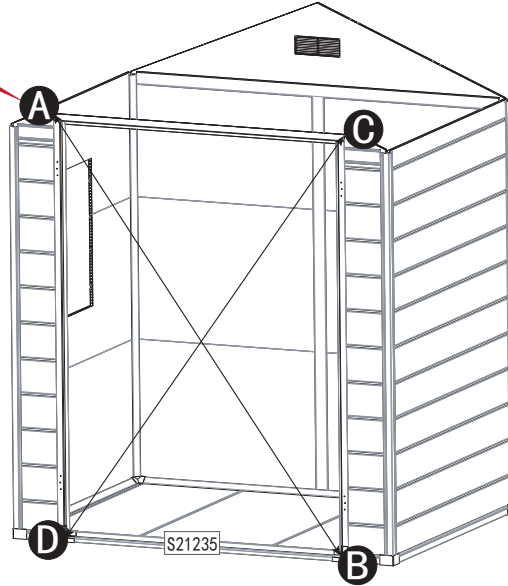

Z420

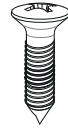

16 PC

Screw when the boards are in position

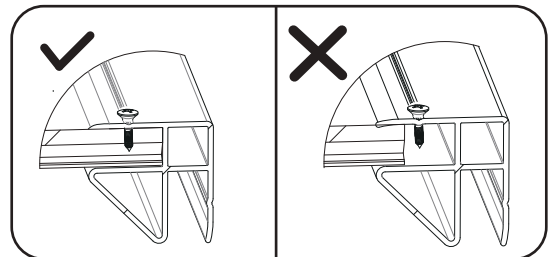
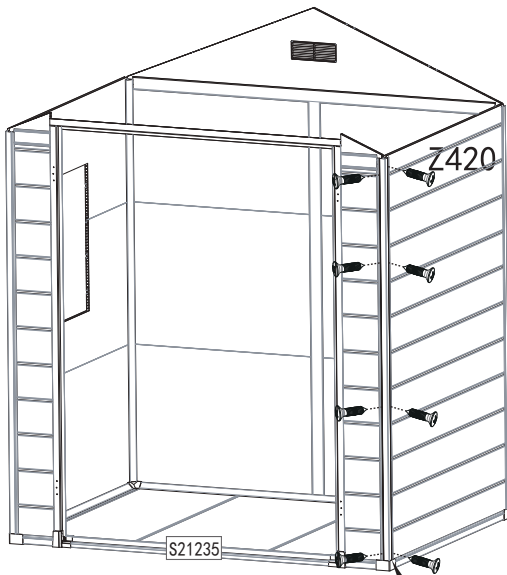

Fully fit the panel inside the profile
Screw along the marked lines in profiles

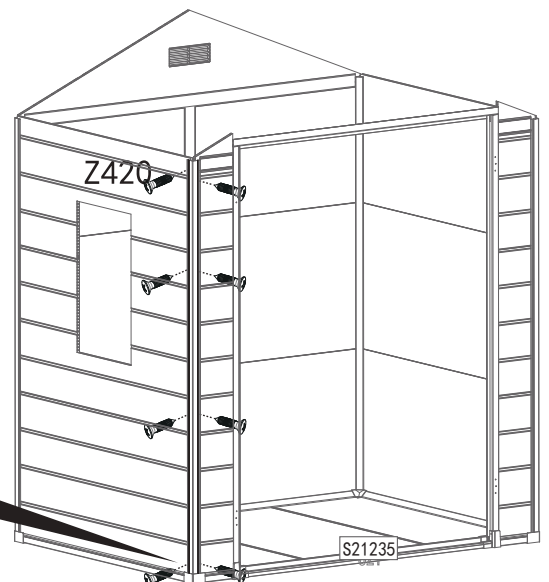
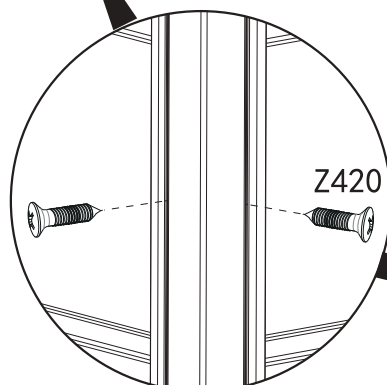

Step 34

Screw when the boards are in position

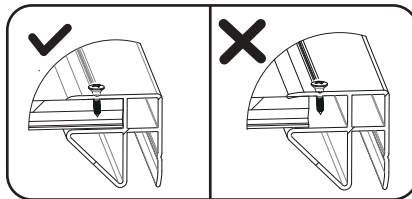
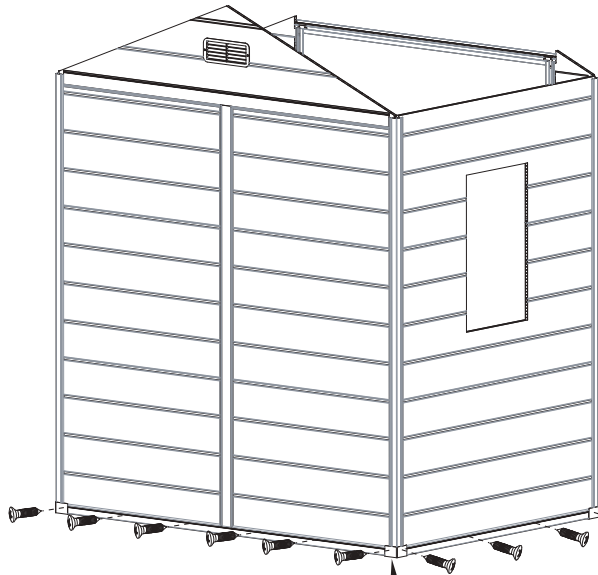

Screw along the marked lines in profiles

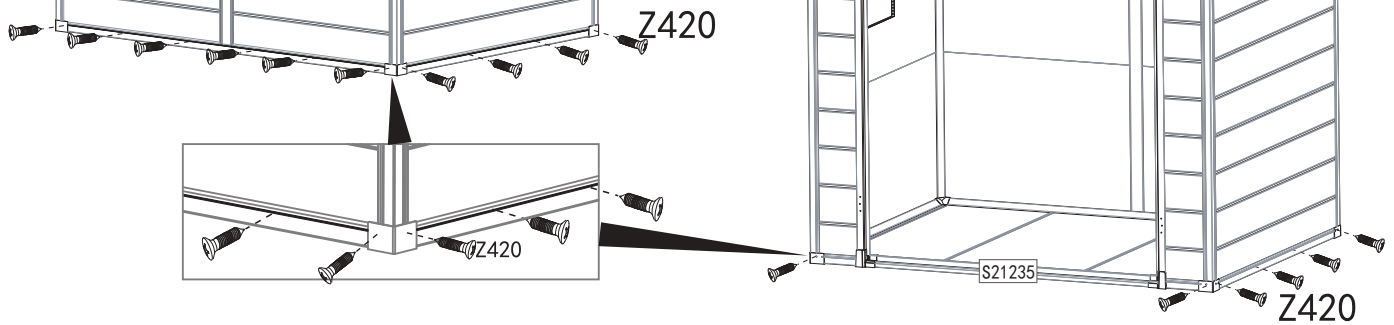
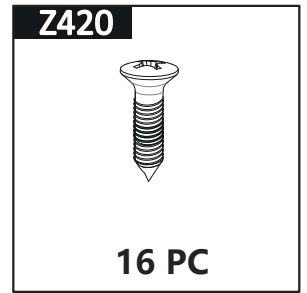

Step 35

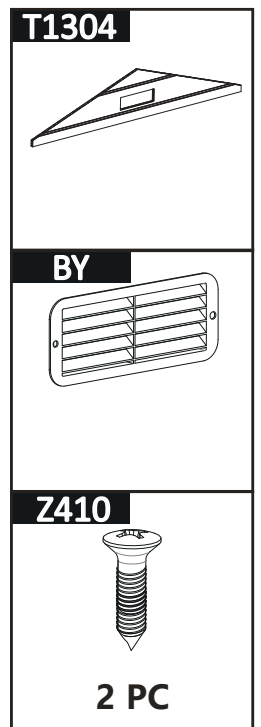
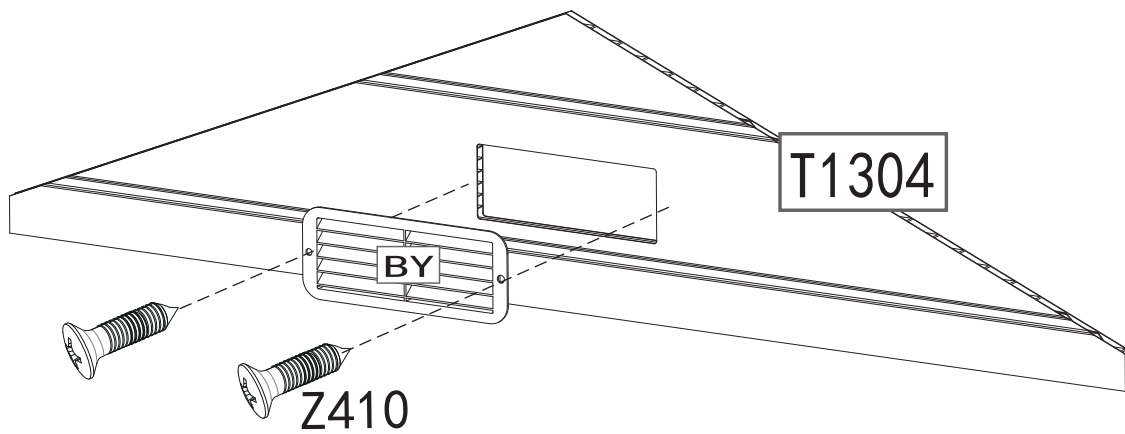

Step 36

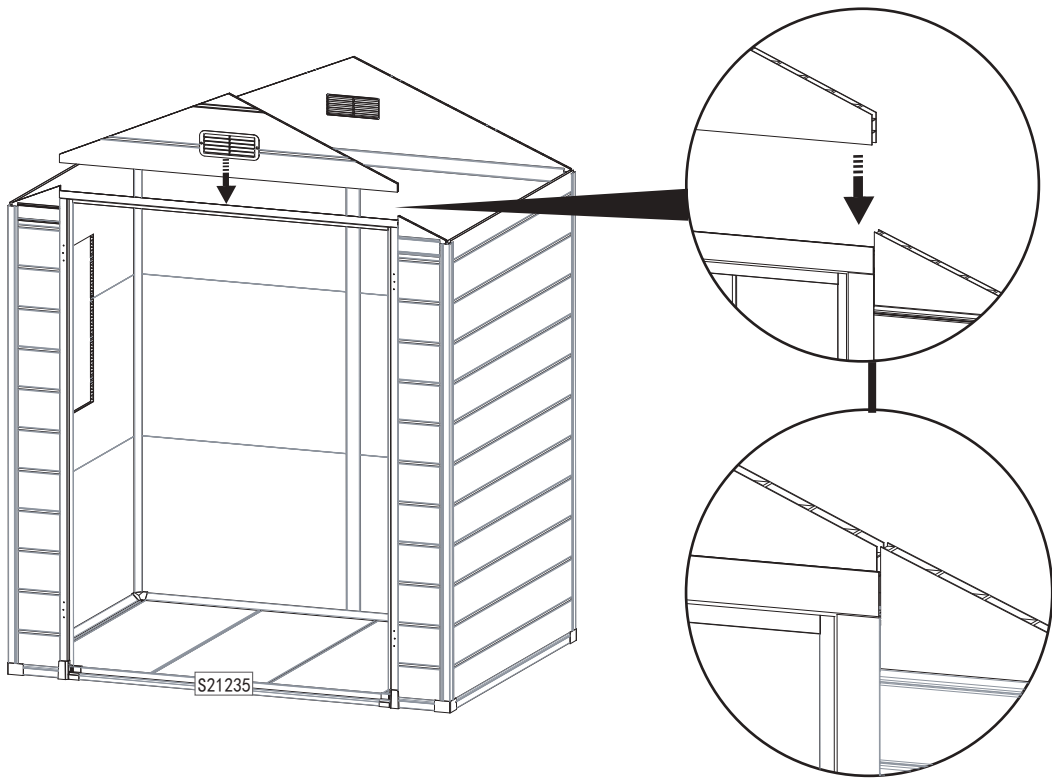

WINDOW PARTS

Step 37

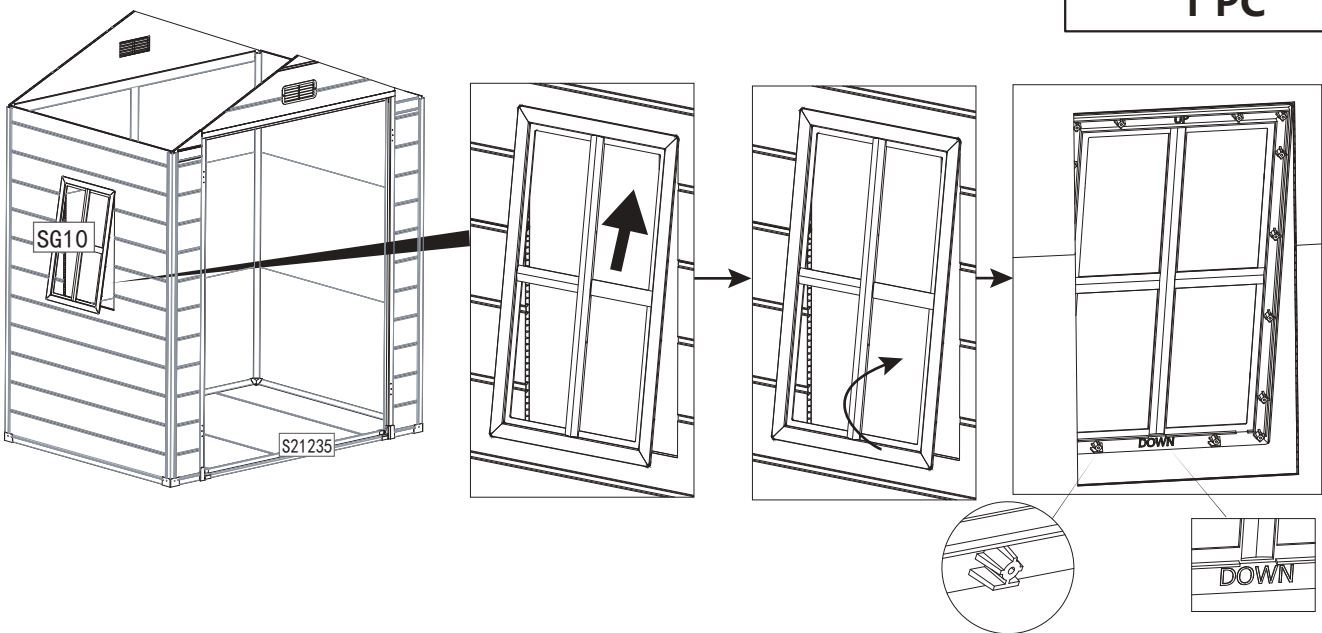
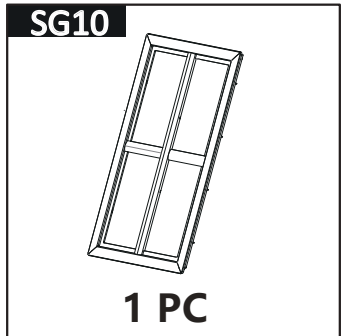

Step 38

- Remove the film before fixing SG101

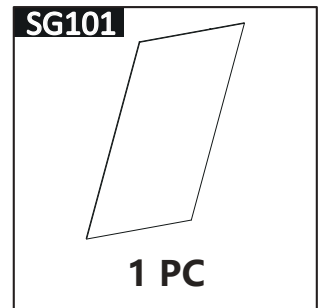
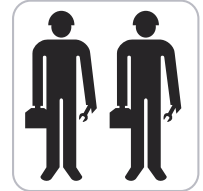
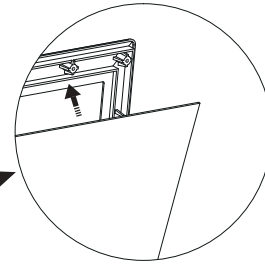
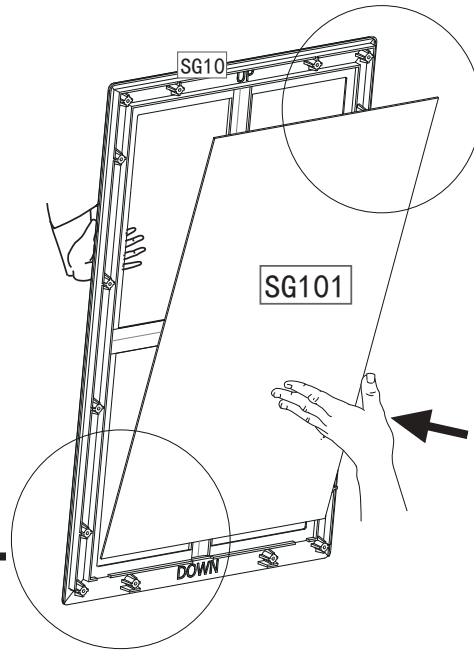
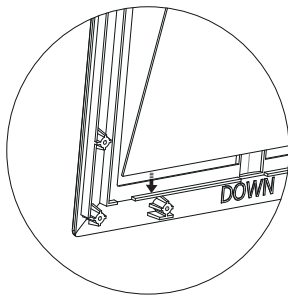
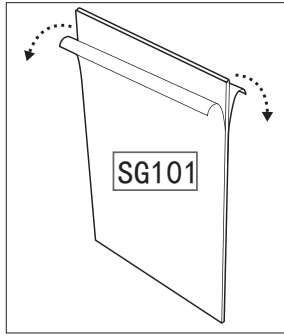

- Need two persons to fix SG101, one person presses it, and the other person assembles it.

Step 39

The press plate boss section shall be pressed against SG101

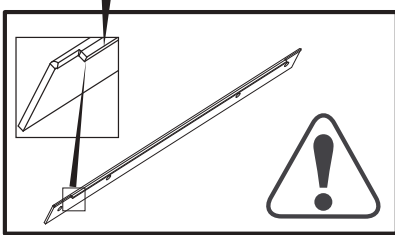

- Press tightly to avoid falling down
- Please note the side with bending edge be pressed to SG101
- It's better to fix just one screw on each SG102&SG103 before each one adjust into right location.

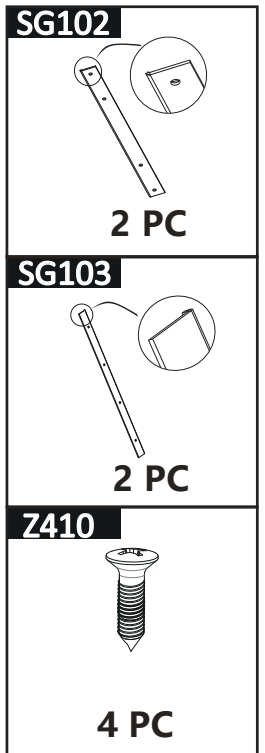
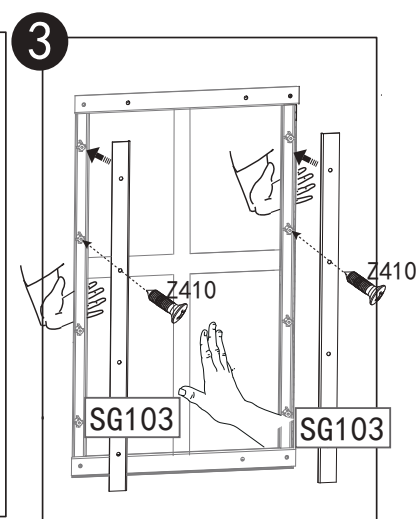
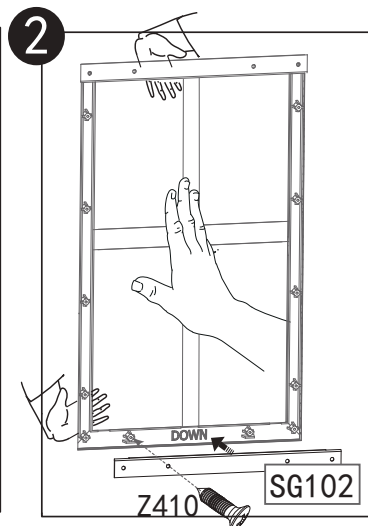
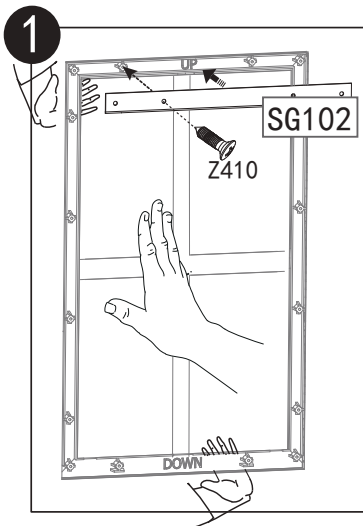

Step 40

Z410

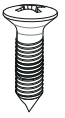

12PC

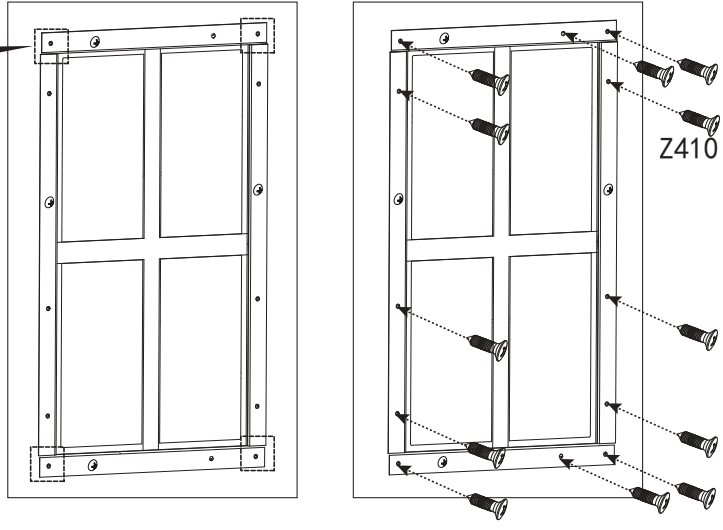
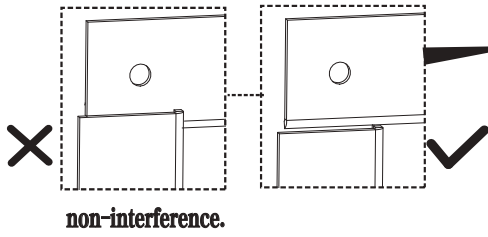

● Adjust SG102&SG103 in right location, then fix all screws

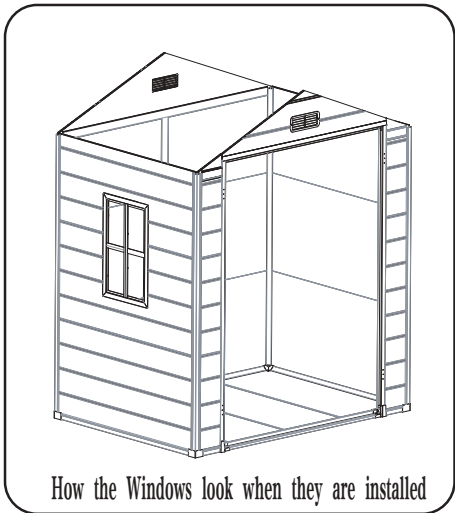

ROOF PARTS

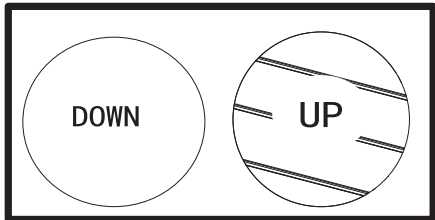
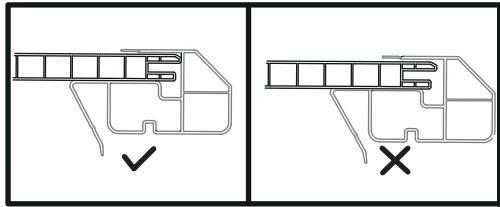

The stripes should be upwards

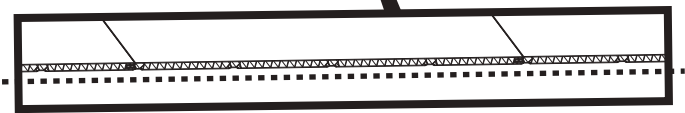
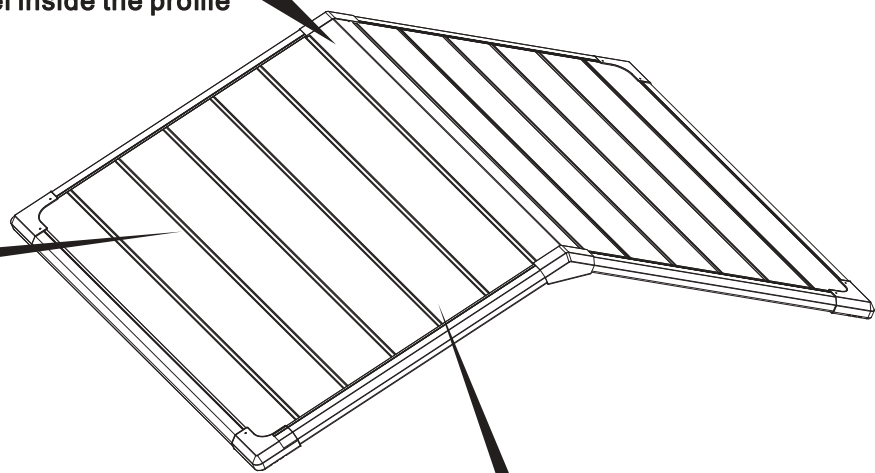

The boards must be straight

Step 41

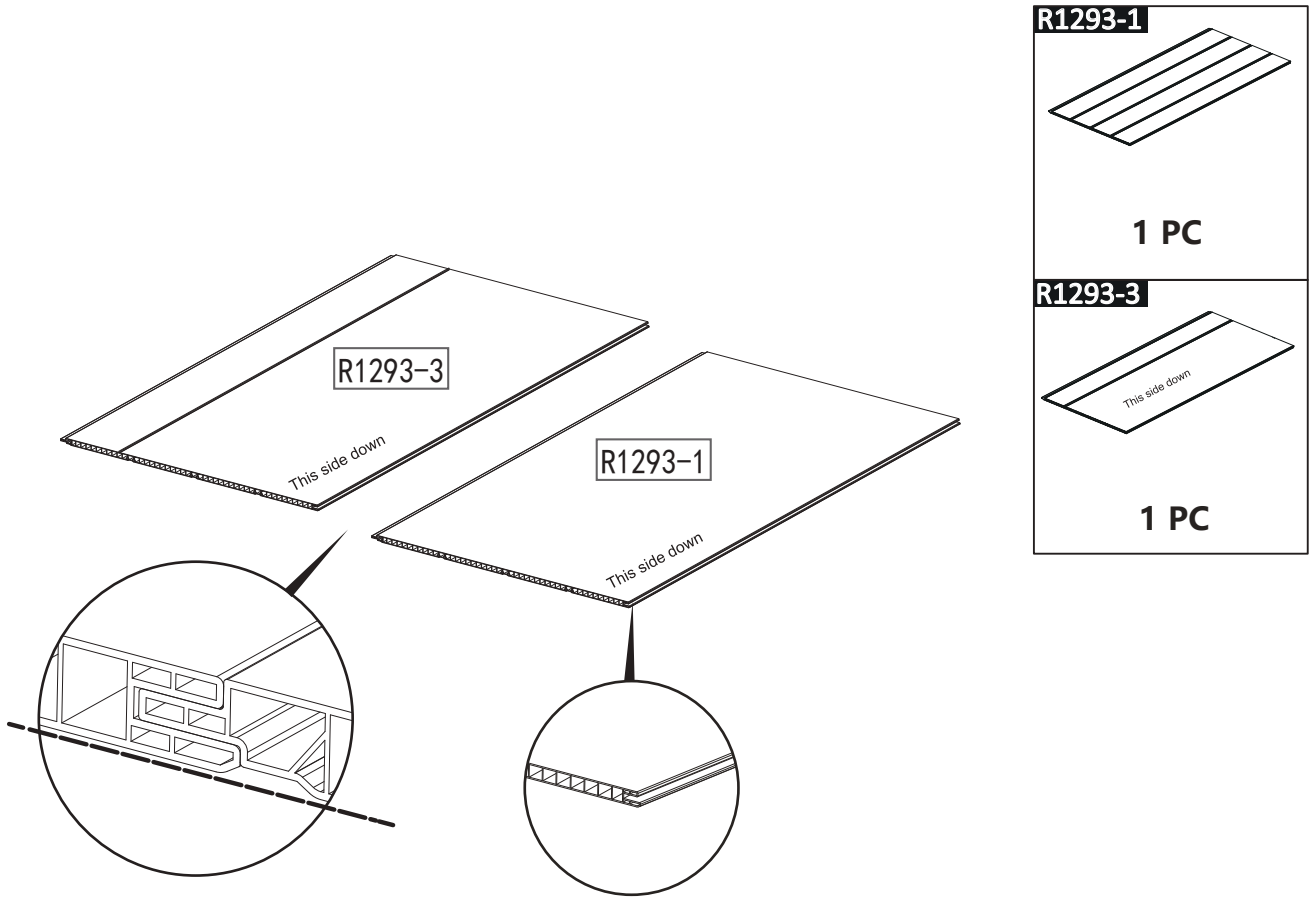

Step 42

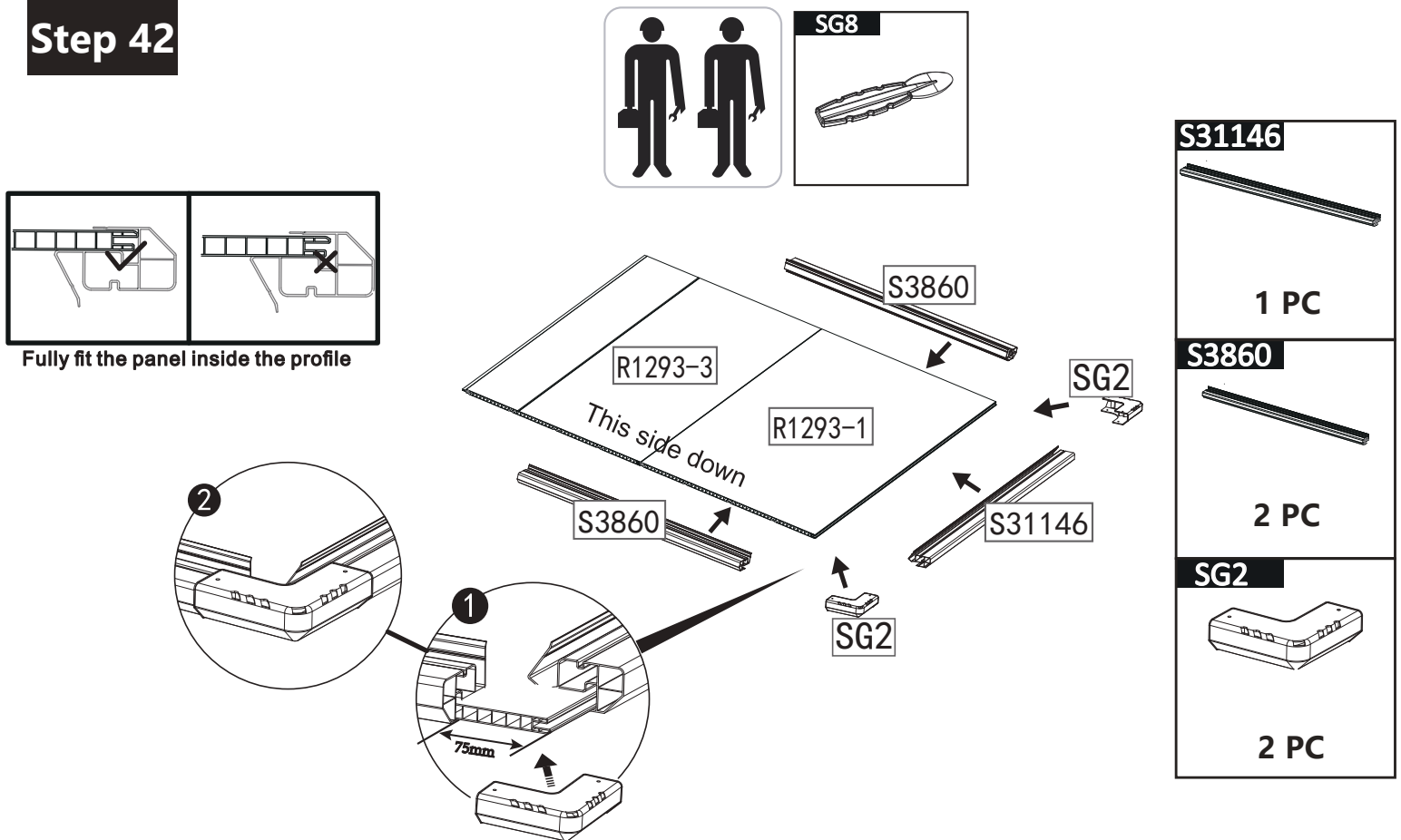

Step 43

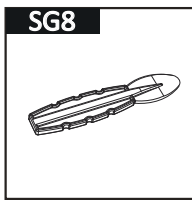

R1293-2	
	1 PC
R1293-1	
	1 PC

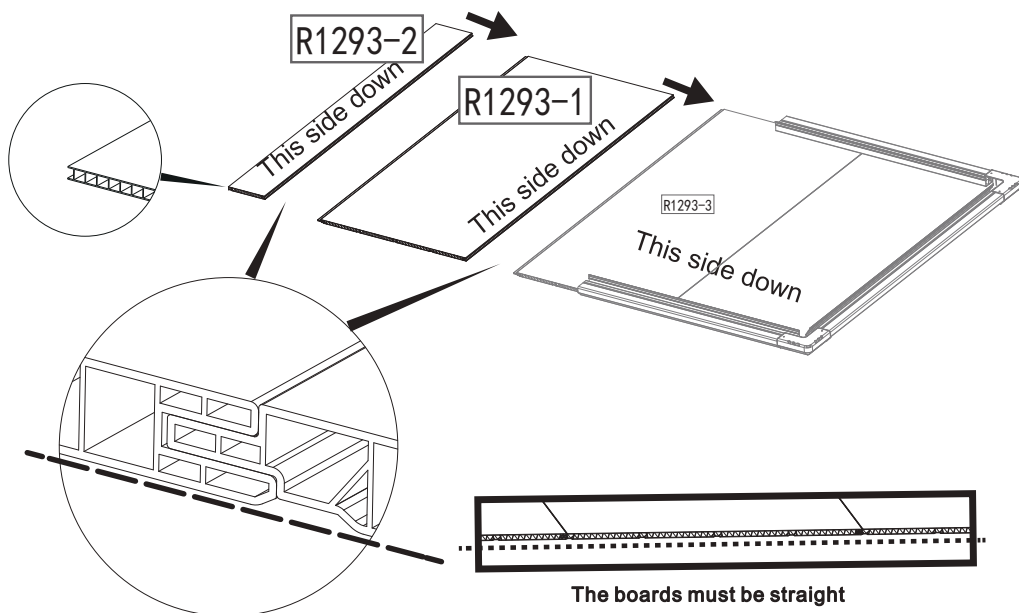

Step 44

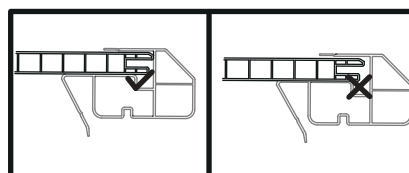
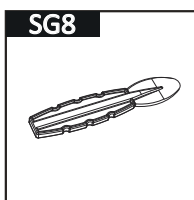

Fully fit the panel inside the profile

S31146	
	1 PC
S3860	
	2 PC
SG2	
	2 PC

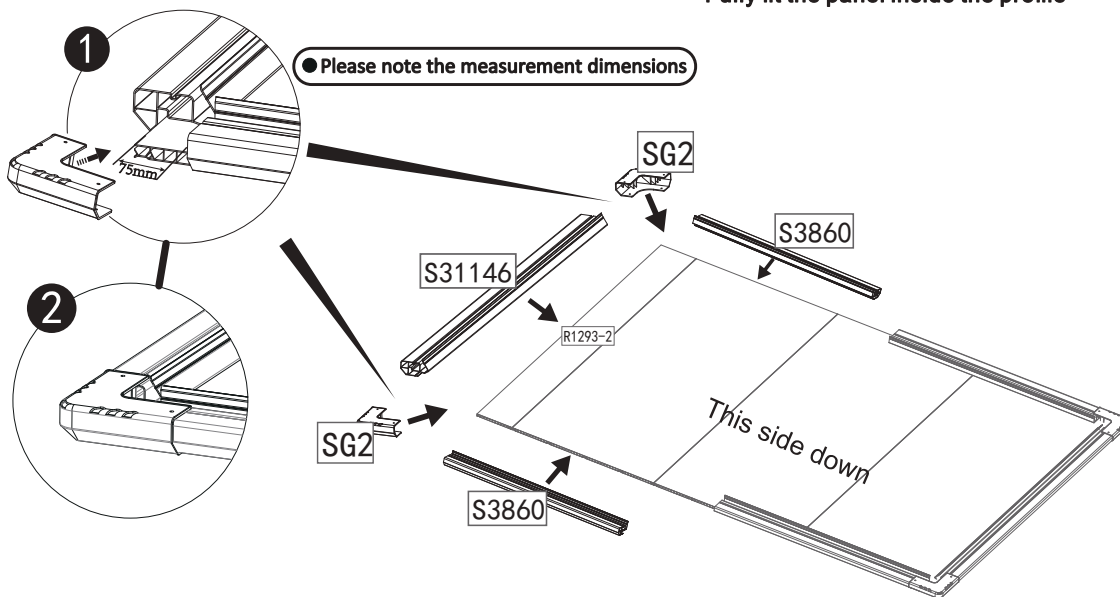

Step 45

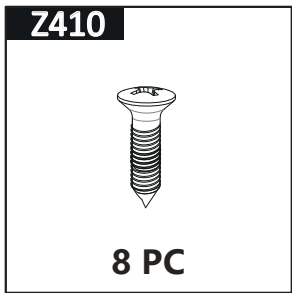

$AB=CD$

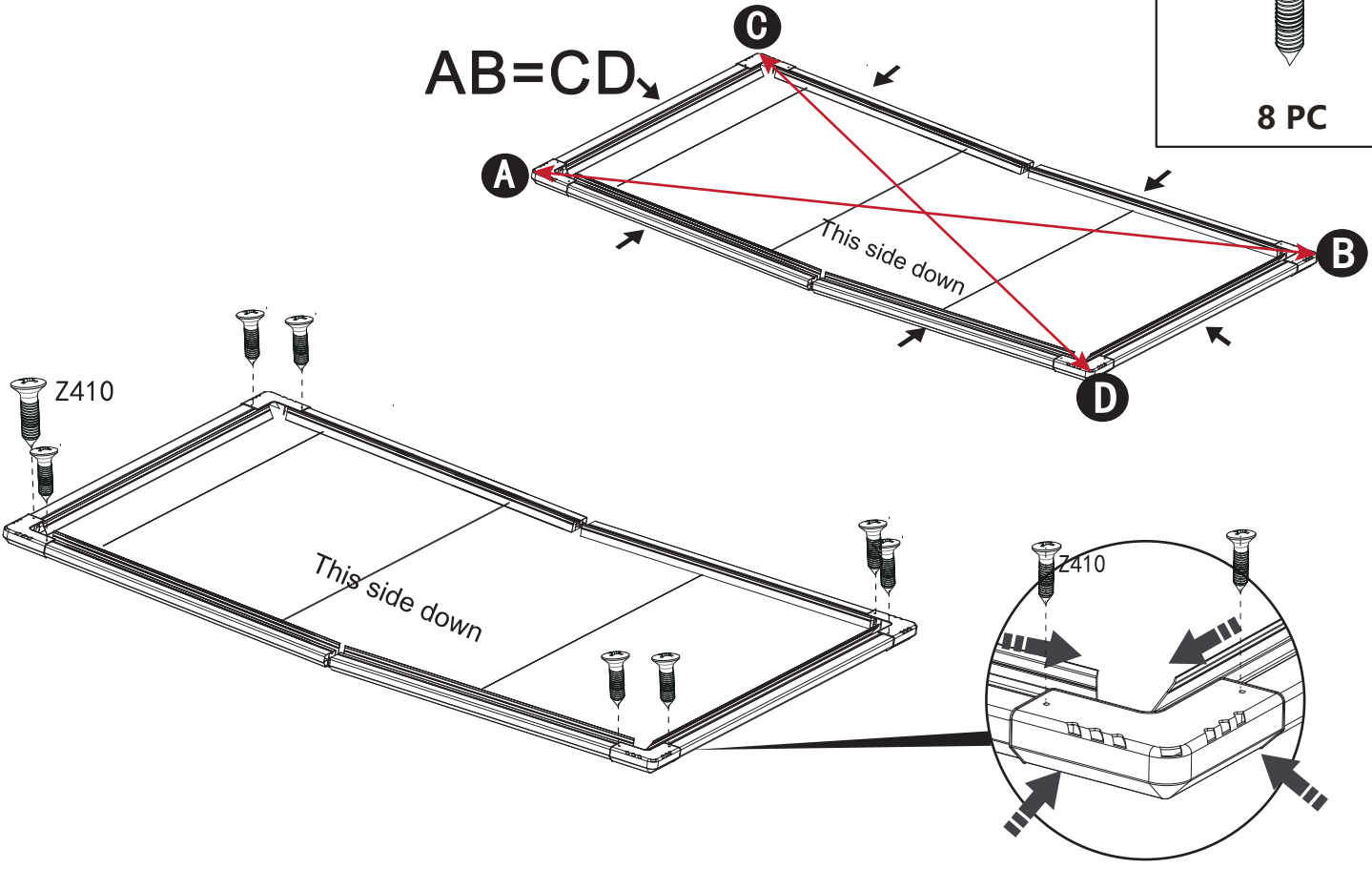

Step 46

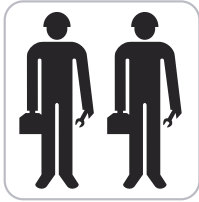

Turn the roof boards over

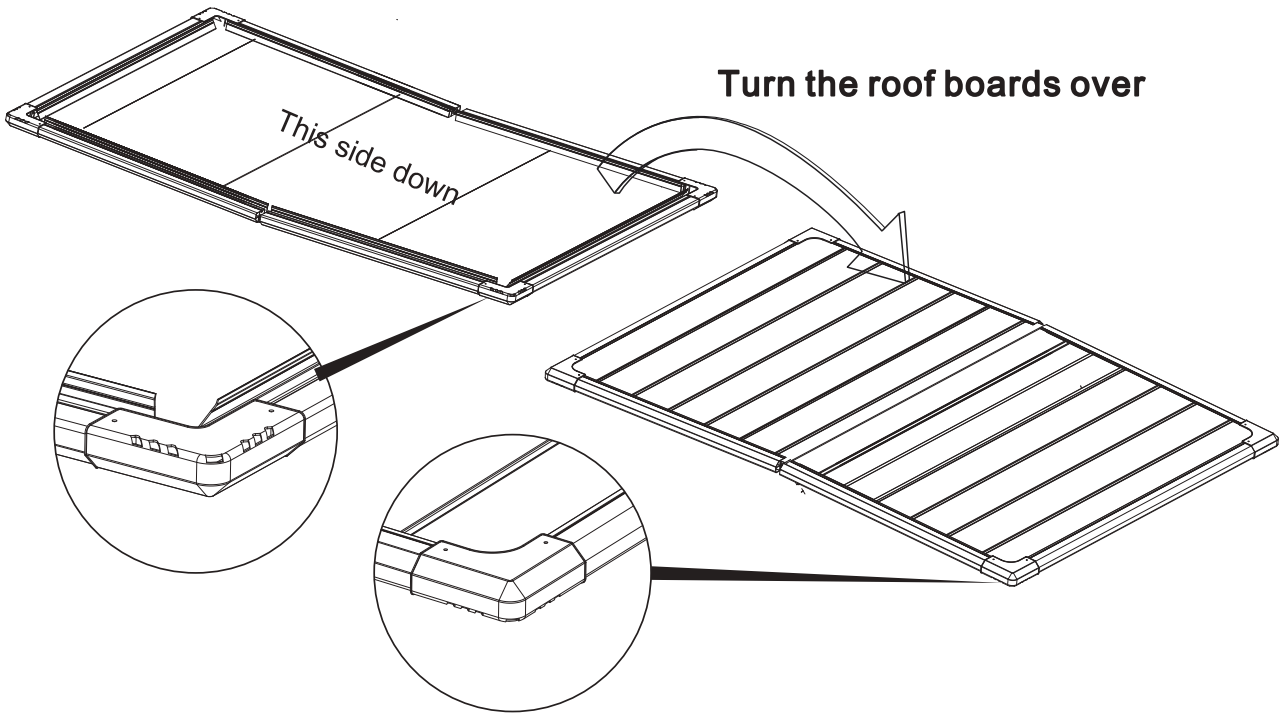

Step 47

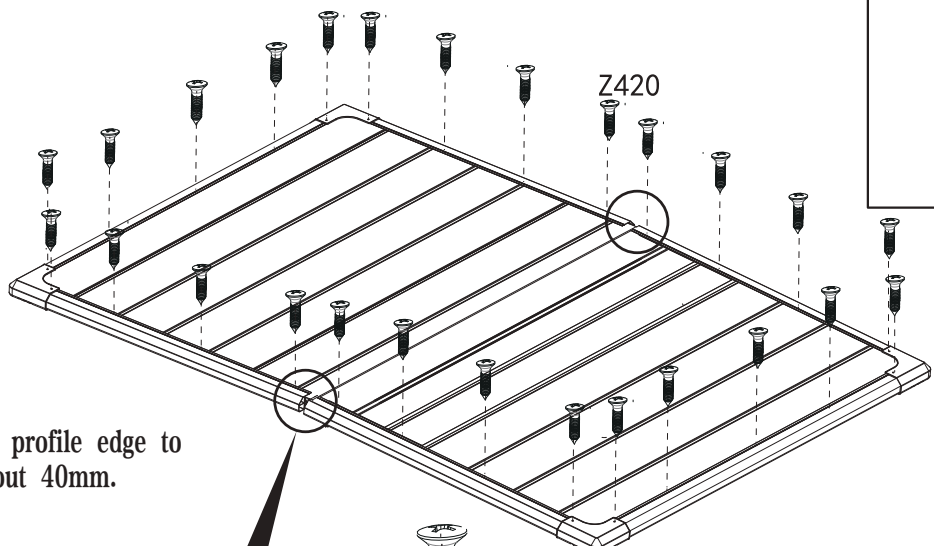
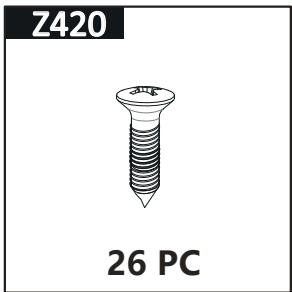

● The distance from the profile edge to the first screw is about 40mm.

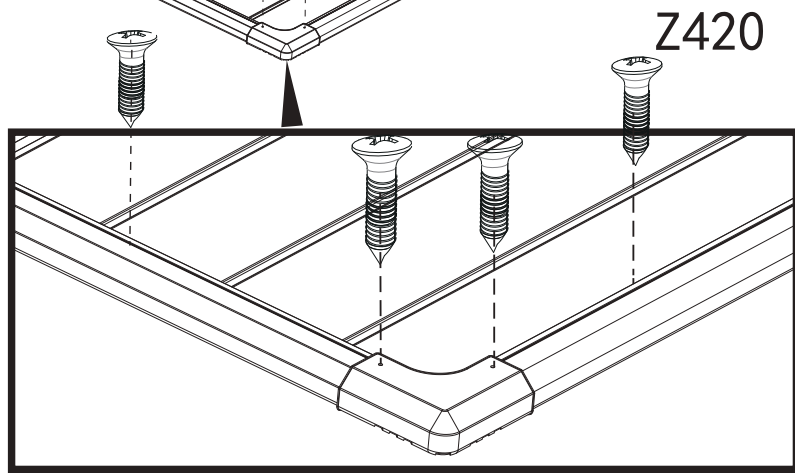
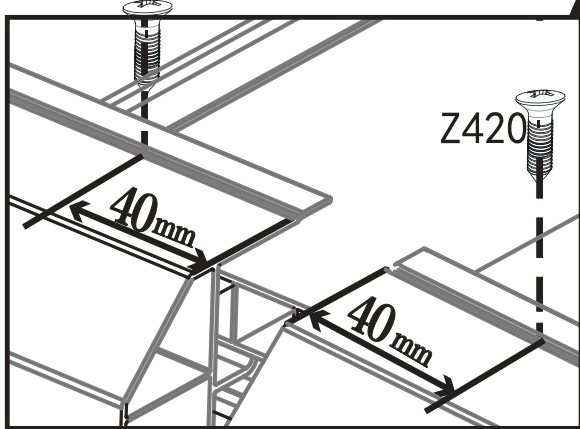

Step 48

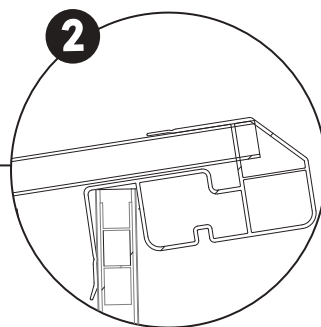
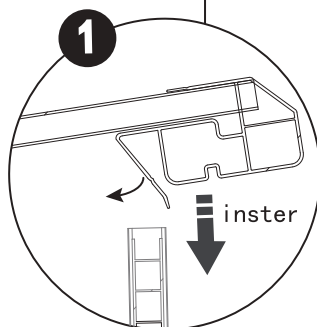
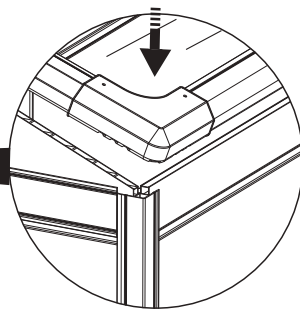
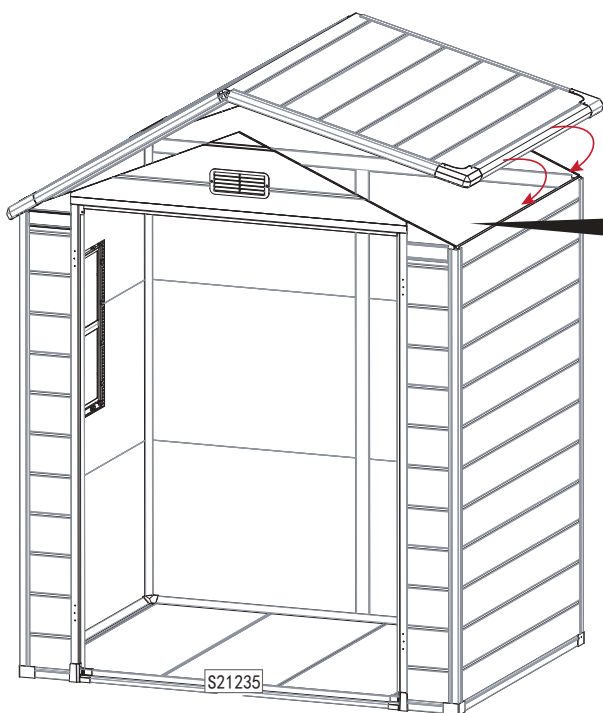

Fully fit the panel inside the profile

Step 49

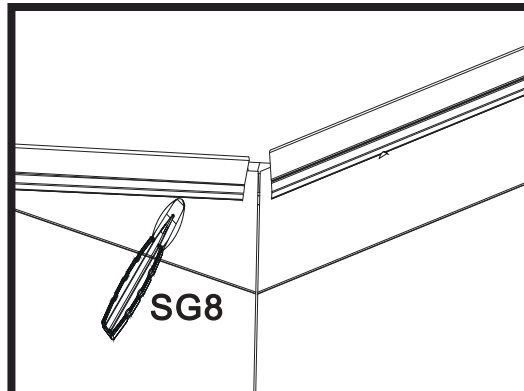
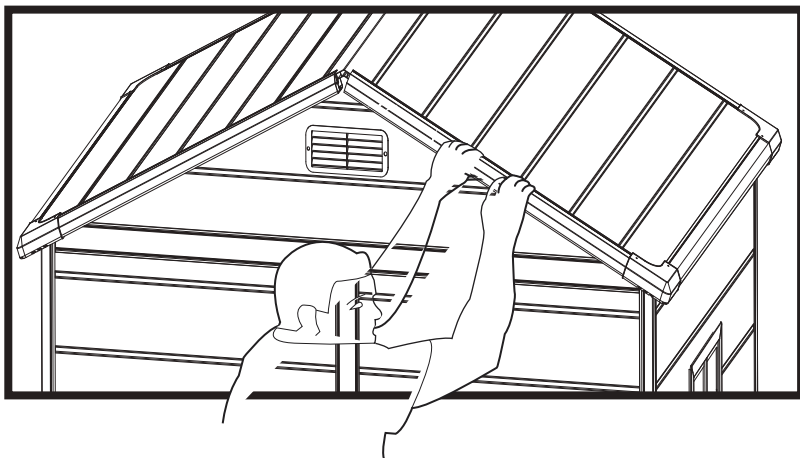

Fully fit the panels inside the profiles of roof

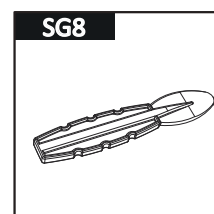

Step 50

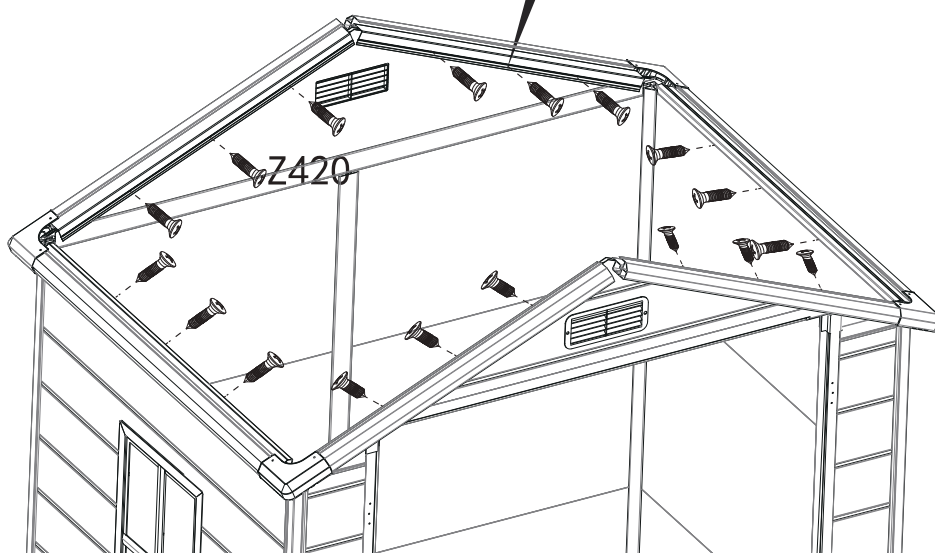
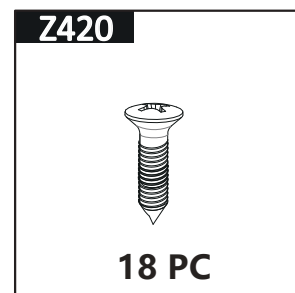
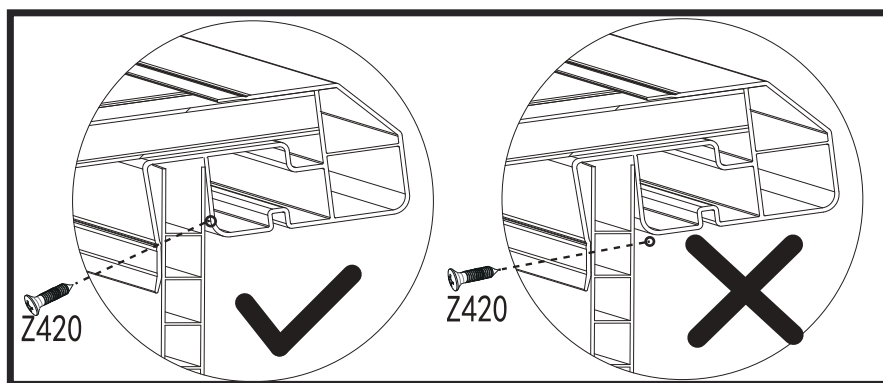

Step 51

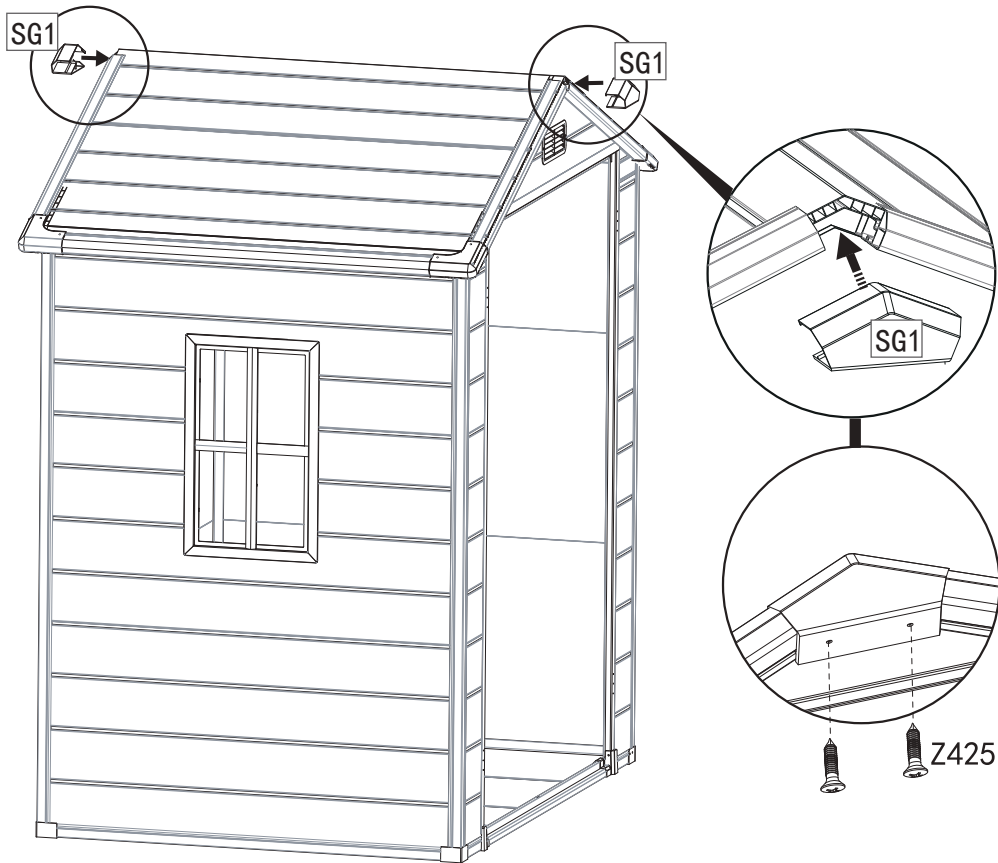

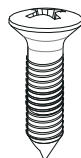
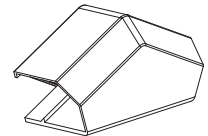
Z425

4 PC
SG1

2 PC

DOOR SECTION

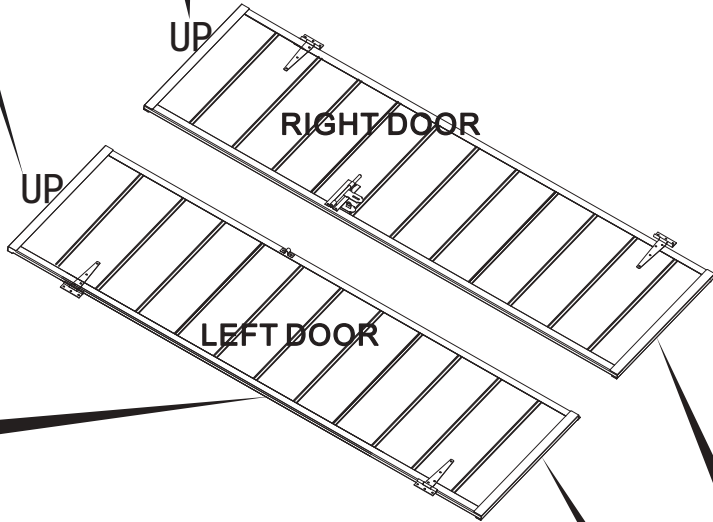

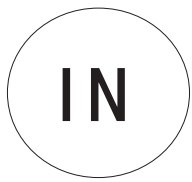
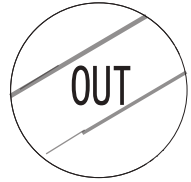
Door mount this is above



	
---	---

The stripes should be outside

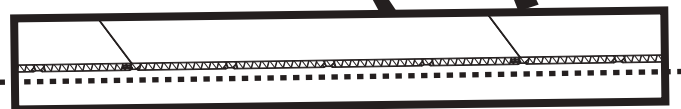

The boards must be straight

Step 52

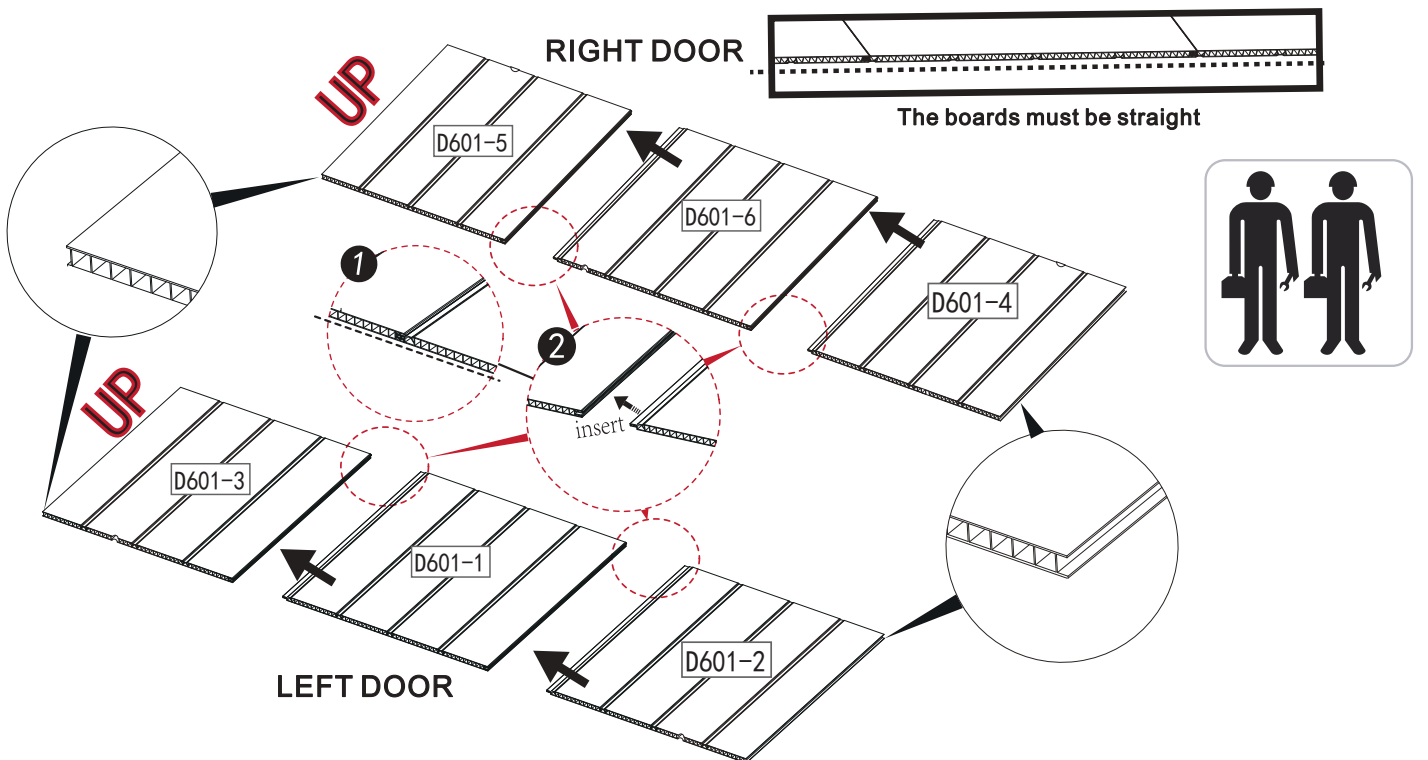
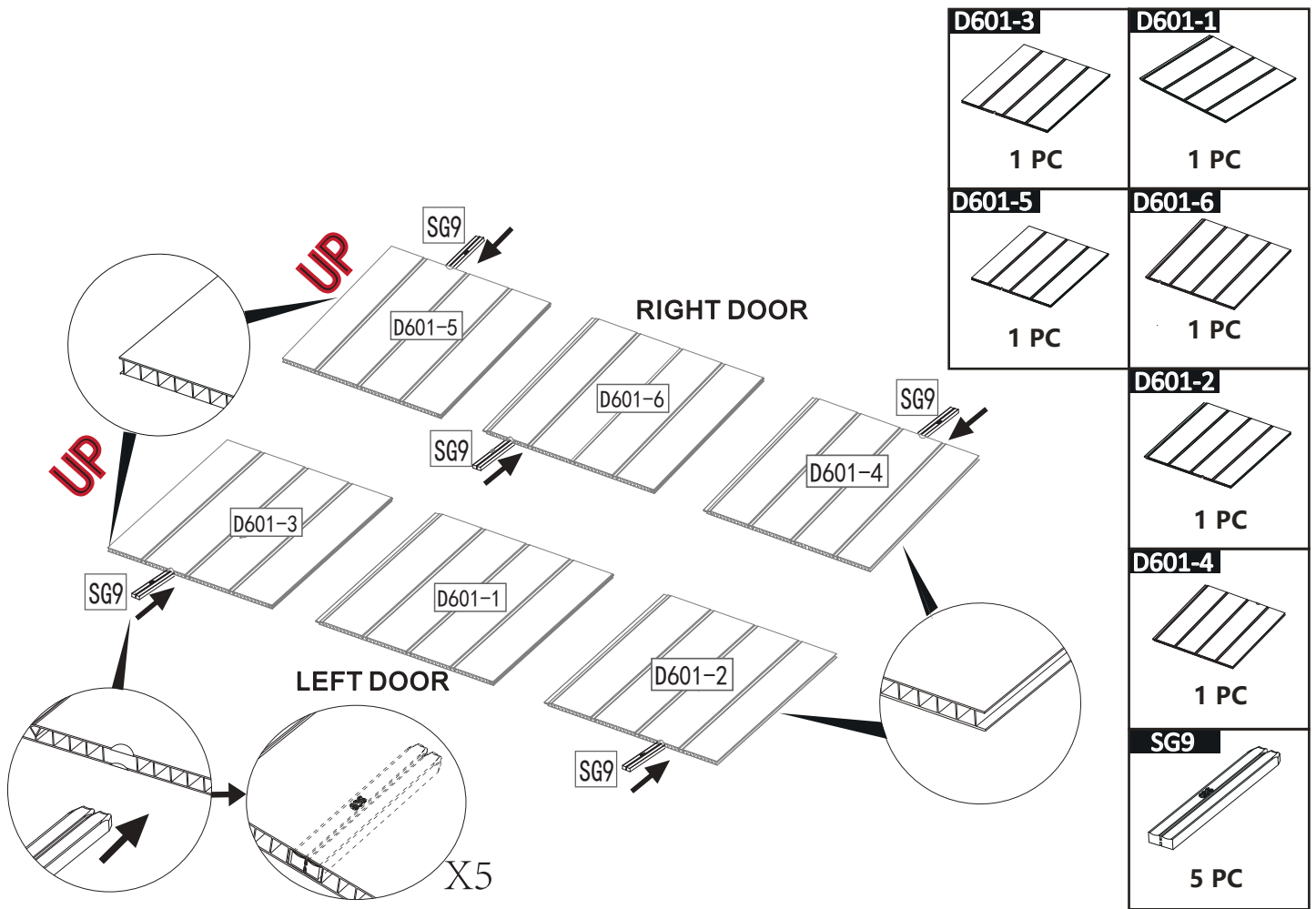

Step 53

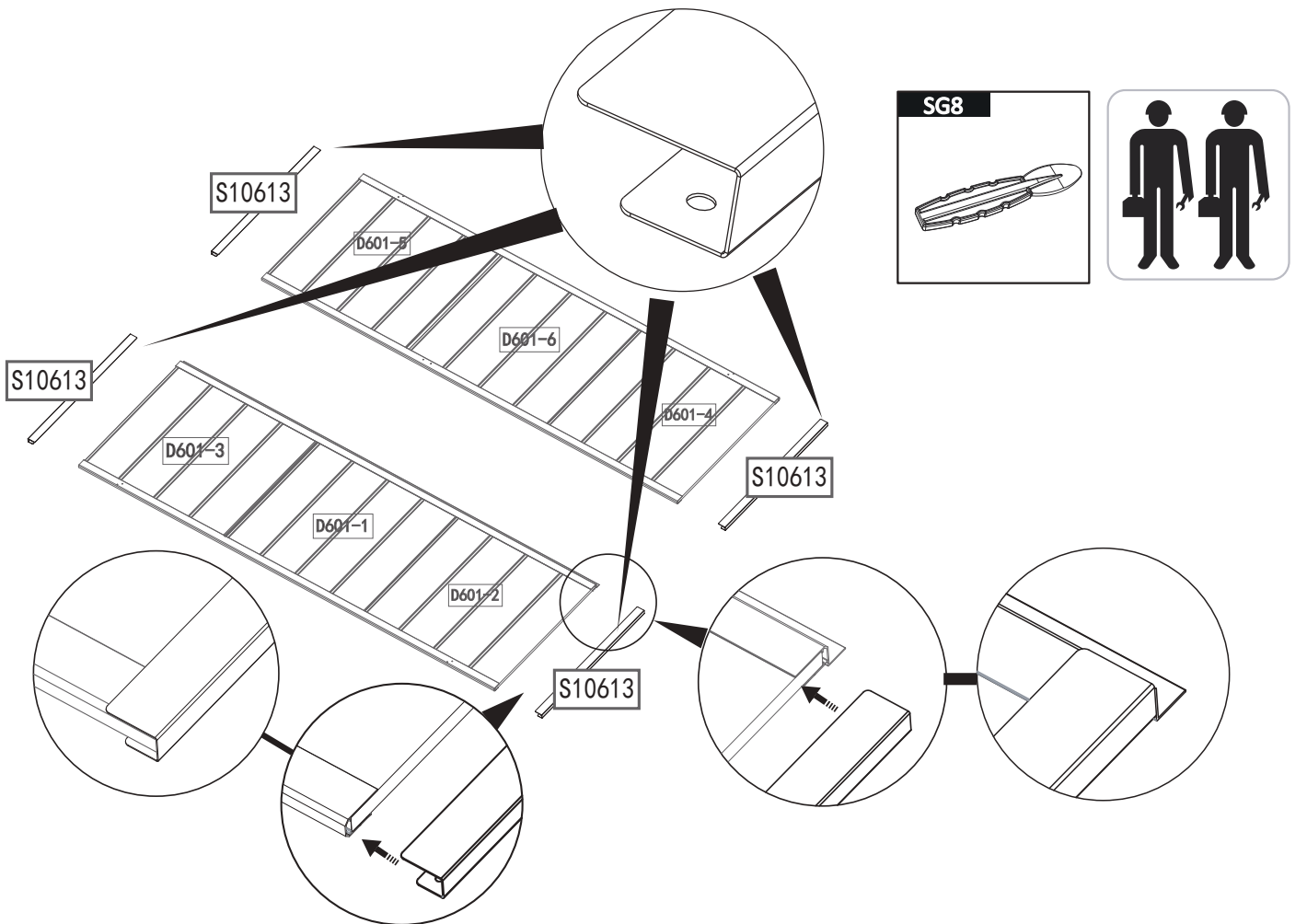
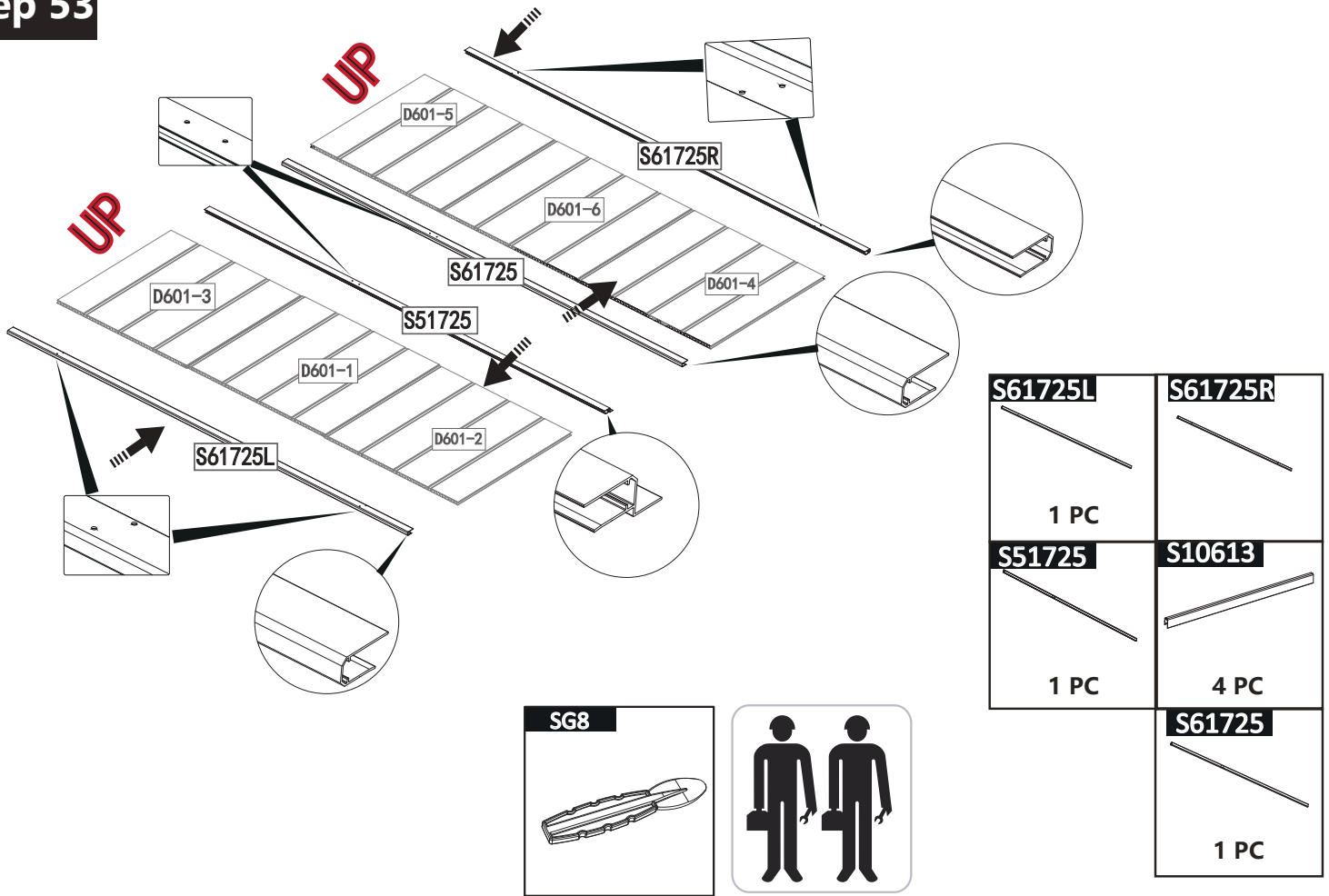

Step 54

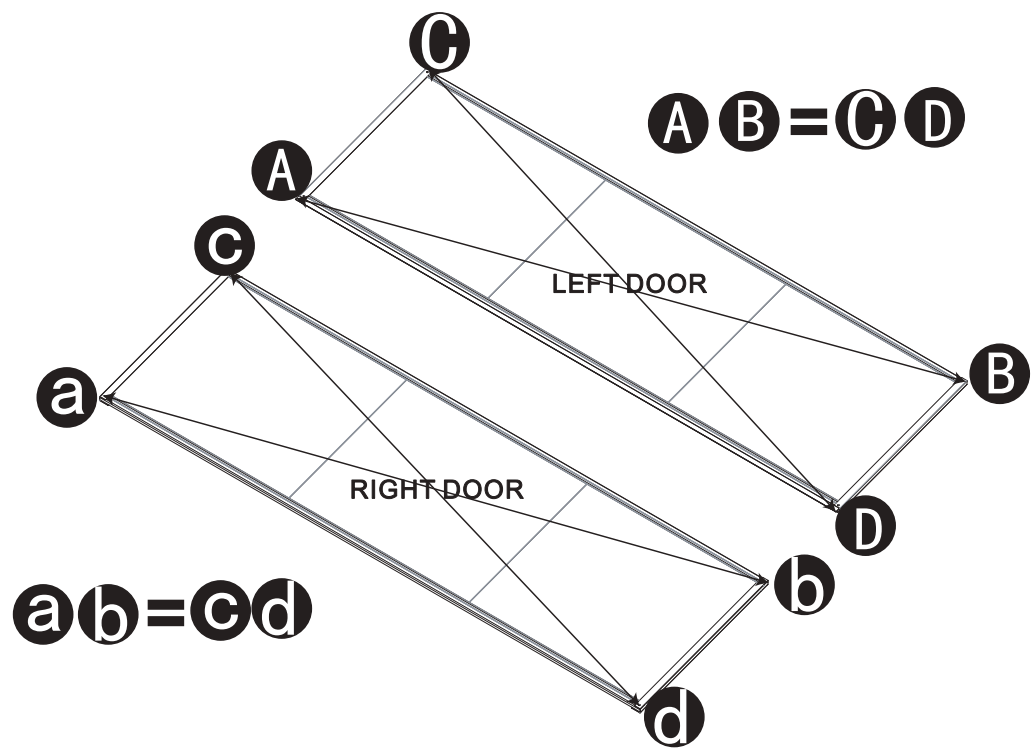
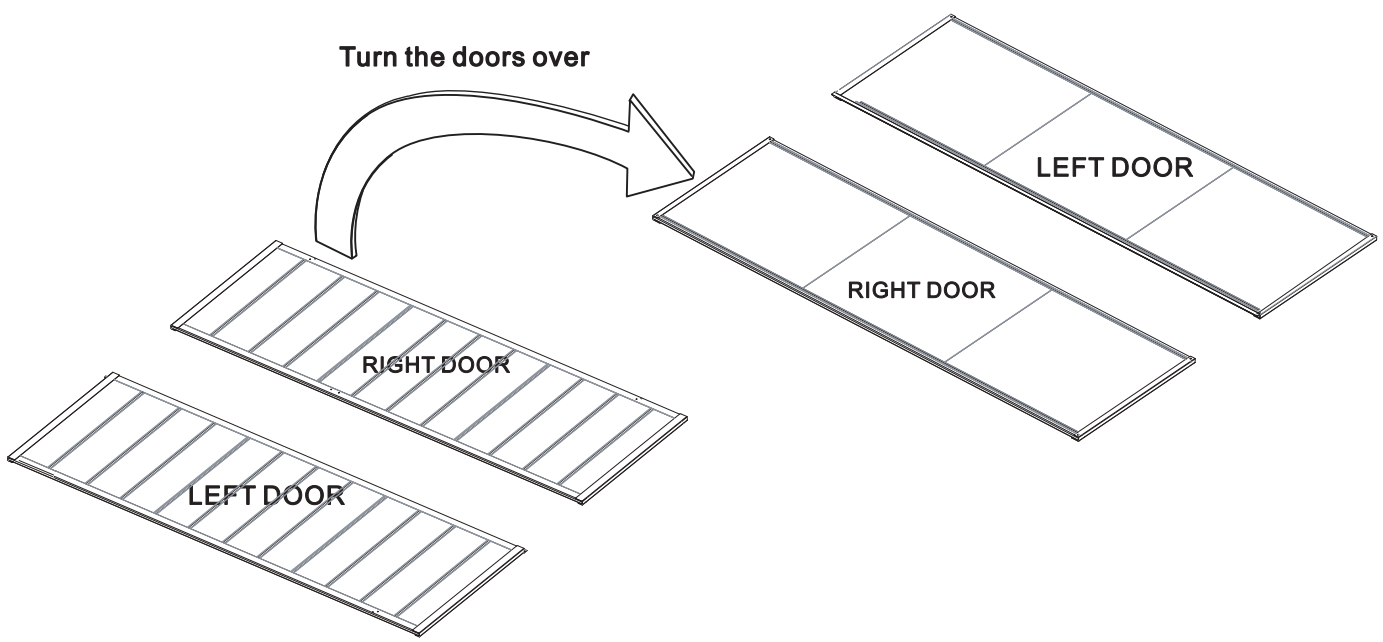
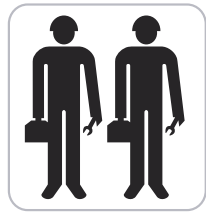

Step 55

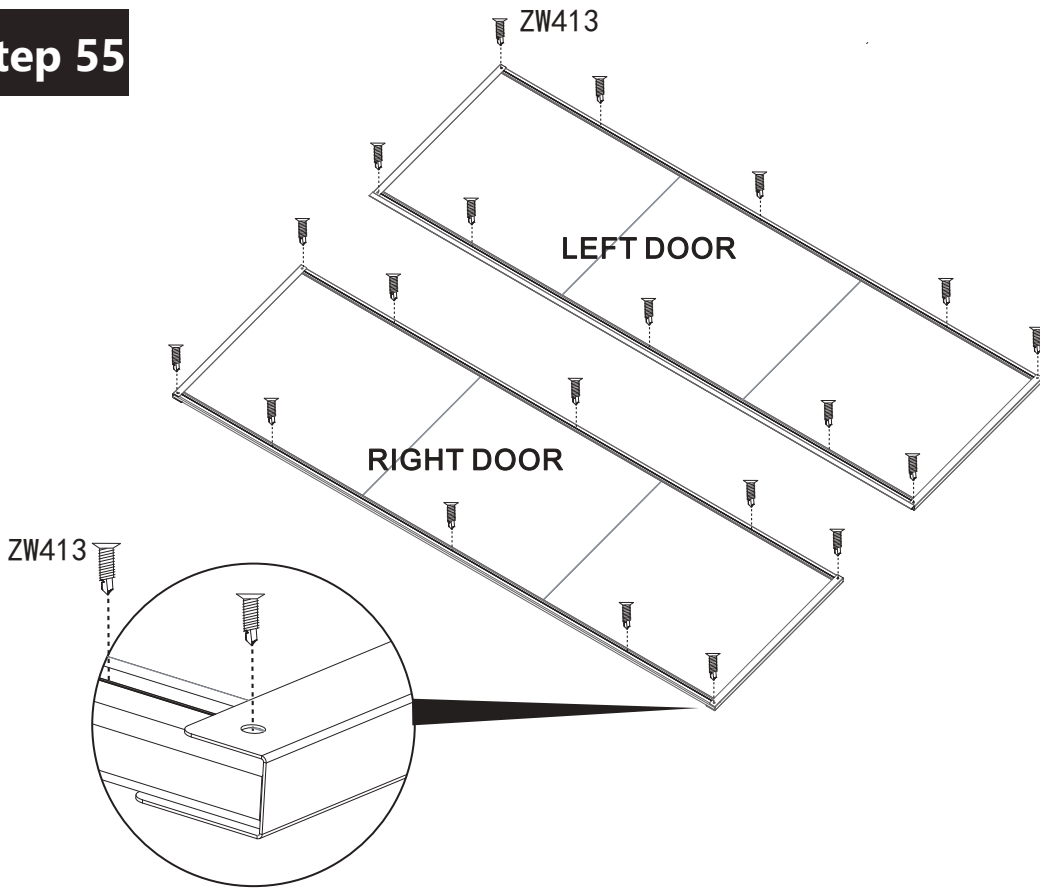

ZW413



20PC

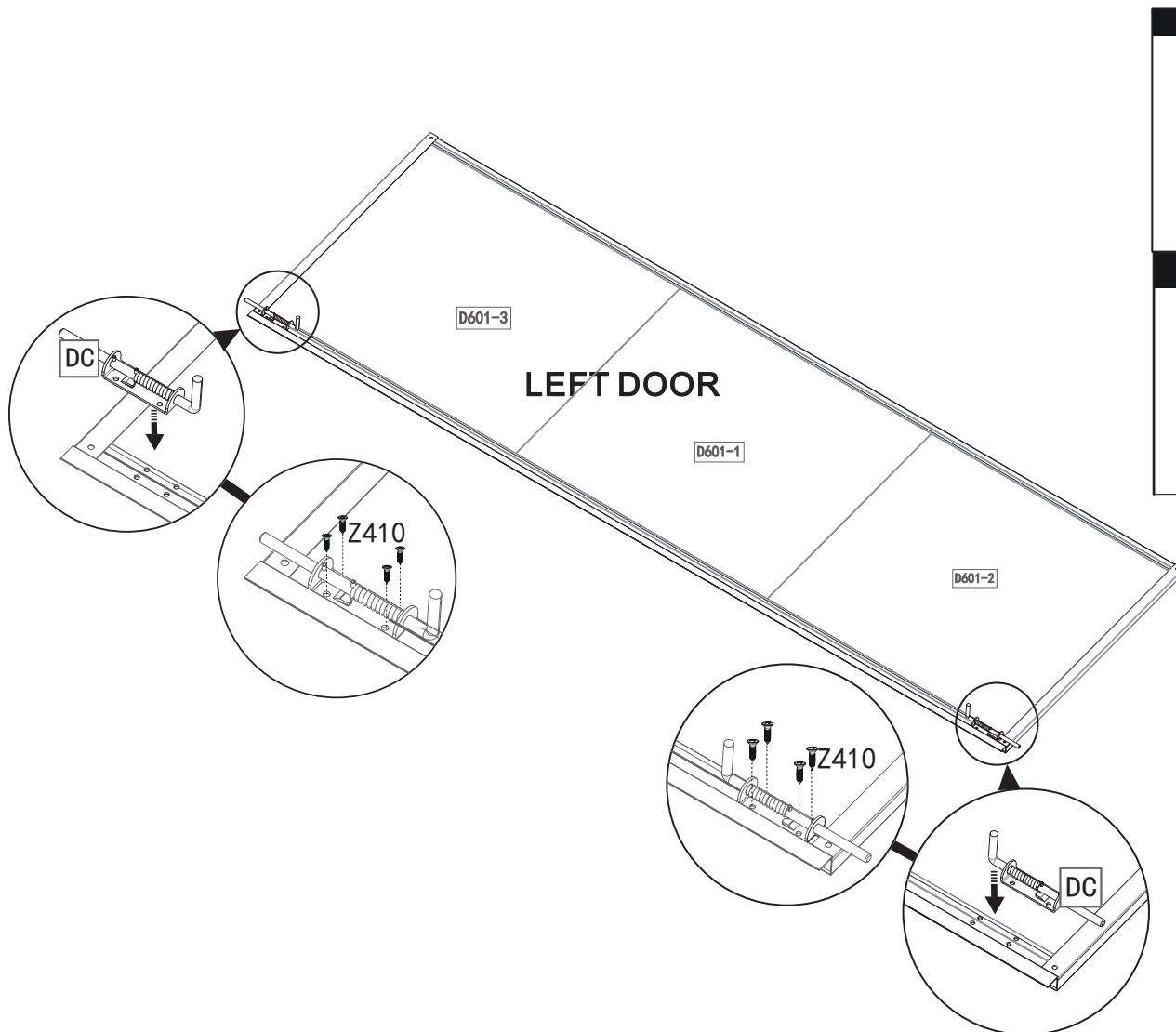

DC

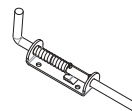

2 PC

Z410



8 PC

Step 56

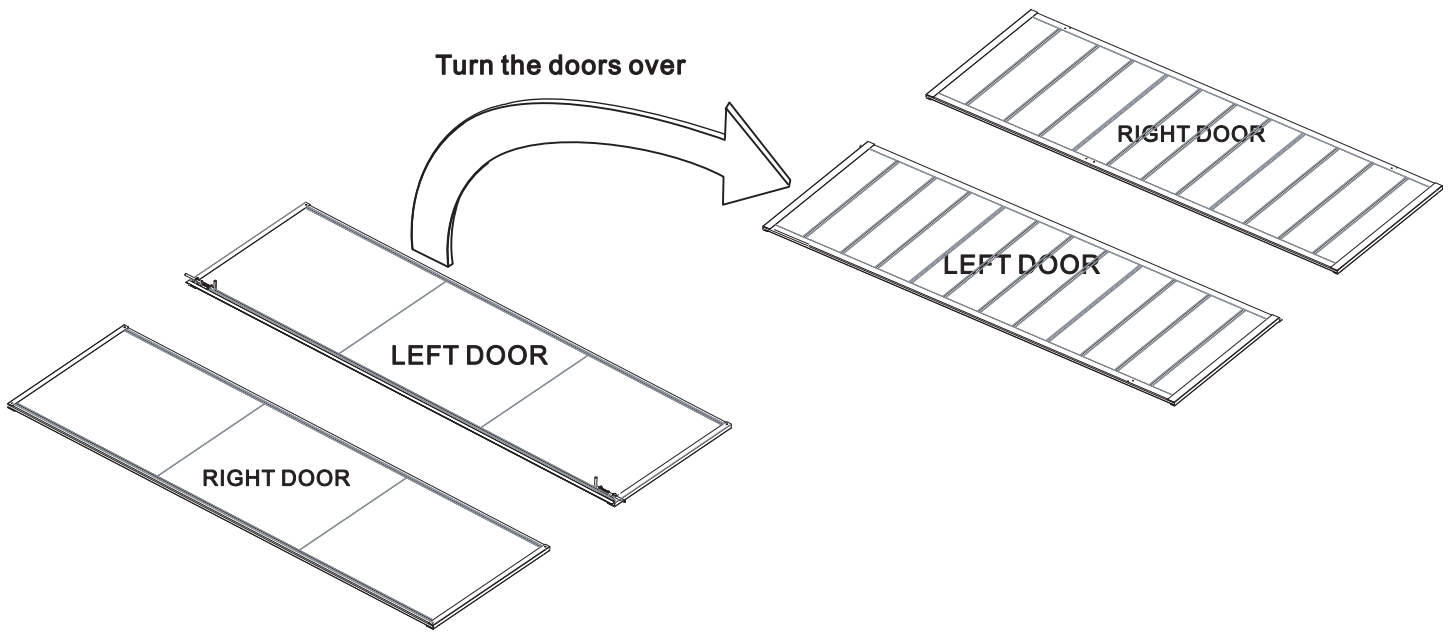

Step 57

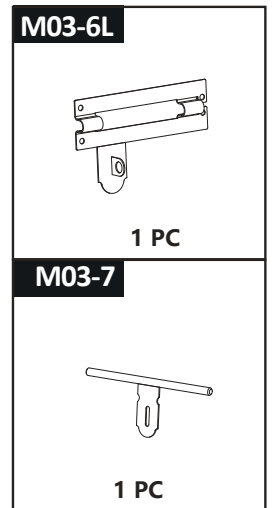
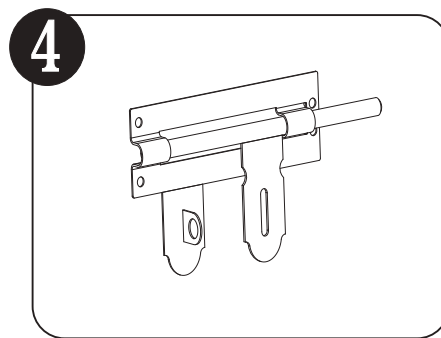
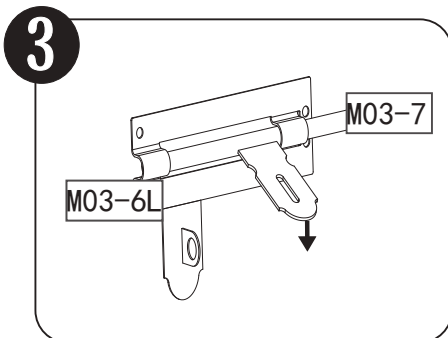
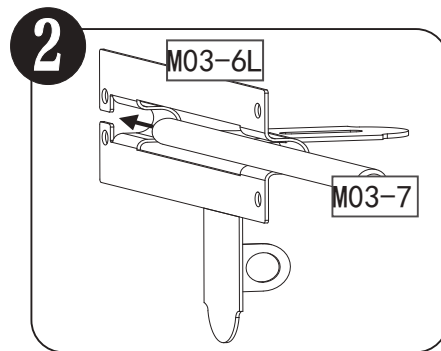
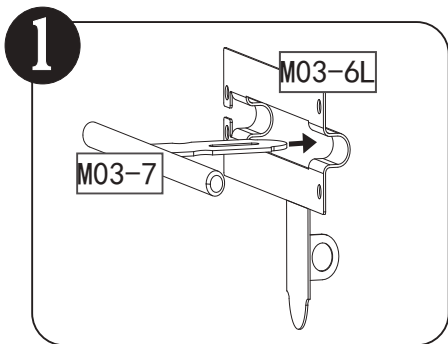

Step 58

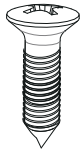
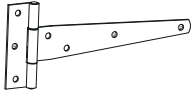
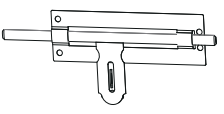
Z410

12 PC
MO1

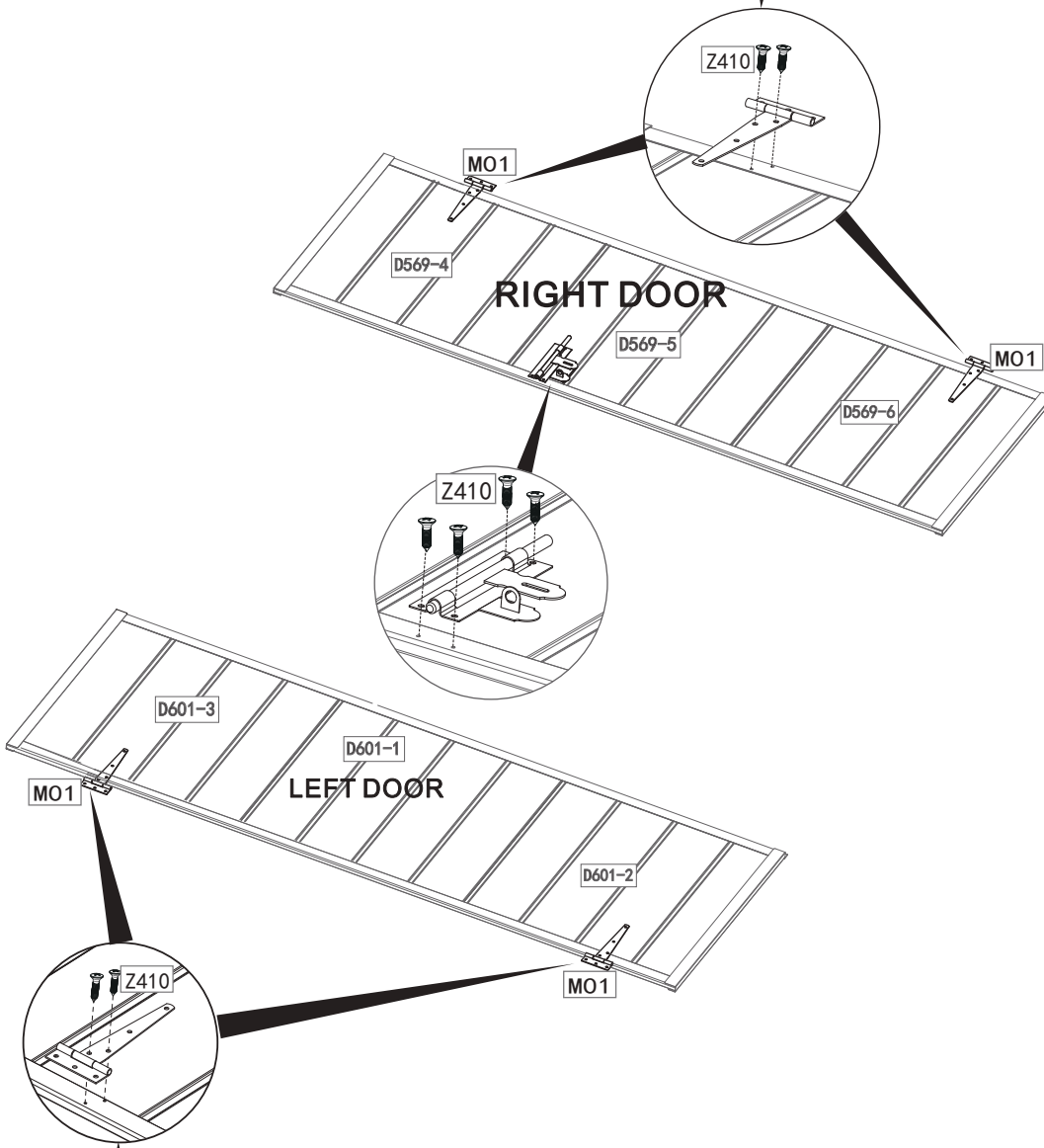
4 PC

1 PC

Don't fasten the screws in this step, to adjust the positions of doors

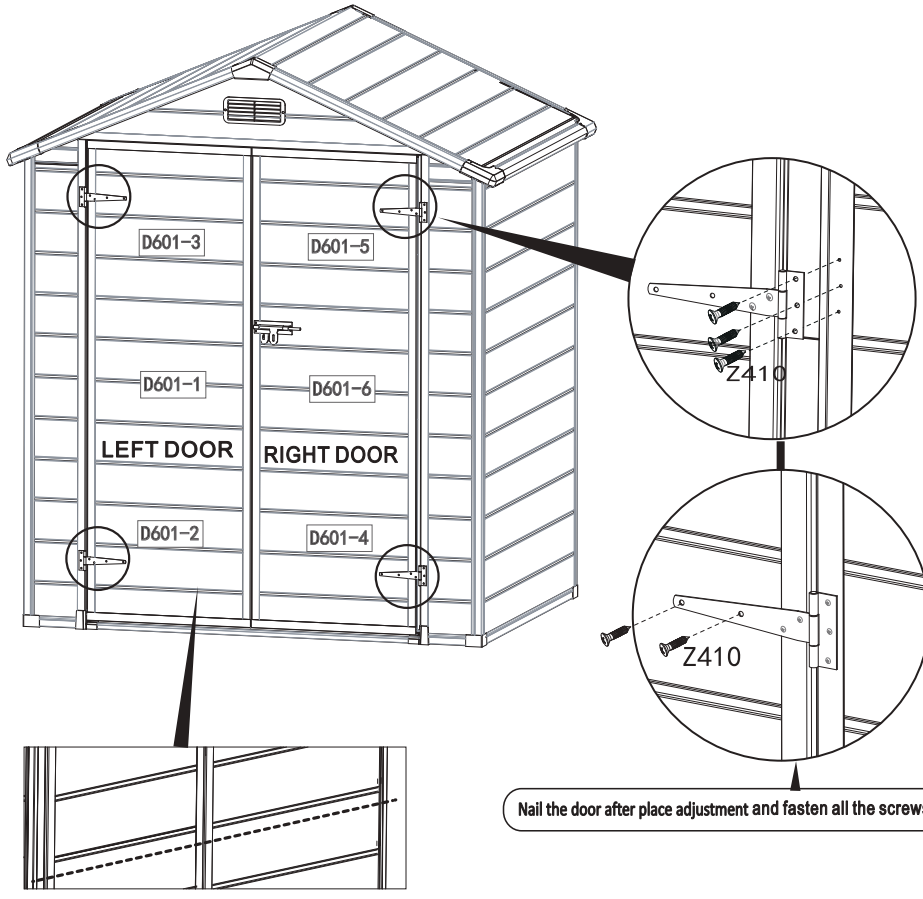

Don't fasten the screws in this step, to adjust the positions of doors

Step 59



Z410

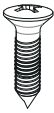

20 PC

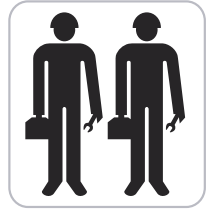

The joints of both left and right door should be in line

Step 60

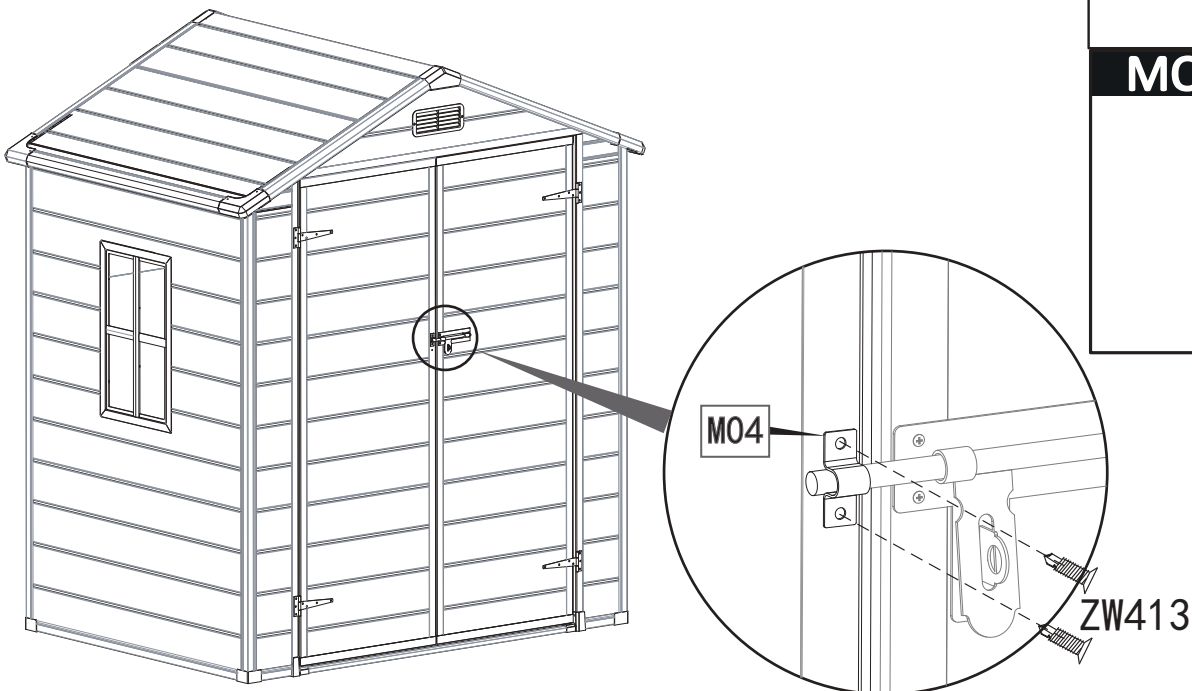

ZW413

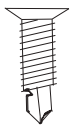

2 PC

M04

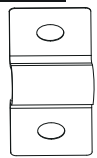

1 PC

Step 61



The seal can effectively prevent the rain from entering

1 Open the door

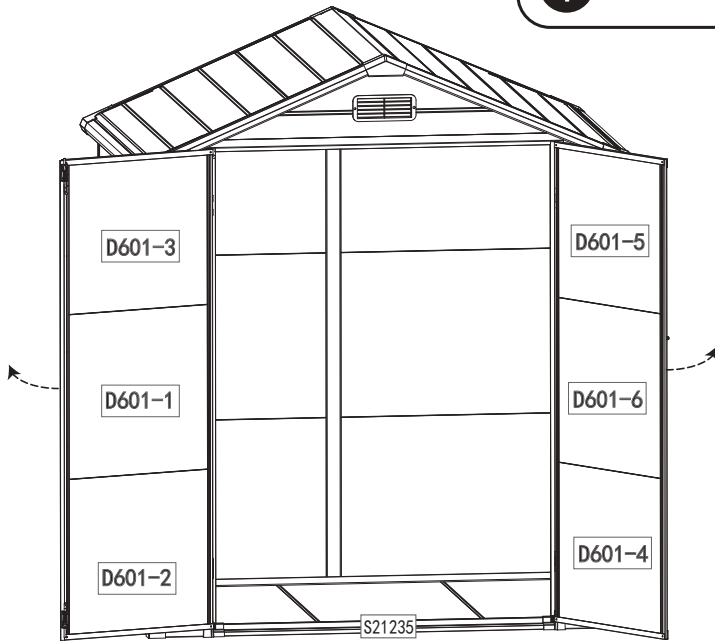

Sealing-1

1 PC

Sealing-2

2 PC

2 Please remove the plastic film from the sealing strip

Sealing -2

Sealing -1

3 Attach sealing strips as shown

