

ASSEMBLY INSTRUCTIONS

METAL GARDEN SHED

SKU: T-PS23-0230A

BE
YOUR
LIFE BUILDER

www.patiowell.com



 Patiowell

Metal Garden Shed
Installation Tutorial

[https://www.patiowell.com/
pages/video-t-ps23-0230a](https://www.patiowell.com/pages/video-t-ps23-0230a)

 saleservice@patiowell.com

BEFORE YOU BEGIN

Owner's Manual

Before beginning construction, check local building codes regarding footings, location and other requirements. Study and understand this owner's manual. Important information and helpful tips will make your construction easier and more enjoyable.

Assembly Instructions: Instructions are supplied in this manual and contain all appropriate information for your building model. Review all instructions before you begin and during assembly, follow the step sequence carefully for correct results.

Parts and Parts List: Check to be sure that you have all the necessary parts, you're your building Separate contents of the carton by the part number while reviewing parts list. The first few steps show how to join related parts to make larger sub assemblies which will be used later. Familiarize yourself with the hardware and fasteners for easier use during construction.

These are packaged within the carton. Note that extra fasteners have been supplied for your convenience.

PLAN AHEAD

Watch the Weather: Be sure the day you select to install your building is dry and calm. Do not attempt to assemble your building on a windy day. Be careful on wet or muddy ground.

Teamwork: Whenever possible, two or more people should work together to assemble your building. One person can position parts or panels while the other is able to handle the fasteners and the tools.

Tools and Materials: These are some basic tools and materials you will need for the construction of your building. Decide which method of anchoring and the type of foundation you wish to use in order to form a complete list of the materials you will need.

CARE & MAINTENANCE

Finish: For long lasting finish, periodically clean and wax the exterior surface. Touch-up scratches as soon as you notice them on your unit. Immediately clean the area with a wire brush; wash it and apply touch-up paint per manufacturer's recommendation.

Roof: Keep roof clear of leaves and snow with long handled, soft-bristled broom, Heavy amounts of snow on roof can damage building making it unsafe to enter. In snow country, Roof Strengthening Kits are available for most Arrow Buildings for added protection against heavy snow accumulation.

Doors: Always keep the door tracks clear of dirt and other debris that prevent them from sliding easily. Lubricate door track annually with furniture polish or silicone spray, Keep doors closed and locked to prevent wind damage.

Fasteners: Use all washers supplied to protect against weather infiltration and to protect the metal from being scratched by screws. Regularly check your building for loose screws, bolts, nuts, etc, and retighten them as necessary.





Moisture: A plastic sheet (vapor barrier) placed under the entire floor area with good ventilation will reduce condensation.

Other Tips....



Wash off inked part numbers on coated panels with soap and water
Silicone caulking may be used for watertight seals throughout the building.

Do not store swimming pool chemicals in your building, Combustibles and corrosives must be stored in air tight approved containers.

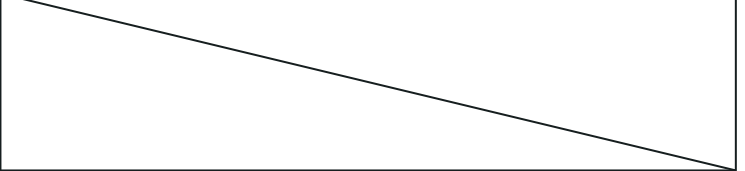
FOUNDATION

<p>BS1 X1</p> 	<p>BS2 X1</p> 
<p>BS1L X1</p> 	<p>BS2L X1</p> 
<p>BF3 X2</p> 	

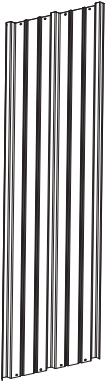

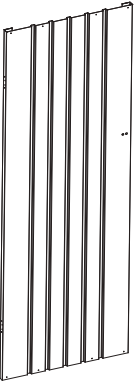
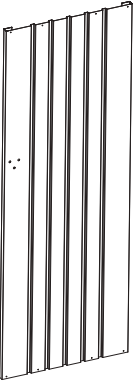
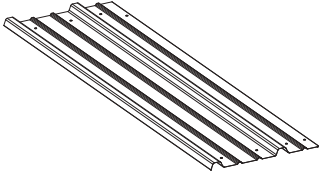
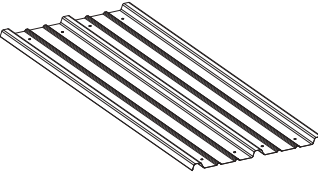
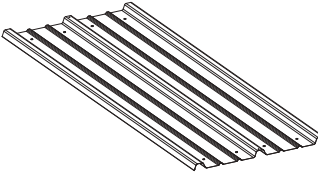
PLATES

 <p>W1A X7</p>	 <p>WS2A X4</p>	 <p>WS3A X2</p>	 <p>DLA X1</p>
 <p>DRA X1</p>	 <p>P1 X1</p>	 <p>P2 X2</p>	 <p>P3 X1</p>

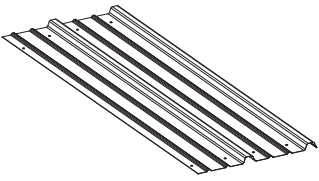
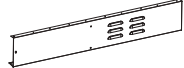
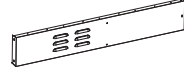
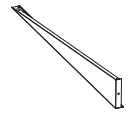
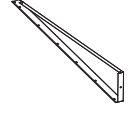

PLATES

 <p>P4 X1</p>	 <p>12L X1</p>	 <p>12R X1</p>	 <p>21L X1</p>  <p>21R X1</p>
---	---	--	---

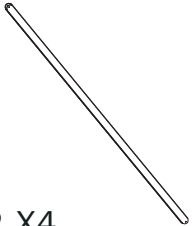
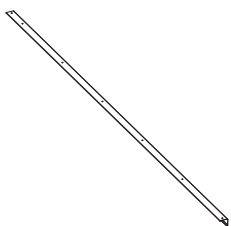
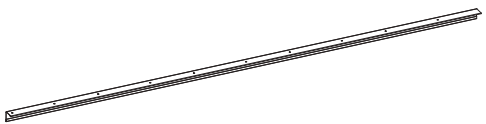
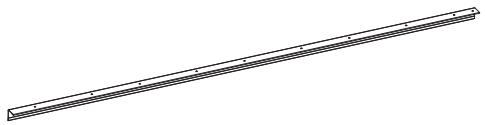
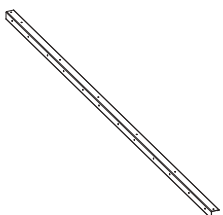



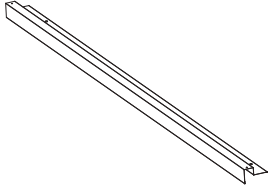
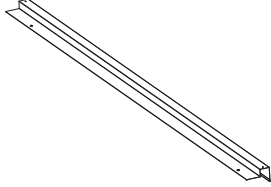
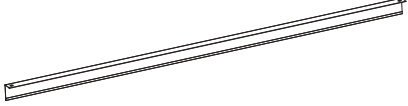
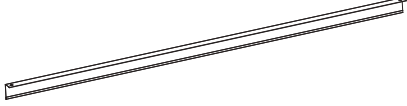

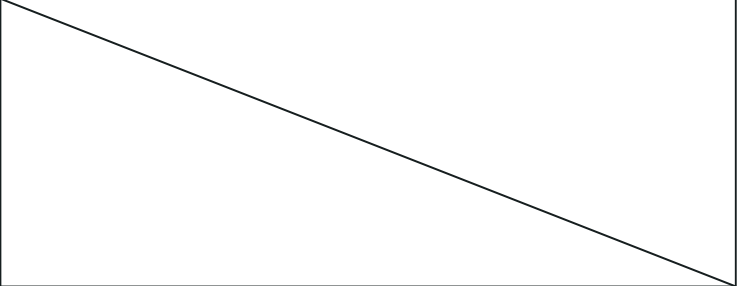
STRIPS

 <p>ULA X1</p>	 <p>UR1 X1</p>	 <p>B1 X4</p>	 <p>DX2 X4</p>
 <p>9 X1</p>		 <p>10L X1</p>	
 <p>10R X1</p>		 <p>11 X1</p>	

STRIPS

 <p>15 X1</p>	 <p>16 X1</p>
 <p>17 X2</p>	 <p>18 X2</p>
 <p>US1 X1</p>	

STANDARD

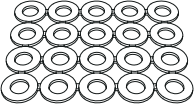
 <p>DC X2</p>	 <p>DH X4</p>	 <p>DF X1</p>	 <p>DG X1</p>
 <p>GC X4</p>	 <p>GS X1</p>	 <p>V1 X115</p>	 <p>V2 X175</p>

SCREW



M4x10

F1 X215



M4x10

F2 X8



M5x12

F3 X32

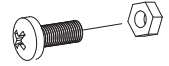

M6x10

F4 X5



M4x16

F5 X4

STRUCTURE VIEW

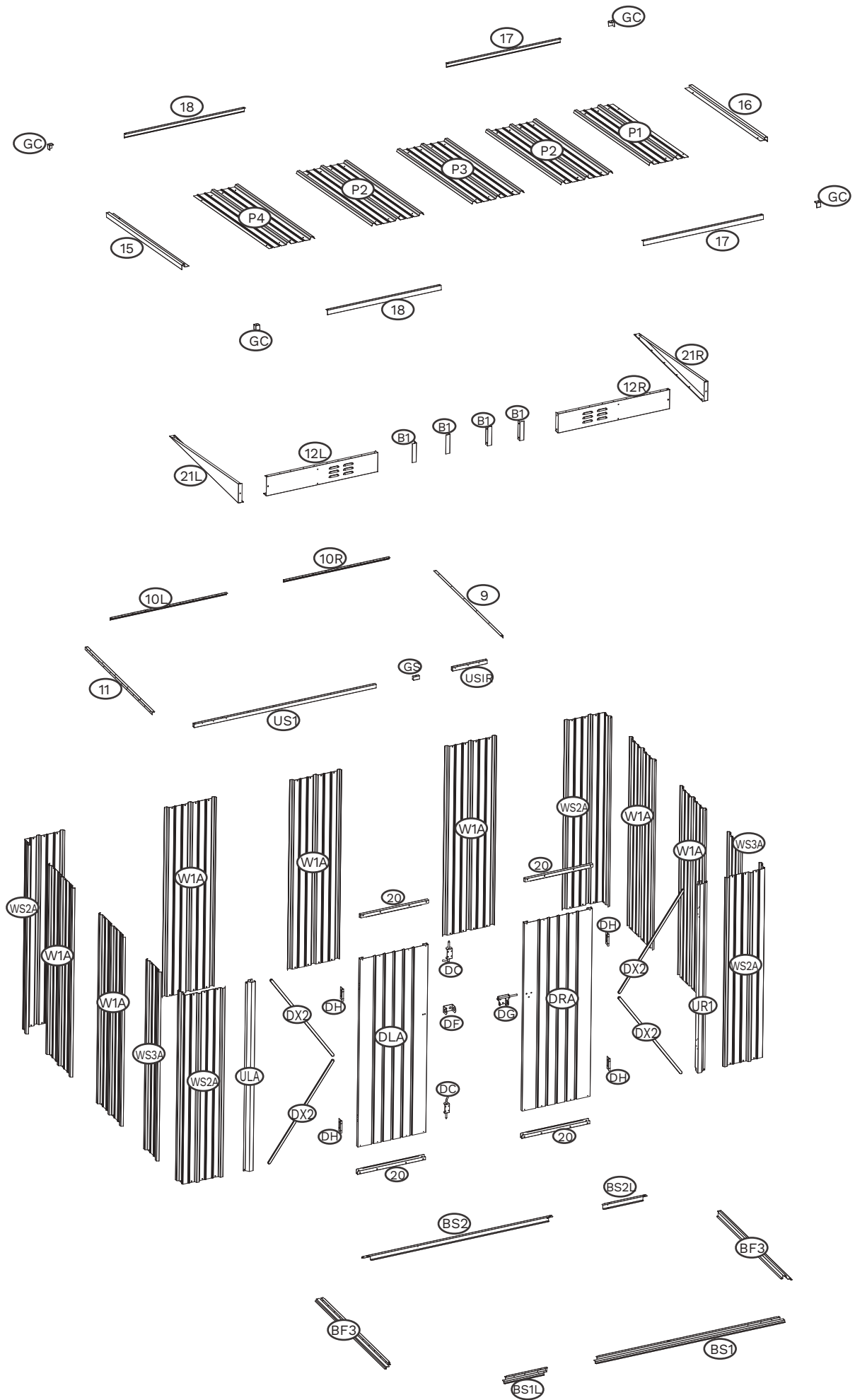

STEP 1

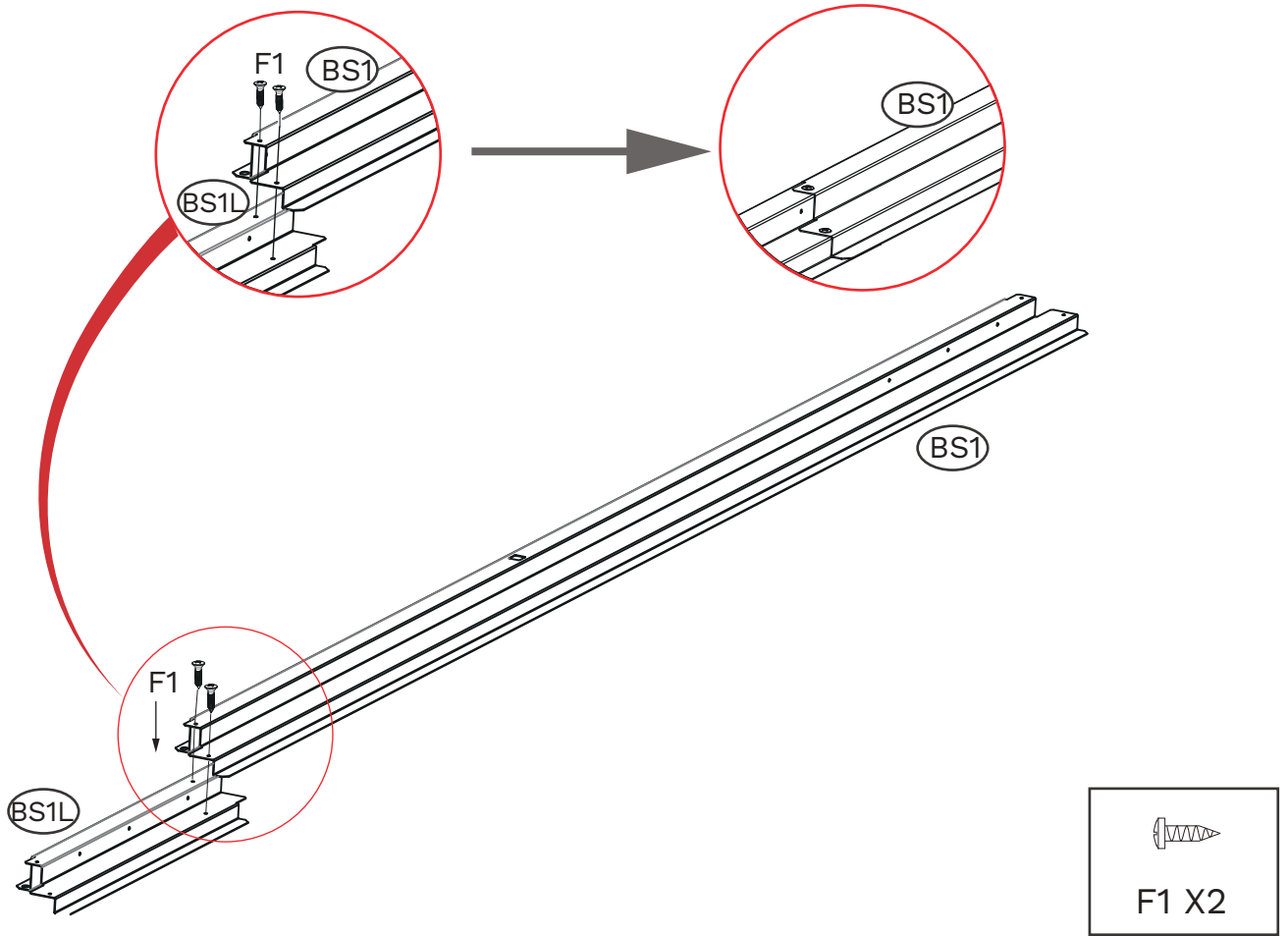

STEP 2

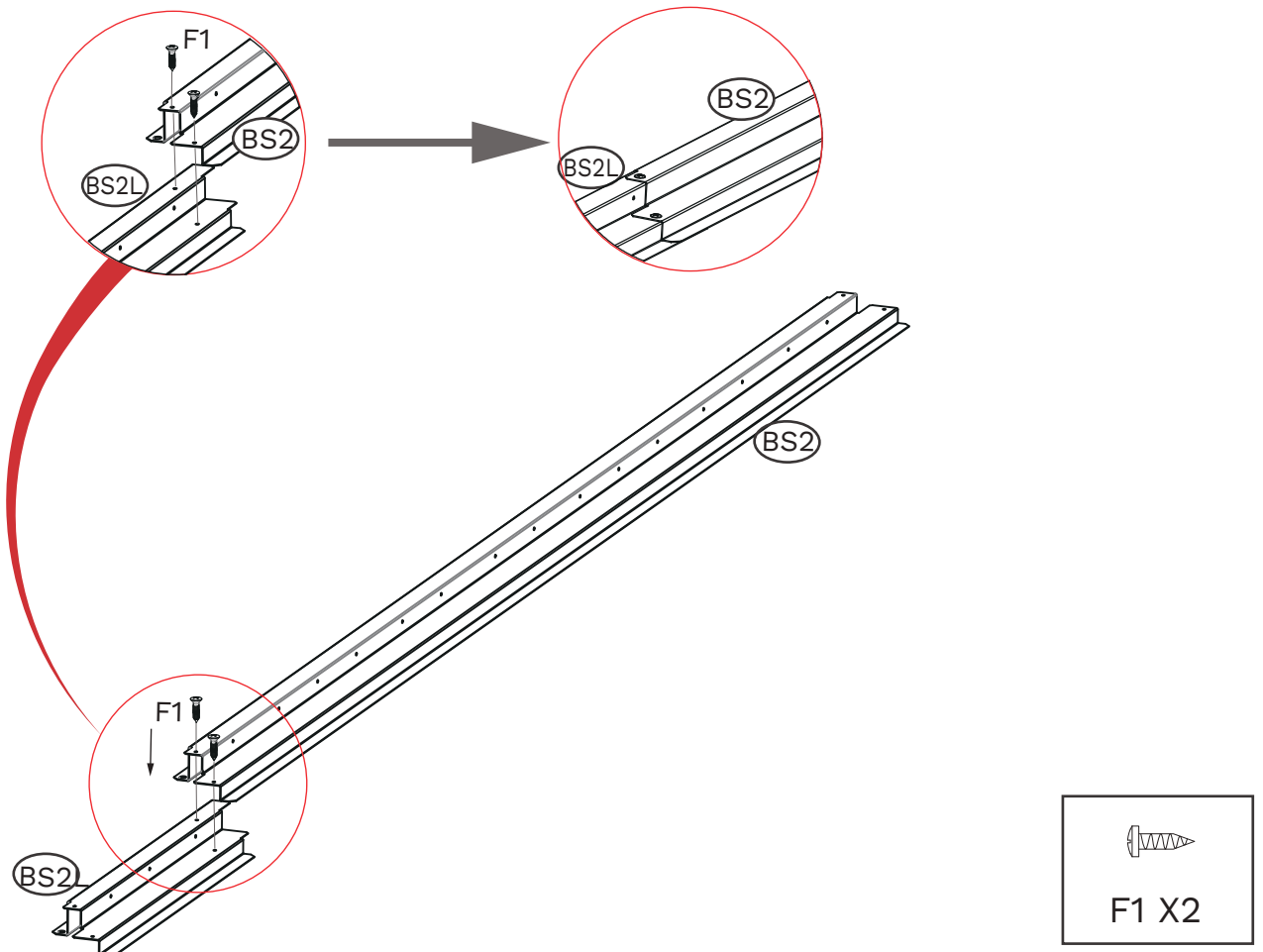

STEP 3

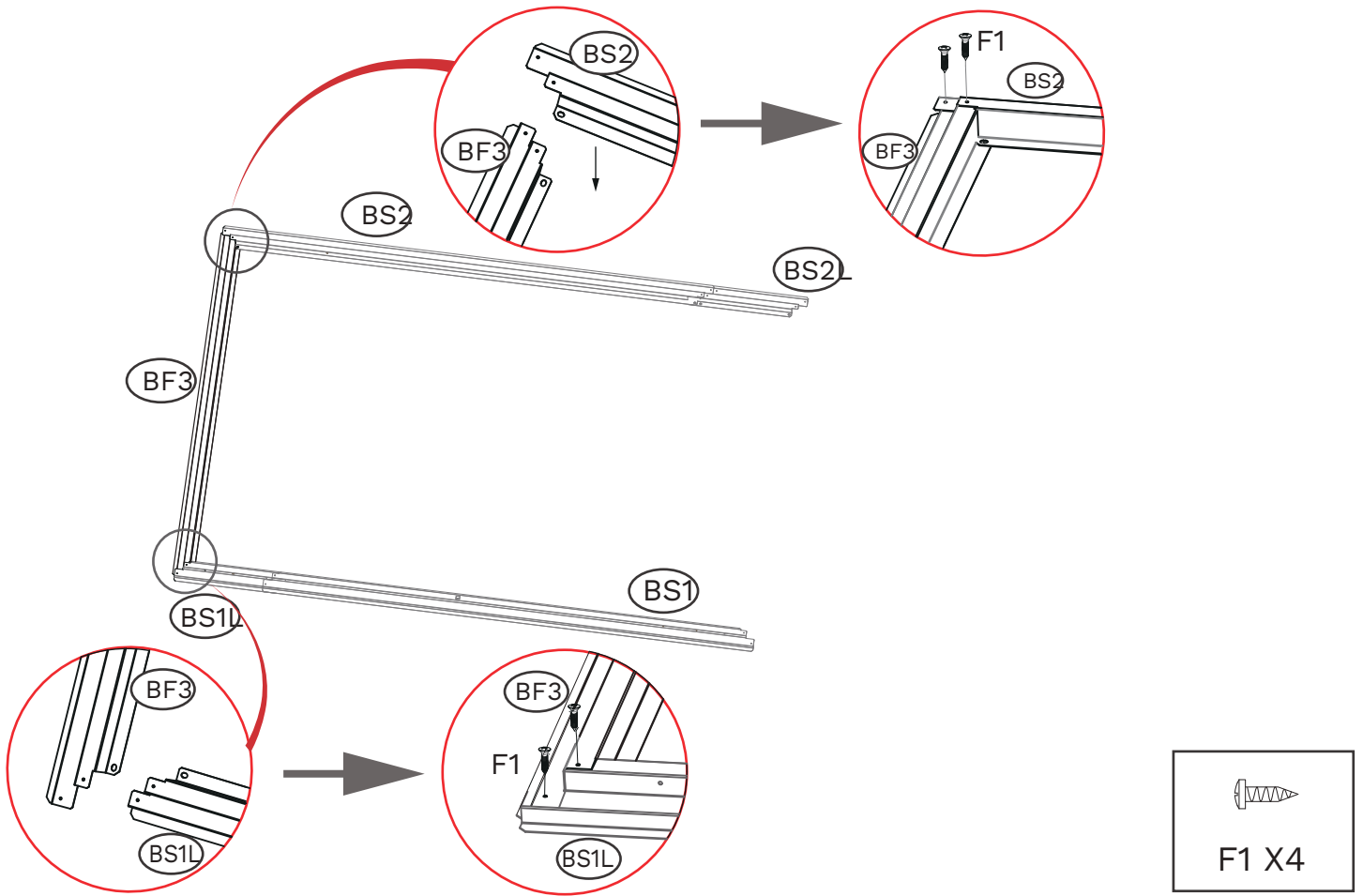

STEP 4

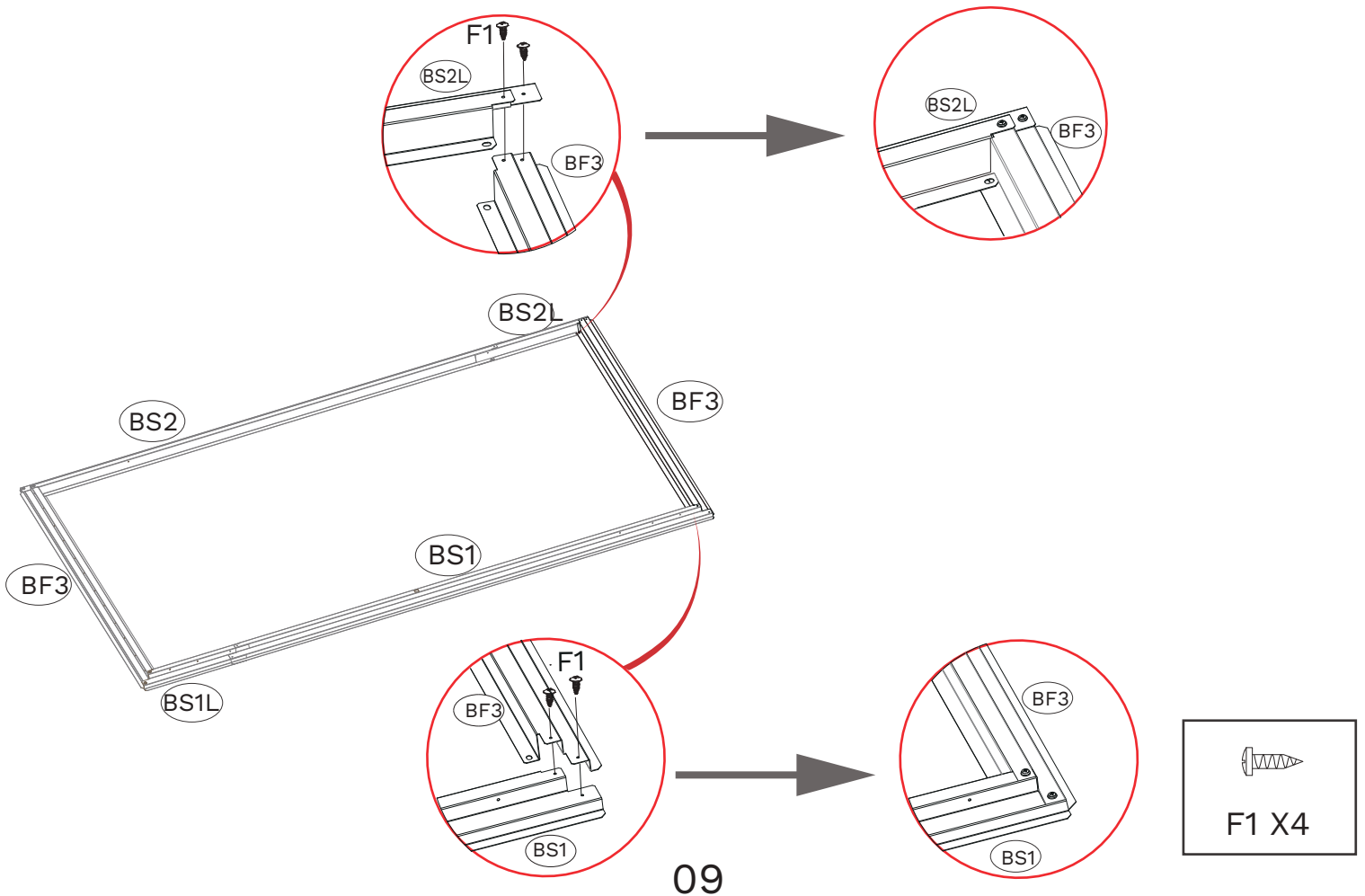

STEP 5

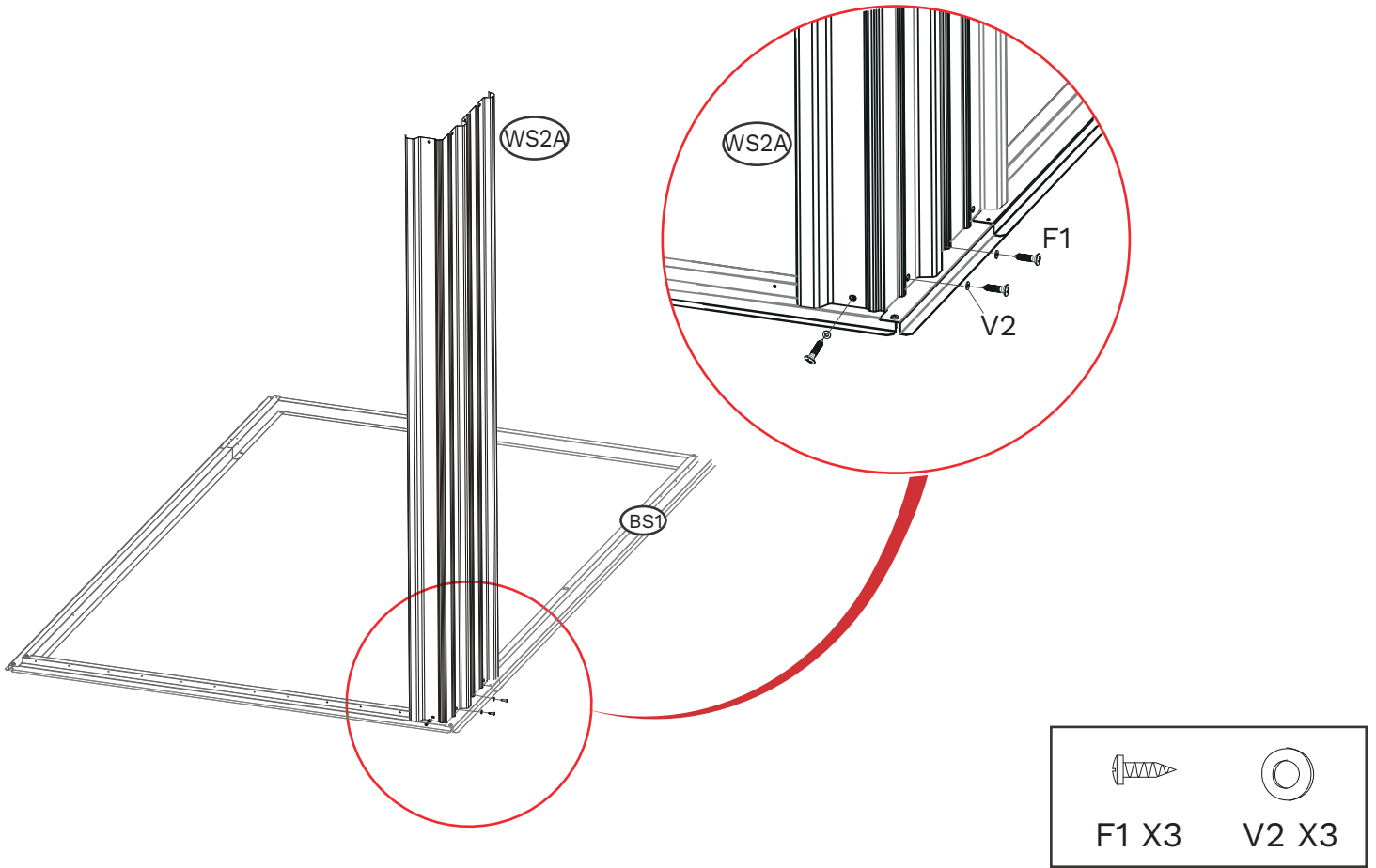

STEP 6

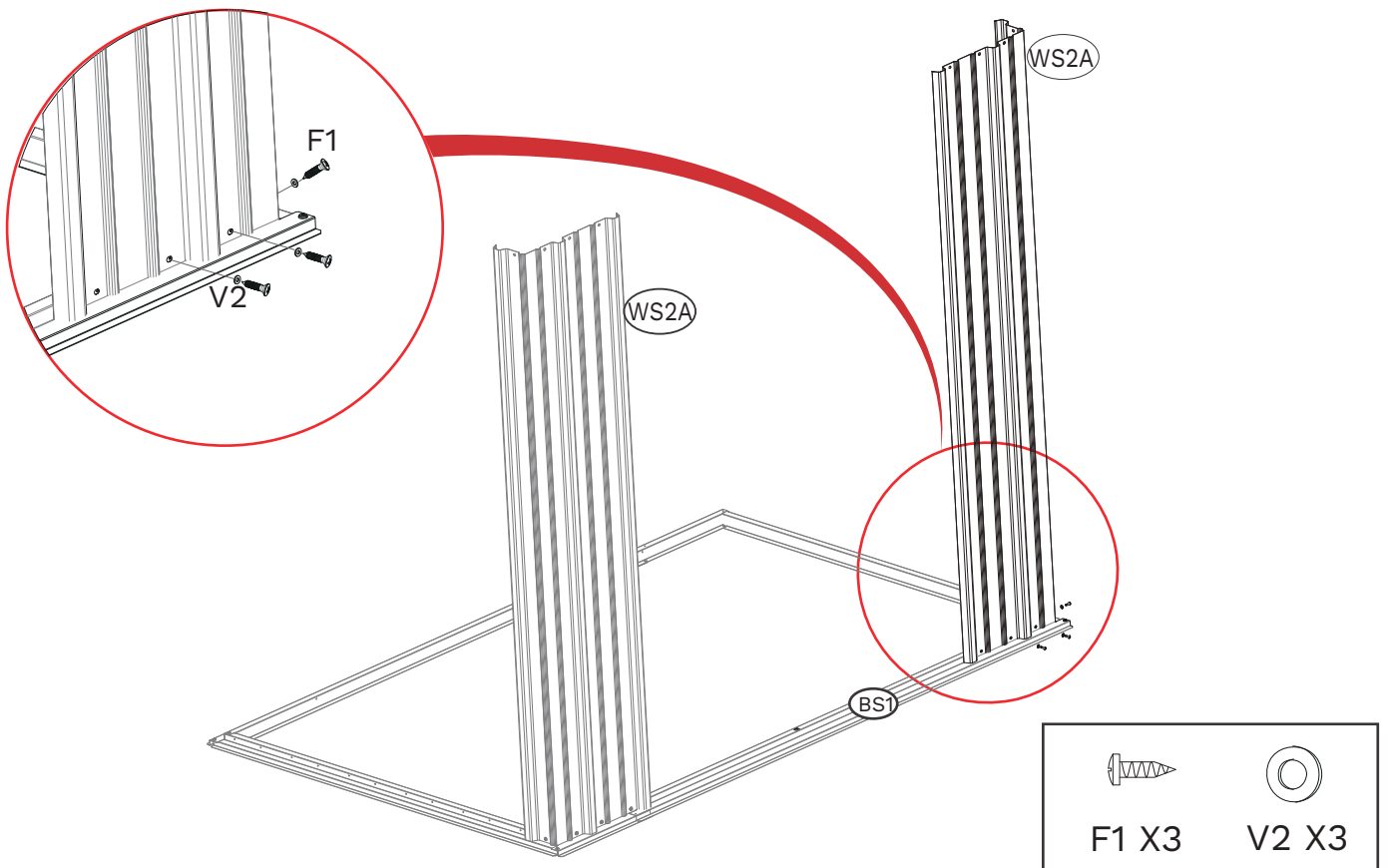

STEP 7

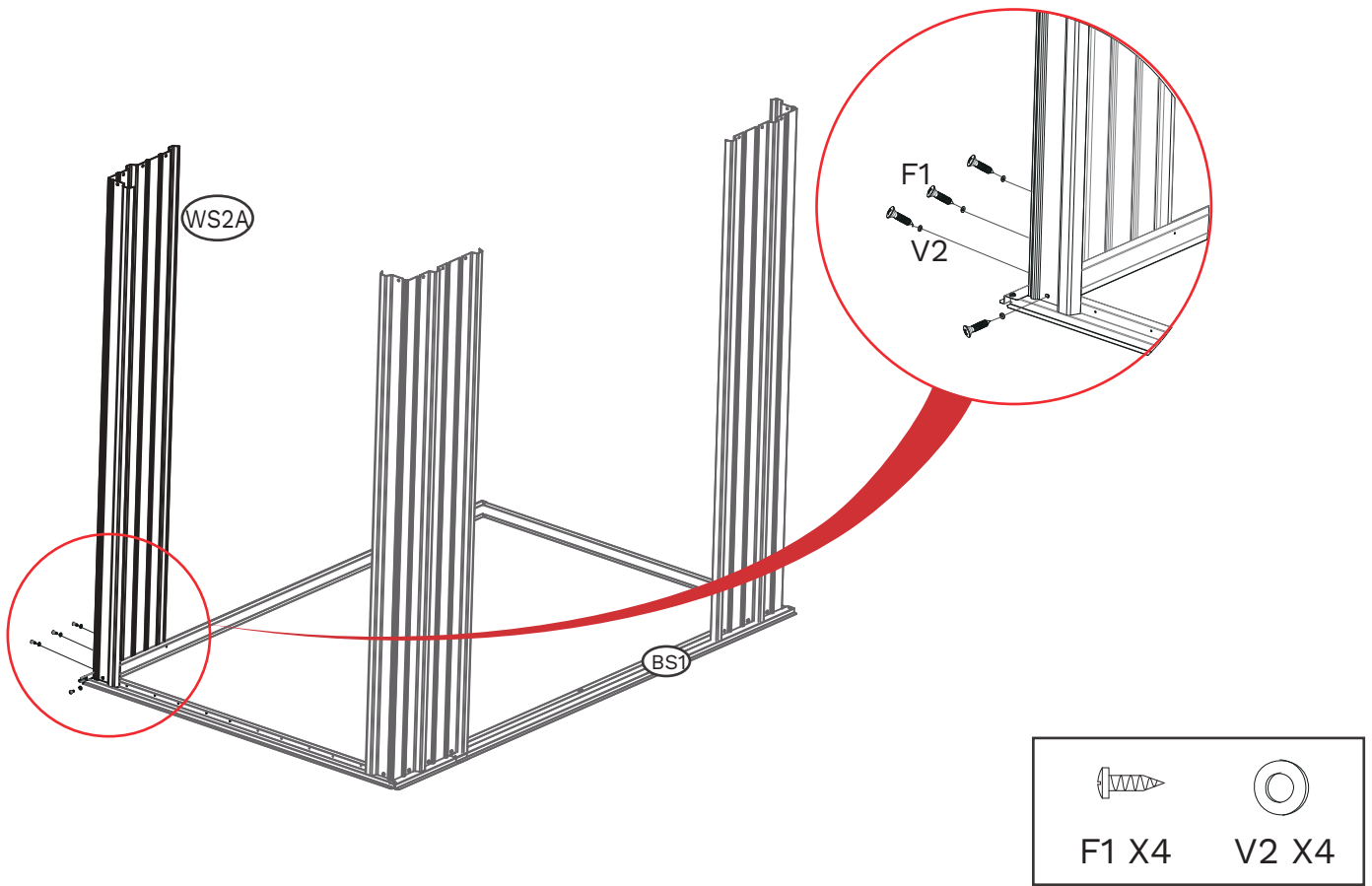

STEP 8

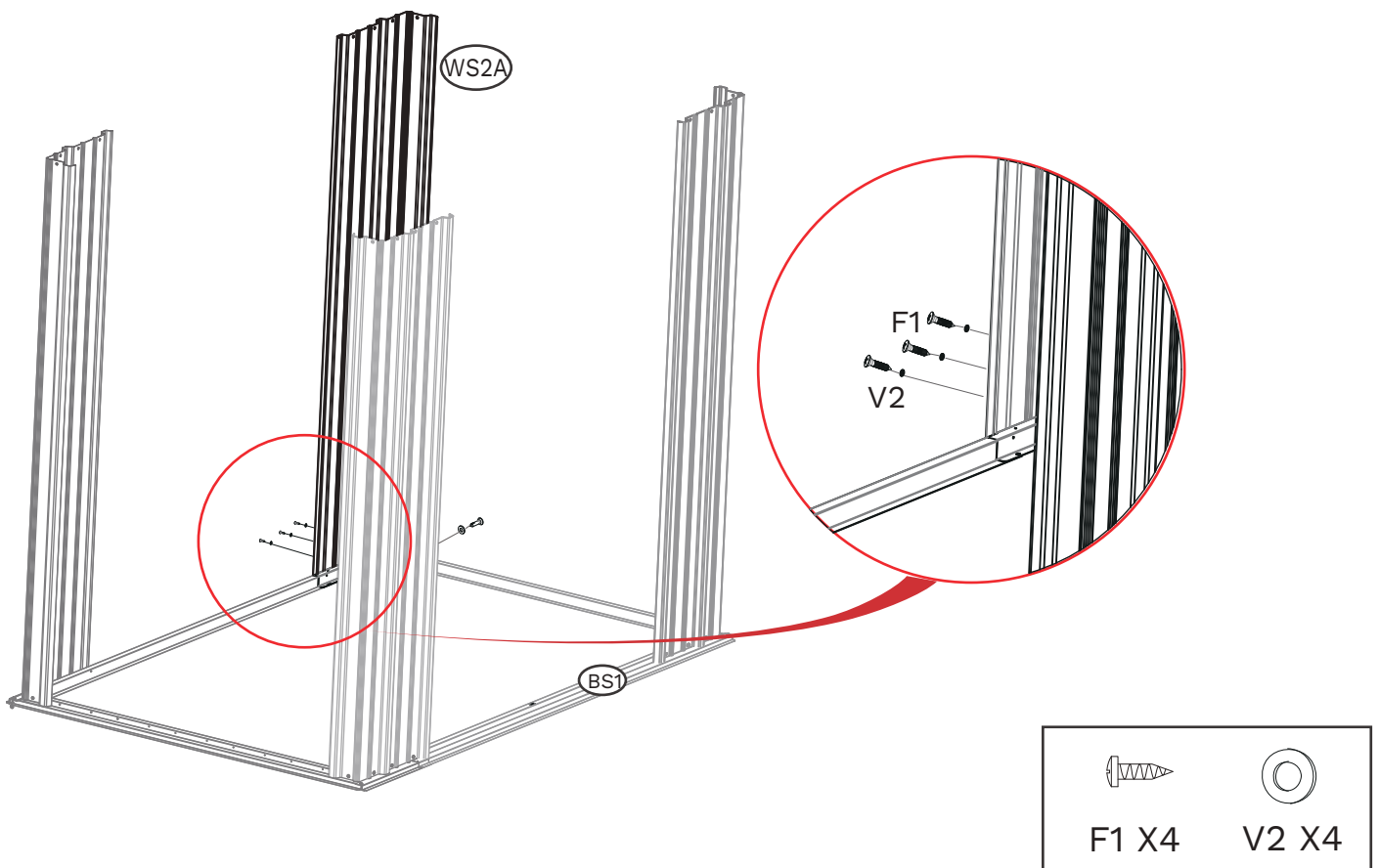

STEP 9

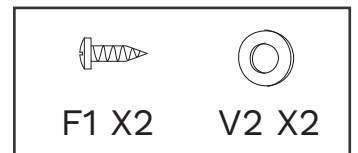
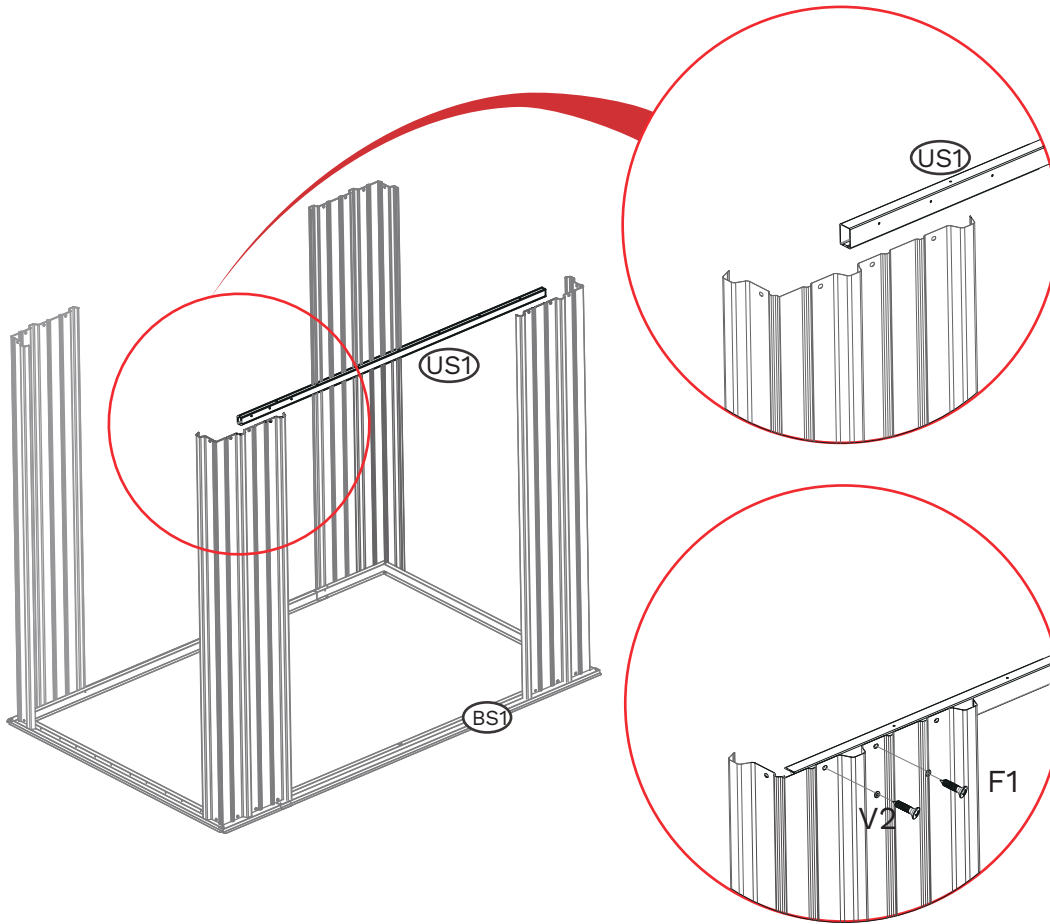

STEP 10

You can gently pull the wall panel to insert accessories.

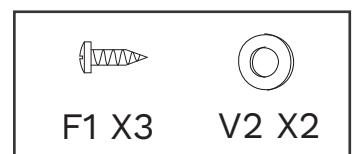
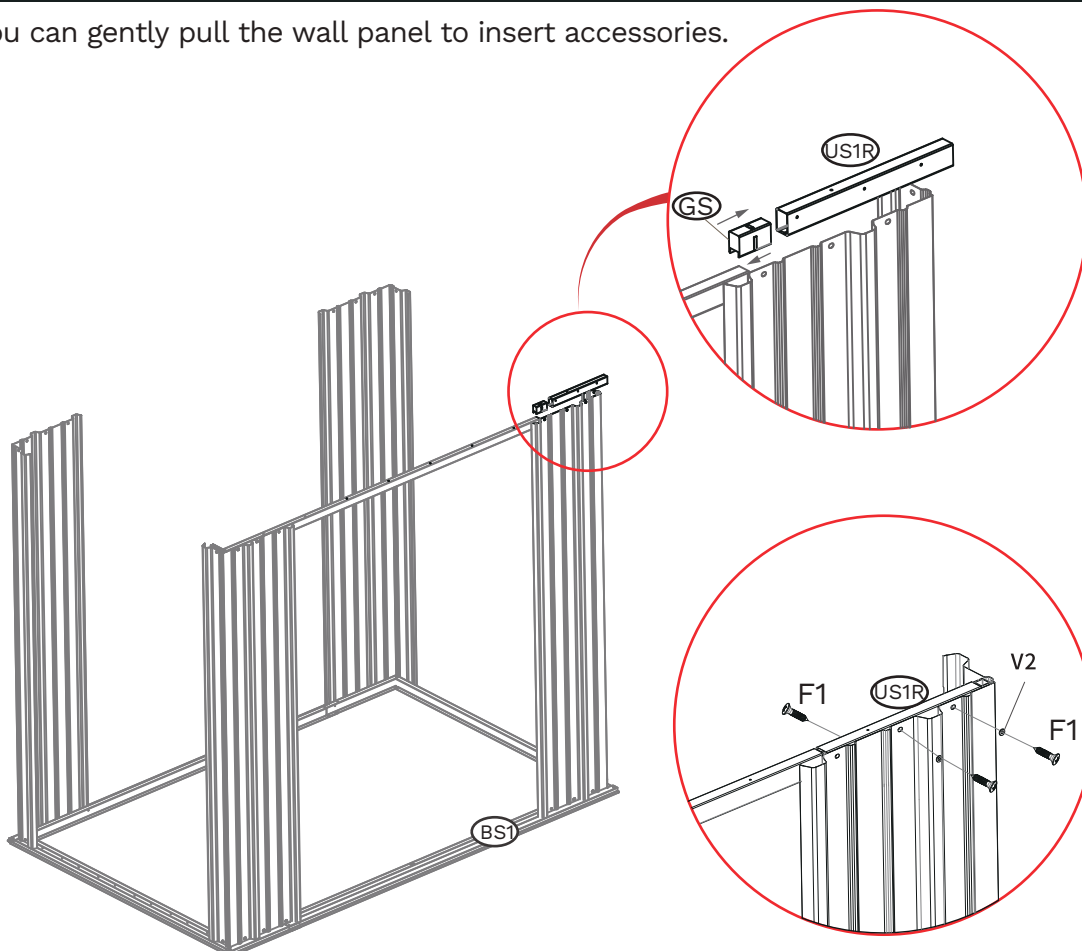

STEP 11

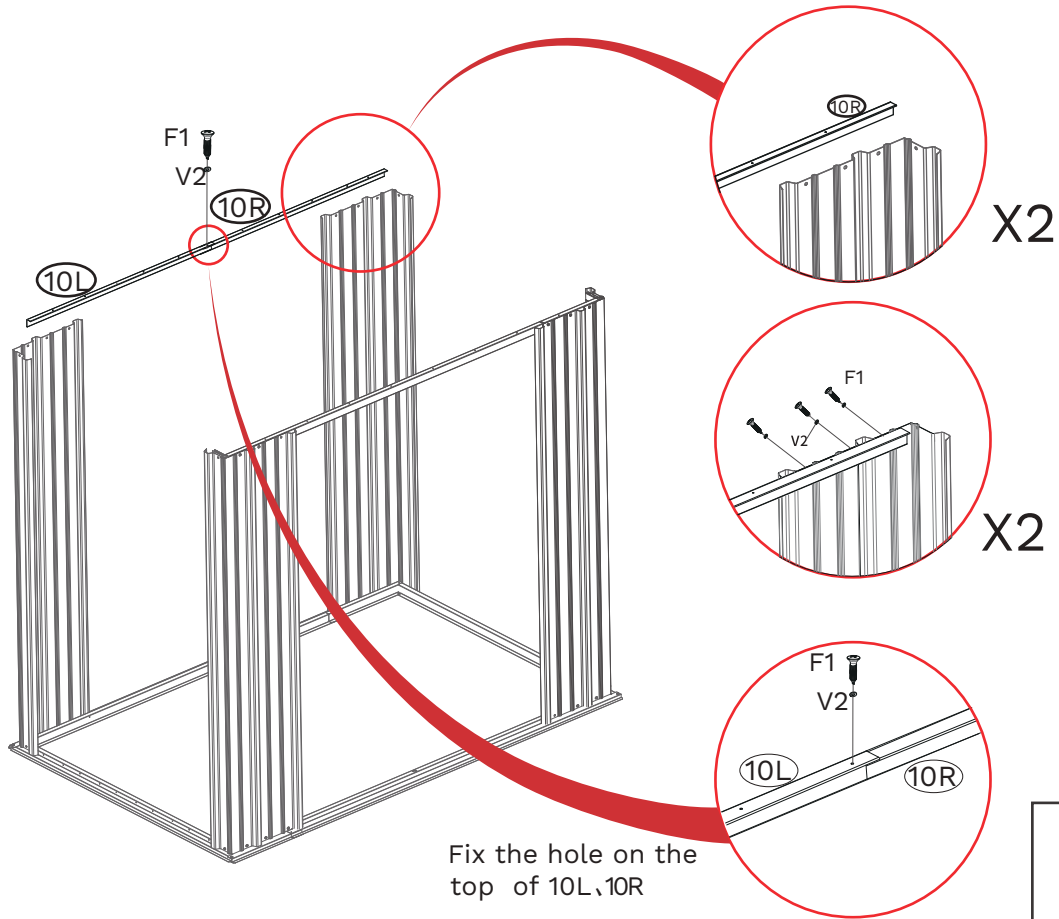

STEP 12

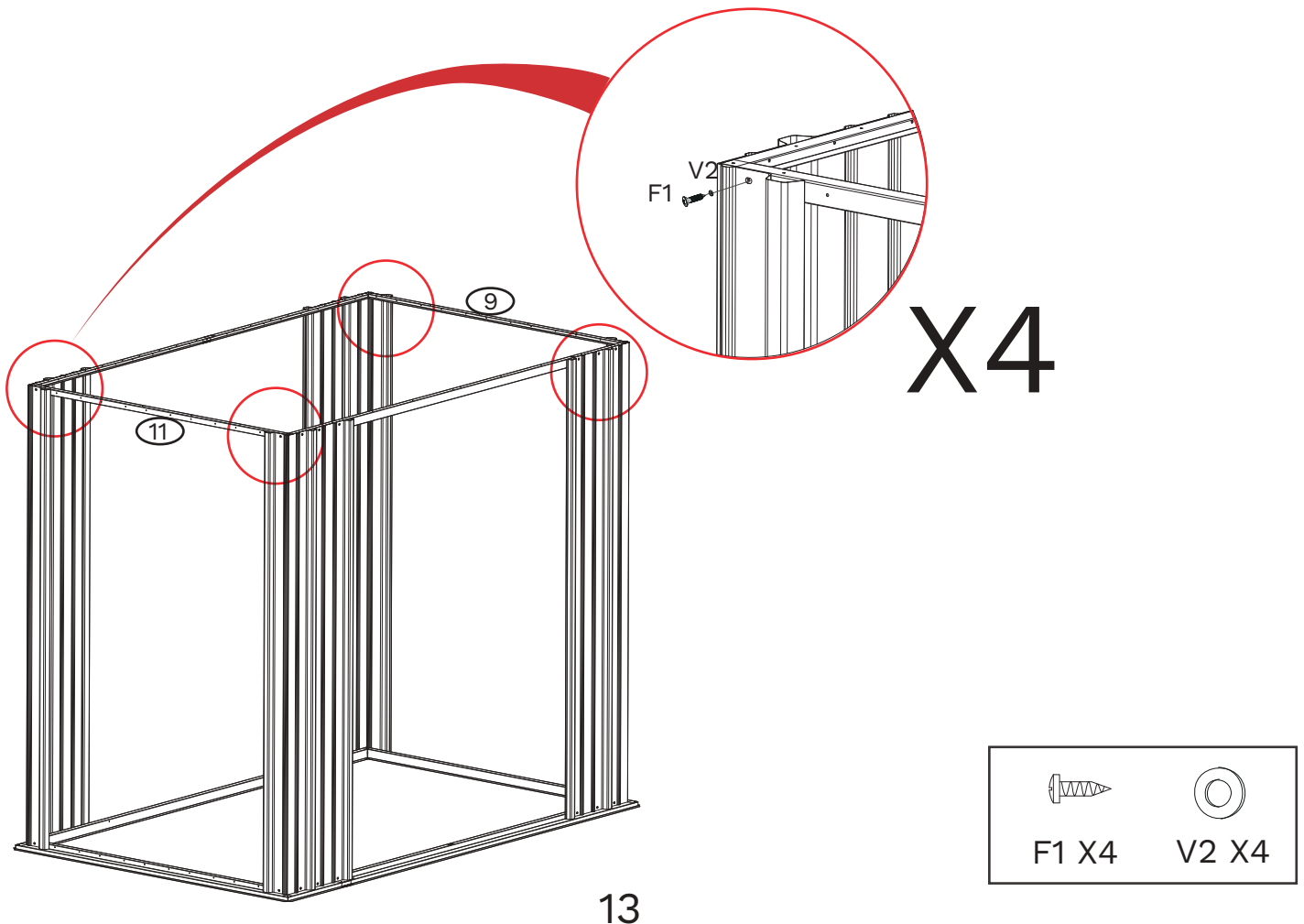

STEP 13

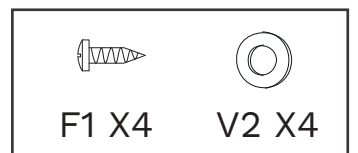
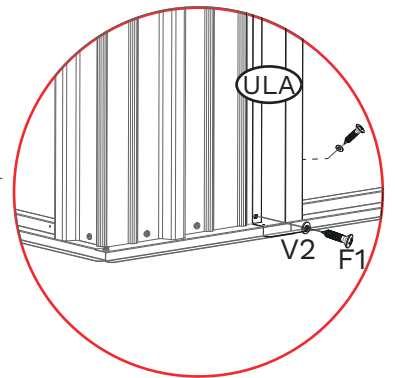
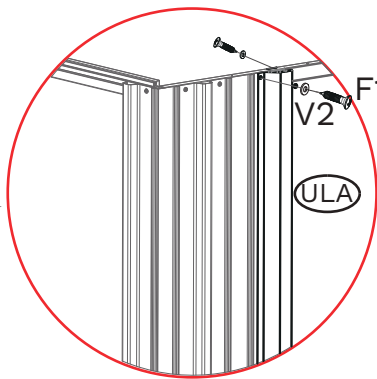
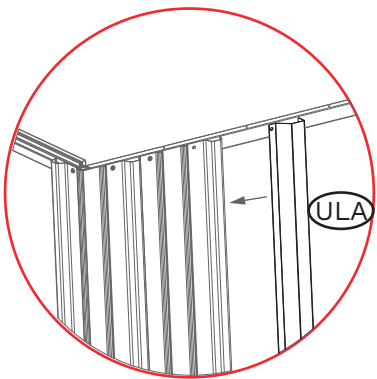
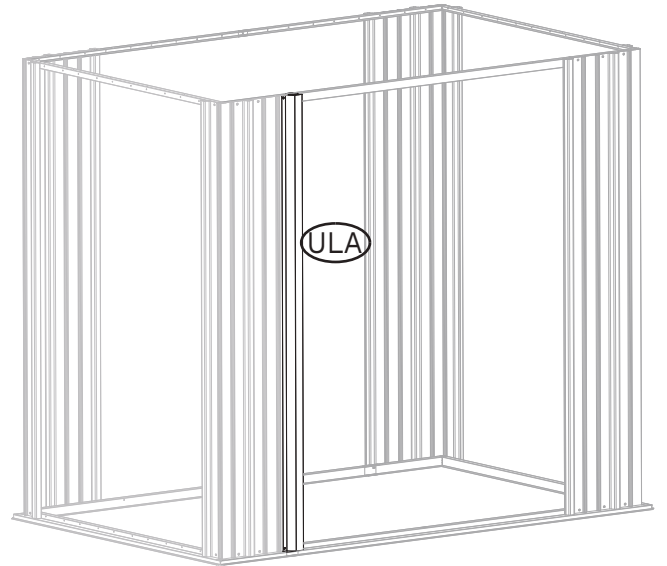
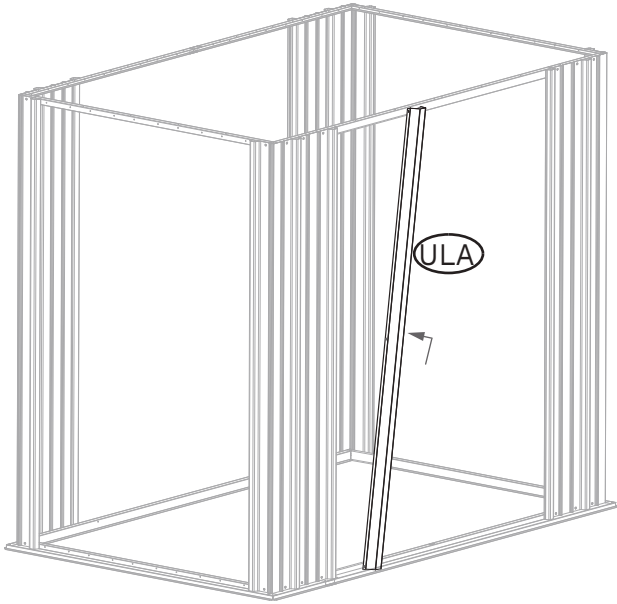

STEP 14

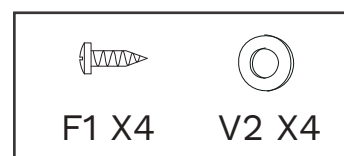
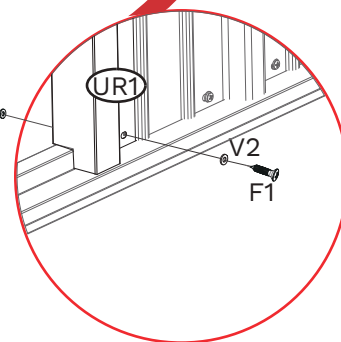
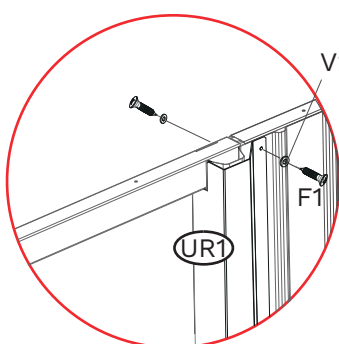
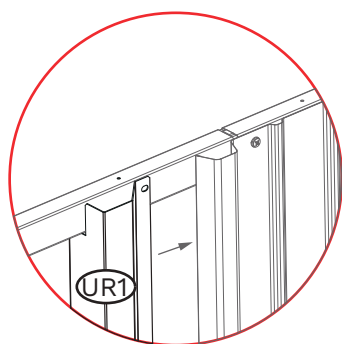
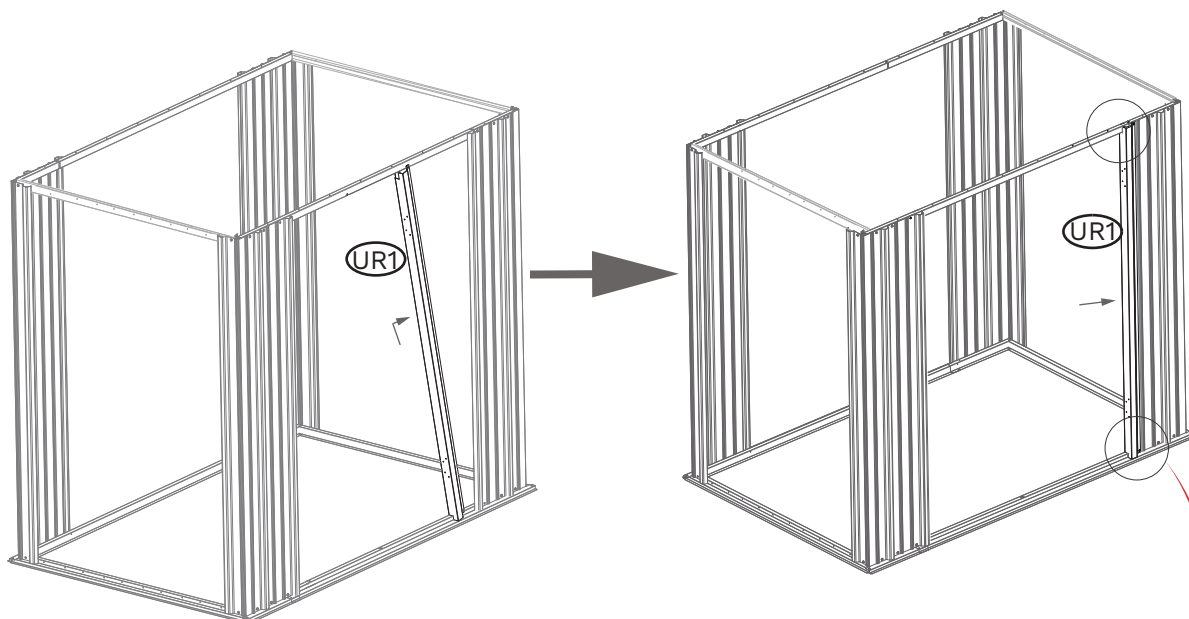

STEP 15

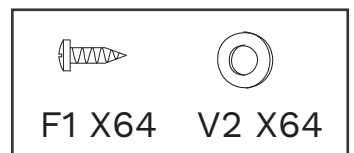
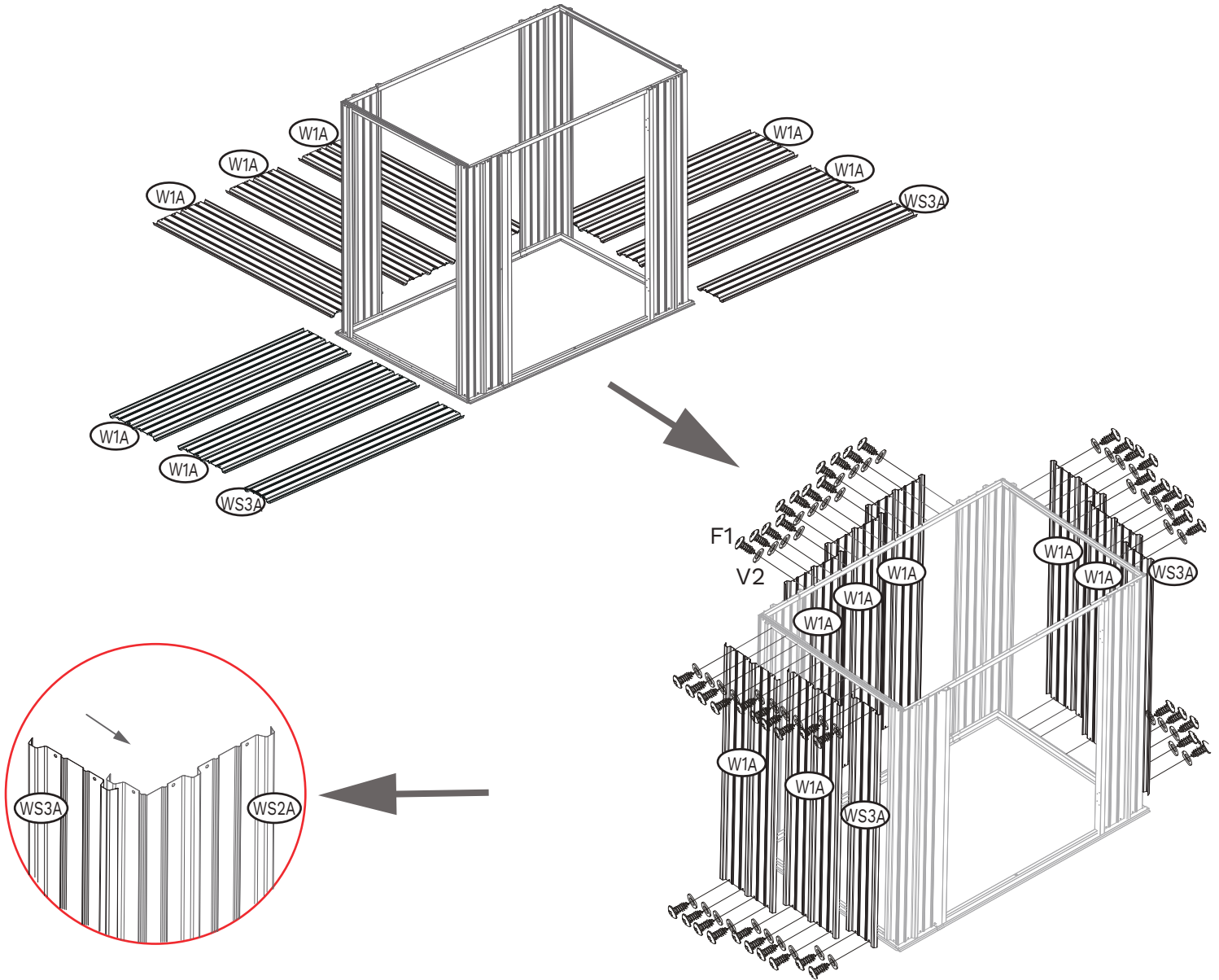

STEP 16

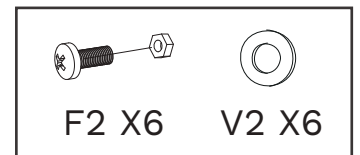
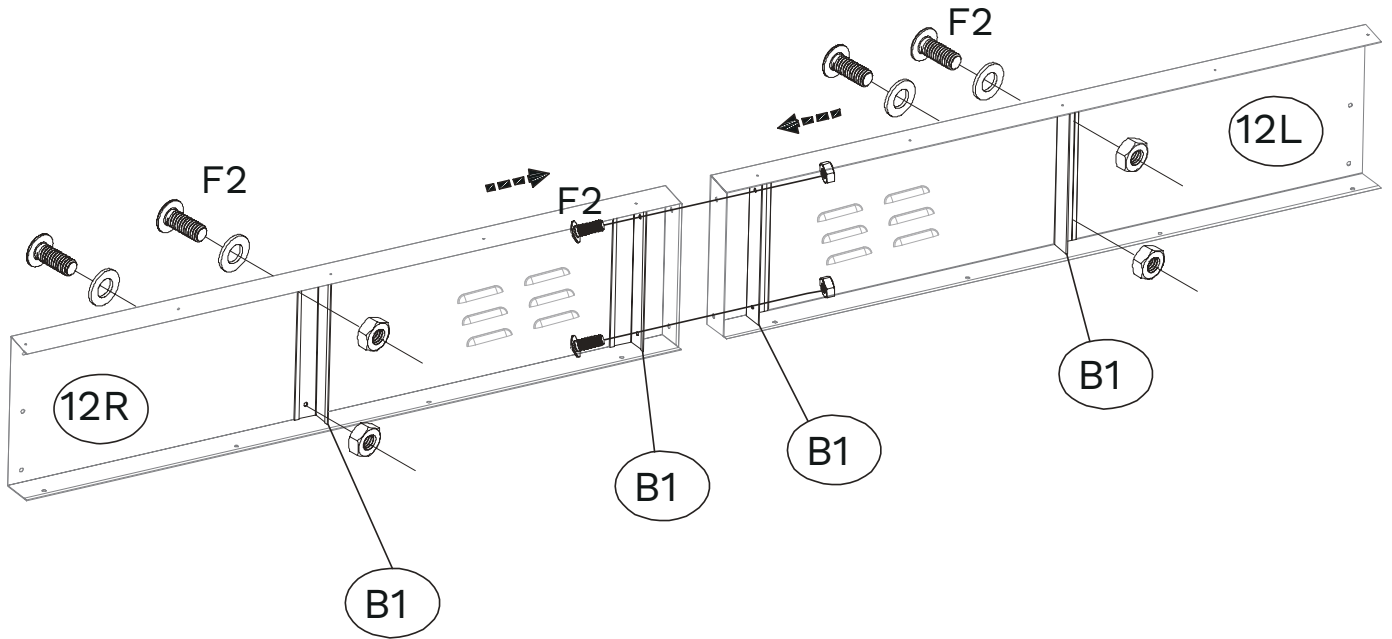

STEP 17

First, screw 12L and 12R onto the shed.
The leftmost and rightmost screws of the 12L and 12R are not fixed first.

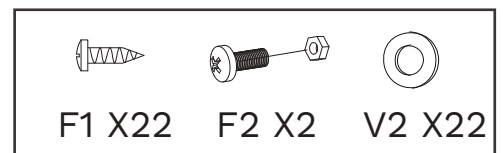
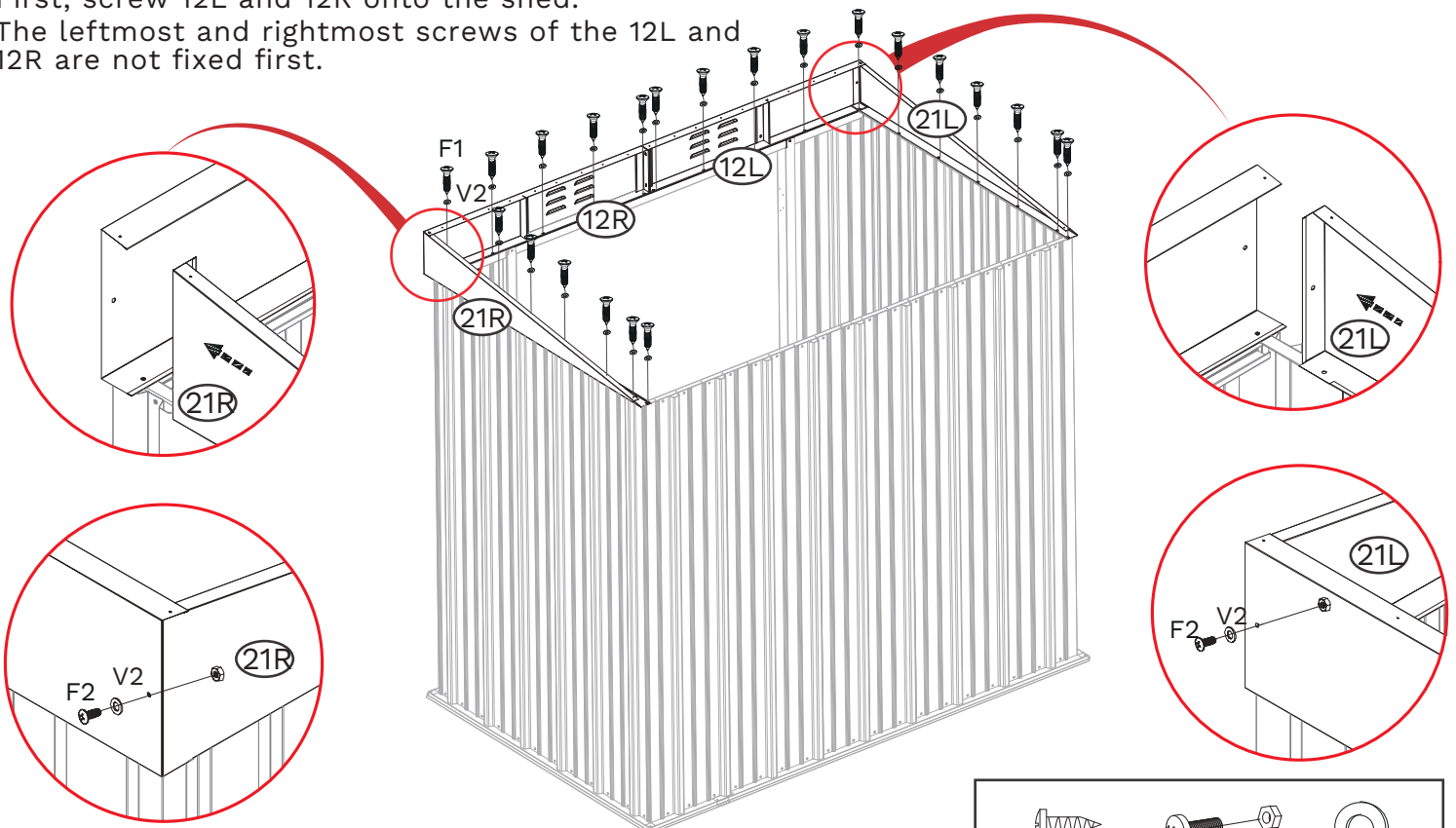

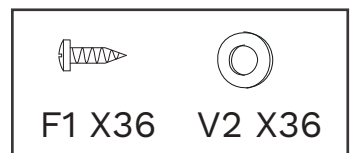
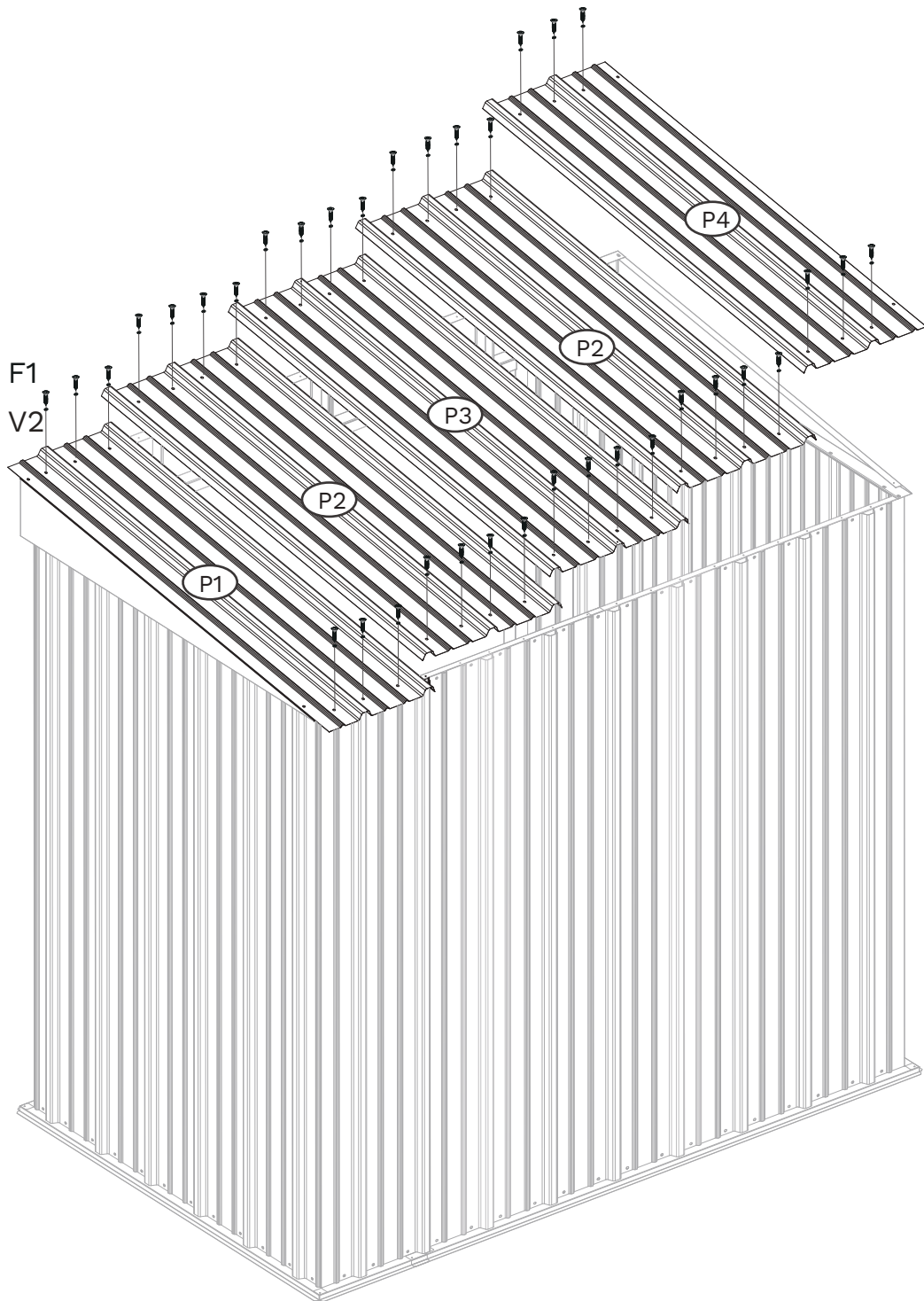

STEP 18

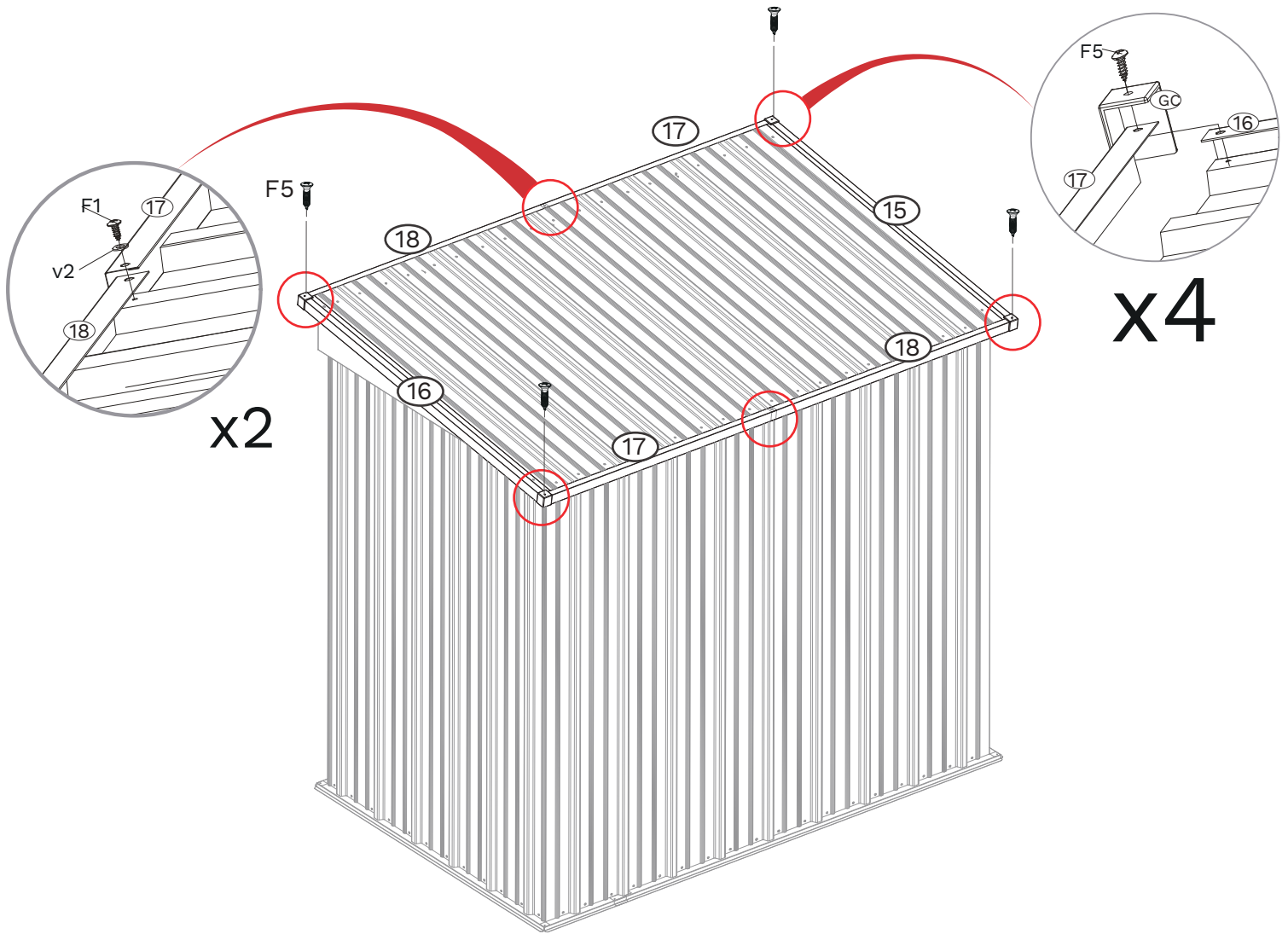

STEP 19

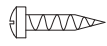

		
F1 X2	F5 X4	V2 X2

STEP 20

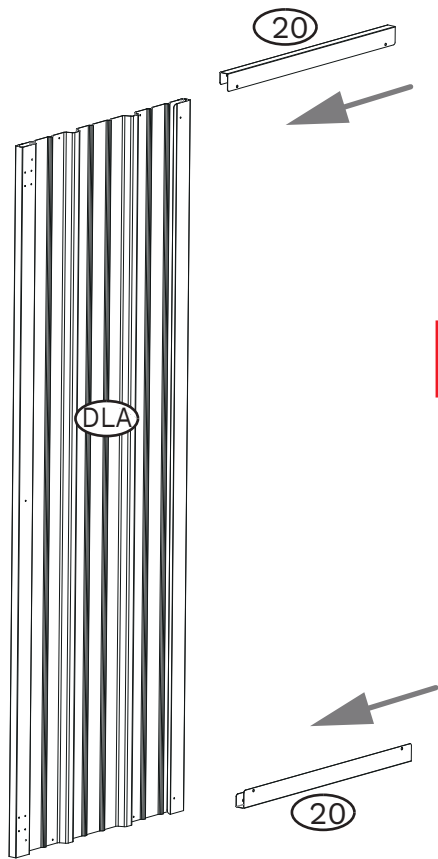

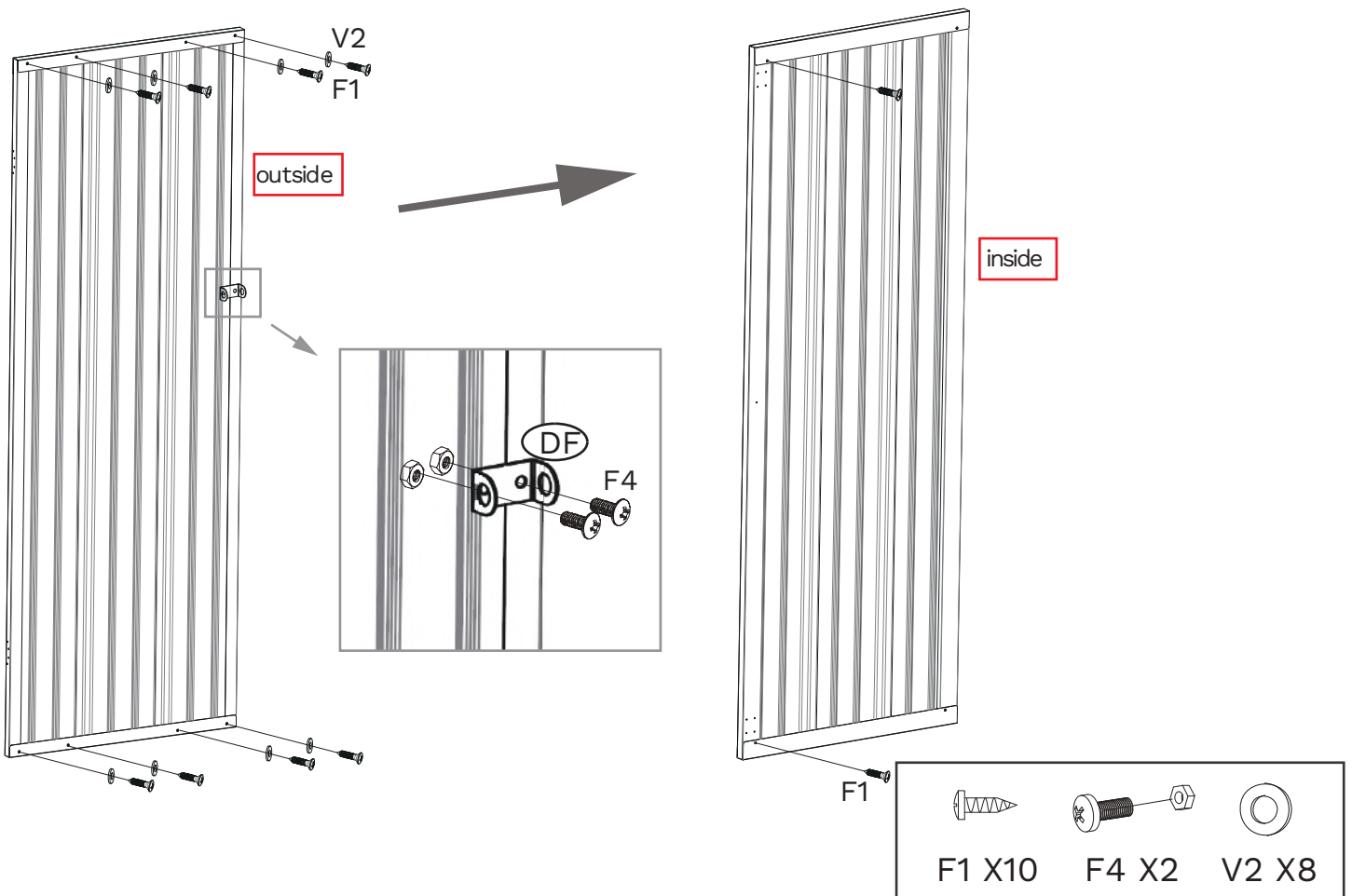

Note: make clear the front and back of the door panel.

STEP 21

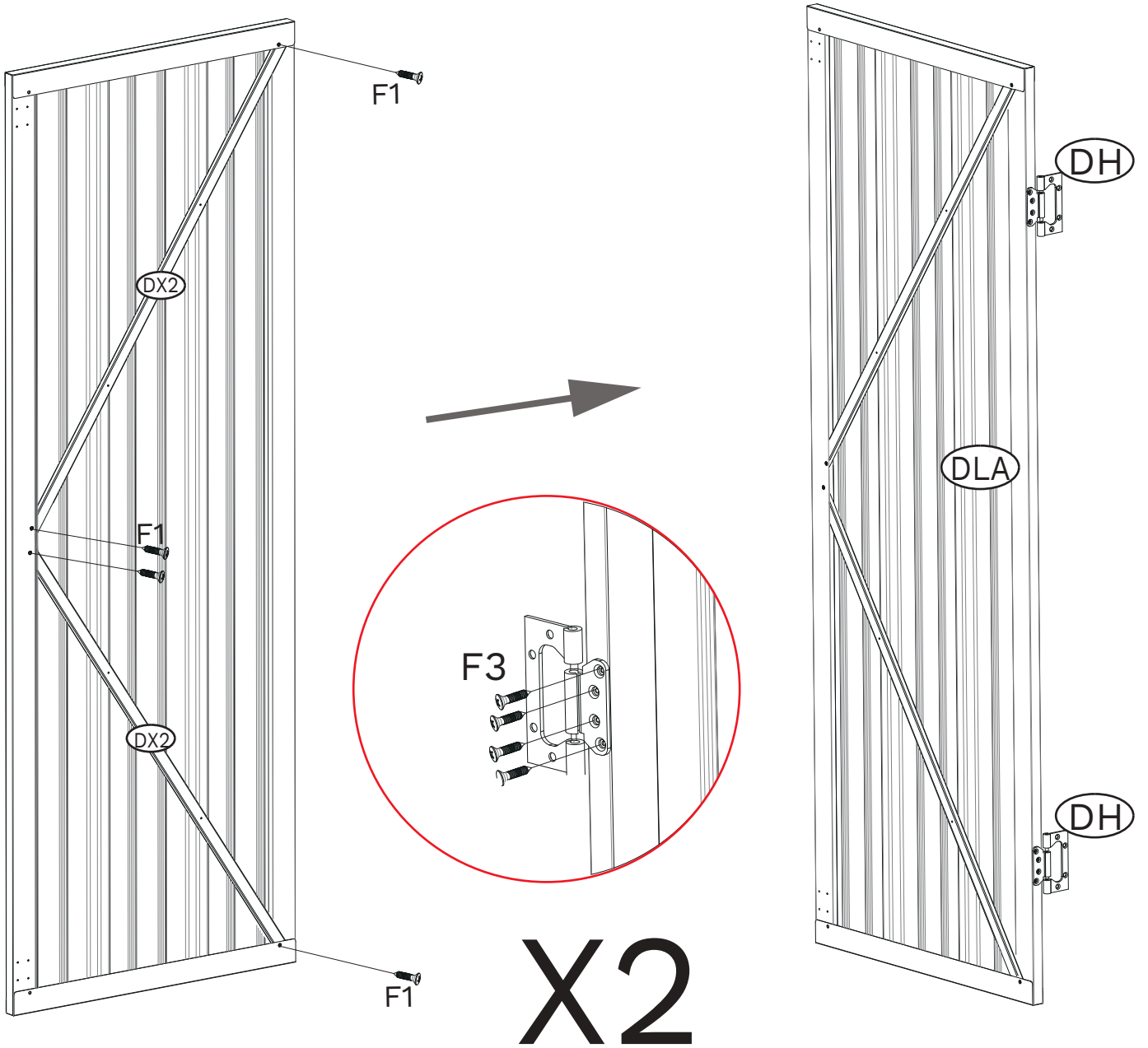

STEP 22



	
F1 X4	F3 X8

STEP 23

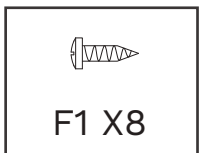
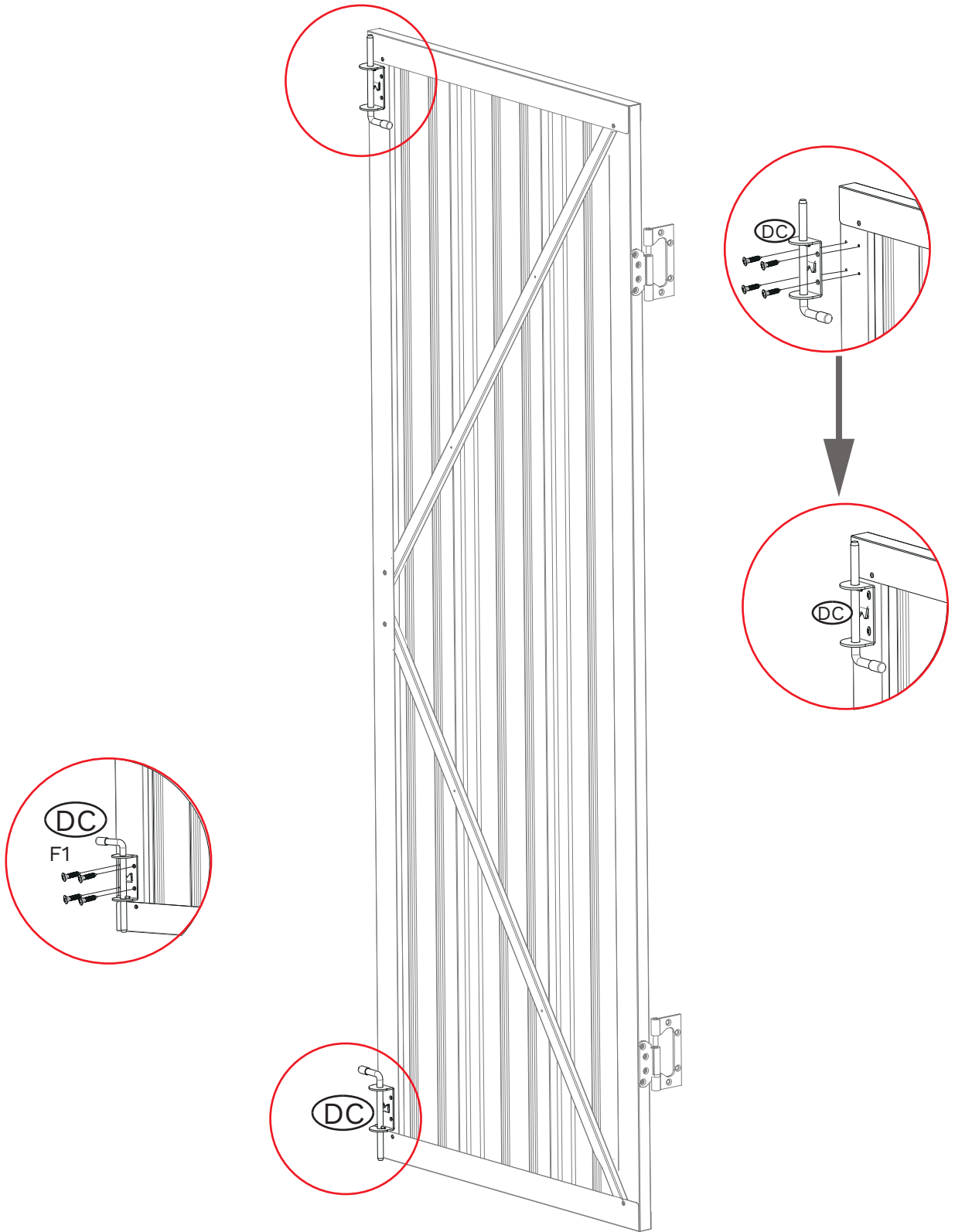

STEP 24

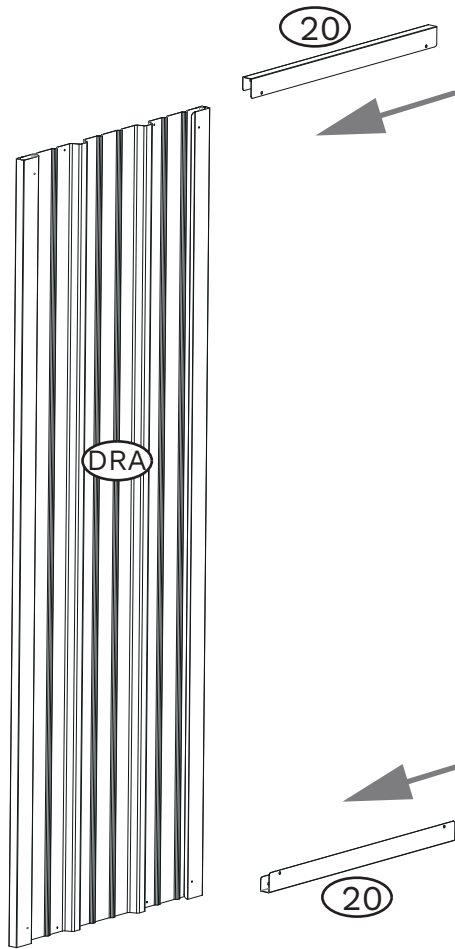

Note: make clear the front and back of the door panel

STEP 25

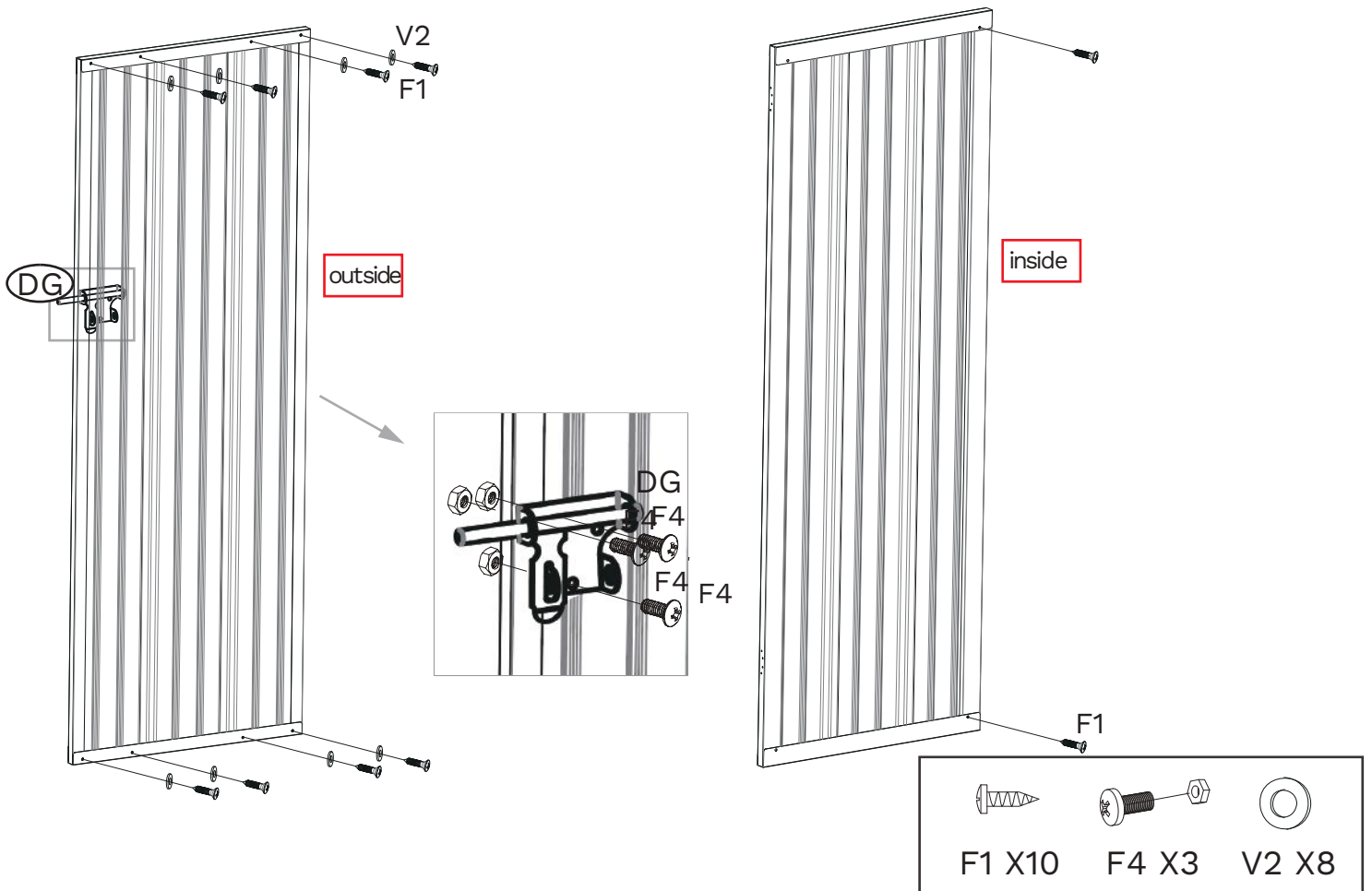

STEP 26

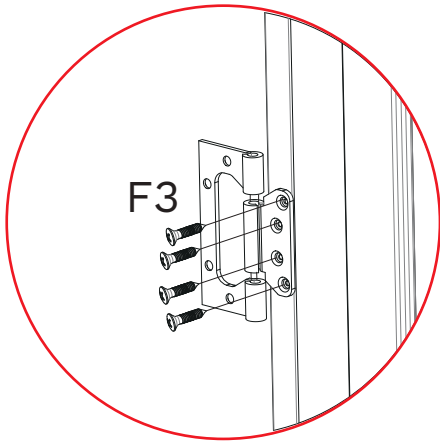

X2

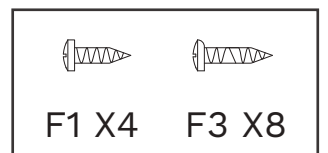
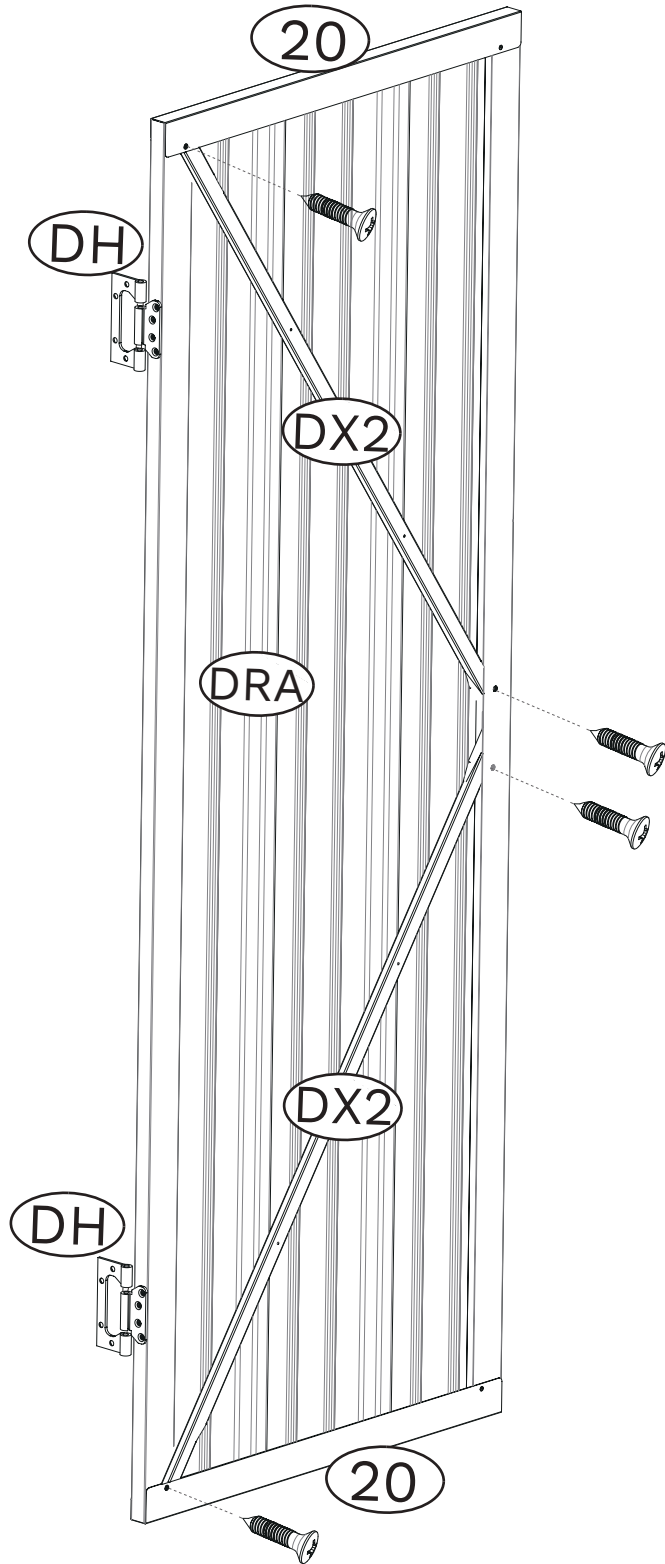

STEP 27

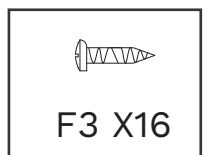
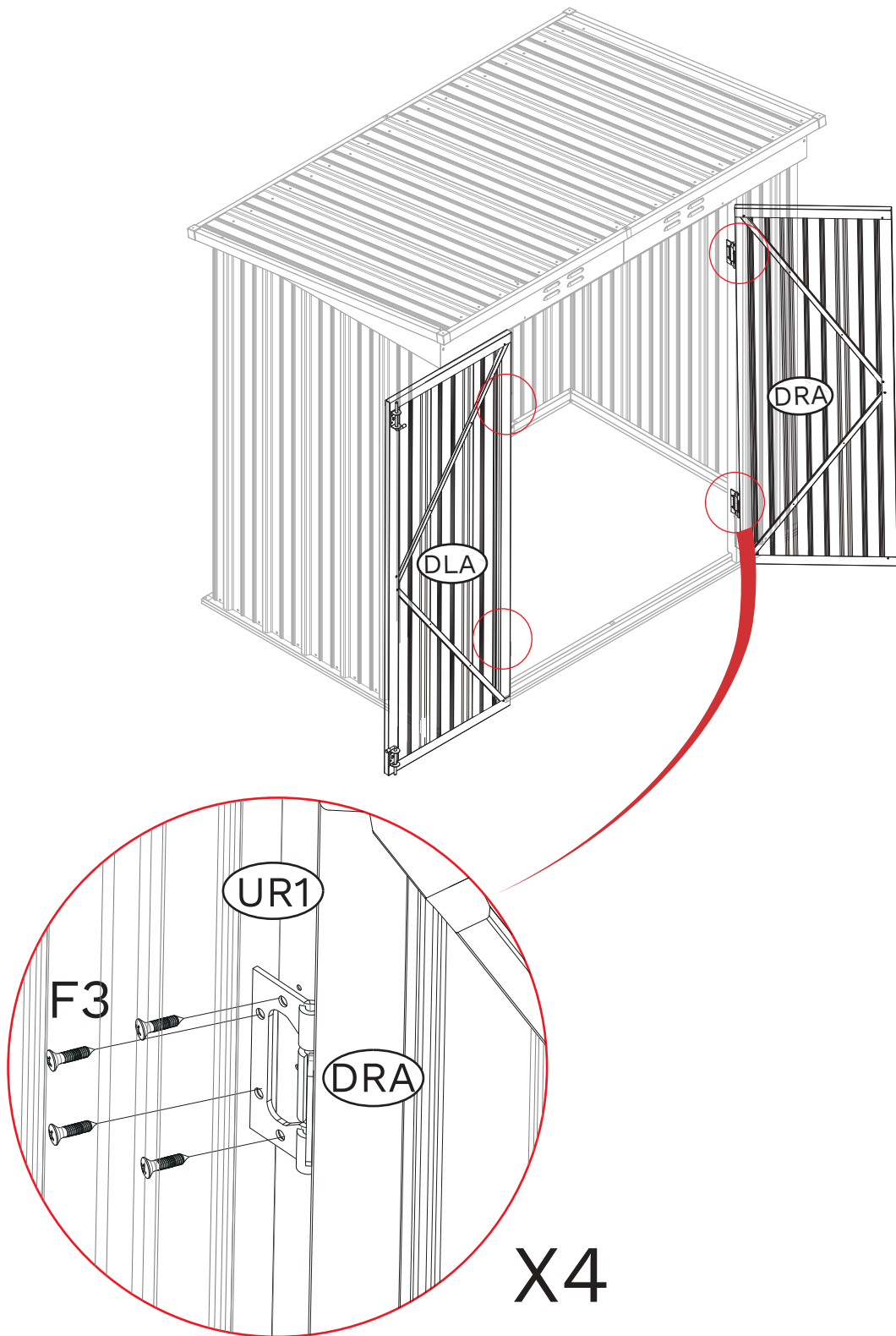

STEP 28

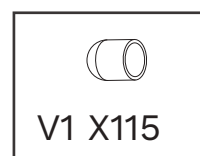
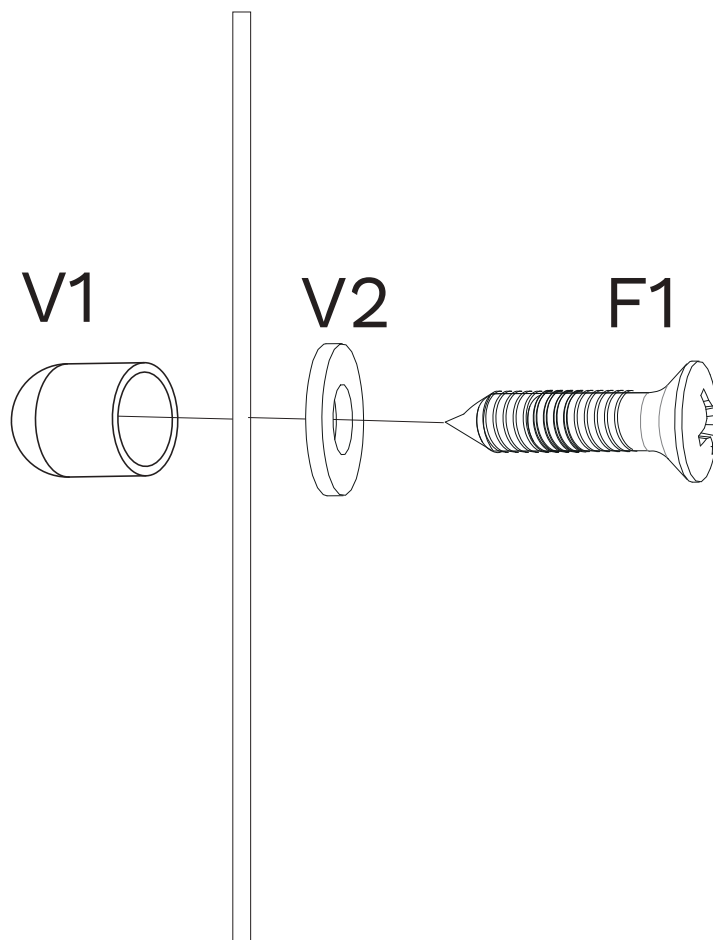

CARE & SAFETY

- Unsuitable for storage of flammable or corrosive substances.
- It is of utmost importance to assemble all of the parts according to the directions. Do not skip any step.
- Please consult your local authorities if any permits are required to erect shed.
- Periodically check shed to assure that it remains stable and that the site remains level.
- It is highly recommended to secure the shed to an immovable object or to the ground by drilling holes in the floor at the pre-marked locations and inserting proper screws into the ground (screws are not included).
- Wear safety-goggles and always follow the manufacturer's instructions when using power tools.
- Wash shed with garden hose or a mild detergent solution. Using a stiff brush or abrasive cleaner could damage shed.
- Hot items such as recently used grills, blowtorches, etc. Must not be stored in the shed.
- Heavy articles should not be leaned against the walls, as this may cause distortion.
- Keep roof clean of snow and leaves. Heavy amounts of snow on roof can damage the shed making it unsafe to enter.
- Although wind direction varies, it is an important factor when taking into account where to place your shed. Therefore, it is recommended to reduce wind exposure of the shed in general, and the door side in particular.
- Keep doors closed and locked to prevent wind damage.
- Do not stand on the roof.