

PLASTIC GARDEN SHED 5x3FT

Instructions for Assembly

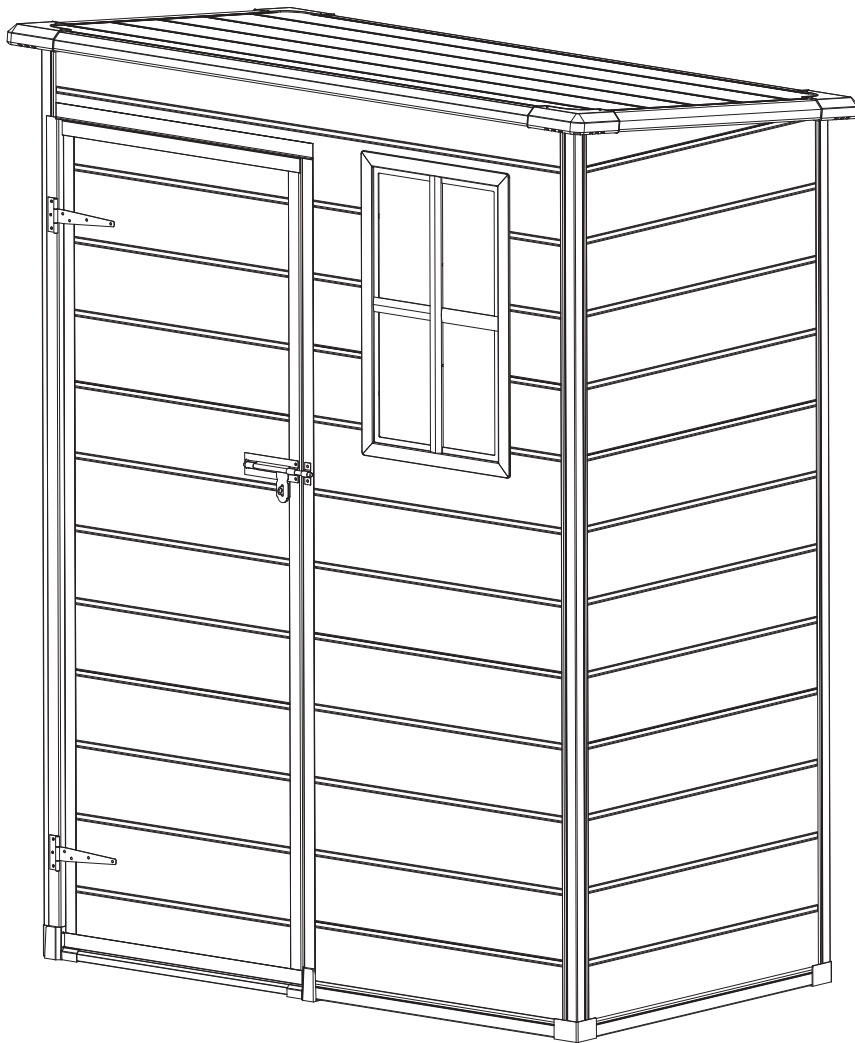

WARNING

Please read the instruction manual carefully before assembly.
Please assembly strictly in accordance with the instruction.
Please double-check to ensure that all parts of the package contents intact.
To avoid injury, work gloves are recommended during assembly.

SITE PREPARATION | PRÉPARATION DU SITE | PREPARACIÓN DEL LUGAR | VORBEREITUNG DES AUFSTELLUNGSORTES | VOORBEREIDING VAN HET TERREIN | PREPARAZIONE DEL LUOGO DI ASSEMBLAGGIO | PREPARAÇÃO DO LOCAL

Level the ground surface | Nivelez la surface du sol | Nivele la superficie del suelo | Ebenen Sie die Bodenoberfläche | Maak de bodem vlak | Livellare la superficie del terreno | Nivele a superfície do solo

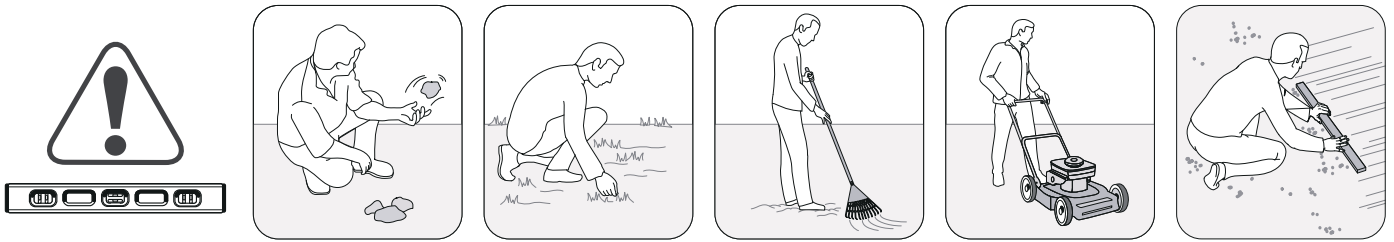

Recommendation: Construct a wooden or concrete base as a foundation | Recommandation: fabriquez une base en bois ou en béton en guise de fondation | Recomendación: construya una base de madera o de cemento a modo de cimiento | Empfehlung: Bauen Sie als Fundament eine Grundfläche aus Holz oder Beton | Aanbeveling: maak een houten of betonnen ondergrond als fundering | Raccomandazione: Costruire una base di legno o di cemento come fondamenta | Recomendação: Construa uma base de madeira ou de cimento como fundação

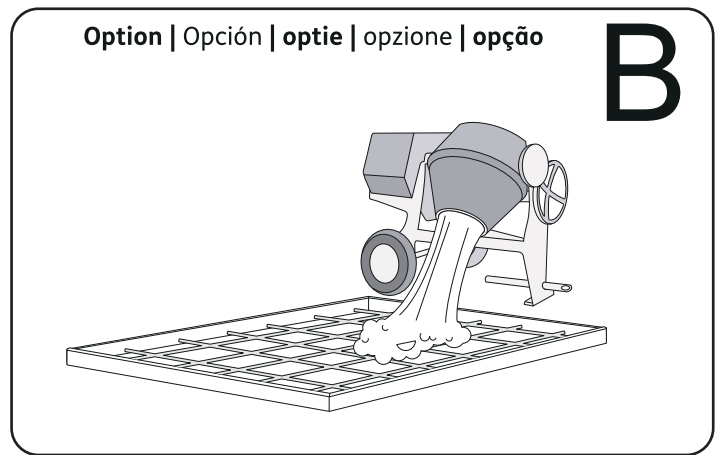
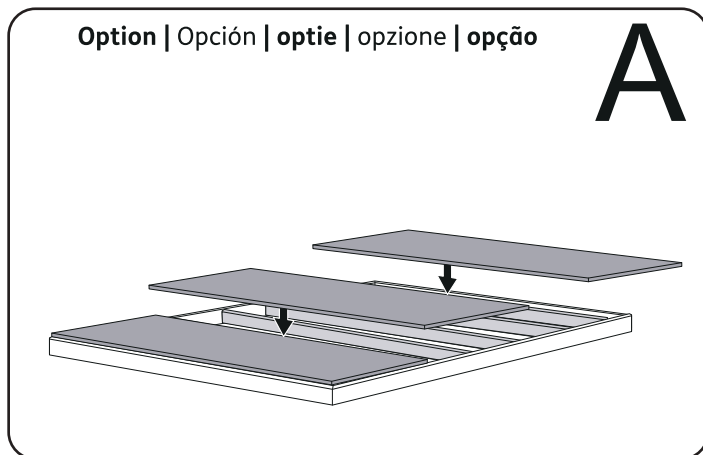

External floor measurements are: | Les mesures externes de la étage sont: | Las medidas del suelo externo son: | Die Außen-Bodenmaße betragen: | De afmetingen van de externe vloer zijn: | Le dimensioni esterne del pavimento sono: | As medidas externas do chão são:

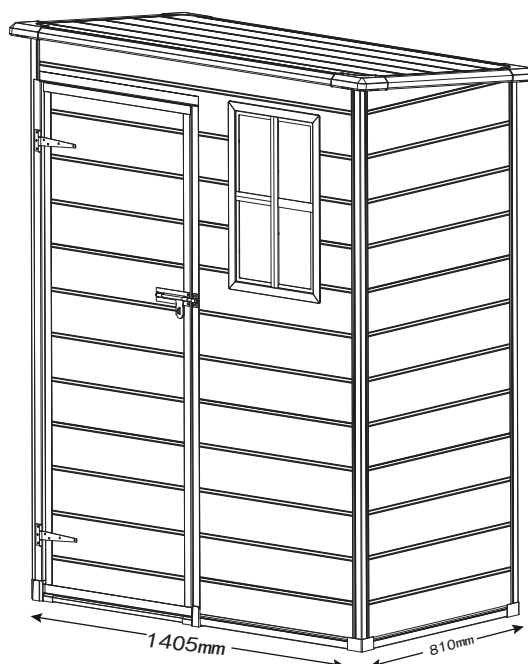

BEFORE STARTING ASSEMBLY | AVANT DE COMMENCER LE MONTAGE | ANTES DE EMPEZAR EL ARMADO | VOR MONTAGEBEGINN | VOORDAT U BEGINT TE MONTEREN | PRIMA DI INIZIARE L'ASSEMBLAGGIO | ANTES DE INICIAR A MONTAGEM

Read the care and safety guidelines at the end of this manual | Check to ensure that there are no missing or damaged parts BEFORE starting or arranging assembly | Remove all parts from the package(s) and spread them out on a clean work surface | Review all assembly instructions | Assemble all the parts according to the directions in this manual. Do not skip any steps.

Lisez les instructions de précaution et de sécurité à la fin de ce manuel | Assurez-vous qu'il n'y a pas de pièces manquantes ou endommagées AVANT de commencer ou d'organiser l'assemblage | Retirez toutes les pièces du/des paquet(s) et étalez-les sur une surface de travail propre | Lisez toutes les instructions de montage | Assemblez toutes les pièces selon les instructions de ce manuel. Ne sautez aucune étape.

Lea las instrucciones de precauciones y seguridad que están al final de este manual | Asegúrese de que no faltan piezas ni están dañadas ANTES de comenzar o disponer el montaje | Saque todas las piezas del paquete o paquetes y póngalas sobre una superficie de trabajo limpia | Revise todas las instrucciones de montaje | Monte todas las piezas según las instrucciones de este manual. No se saltee ningún paso.

Lesen Sie die Sicherheitsrichtlinien am Ende des Benutzerhandbuchs durch | Prüfen Sie bitte VOR dem Zusammenbau, dass keine Teile beschädigt sind oder fehlen | Nehmen Sie alle Teile aus der Verpackung und breiten Sie sie auf einer sauberen Arbeitsfläche aus | Gehen Sie noch einmal die komplette Aufbauanleitung durch | Bauen Sie alle Teile entsprechend der Anleitung in diesem Handbuch zusammen. Lassen Sie dabei keinen Arbeitsschritt aus.

Lees de richtlijnen voor zorg en veiligheid achterin deze handleiding | Controleer dat er geen onderdelen mankeren, of beschadigd zijn, VOORDAT u met de montage begint | Haal alle onderdelen uit het pakket (of uit de pakketten) en leg ze opeen schoon werkoppervlak | Bekijk alle montagehandleidingen | Monteer alle onderdelen volgens de aanwijzingen van deze handleiding. Sla geen stappen over.

Leggere le linee guida di assistenza e sicurezza alla fine di questo manuale | Assicurarsi che non ci siano parti mancanti o danneggiate PRIMA di iniziare l'assemblaggio | Estrarre tutti i componenti dall'imballo e posizzarli su una superficie di lavoro pulita | Consultare tutte le istruzioni di montaggio | Assemblare tutti i componenti secondo le istruzioni contenute nel manuale. Non saltare nessuna fase.

Leia as diretrizes de cuidados e segurança que constam da parte final deste manual | Verifique para se assegurar de que não há peças em falta ou danificadas ANTES de começar a preparar a montagem | Retire todas as peças da embalagem e espalhe-as numa superfície de trabalho limpa | Reveja todas as instruções de montagem | Monte todas as peças de acordo com as instruções do manual. Não salte quaisquer passos.

REQUIRED TOOLS | OUTILS EXIGÉS | HERRAMIENTAS NECESARIAS | BENÖTIGTE WERKZEUGE | BENODIGD GEREEDSCHAP | ATTREZZATURA OCCORRENTE | FERRAMENTAS NECESSÁRIAS



SPATULA | SPATULE | ESPÁTULA | SPACHTEL | SPATEL | SPATOLA | ESPÁTULA

- Use spatula (part "SG8") for easier insertion of panel into profile.
- Utilisez la spatule (partie "SG8") pour une meilleure insertion du panneau dans le profil.
- Utilice una espátula (pieza "SG8") para una mejor inserción del panel en el perfil.
- Benutzen Sie den Spachtel (Bezeichnung "SG8"), um die Platten leichter in die Nut einführen zu können.
- Gebruik spatel (onderdeel SG8) voor het gemakkelijk invoeren van het paneel in het profiel.
- Utilizzare la spatola (parte SG8) per inserire il pannello più facilmente nel profilo.
- Utilize uma espátula (peça "SG8") para facilitar a inserção do painel no perfil.

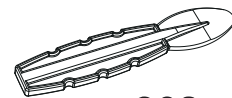





















































SG8 x2



ASSEMBLY REQUIRES TWO PEOPLE | LE MONTAGE DOIT ÊTRE EFFECTUÉ PAR DEUX PERSONNES | SE NECESITAN DOS PERSONAS PARA ARMARLO | ZWEI PERSONEN ZUR MONTAGE NOTWENDIG | MONTAGE VEREIST TWEE PERSONEN | L'ASSEMBLAGGIO RICHIEDE DUE PERSONE | A MONTAGEM EXIGE DUAS PESSOAS

PARTS LIST

NO.	PART.	Qty.
AW1-1		6
AW1-2		1
AW1-3		1
AW2-1		1
AW2-2		1
AW2-3		1
AW3-1		3
AW3-3		1
AD1-1		1
AD1-2		1
AD1-3		1
AR1-1		1
SG12		1
AP1		1
AP2		2
AP3		2
AP4		1
AP5		1
AA3		1
AA1R		1
AAP1		1
AA2R		1
AA2L		1
AA4		1
AS1		1
AR1-2		1
AF1-2		1

NO.	PART.	Qty.
AF1-1		1
SG10		1
SG101		1
M01		2
M03-6R		1
M03-7		1
M04		1
SG8		2
SG9		3
Drill		1
Z410		53
Z420		106
ZW413		18
AP7		1
AP8		2
AP9		2
SG7-2		1
SG7-3		1
SG11		1
SG2		4
SG6		3
SG102		2
SG103		2
SG14		2
SG15		2
AS2		1

- Use spatula  (part "SG8") for easier insertion of panel into profile
- Please ensure the panels are all installed on position before screwing



Floor Assembly

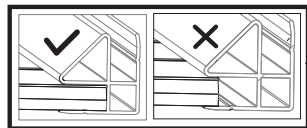

- Fully fit the panel inside the profile

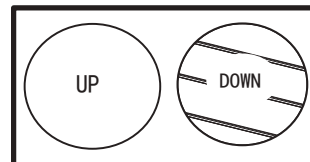

- Note: The crease line of the floor must be underneath

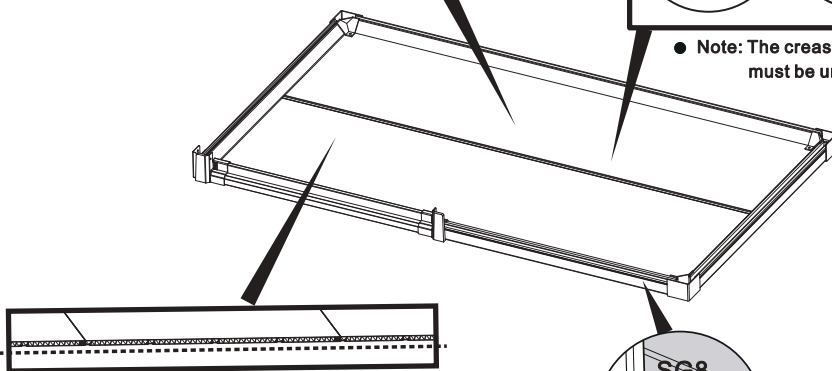

- The floor panels must be straight

- Use spatula  (part "SG8") for easier insertion of panel into profile

Step 1

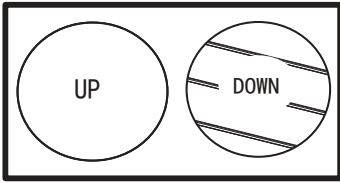

● Grain should be down

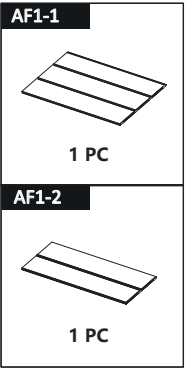
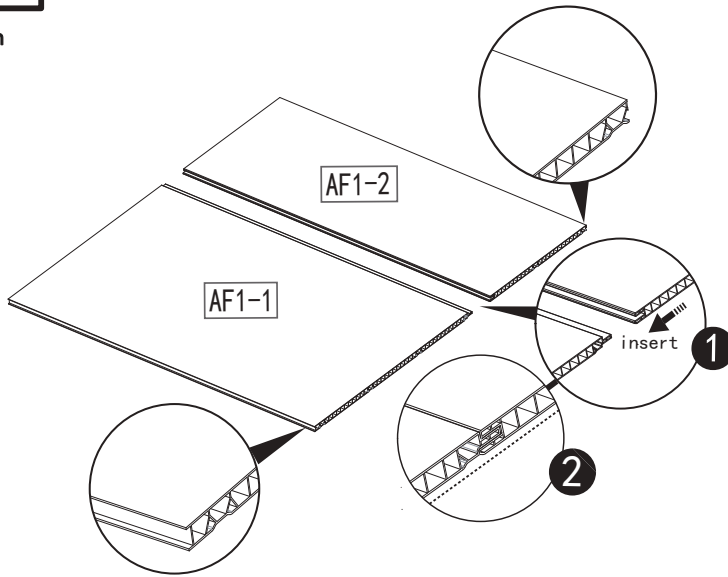



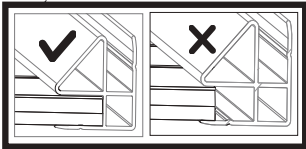

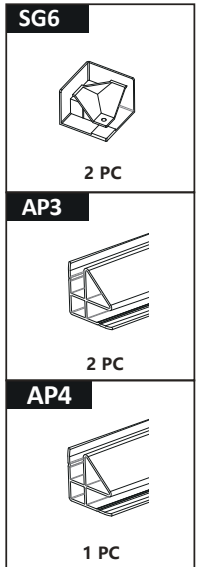
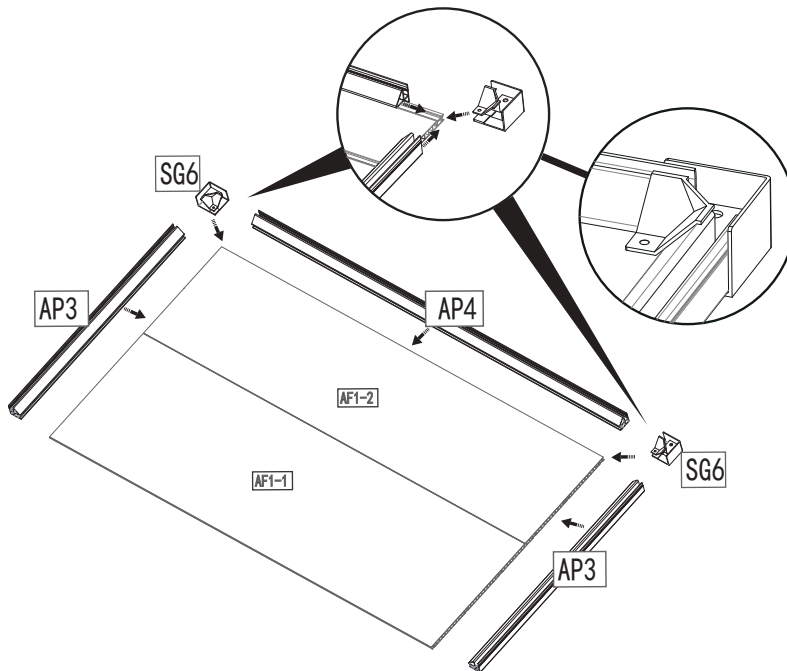

Step 2



● Fully fit the panel inside the profile



Step 3

SG6  1 PC	AP5  1 PC
SG7-2  1 PC	AP7  1 PC
SG7-3  1 PC	
	

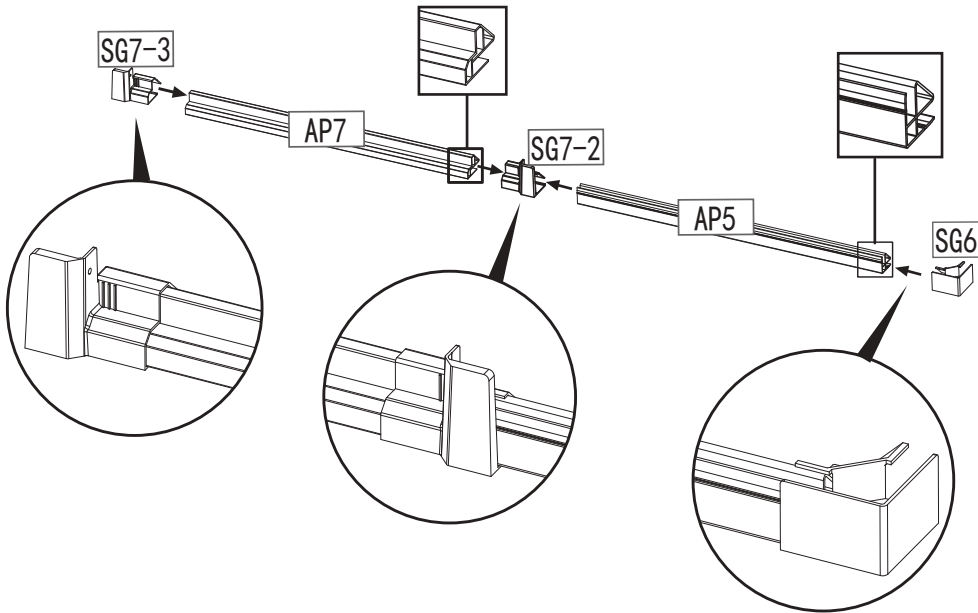

Step 4

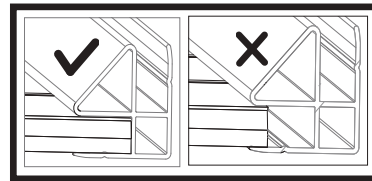

● Fully fit the panel inside the profile

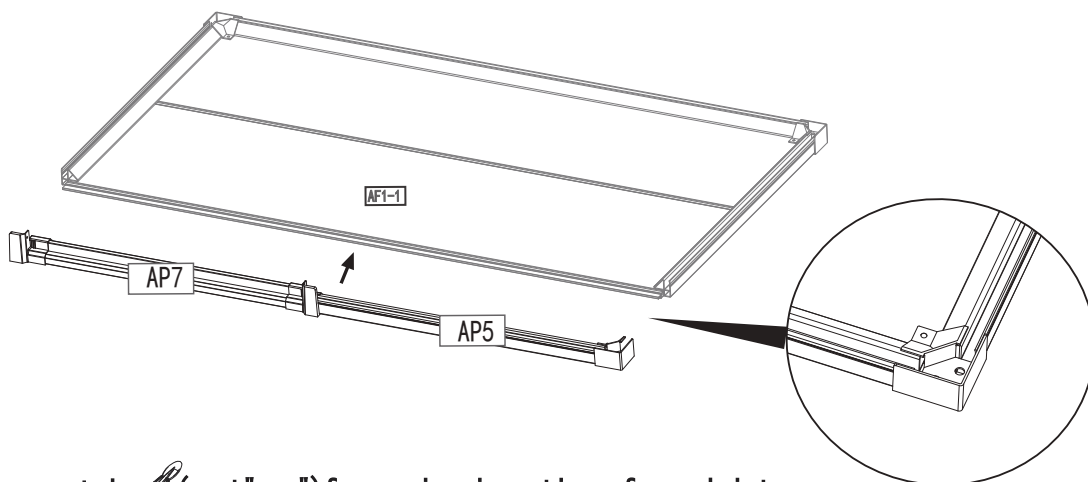
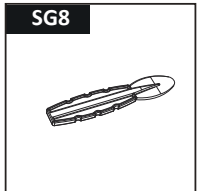

● Use spatula  (part "SG8") for easier insertion of panel into profile

Step 5

Z410



3 PC

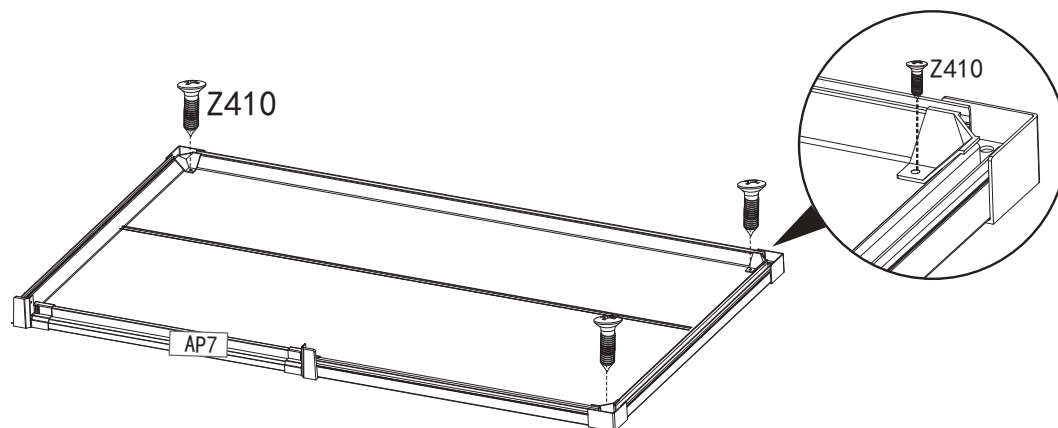
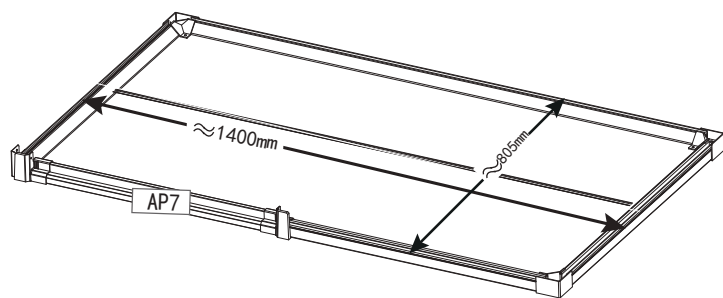

Step 6

● Turn over the floor panel

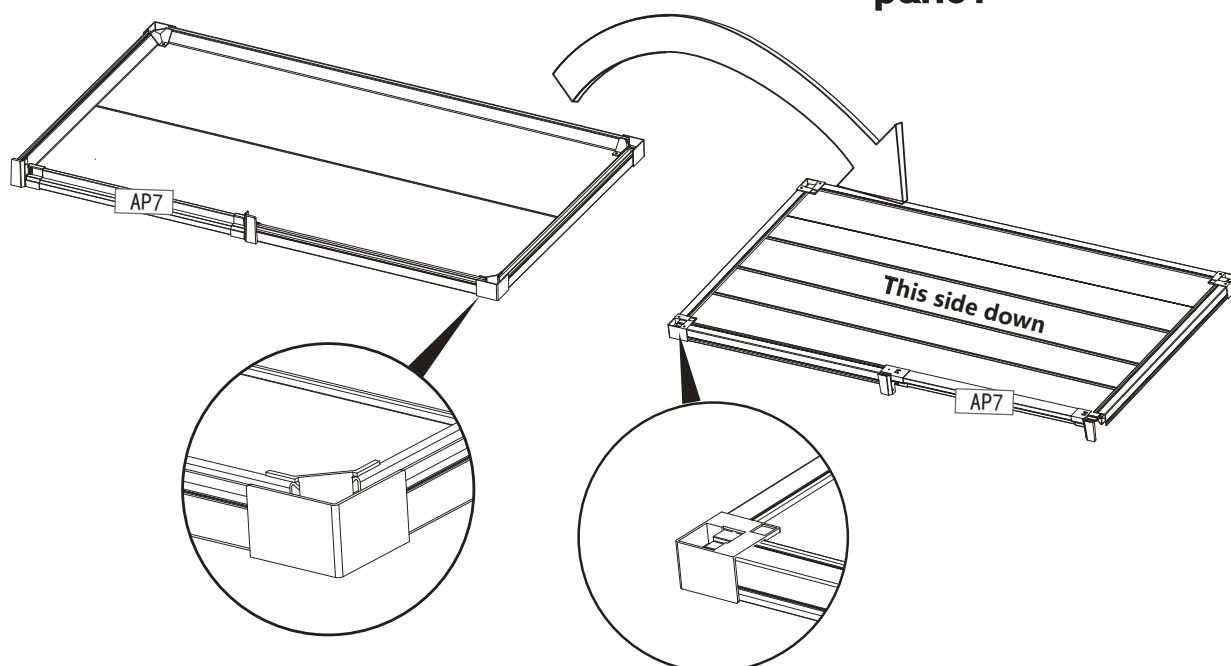

Step 7

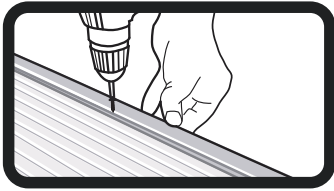

● Nail along the marked line on profile

Caution:

Please use Drill  to predrill a hole at depth 1mm before screw.



Z420



8 PC

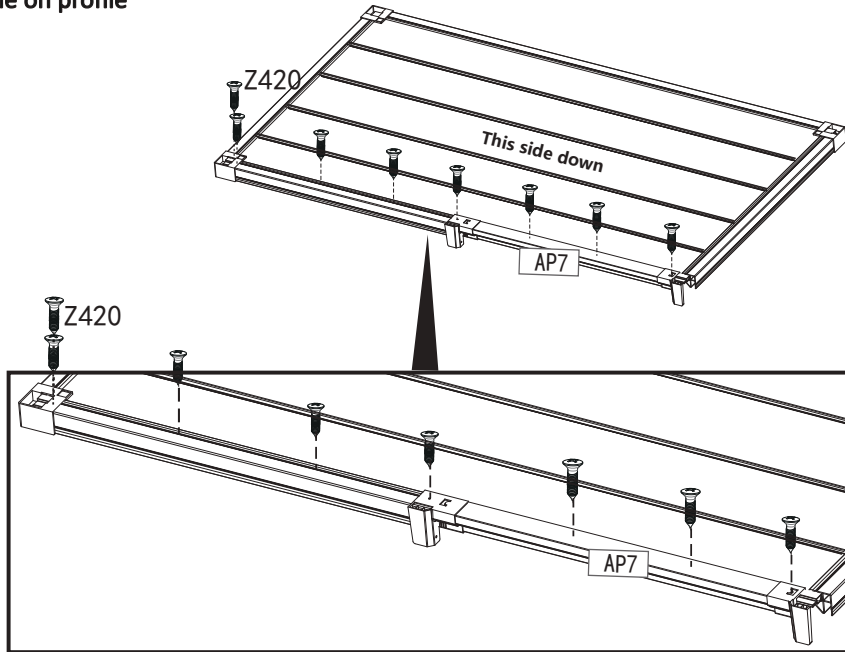

Step 8

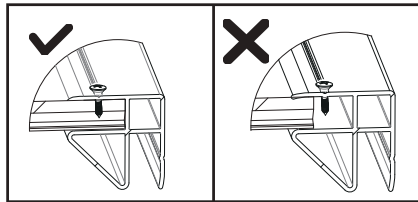

● Fully fit the panel inside the profile;
then screw on mark line

Caution:

Please use Drill  to predrill a hole at depth 1mm before screw.

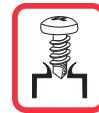

Z420



11 PC

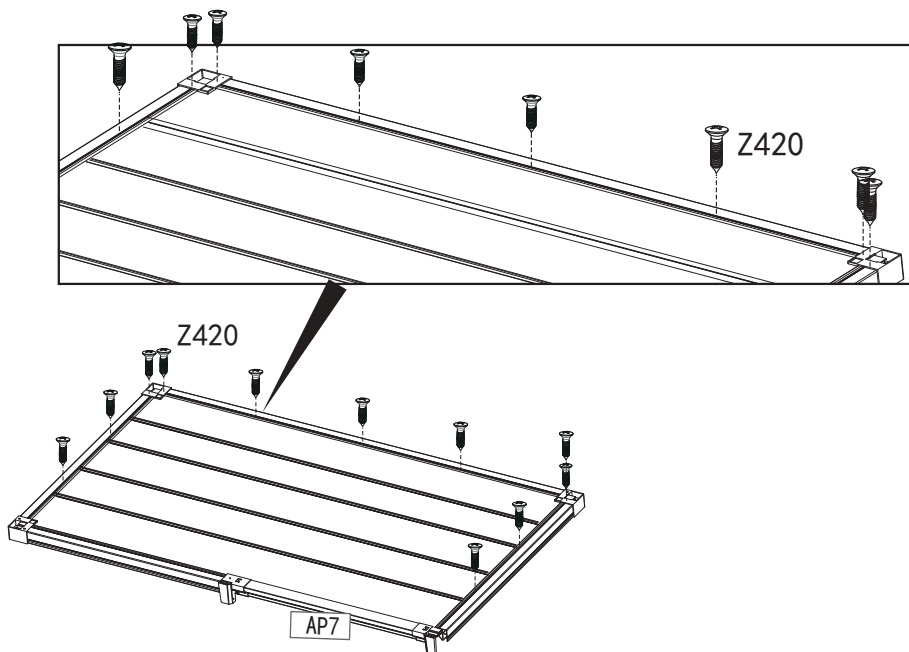

Step 9

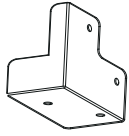
Z420	SG11
	
2 PC	1 PC

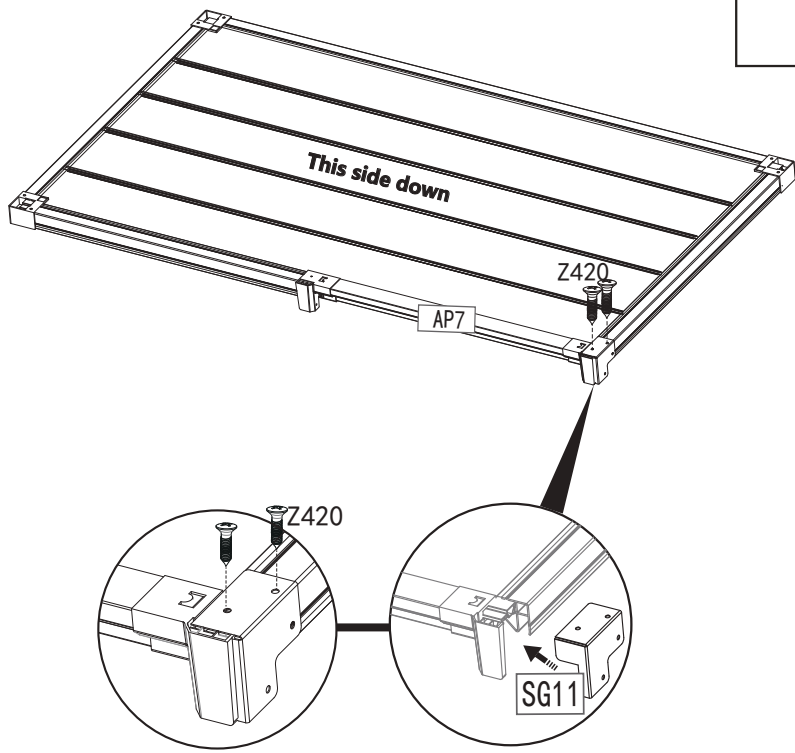

Step 10

● Turn over the floor panel

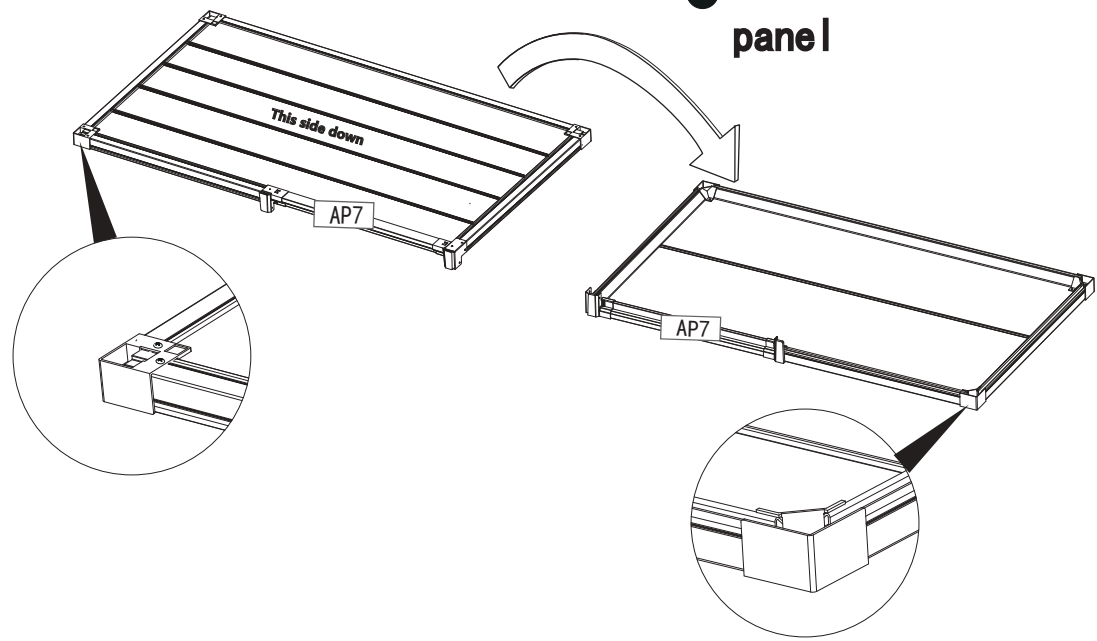

Wall Assembly

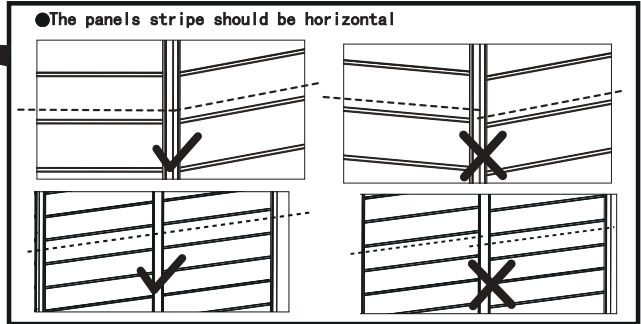
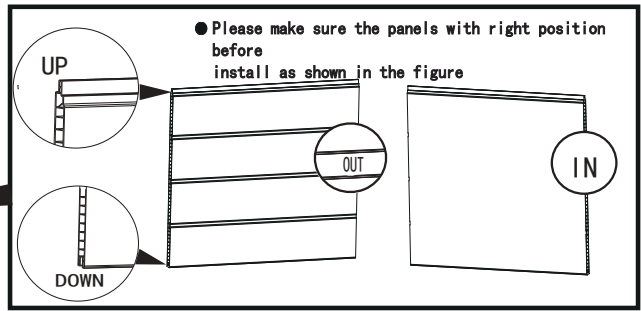
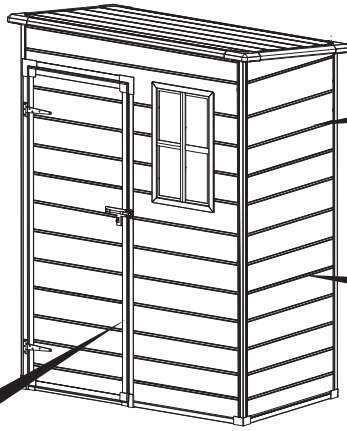

● Use spatula (part "SG8") for easier insertion of panel into profile

Step 11

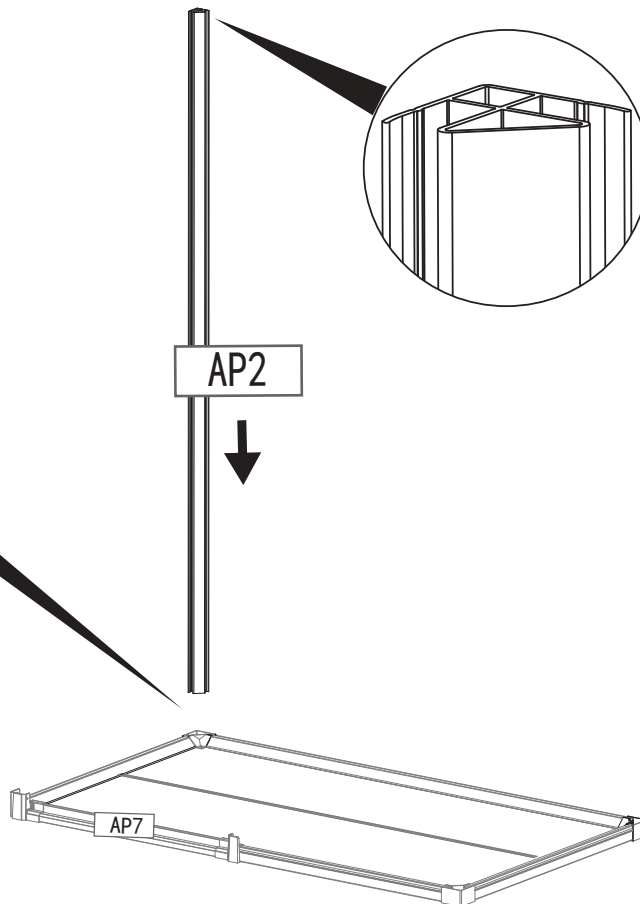
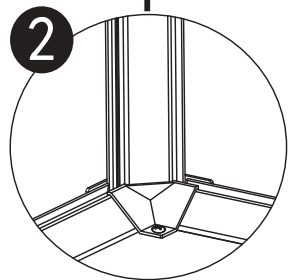
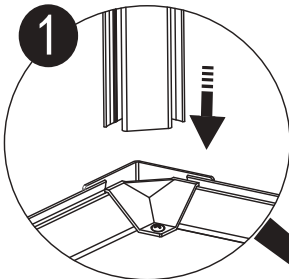
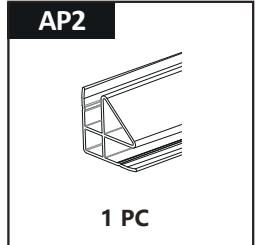

Step 12

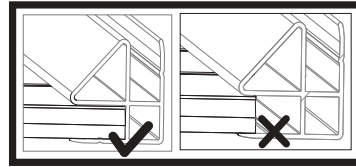

● Fully fit the panel inside the profile

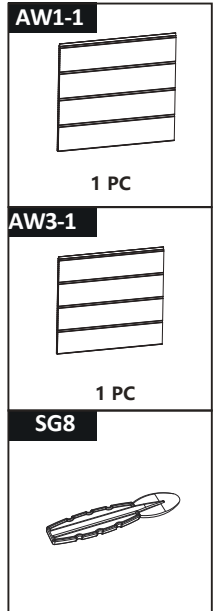
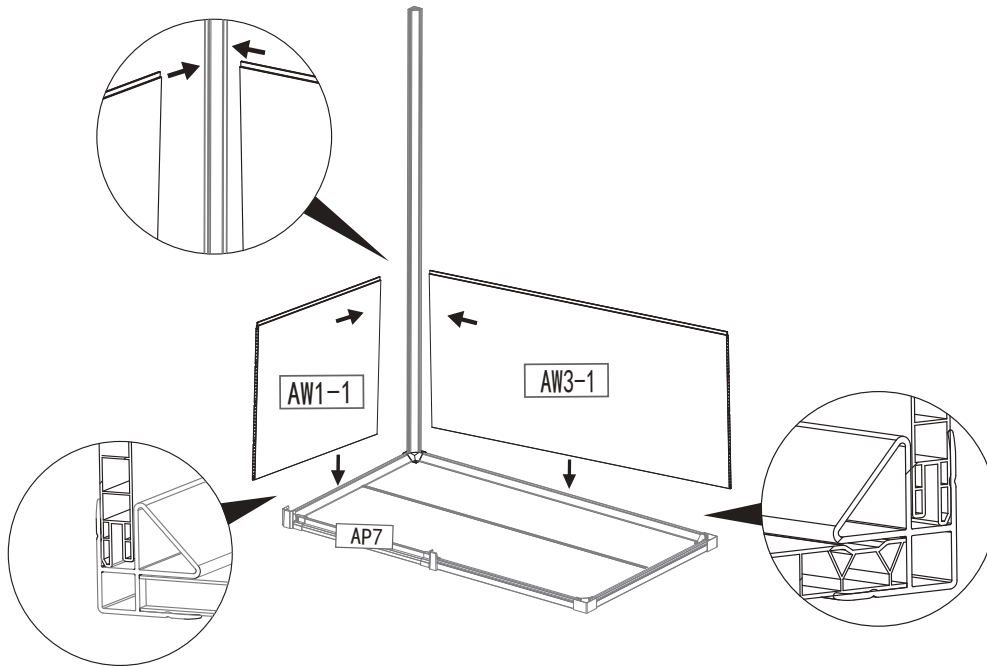

Step 13

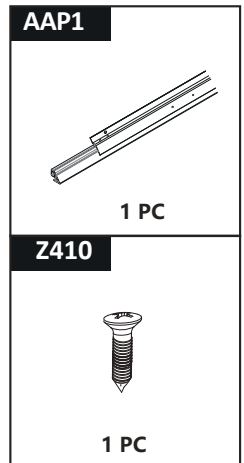
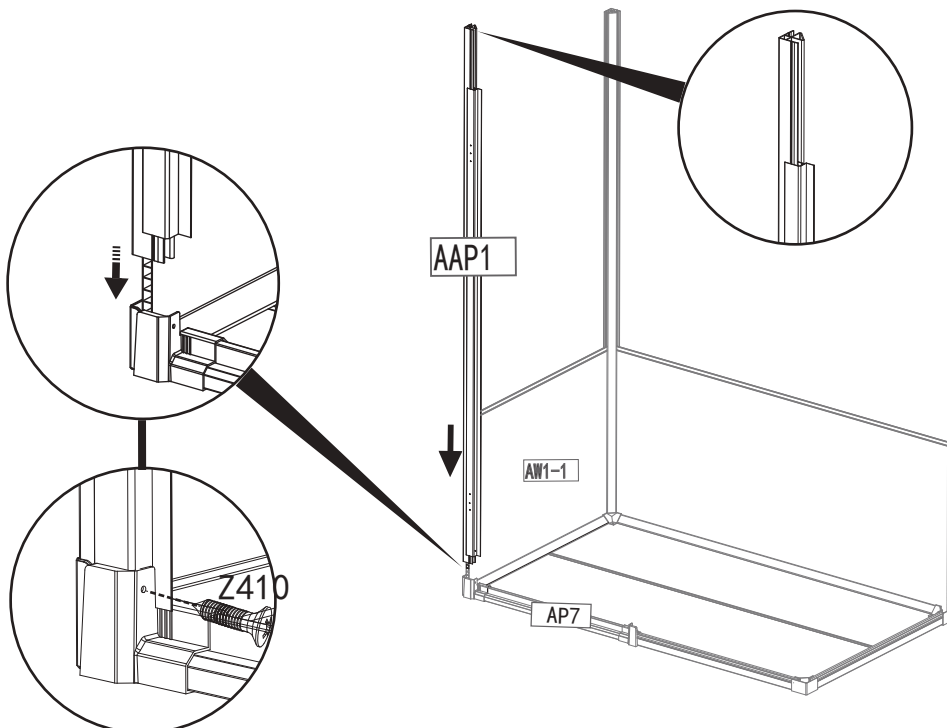

Step 14

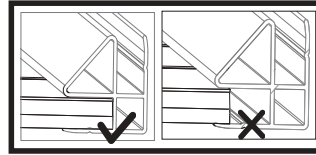

● Fully fit the panel inside the profile

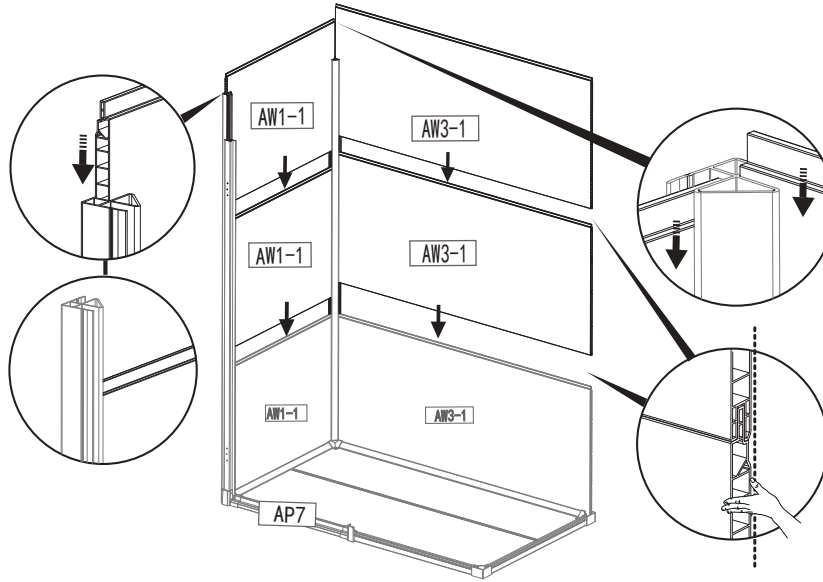
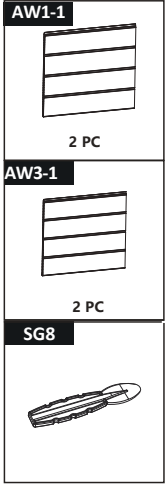

Step 15

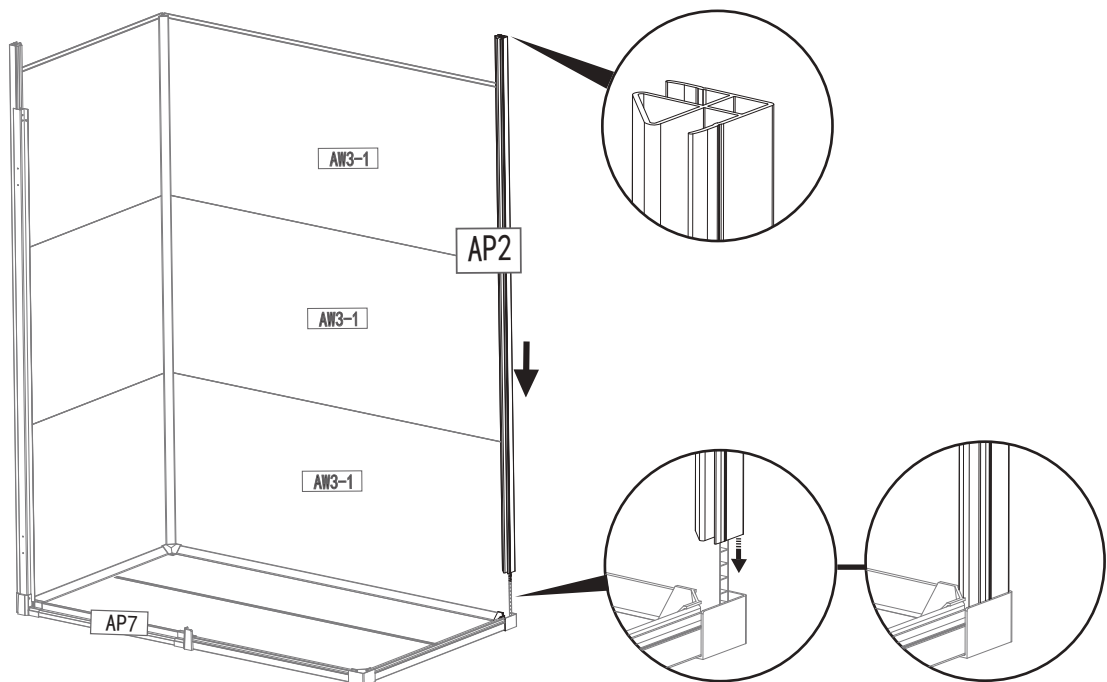
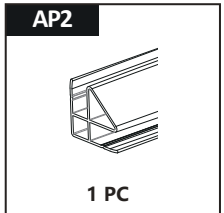

Step 16

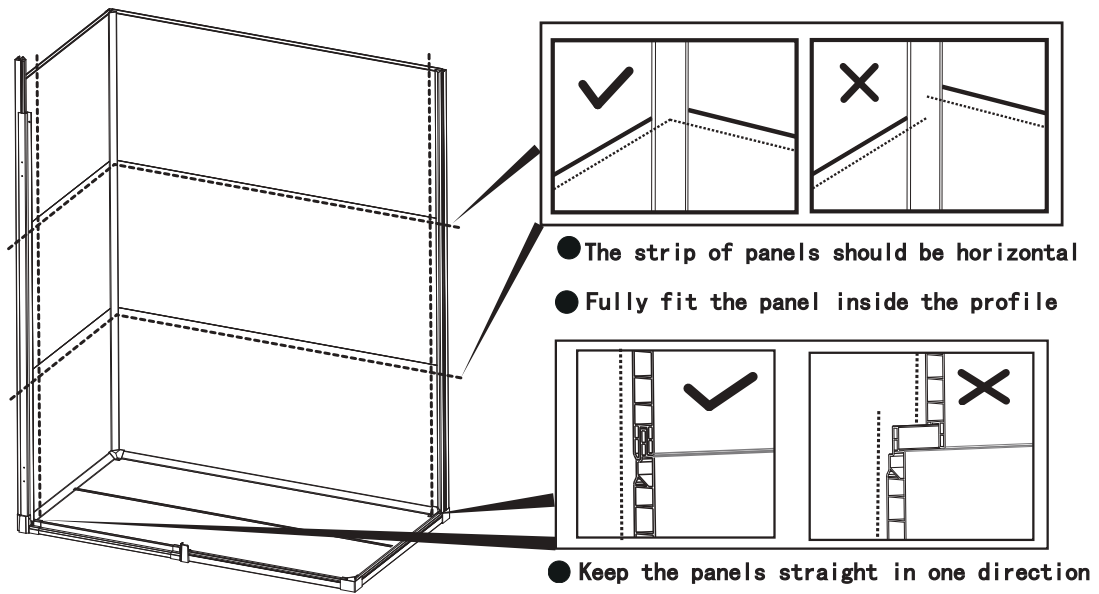

Step 17

Caution:
Please use Drill  to predrill
a hole at depth 1mm before screw.

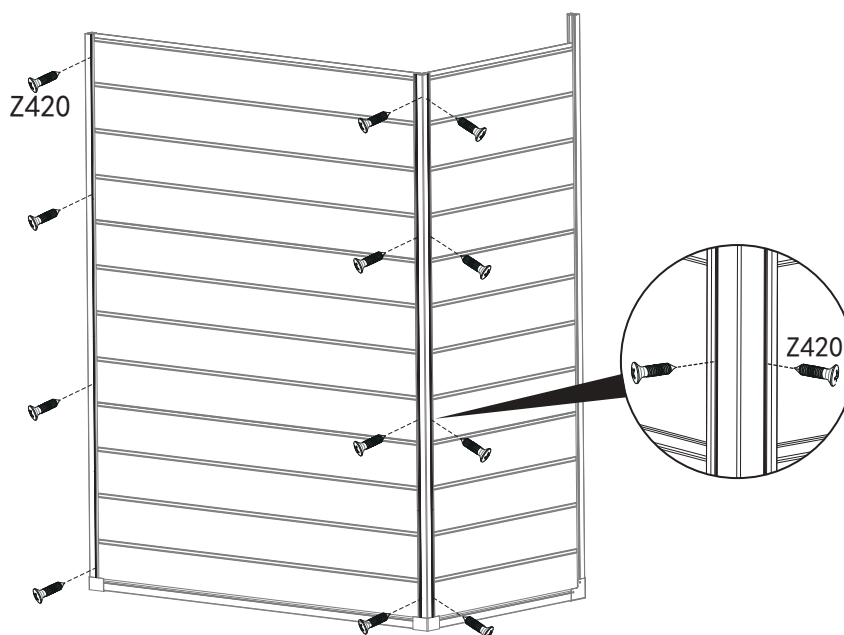
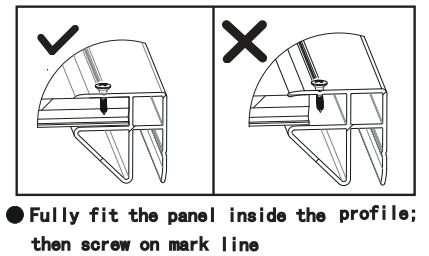
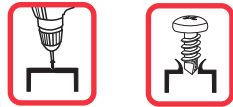

Z420



12 PC

Step 18

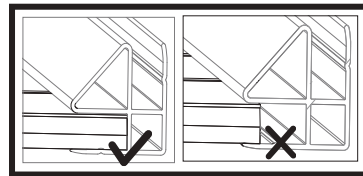

● Fully fit the panel inside the profile

AW1-1



1 PC

SG8

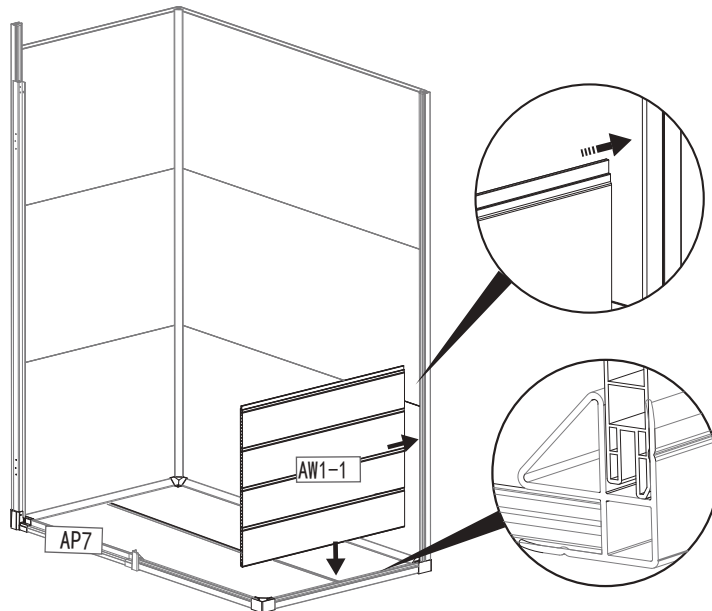

Step 19

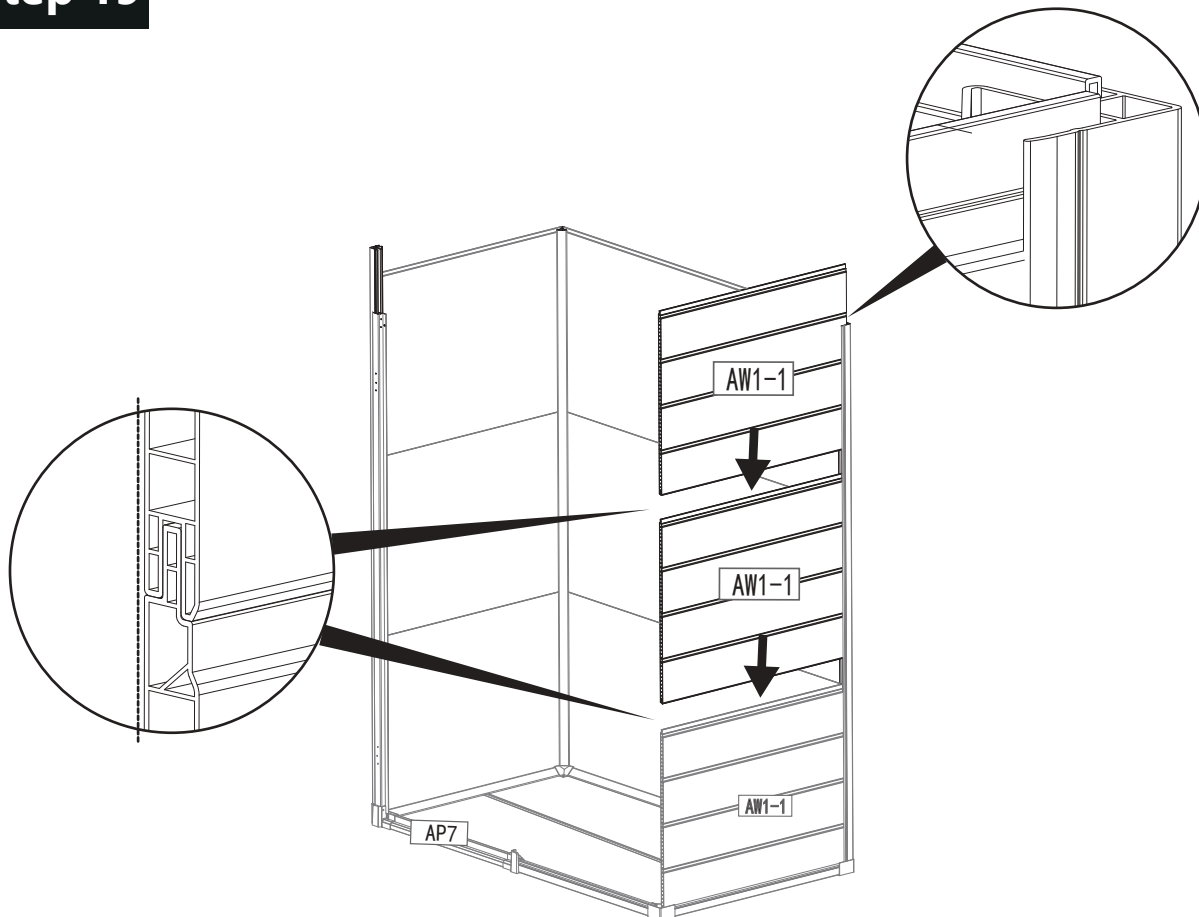

AW1-1



2 PC

SG8

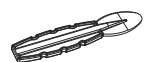

Step 20

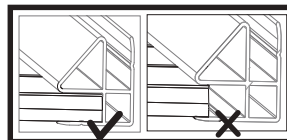
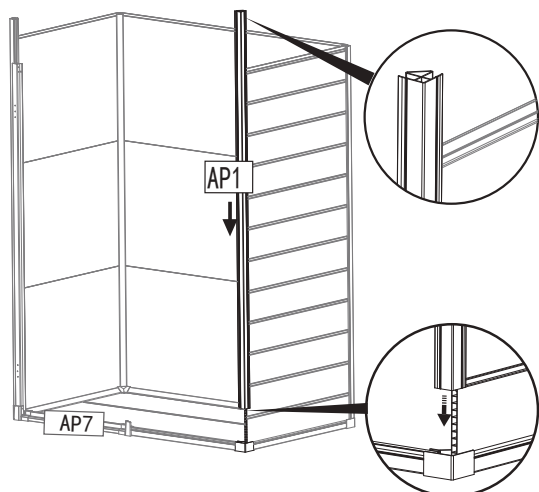

● Fully fit the panel inside the profile

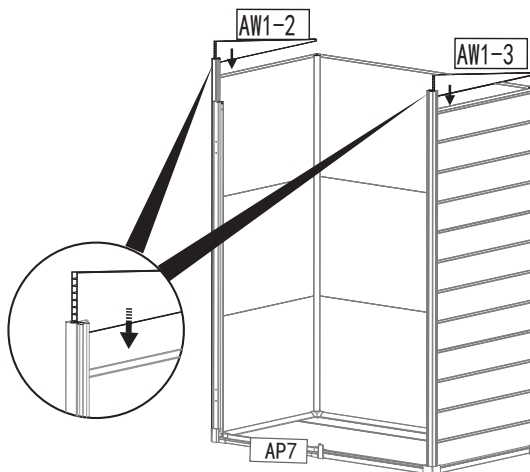
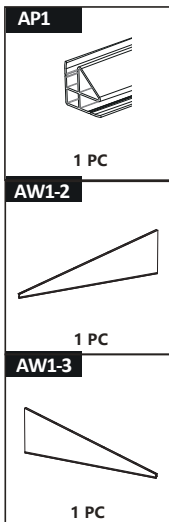

Step 21

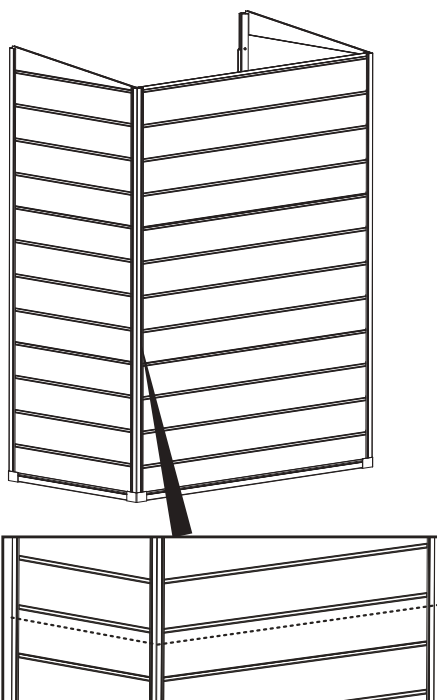

● The panels stripe should be horizontal

$$A B = C D$$

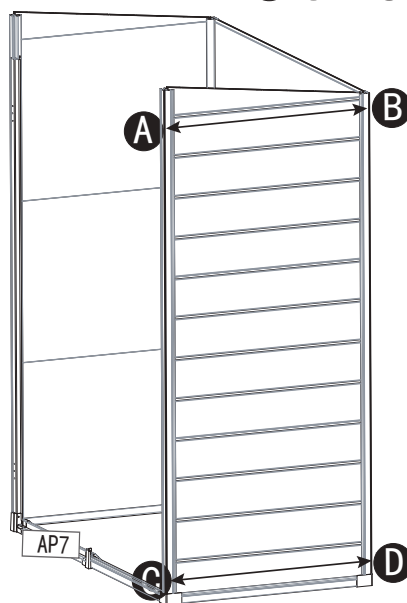

Step 22

Caution:
Please use Drill to predrill
a hole at depth 1mm before screw.

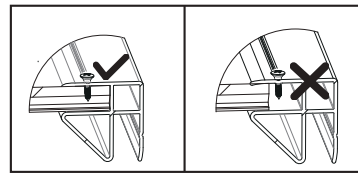
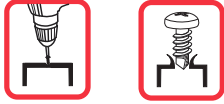

●Nail along the marked line on profile.

Z420



16 PC

●Fully fit the panel inside the profile

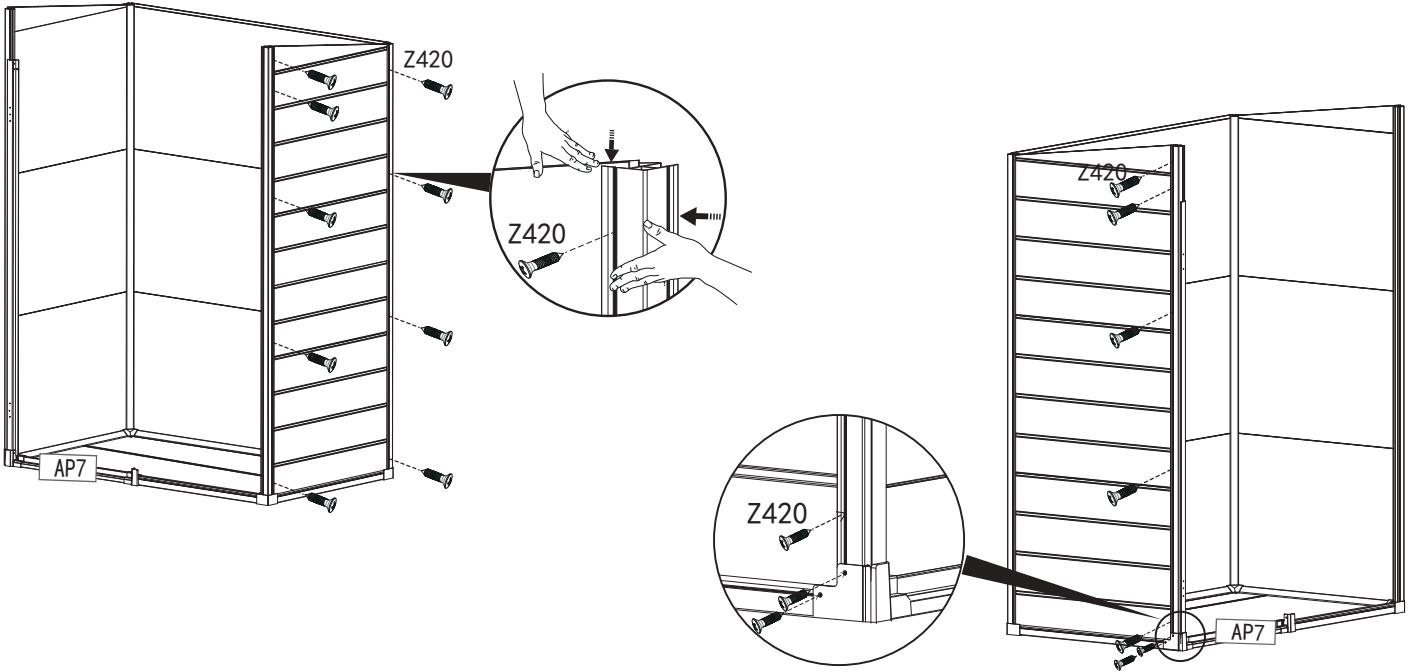

Step 23

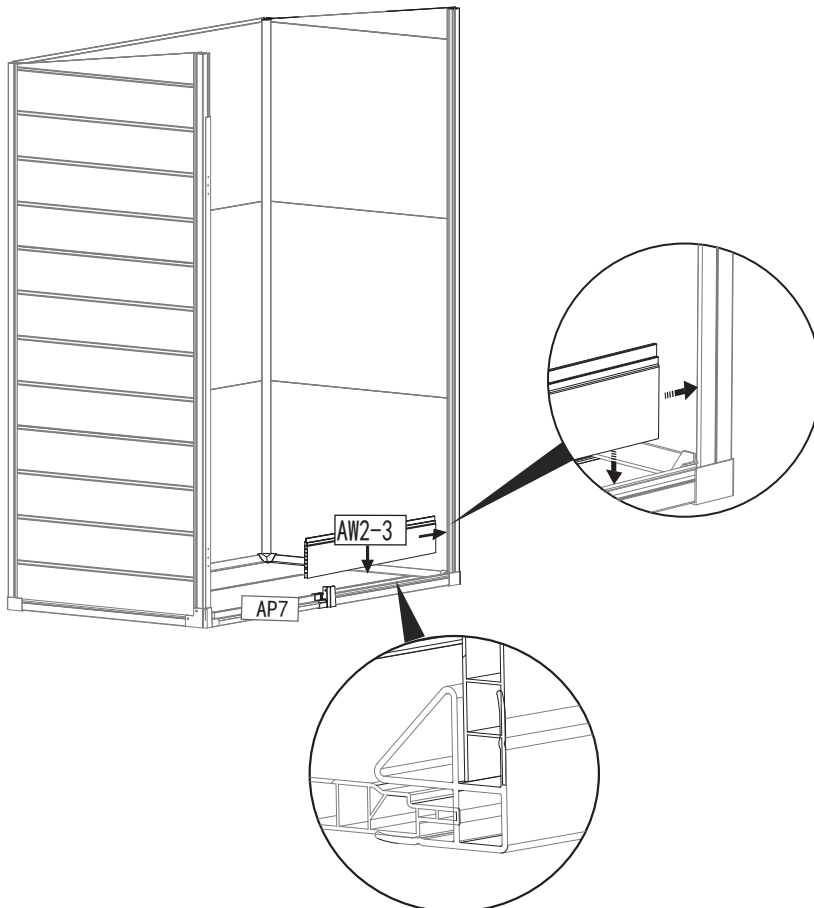

AW2-3

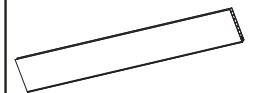

1 PC

SG8

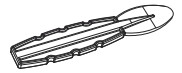

Step 24

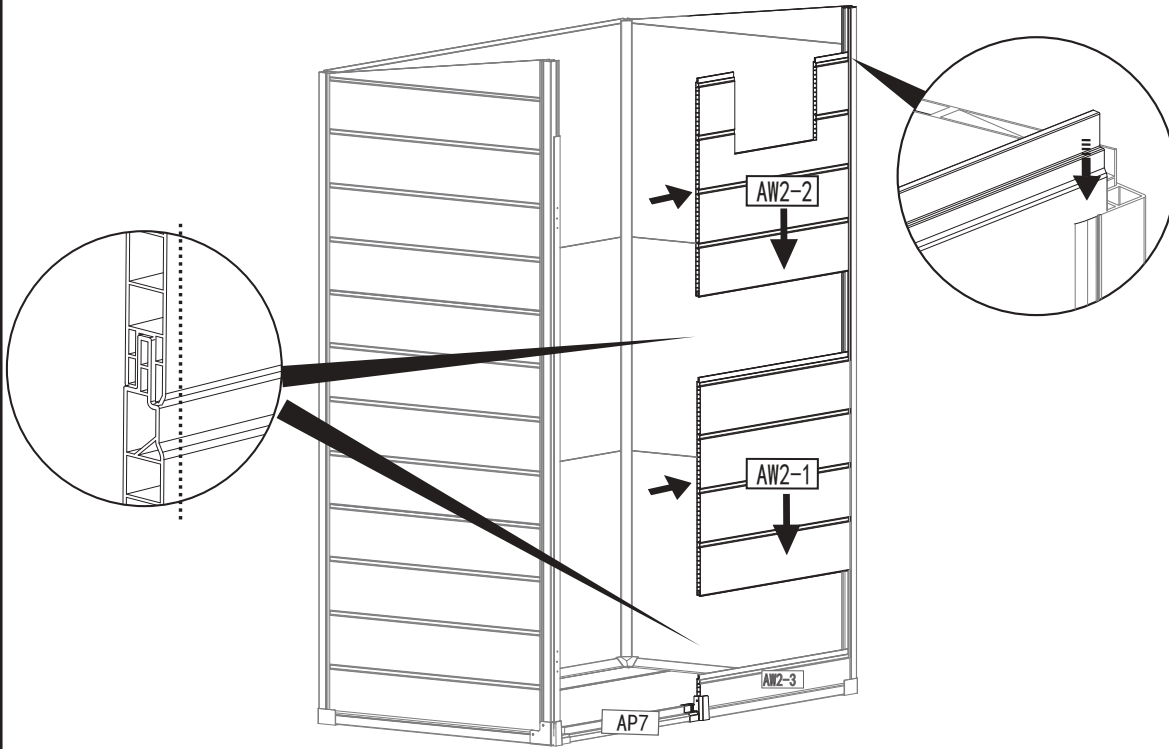

AW2-1



1 PC

AW2-2

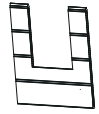

1 PC

SG8



Step 25

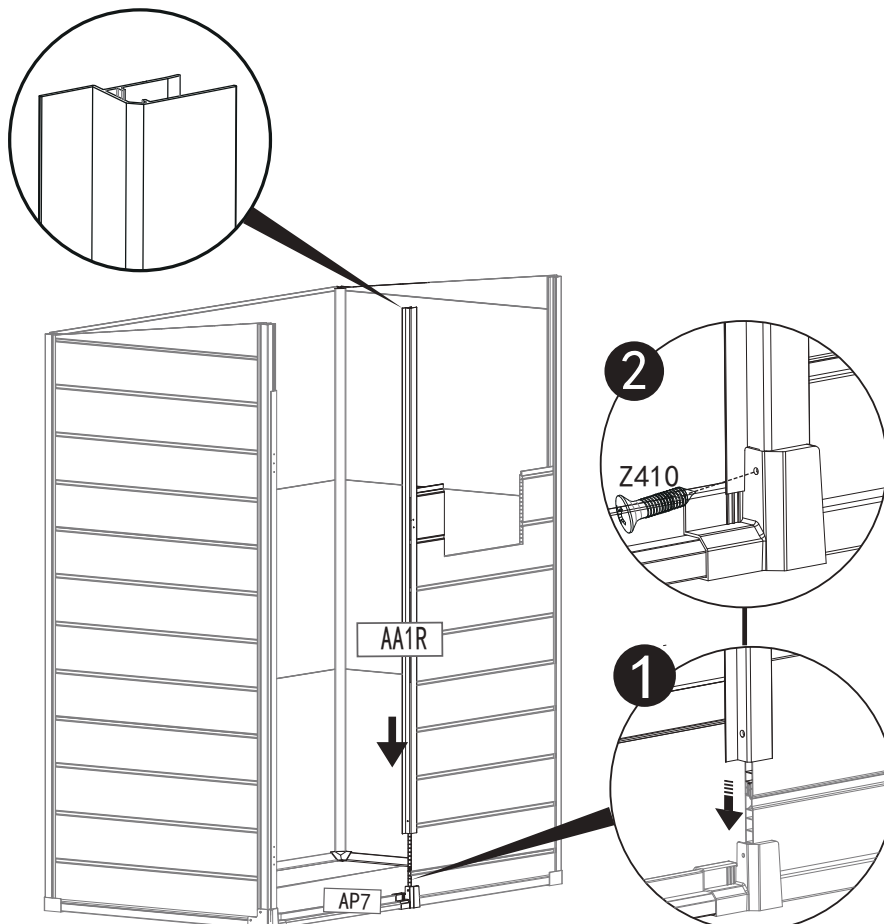

AA1R

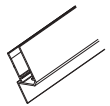

1 PC

Z410



1 PC

Step 26

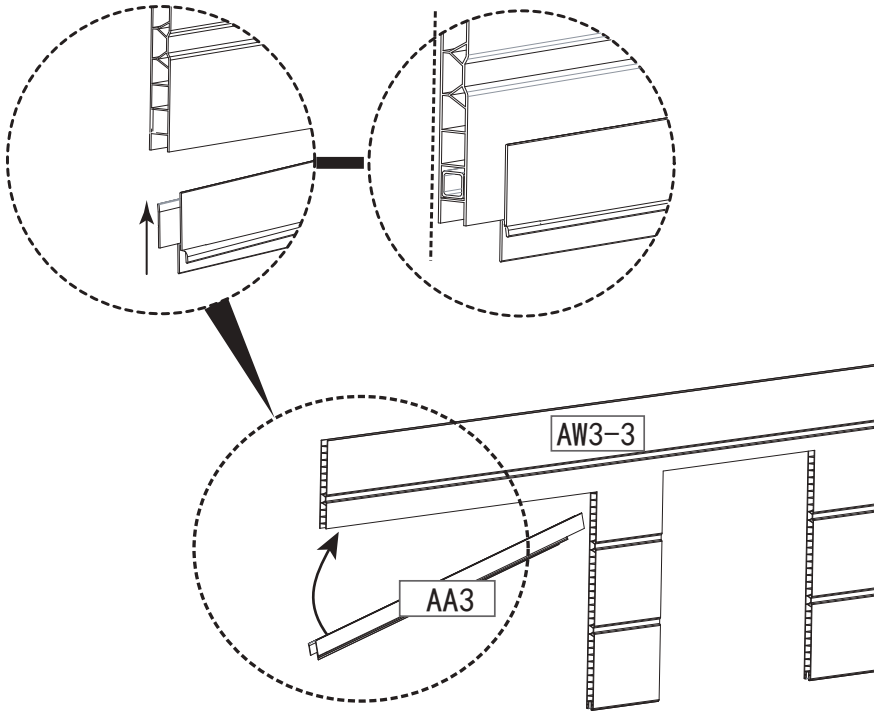

AW3-3

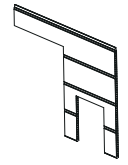

1 PC

AA3

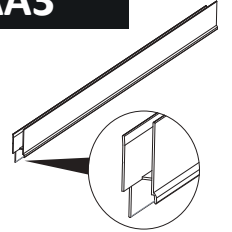

1 PC

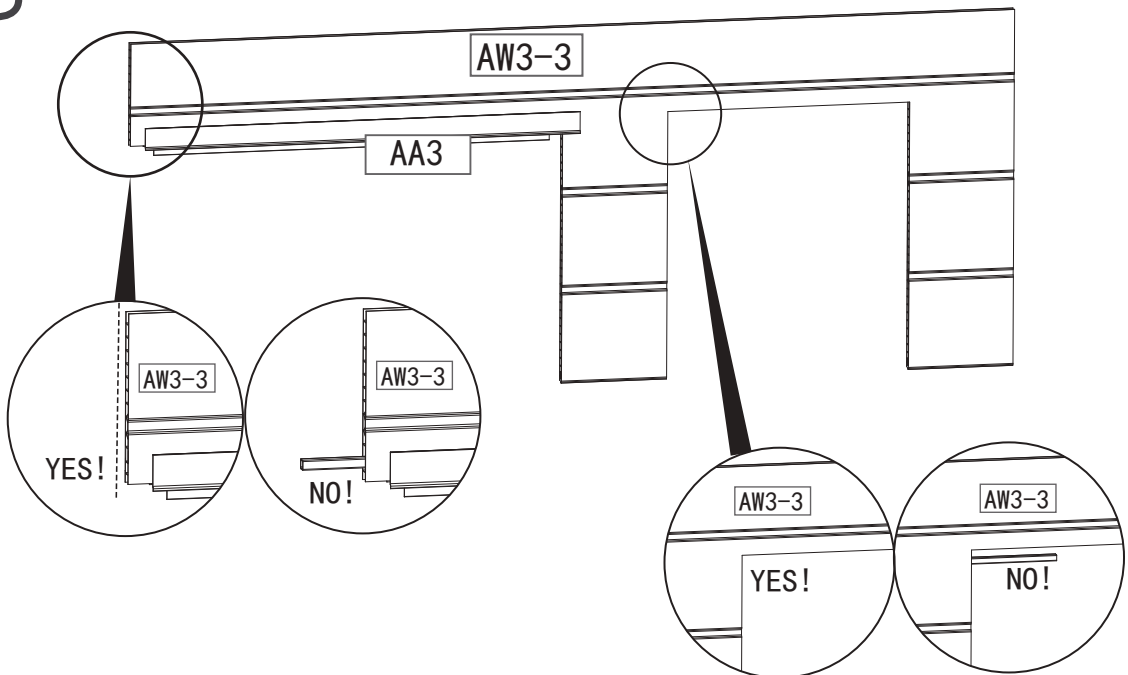

Step 27

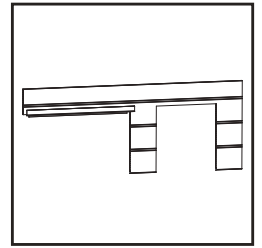
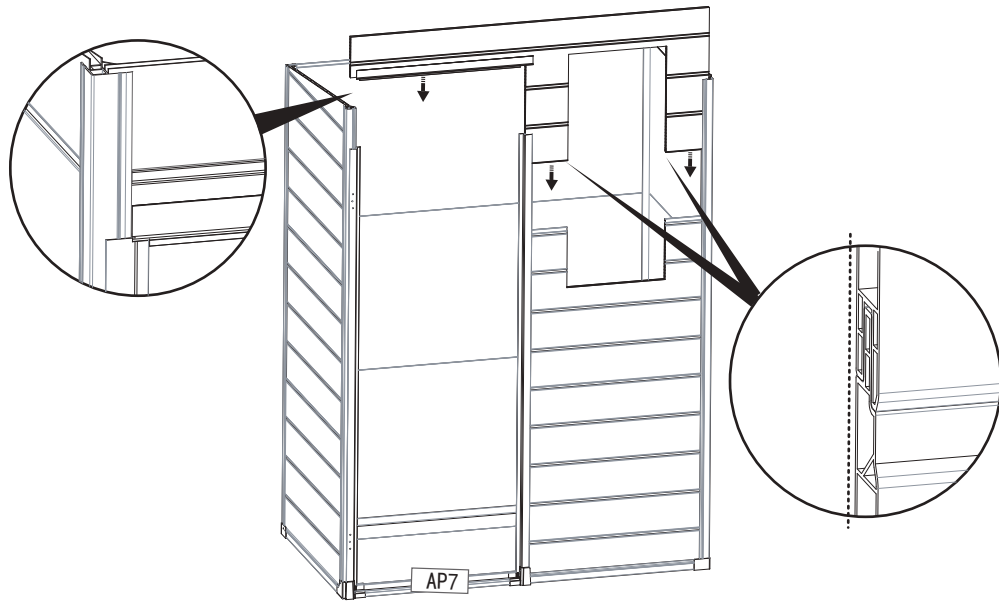

Step 28

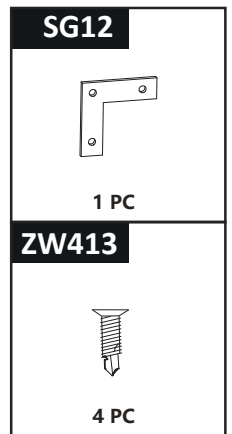
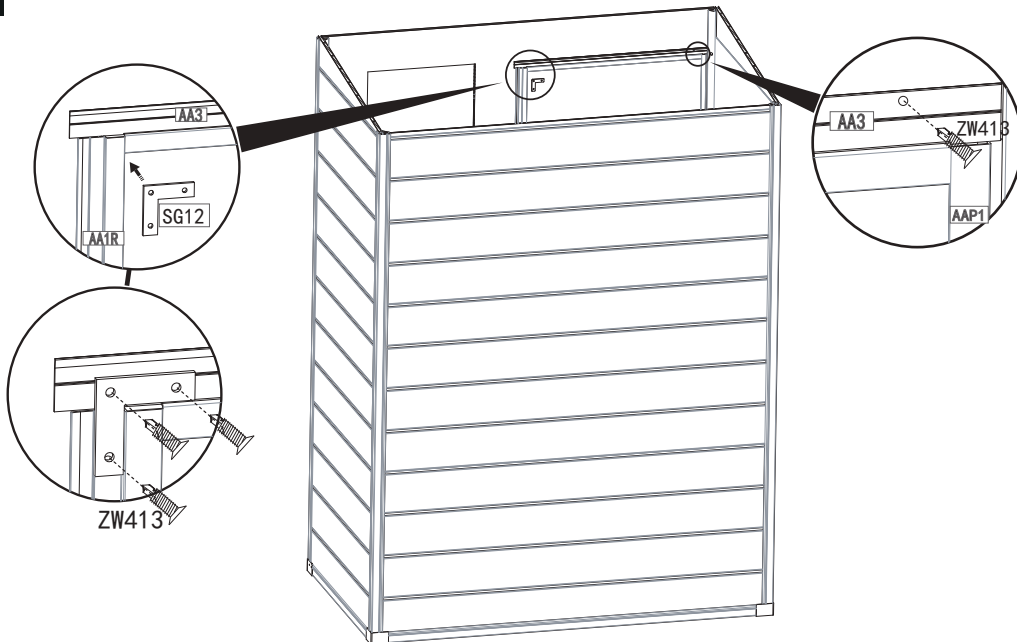

• fixation after aligning!

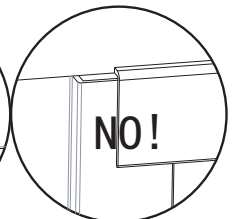
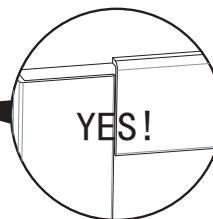
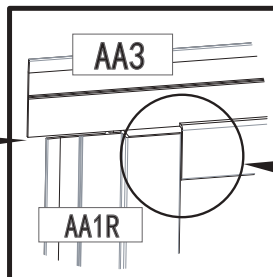
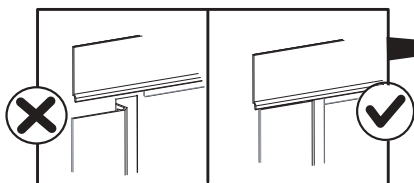

Step 29

Caution:
Please use Drill  to predrill
a hole at depth 1mm before screw.



A B = C D

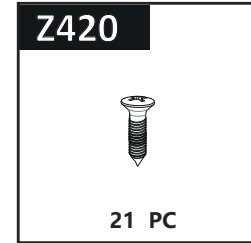
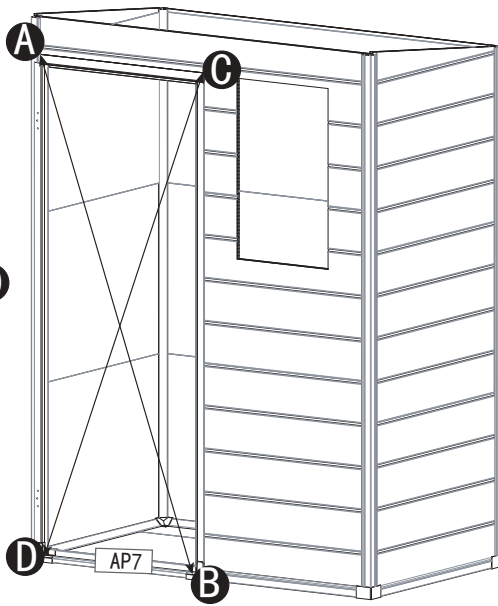

● Fully fit the panel inside the profile

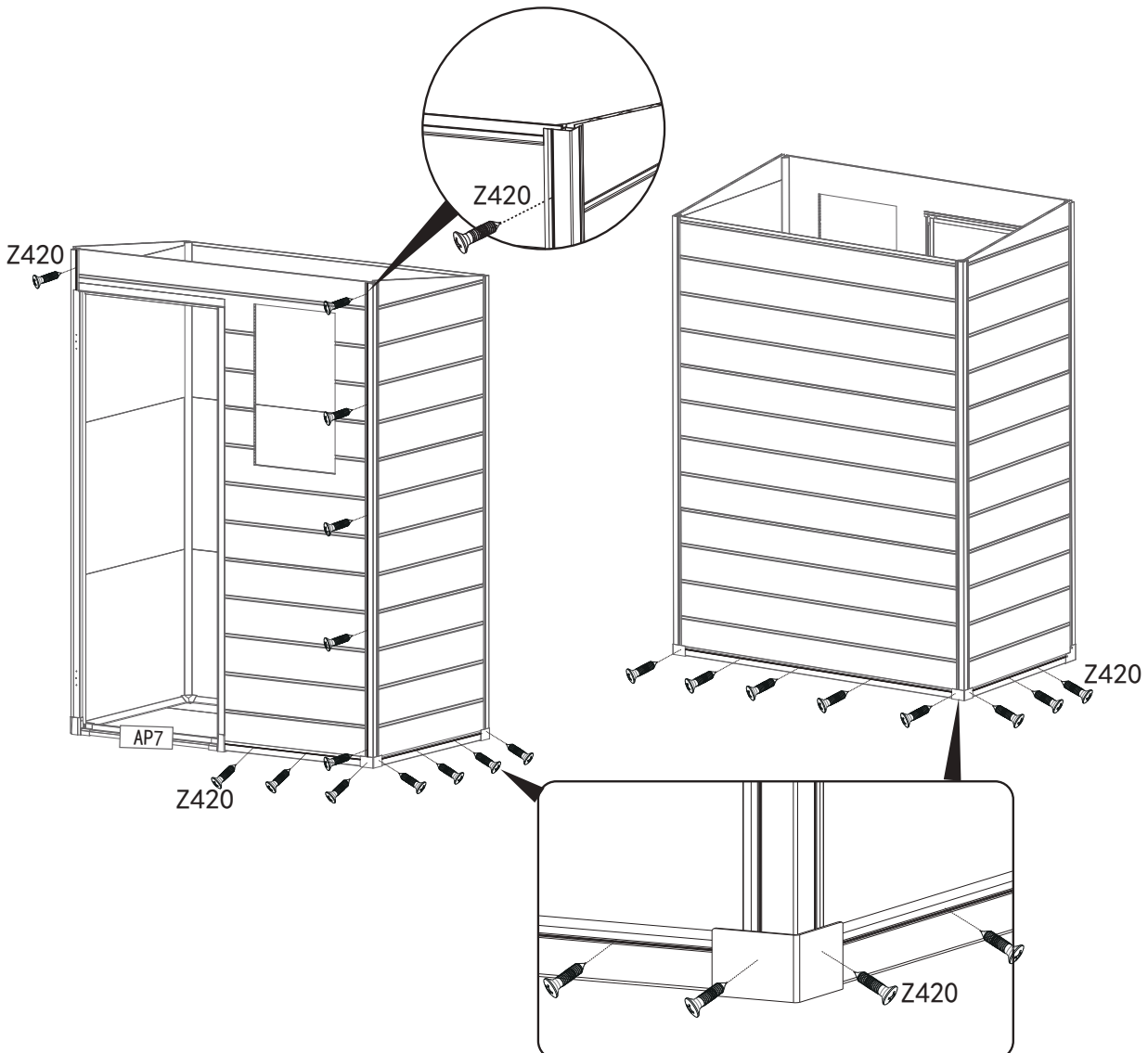

Roof Assembly

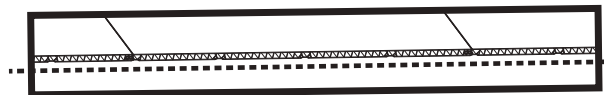

● The panels must be straight

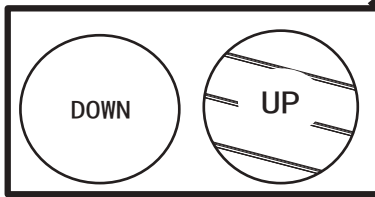
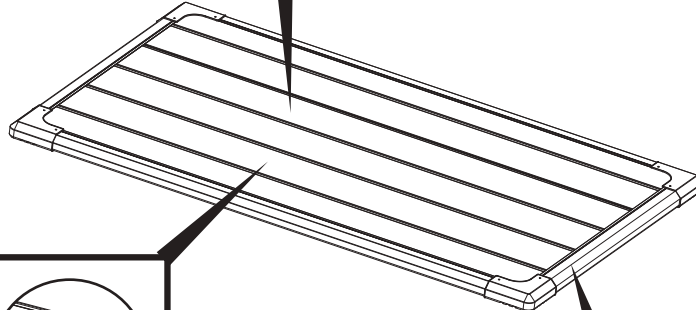

● The stripes should be upwards

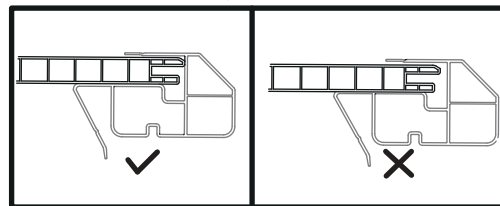

● Fully fit the panel inside the profile

Step 30

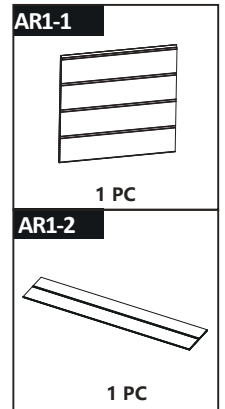
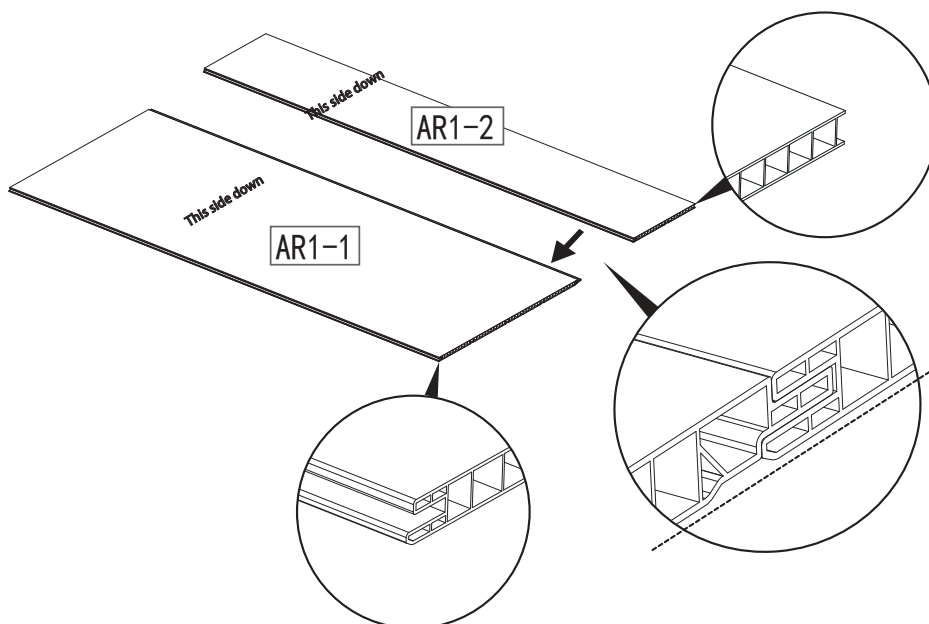

Step 31

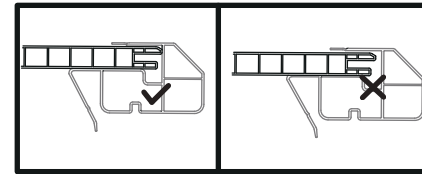
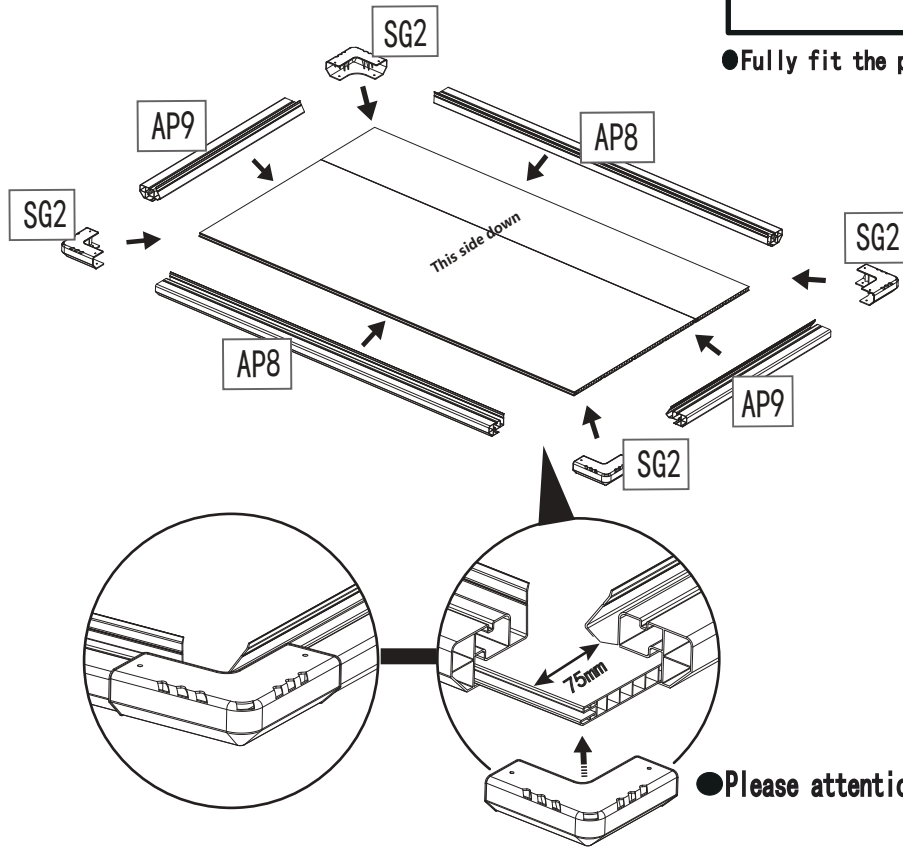

● Fully fit the panel inside the profile

AP8



2 PC

AP9



2 PC

SG2

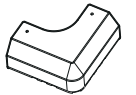

4 PC



SG8



● Please attention to the size before install

Step 32

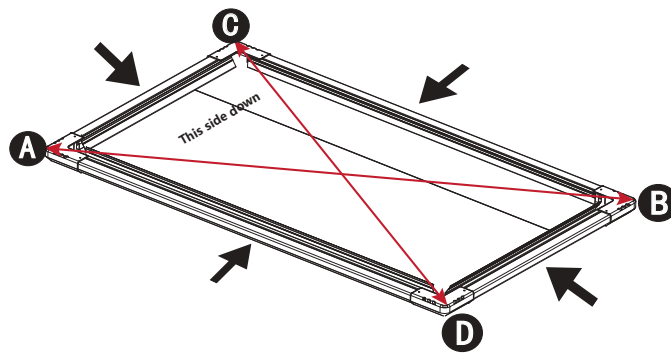

● Make sure $AB=CD$

Z410



8 PC

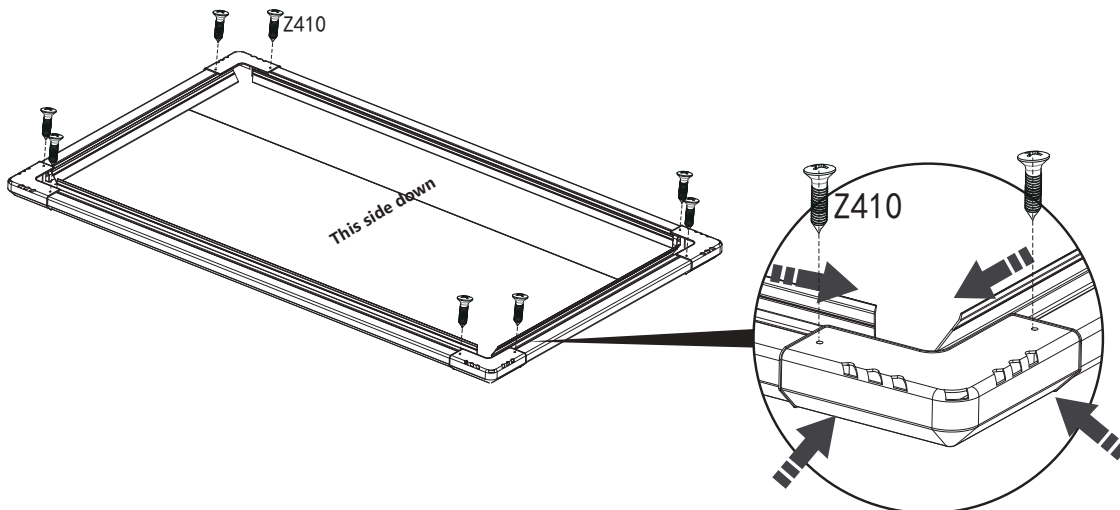

Step 33

● Turn over the roof panel

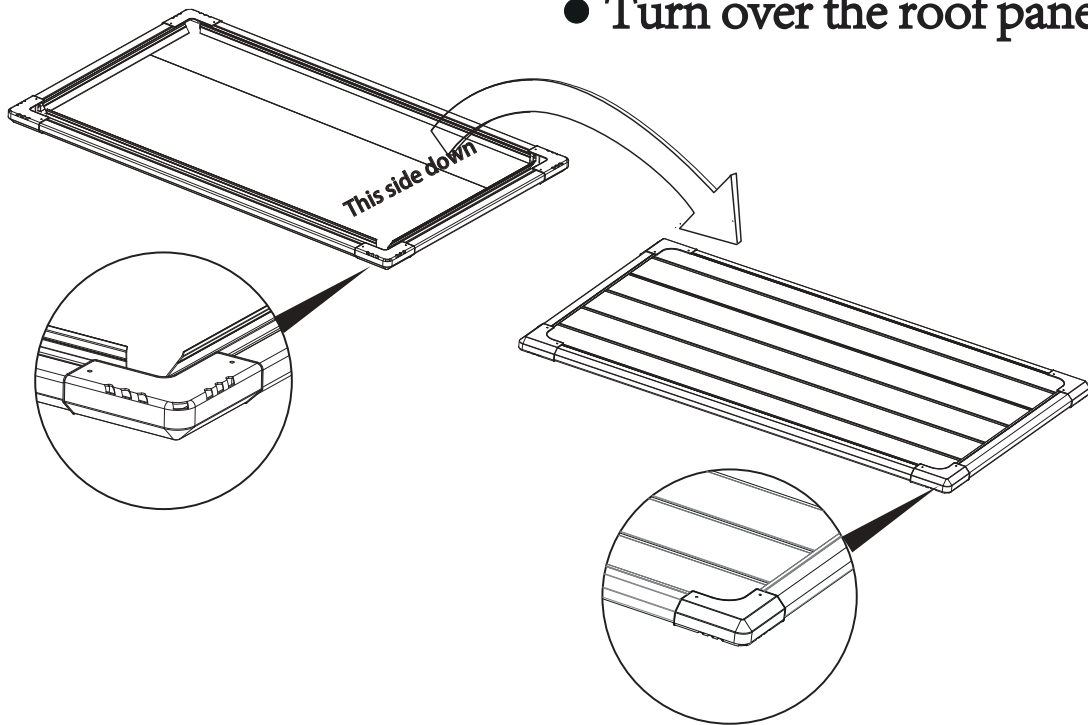

Step 34

Caution:
Please use Drill  to predrill
a hole at depth 1mm before screw.

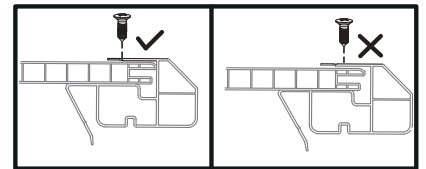
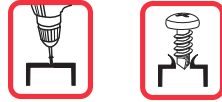

● Nail along the marked line on profile.

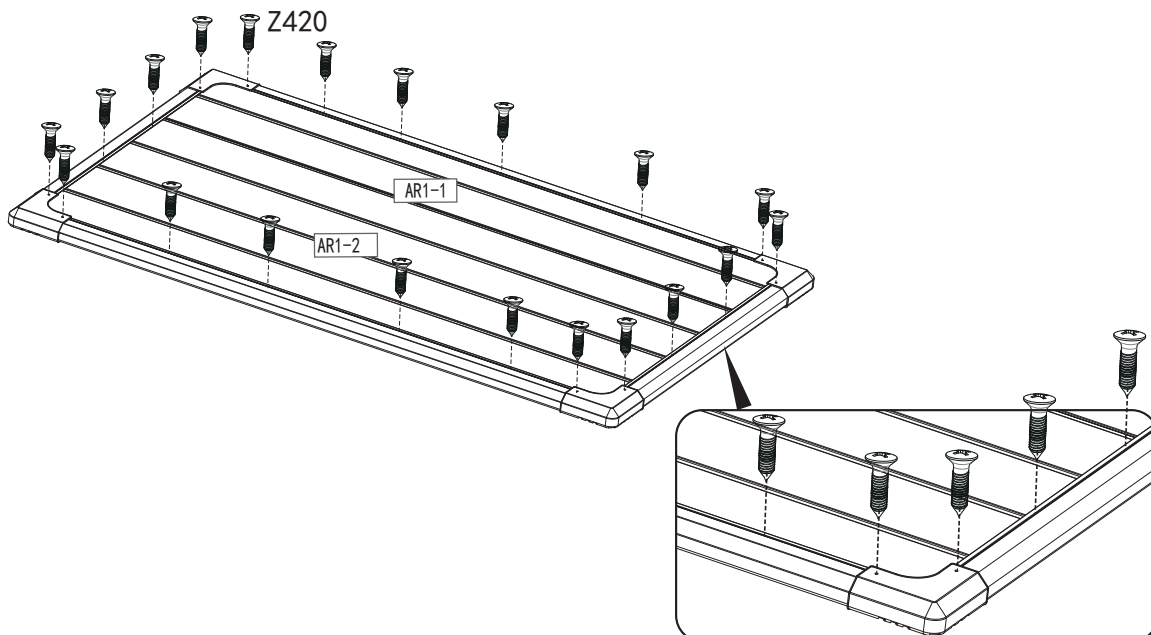

Z420



20 PC

Step 35

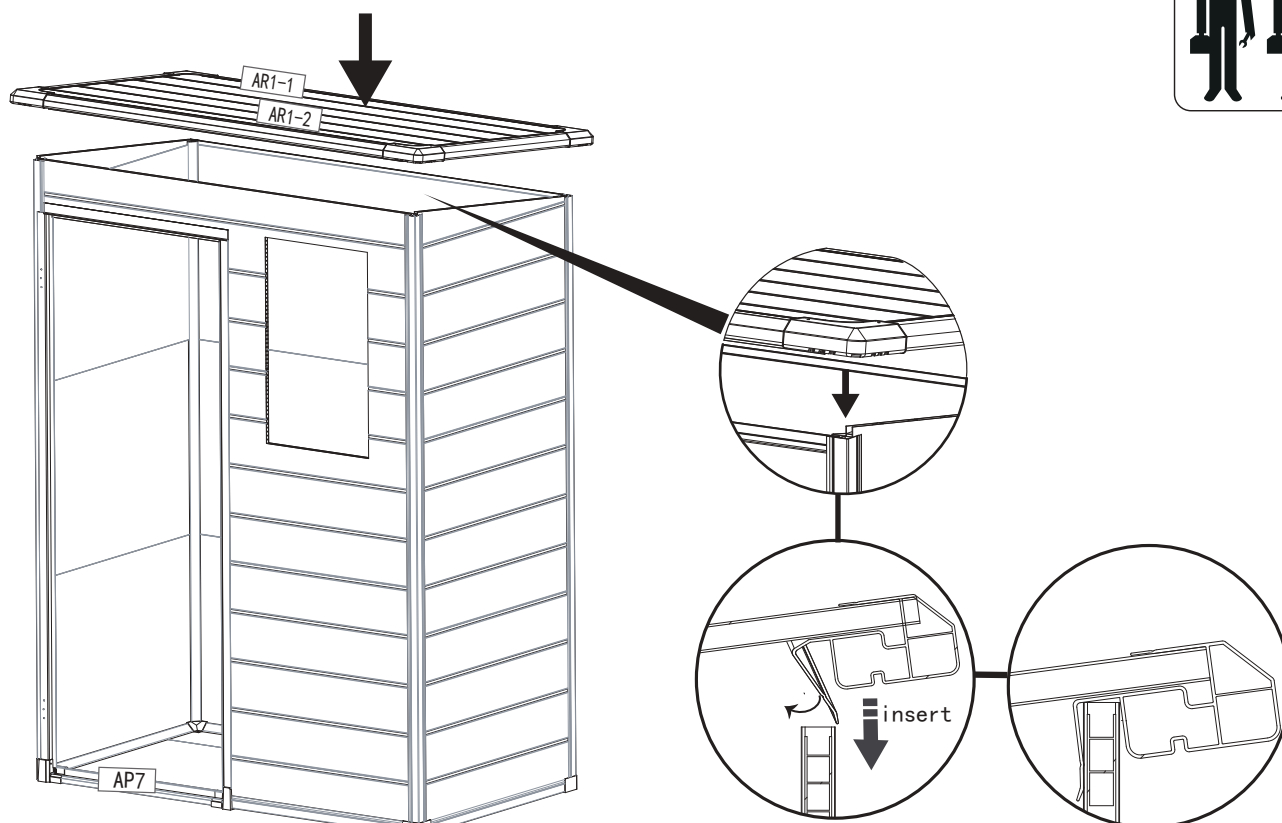
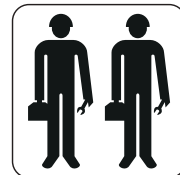

- Fully fit the panel inside the profile

Step 36



- Ensure fully fit the panels inside the profiles of the roof, using the spatula according to the following picture.

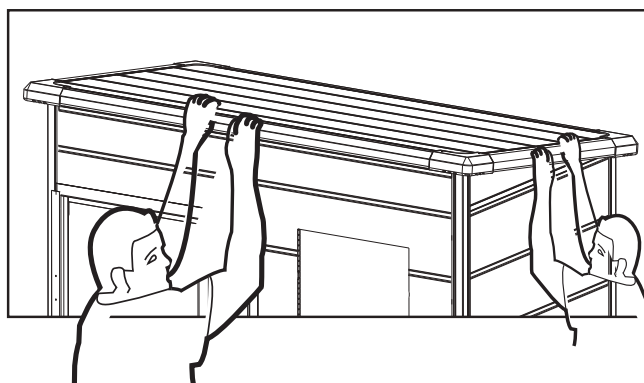
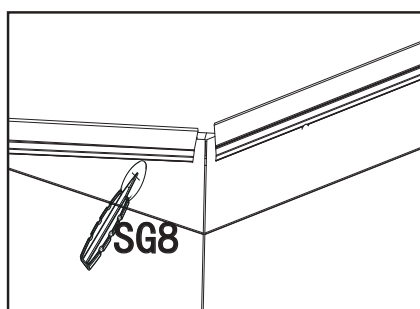

Step 37

• Please note the nailing direction.

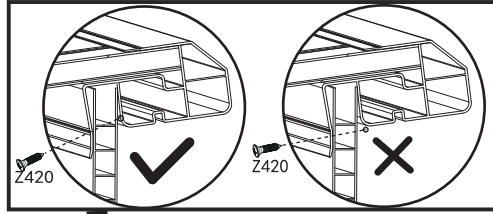

Z420



12 PC

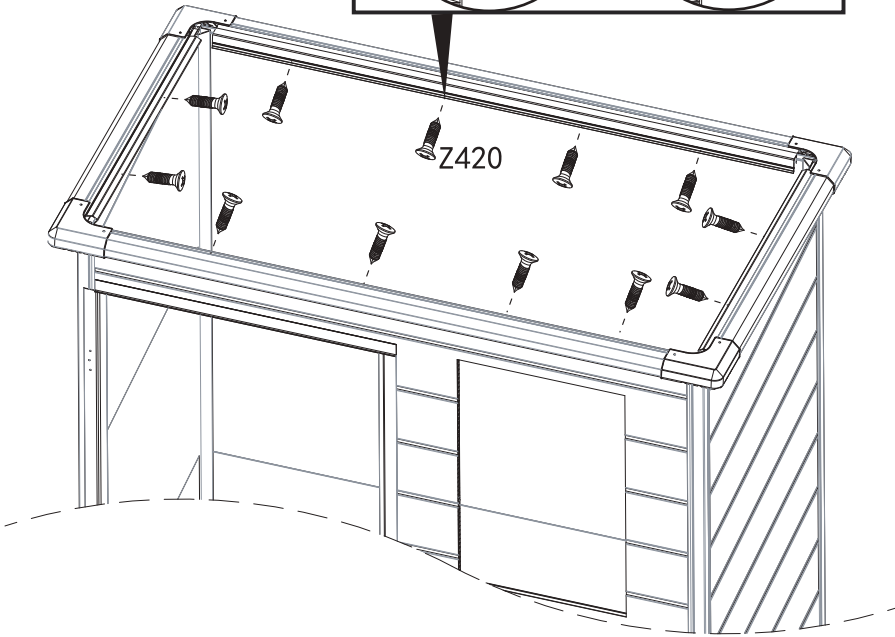
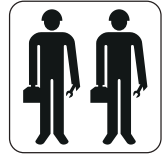

Caution:

Please use Drill  to predrill a hole at depth 1mm before screw.



Step 38

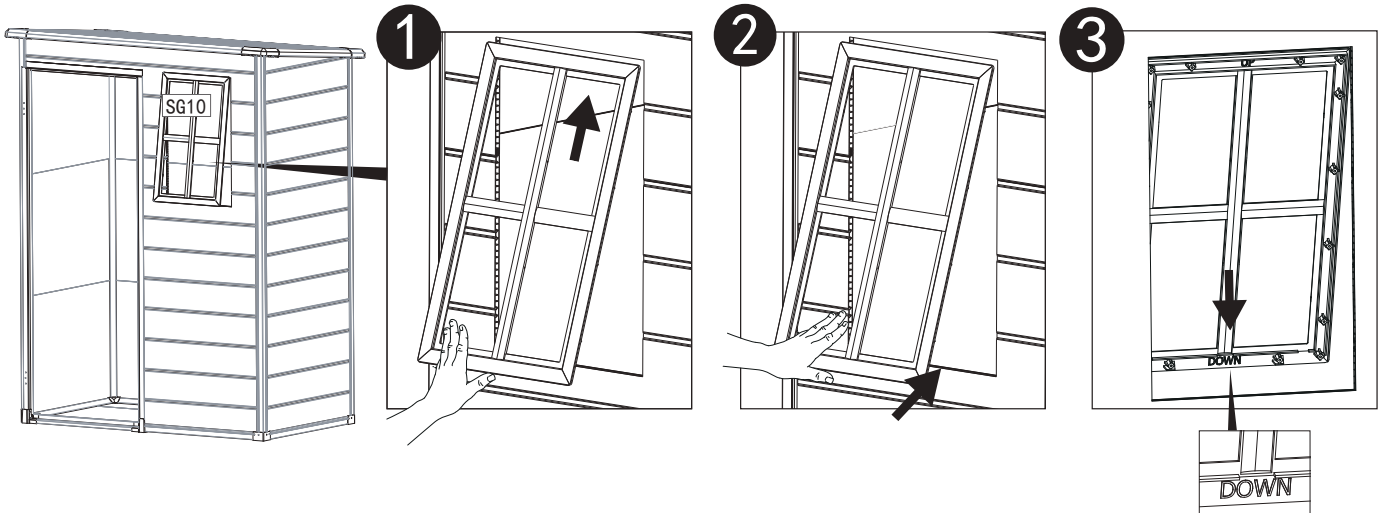
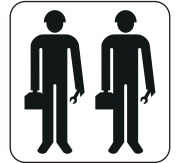

Step 39

- Remove the film before fixing SG101

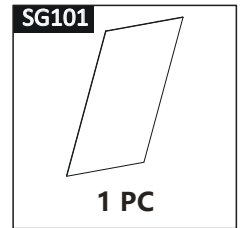
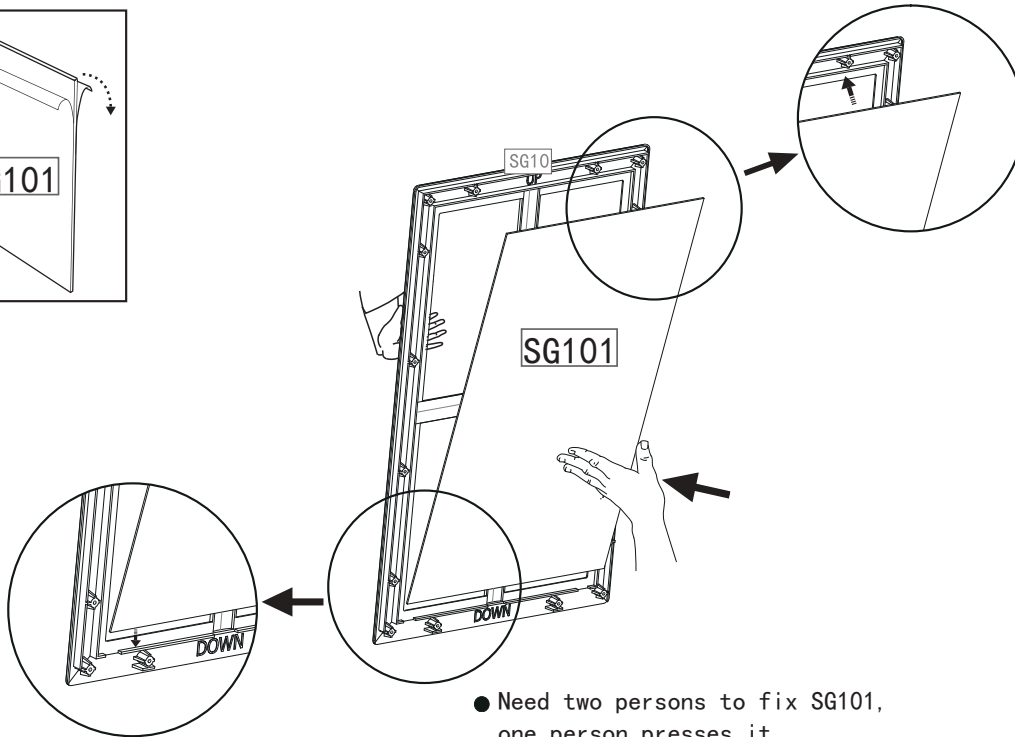
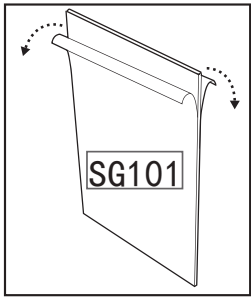

- Need two persons to fix SG101, one person presses it, and the other person assembles it.

Step 40

The press plate boss section shall be pressed against SG101

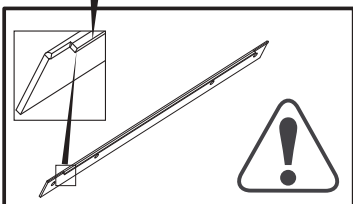

- Press tightly to avoid falling down
- Please note the side with bending edge be pressed to SG101
- It's better to fix just one screw on each SG102&SG103 before each one adjust into right location.

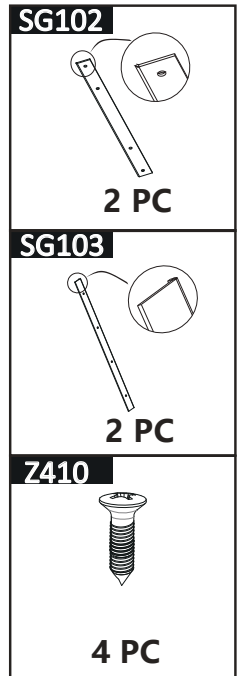
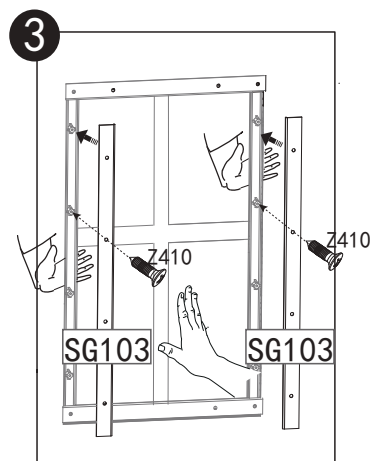
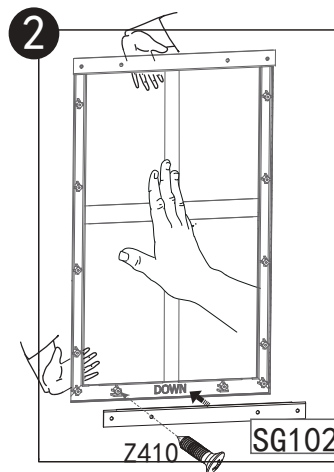
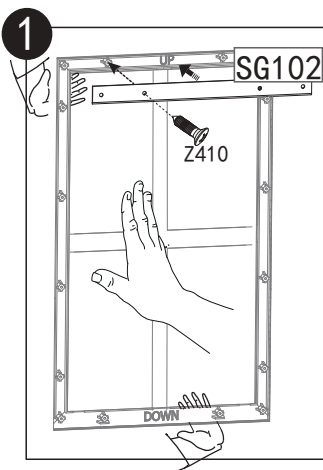

Step 41

Z410

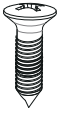

12PC

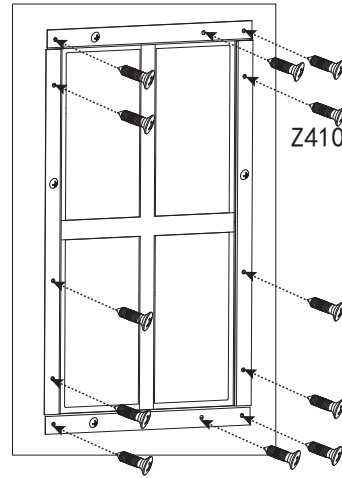
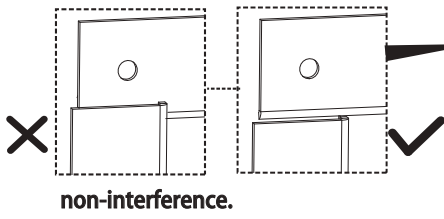

- Adjust SG102&SG103 in right location, then fix all screws



- How the Windows look when they are installed

DOOR SECTION

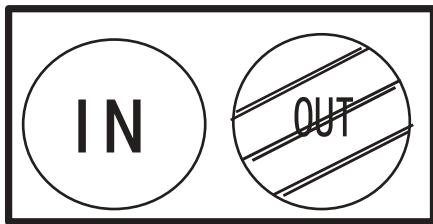

The stripes should be outside

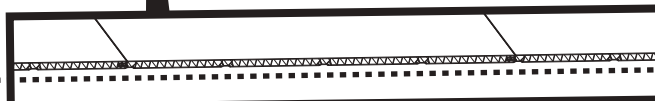
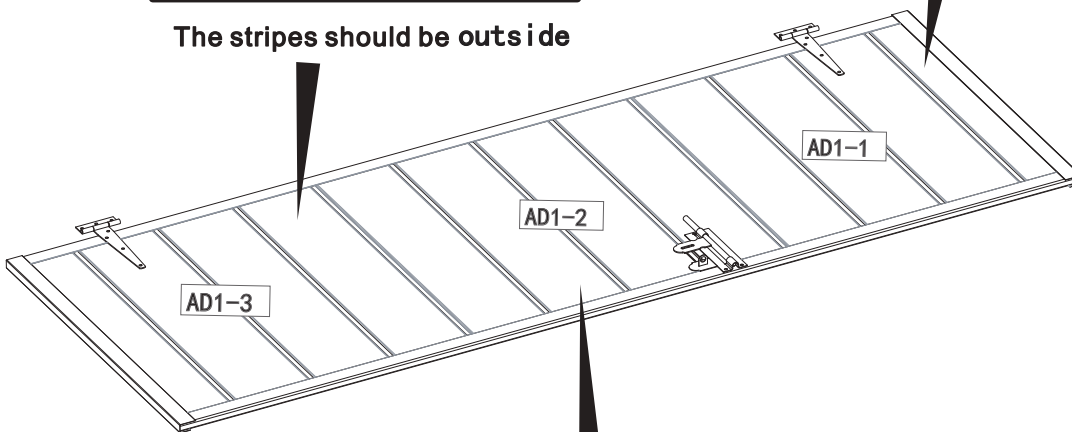

Door mount this is above

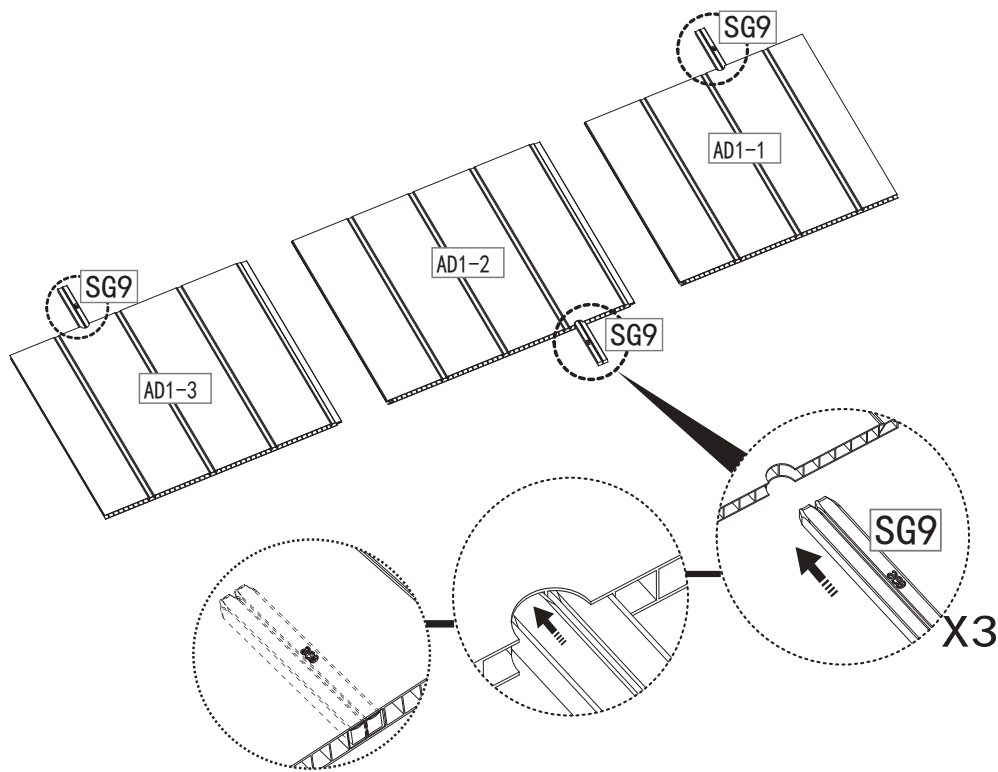

The boards must be straight

Step 42

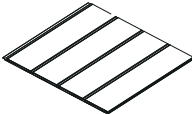
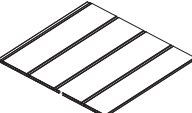
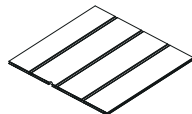

AD1-2		1 PC
AD1-3		1 PC
AD1-1		1 PC
SG9		3 PC

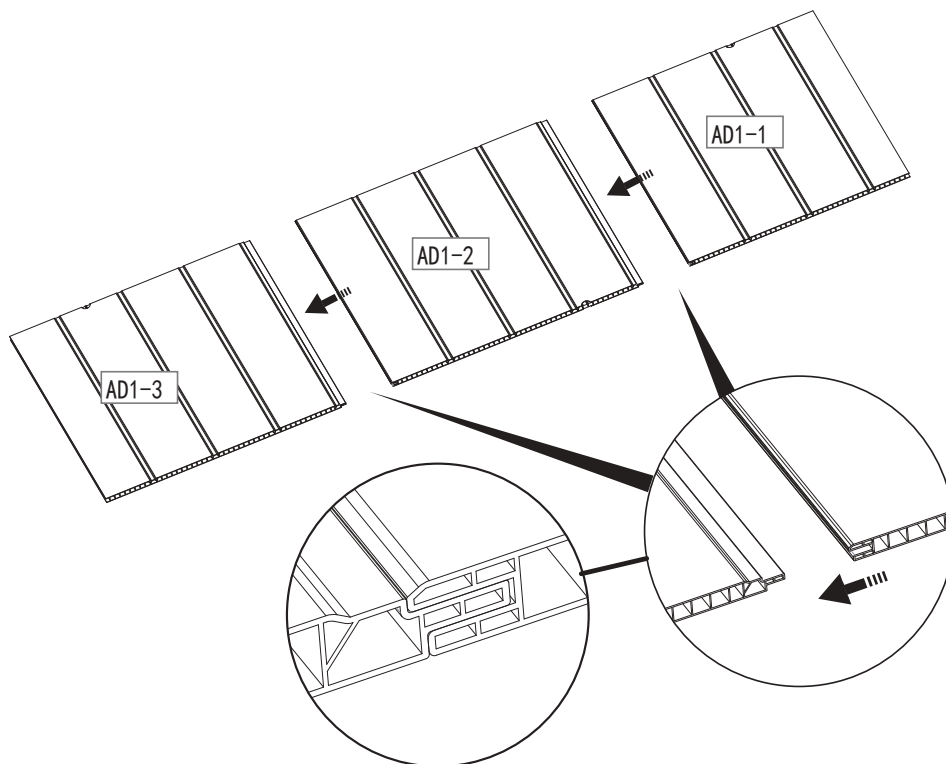

Step 43

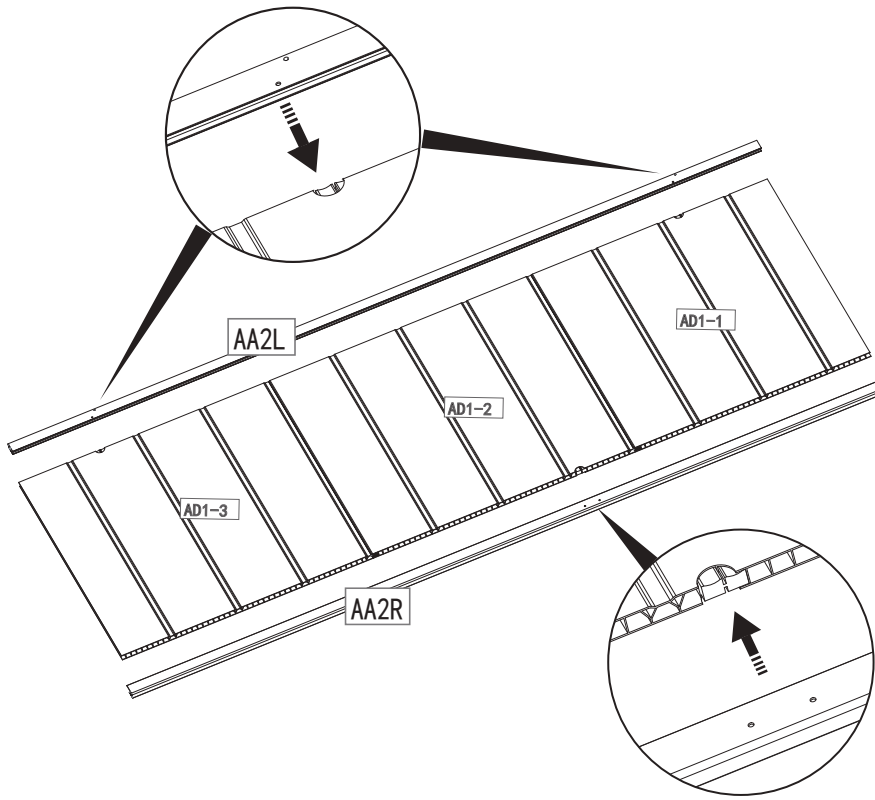

AA2R

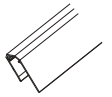

1 PC

AA2L



1 PC

Step 44

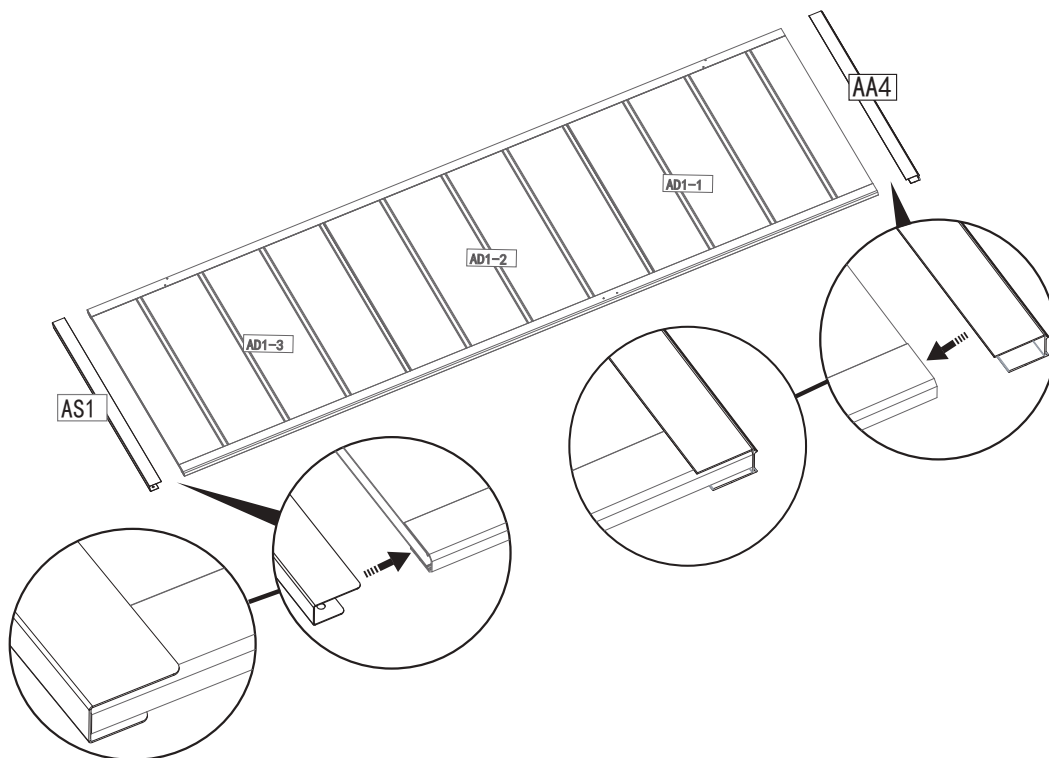

AA4

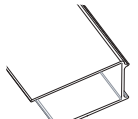

1 PC

AS1

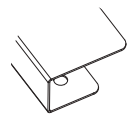

1 PC

Step 45

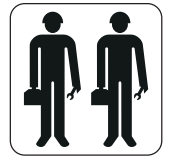

Turn the doors over

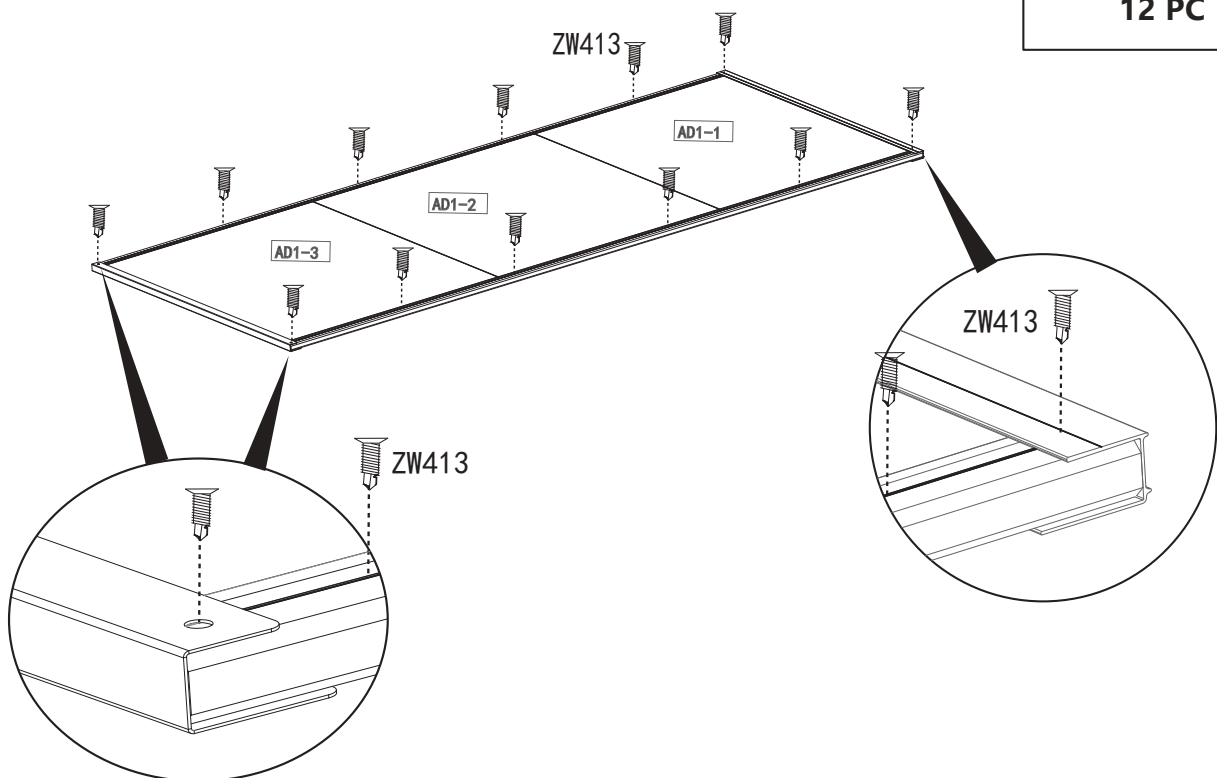
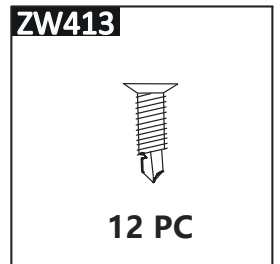
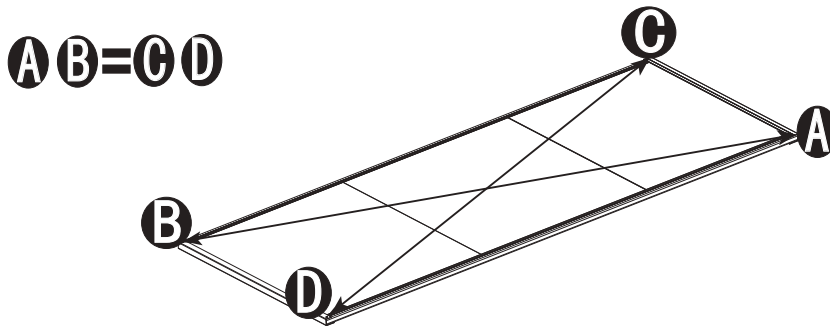
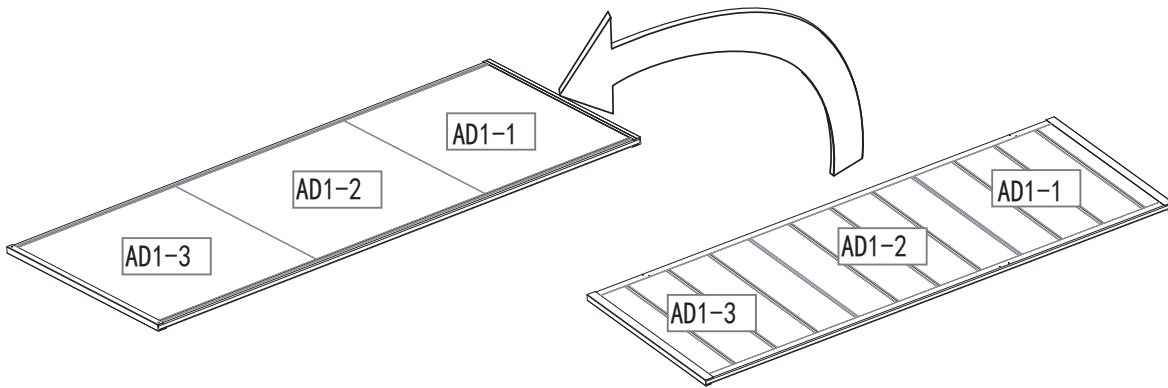

Step 46

Turn the doors over

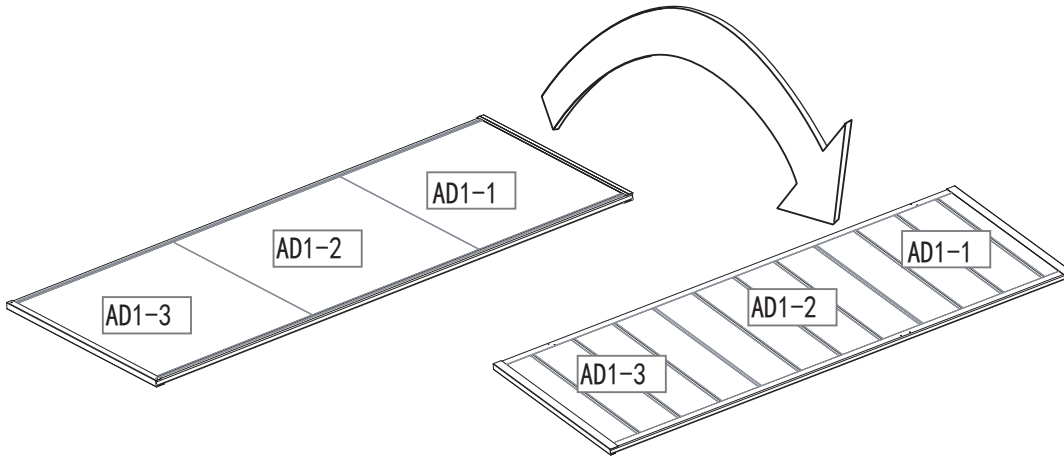

Step 47

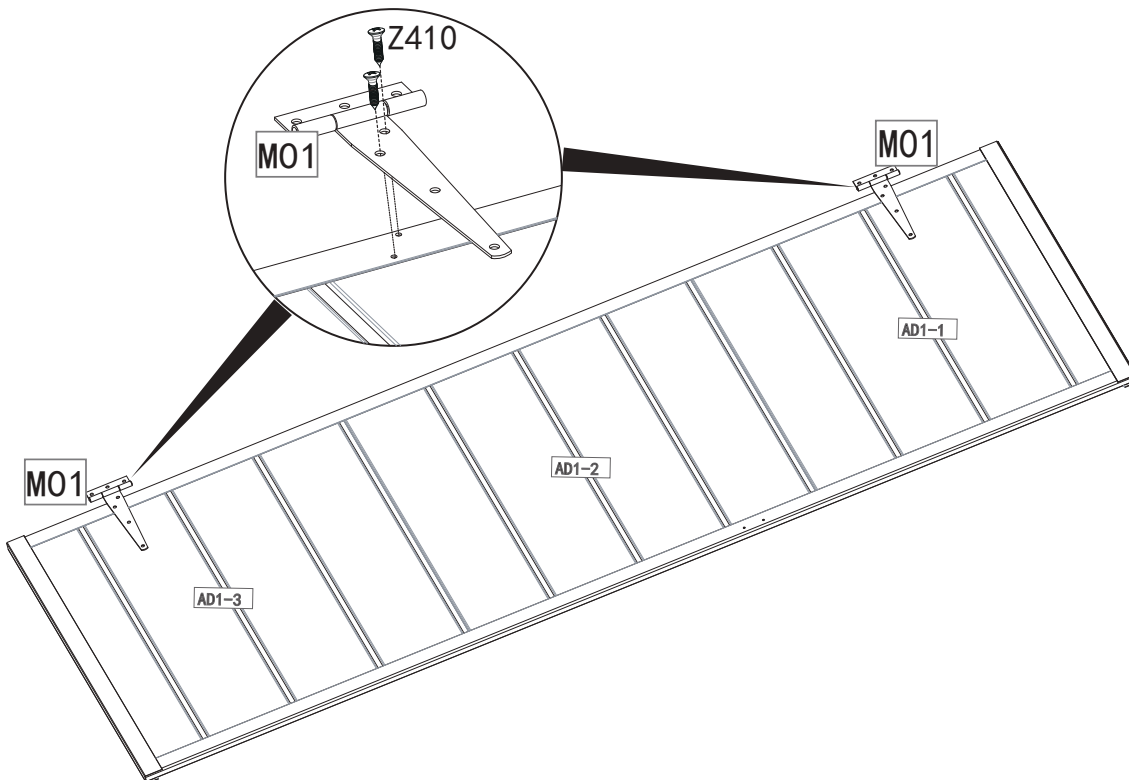

Z410



4 PC

MO1

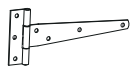

2 PC

Step 48

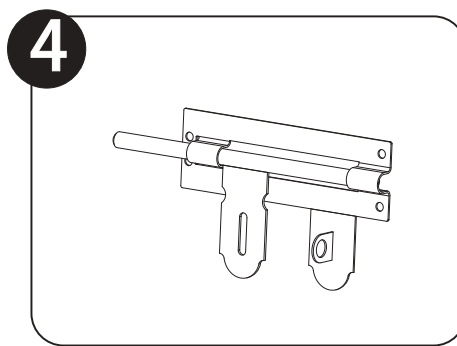
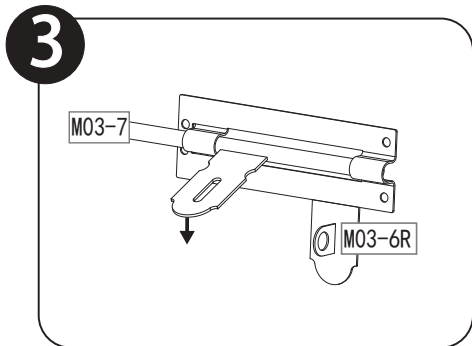
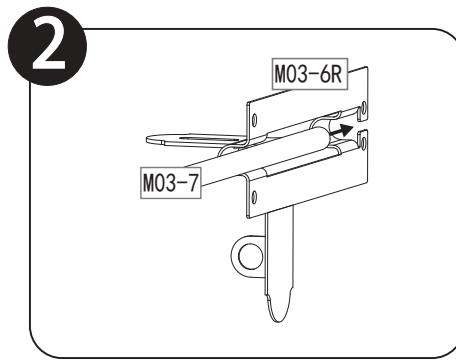
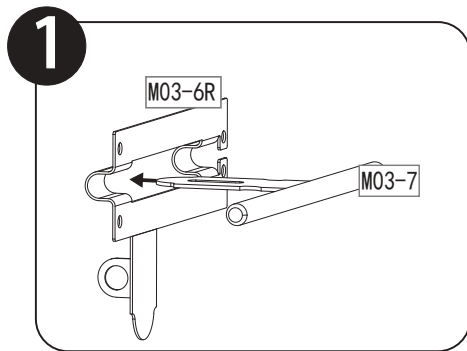

M03-6R

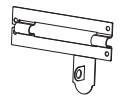

1 PC

M03-7

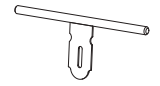

1 PC

Step 49

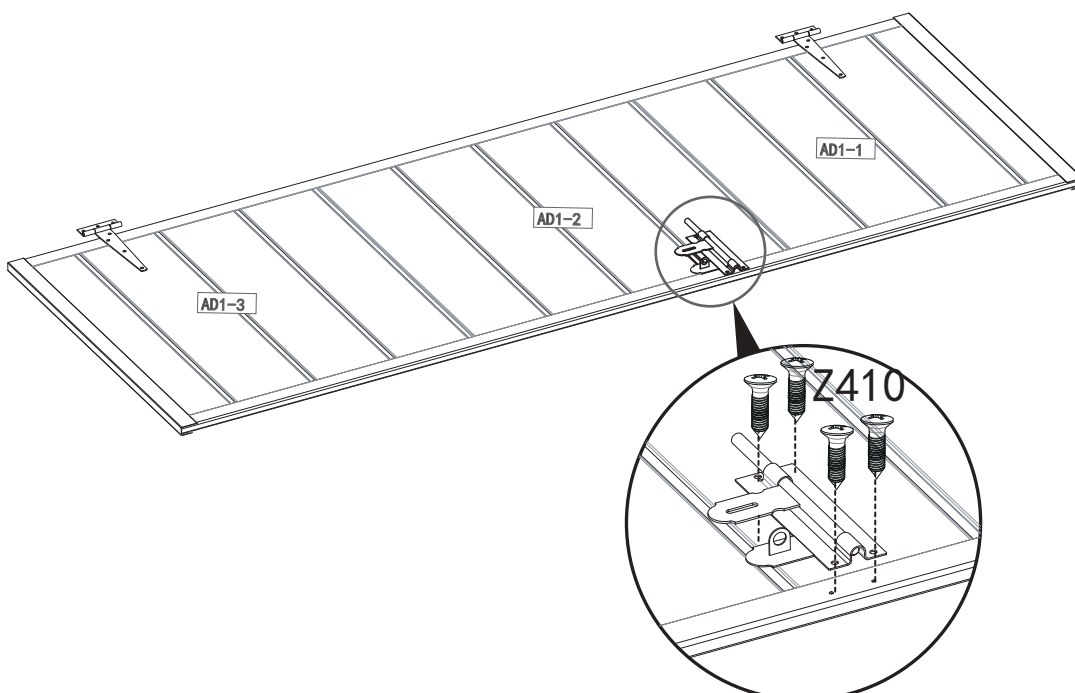

Z410



4 PC

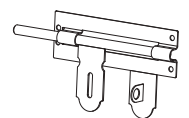

Step 50

Z410



10 PC

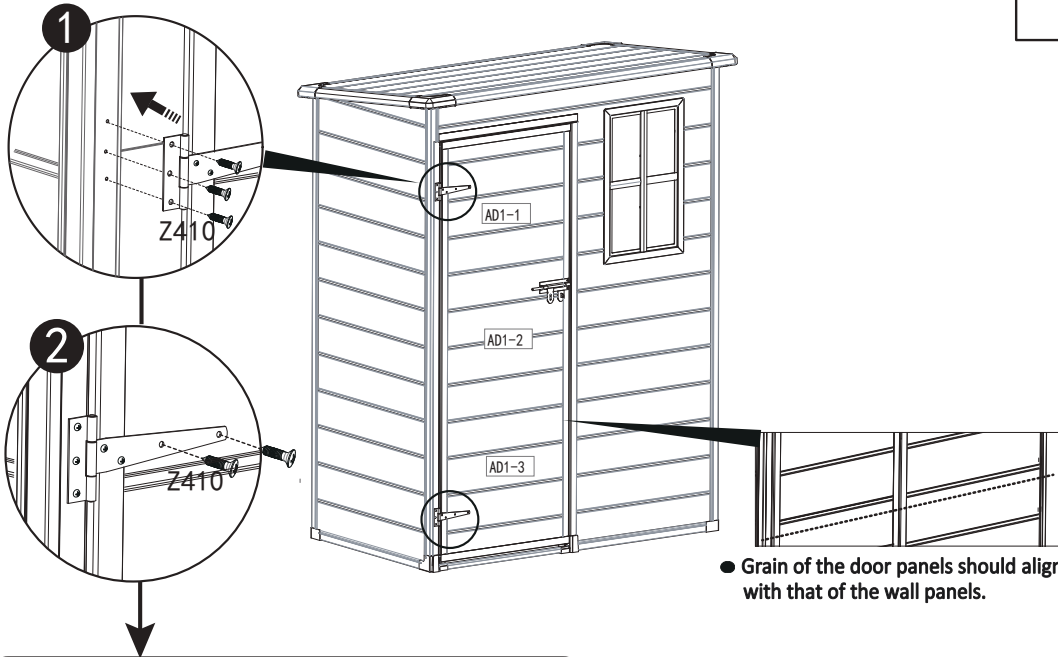

Nail the door after place adjustment and fasten all the screws.

Step 51

M04



1 PC



ZW413

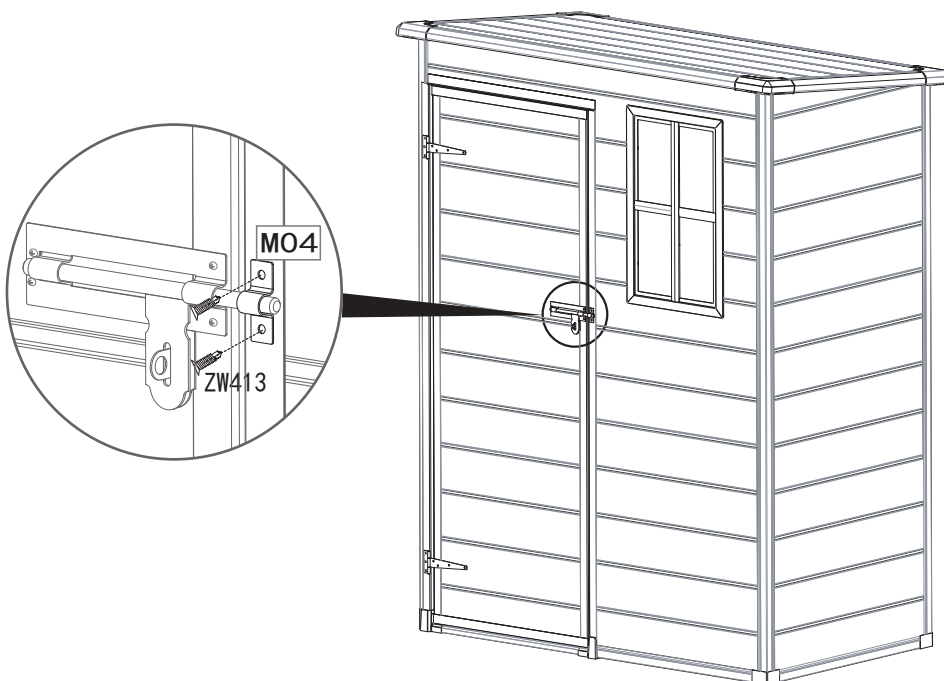

2 PC

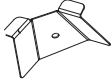

Step 52

SG14	SG15	Z410
 2 PC	 2 PC	 4 PC

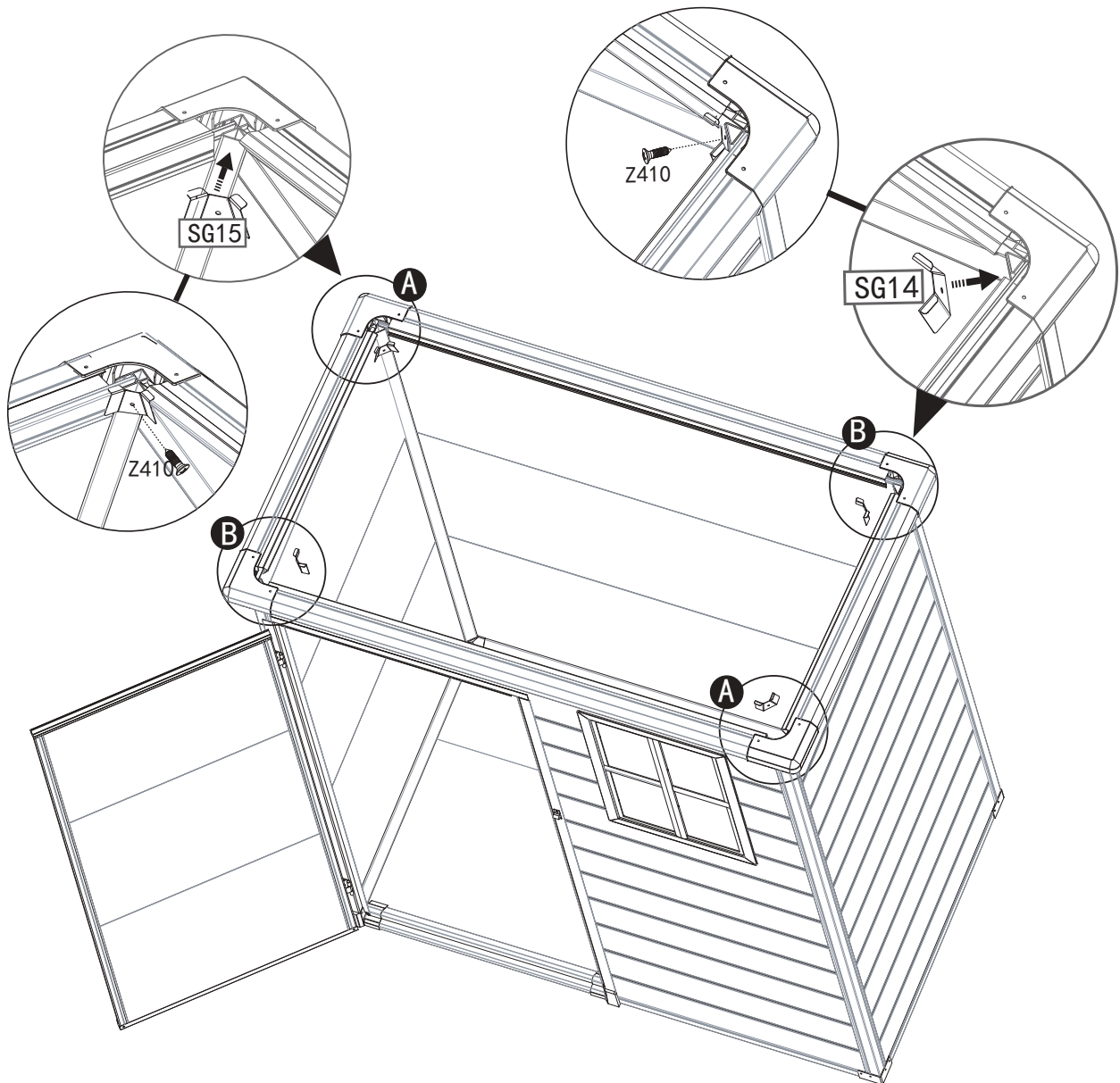

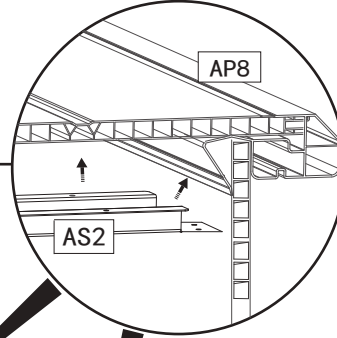
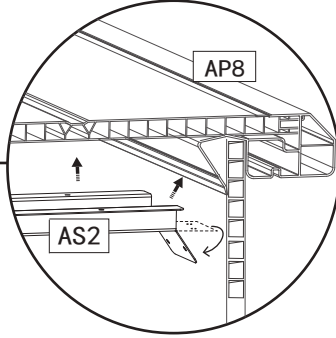
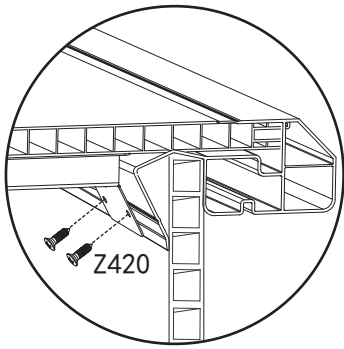

Step 53

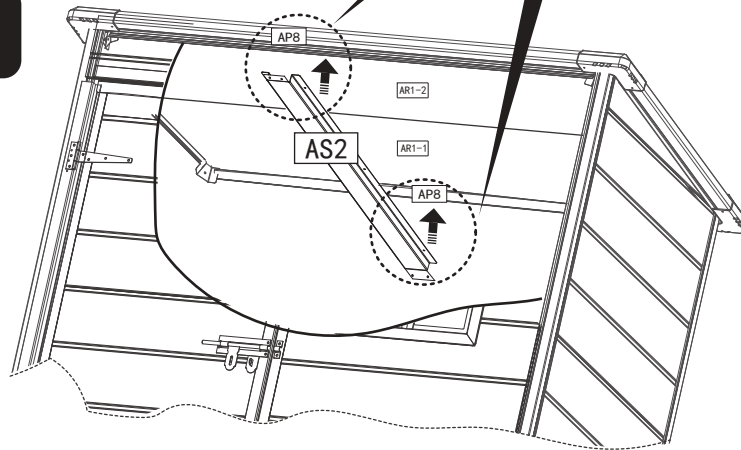

1

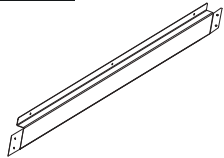

AS2		1 PC
Z410		6 PC
Z420		4 PC

2

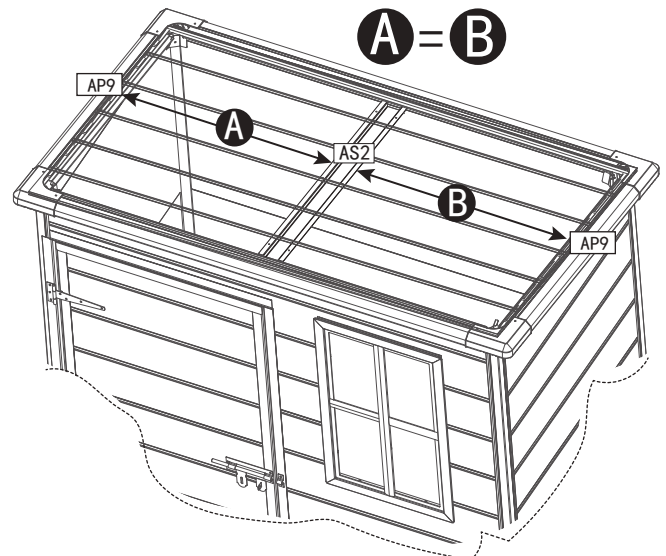
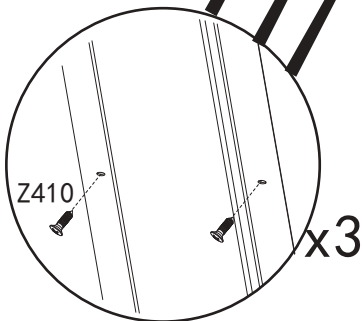
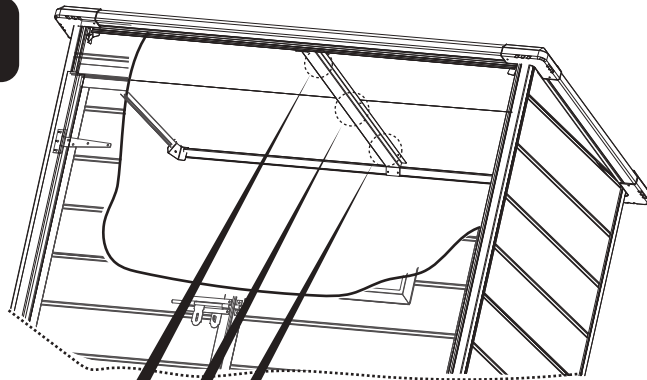

PARTS SCHEMATIC

