

GALAXY TRACKER® 60 SMART TELESCOPE Item no. 23031, 23032

60 POWER 50MM ASTRONOMICAL TERRESTRIAL TELESCOPE (23031)

60 POWER 50MM ASTRONOMICAL TELESCOPE (23032)

HOW TO USE ASTRONOMICAL TERRESTRIAL TELESCOPE

COMPONENTS OF THE TELESCOPE

- 1 OBJECTIVE LENS LID
- 2 OBJECTIVE LENS
- 3 LENS HOOD
- 4 TELESCOPE TUBE
- 5 BRACKET
- 6 KNOB BOLT
- 7 TRIPOD LEGS
- 8 FOCUSING TUBE HOLDER
- 9 FOCUSING TUBE
- 10 EYEPIECE
- 11 EYEPIECE LID
- 12 FOCUSING KNOB
- 13 DIAGONAL MIRROR
- 14 ERECTING EYEPIECE /21X MICROSCOPE *
- 15 OCULAR OF ERECTING EYEPIECE *

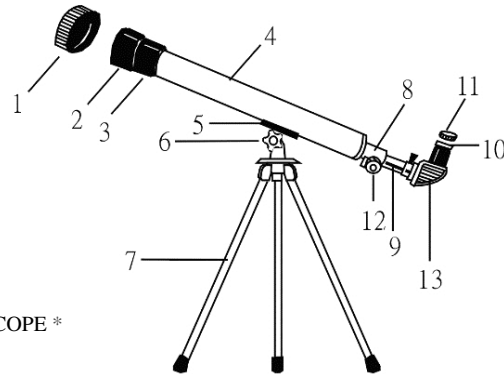

(* Only applicable to item no. 23031)

HELPFUL HINTS FOR SETTING UP YOUR TELESCOPE

- 1) Unpack the tripod from the box. Next, stand the tripod up vertically by dragging the leg extension and spread the legs apart fully.
- 2) Slide the telescope bracket (5) and adjust the holes.
- 3) Remove the lens lids (11 & 1) from the eyepiece and the objective lens (10 & 2).

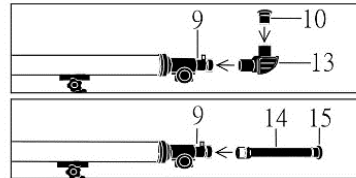

OBSERVING ASTRONOMICAL OBJECTS THROUGH YOUR TELESCOPE

- 1) Glance through the main telescope's eyepiece (10) for your object. (Note: You may have to alter the angle of the telescope slightly.) The object will most likely seem to be blurry at this stage, but that is normal. You are just trying to get the object in the viewing field of your telescope lens. Once you have accomplished this task, fasten the knob bolt (6) to keep the accuracy of your telescope steady.
- 2) Now adjust the focusing tube (9) by turning the focusing knob (12) slowly back and forth until the blurred object becomes precise.
- 3) If you are going to be looking through the telescope for a short period of time, you can insert the eyepiece (10) directly into the focusing tube (9). To be more comfortable when using your telescope for longer periods of time, place the diagonal mirror (13) into the focusing tube (9) and the eyepiece (10) into the diagonal mirror.

VIEWING TERRESTRIAL OBJECTS THROUGH YOUR TELESCOPE (Only applicable to item no. 23031)

For viewing terrestrial objects, remove the diagonal mirror (13) and the eyepiece (10) from the focusing tube (9). Insert the erecting eyepiece (14) into the focusing tube (9). The erecting eyepiece can also be used as a 21x microscope by placing the objective end (the end with the transparent tube) flat on an object and looking through the eyepiece.

DO NOT VIEW SUN THROUGH TELESCOPES SERIOUS INJURY TO EYE MAY RESULT

COMPONENTS OF THE SMARTPHONE ADAPTOR

- 1 ADJUSTABLE ARM
- 2 SMARTPHONE HOLDER
- 3 BRACKET
- 4 QUICK RELEASE LEVER
- 5 ARC
- 6 SMALL KNOB
- 7 LARGE KNOB

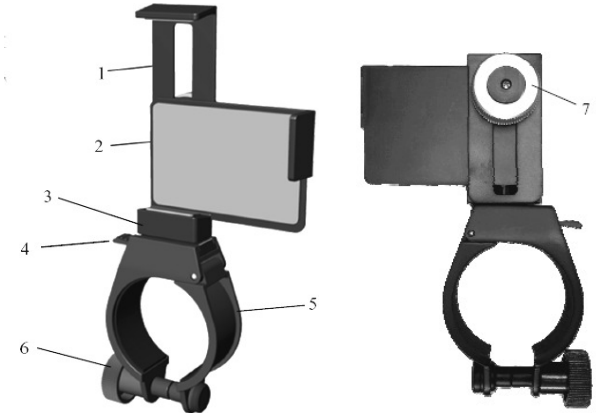

SETTING UP AND REMOVING THE SMART PHONE ADAPTER

Conventional methods which help identify and locate the celestial objects often trouble the novice users either by cost or manual labor. A new, convenient and accurate way is to utilize the smartphone software application.

To aid in using the software application, you have a smartphone adaptor to secure your smartphone onto the telescope. Thus, your smartphone and telescope can be moved and adjusted together to locate the celestial objects with your desired angle and direction.

To place your smart phone on the adaptor and remove it after use, follow these directions:

Attach the smartphone to the holder:



- 1) Loosen the large knob at the back of the adaptor and put the smartphone on it with face up.
- 2) Adjust the position of the horizontal arm to fit the width of the smartphone and tighten the large knob so that the smartphone is securely held in place.

Attach the telescope clip to the telescope tube:

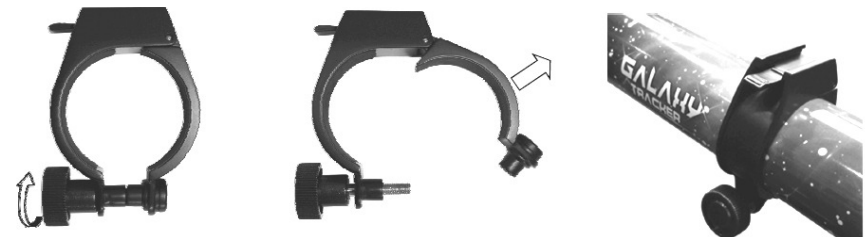

- 3) Loosen the small knob on the base of the clip.
- 4) Open the arc of the ring.
- 5) Attach clip to the telescope tube with the flat side in upper position.

6) Close the ring, secure by tightening the small knob.

Attach the smartphone to and remove it from the telescope:

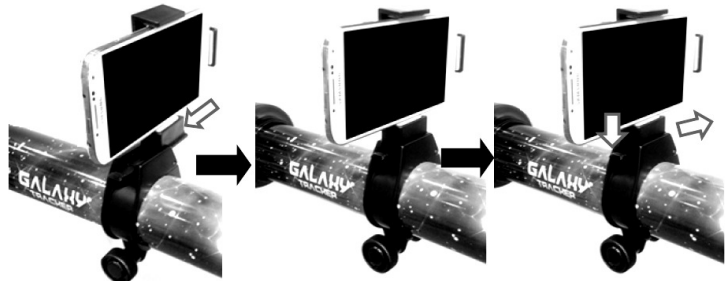

7) Slide the smartphone adapter to the telescope clip.

8) Press the quick release lever and slide the smartphone adaptor out.

USING STAR WALK™ 2

A stargazing smartphone software application (e.g. Star Walk™ 2 for iOS and Android) helps you find and identify the celestial objects easily.

Select “Take a Tour” (Menu  → Take a tour) to familiarize yourself with the various app features. The App language will follow your smartphone’s language setting.

Features Highlight:

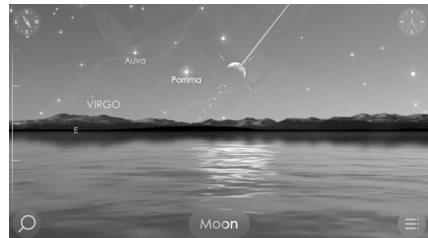

IDENTIFY THE CELESTIAL OBJECTS

After the smartphone adapter is attached to the telescope, the smartphone orientation is aligned with the telescope. Utilizing the smartphone’s location, orientation and time information, a star map application can show the real time simulated sky view on the screen matching the view through the telescope. Names of the stars or celestial objects are shown on screen. The information of the screen is automatically updated when users adjust the telescope or move the telescope to a different location.

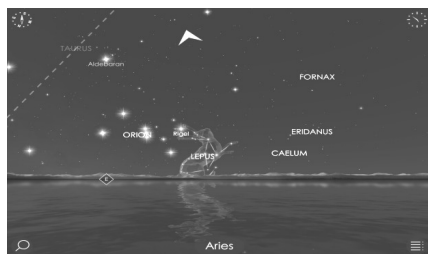

SEARCH AND DIRECT

Another advantage of using the application software is that users can search for a celestial object. The screen will guide users which direction to move the telescope.

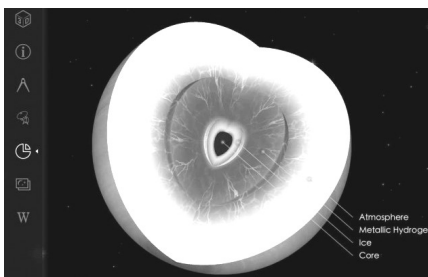

INFORMATION OF THE CELESTIAL OBJECTS

Users can select the objects on the screen to read detailed information like their internal structures, orbits and compositions.

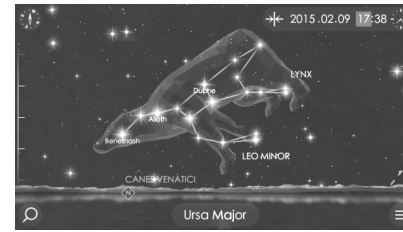

TIME MACHINE

Besides the real-time star map, users can extend the control of star viewing into the past and future. Users can see how specific celestial events unfold through the change of time.

HOW MUCH POWER: CHOOSING THE EYE LENS

Power refers to the ability of a telescope to enlarge an image, or, in effect, bring it closer to the viewer. Amount of magnifying power is signified by a number followed by an X (read "power"). So if you view an object at 25X, you are seeing it as if you are 25 times closer to that object.

Power is calculated by dividing the focal length of your telescope’s objective lens (probably indicated on the focus tube) by the focal length of the eye lens you select. The focal length of the eye lens is usually indicated on the eyepiece itself (e.g., 4mm, 10mm, 20mm etc.)

| | |
|----------|--|
| Example: | $\frac{500\text{mm (focal length of objectives lens)}}{20\text{mm (focal length of eyepiece)}} = 25\text{X (power)}$ |
|----------|--|

The longer the focal length of the eyepiece, the less the magnifying power of the telescope; the shorter the focal length, the greater the power. So when you select an eye lens to insert into the diagonal prism, you're really choosing what magnifying power you wish to use for observation.

CARE OF YOUR TELESCOPE

Your telescope should be kept away from dust and moisture. If the lenses get dirty, blow any dust particles off before cleaning. Clean the lenses with a moistened lens tissue. Always store your telescope in the box when not in use.