

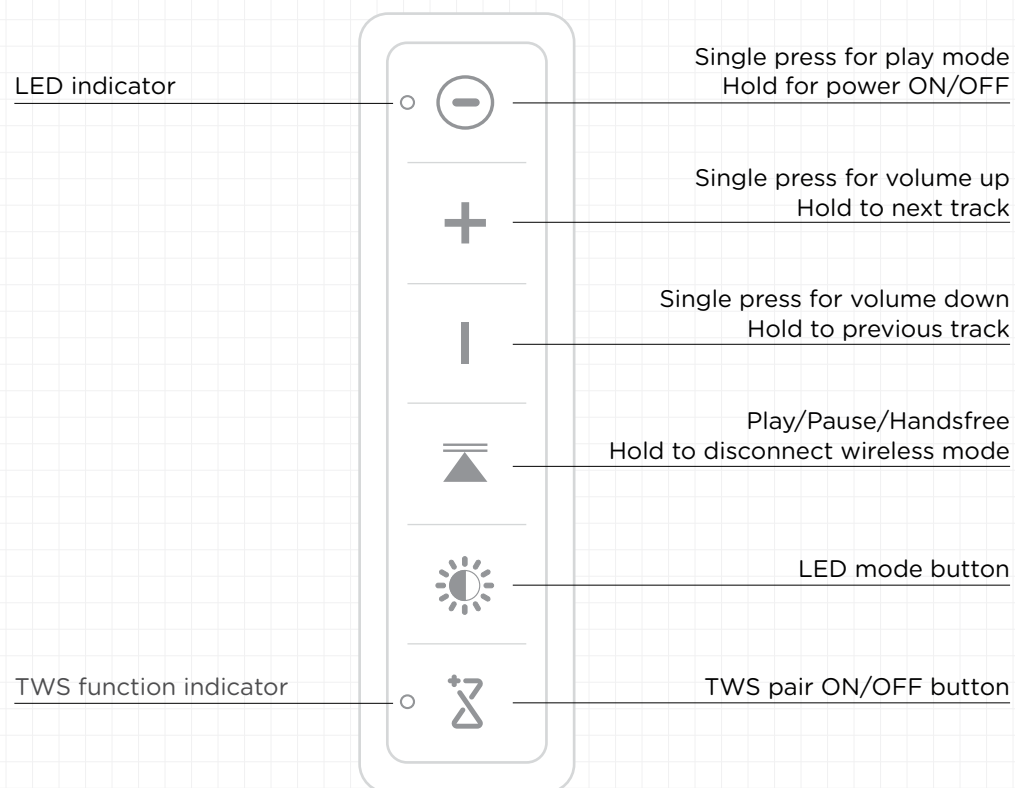

Street Party

Wireless Speakers + TWS

CONTROL PANEL



LED INDICATOR

Speed	Colour	Action
Rapid flash	White	Wireless mode searching
Slow flash	White	Wireless pairing successful
Solid	White	Line in mode
Solid	White	USB playing

BACK OF SPEAKER OVERVIEW

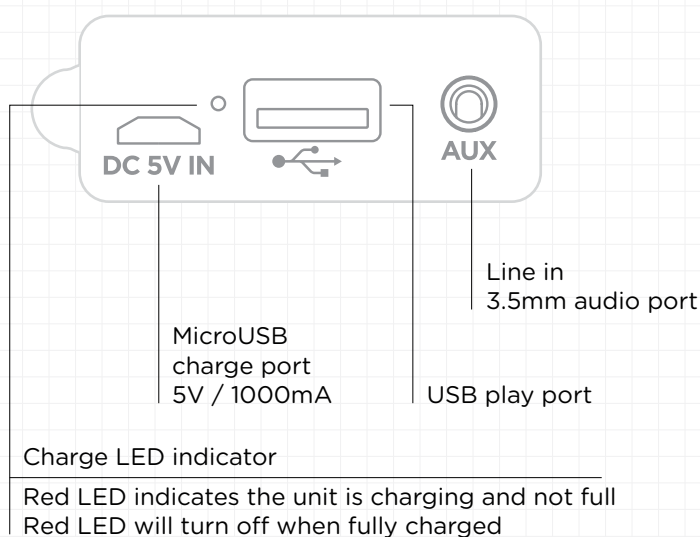

CHARGING

Use the *included MicroUSB to USB charging cable* and plug the MicroUSB end into the DC 5V port located on the back of the unit.

The battery is fully charged in 6.5 hours. Charge time will be longer if speaker is being used during charging.

The red LED light indicates that the unit is charging. The red LED will turn off when the battery is fully charged. The charge cable can then be disconnected.

PLAY MODE

Auxillary Play Mode

1. Hold the **(i)** button to turn on the speaker.
2. Connect one end of the audio cable (not supplied) to the 3.5mm audio port at the back of the speaker (see *Back of Speaker Overview*)
3. Connect the other end of the audio cable to the audio source.
4. Speaker will go to auxillary mode automatically (LED will glow solid white)

Wireless Play Mode

1. When using a wireless enabled audio device, make sure the distance to the speaker is within 10m. Certain environments may affect the working distance.
2. Hold the **(i)** button to turn on the speaker. The unit will give a beeping sound to indicate it is in wireless pairing mode. The LED will rapidly flash white.
3. Turn on wireless mode on your play device.
4. Search for new device "Moki Block Party". No password will be required. If your device requires password, use "0000".
5. Adjust the volume on your audio device to the desired level.

Note: The speaker will automatically power off after 30 mins if not in use or music not being played.

USB Play Mode

1. Hold the **(i)** button to turn on the speaker.
2. Plug your USB / flash drive into the USB-A port on the speaker.
3. The unit will enter USB play mode automatically.

LED MODE SELECTION OVERVIEW

Press **☀** button to cycle through different LED modes.
 Hold **☀** button to turn off top and bottom light.
 Hold **☀** button to turn off center light.
 Double press **☀** button to turn on/off side flashing lights.

TWS CONNECTION

Two speakers can be synced and connected via TWS (True Wireless Stereo) Technology.

1. Hold the **(i)** button on each speaker to turn both speakers on.
2. Press and hold the **🔗** on both speakers to enter TWS mode.
3. You will hear a beep when the two speakers are paired (10 sec)
4. The LED on the master speaker will be solid white, while the LED on the second speaker will flash white.
5. On your audio device, turn wireless mode on and follow normal wireless pairing instructions.

Note: Once speakers have been paired via TWS, they will pair again each time they are turned on. If you want to unpair them, press the **🔗** to disconnect.
 The speaker will beep and both LEDs will flash indicating the speakers are no longer paired.

TROUBLESHOOTING

Issue	Possible Solution
No power	• Make sure your speaker is turned on and make sure your speaker is completely charged.
No sound	• Make sure the volume of your speaker is not at the lowest setting. • Make sure the connected audio device is playing audio.
Sound is distorted	• Turn down the volume of the speaker or the connected device.
Cannot pair with my play device	• Make sure wireless mode on your device is turned on. • Your wireless device may be out of range. Try moving it closer to the speaker. • Move your wireless device and/or speaker away from other devices that generate electromagnetic interference, such as phones, microwave ovens, wireless network routers, or other wireless devices.

BATTERY HEALTH

To prevent the possibility of the battery from leaking, heating or catching fire, please follow these precautions:

Warnings

- Please use supplied USB charging cable to charge speaker.
- Please disconnect charge cable after speaker is fully charged.
- Do not continue to charge speaker after it is fully charged.
- Do not use or leave the speaker near a heat source such as a fire or a heater.
- Do not place speaker in any liquid, fire or on a heater.
- Do not hit or throw the speaker.

Cautions

- Do not use or leave speaker in very high temperatures (ie. in direct sunlight or in a vehicle in extremely hot conditions)
- Do not use speaker where there is a lot of static electricity, otherwise the safety devices within the speaker can be damaged.
- The speaker should be stored at room temperature.
- The speaker battery should be charged and discharged every so often in order to activate and restore the battery's energy.
- Please follow battery waste recycling guidelines when disposing of the speaker.

E-WASTE

This product bears the selective sorting symbol for waste electrical and electronic equipment (WEEE).

This means that this product must be handled according to the European Directive 2002/96/EC in order to be recycled or dismantled to minimize its impact on the environment. For further information, please contact your local or regional authorities.

Should you need to dispose of this product, please note that electrical products should not be disposed of with household waste. Please dispose of speaker thoughtfully.

SCAN THIS CODE

Visit our website for more information about this, and many other great products.