

9

8

7

6

5

4

3

2

1

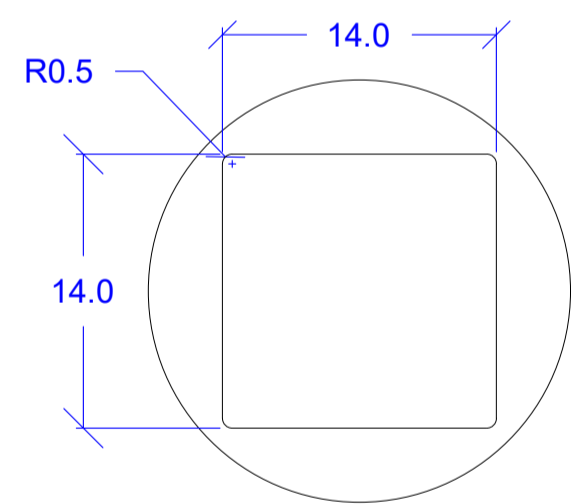
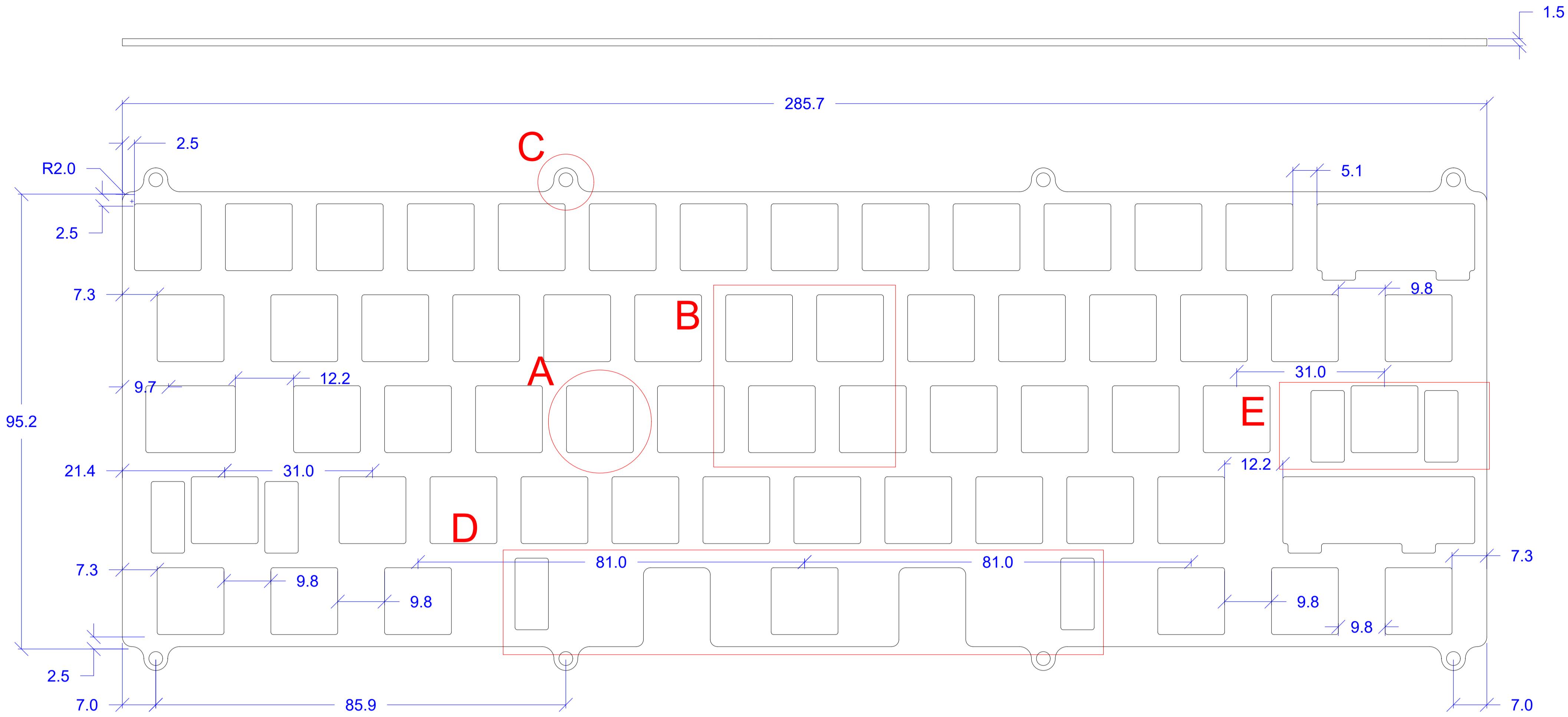

DETAIL A

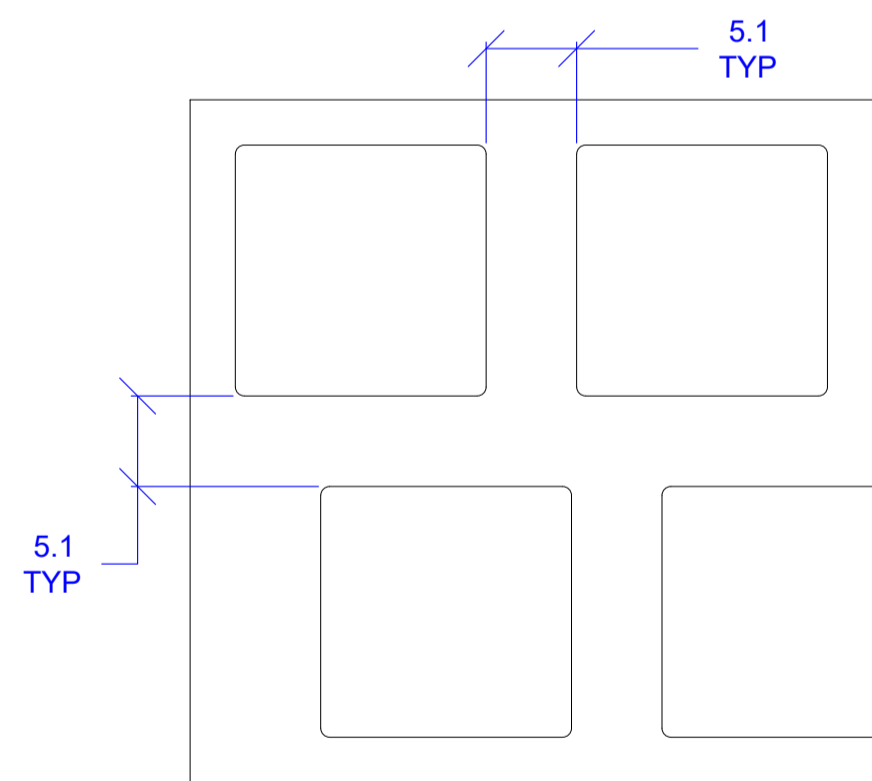

DETAIL B

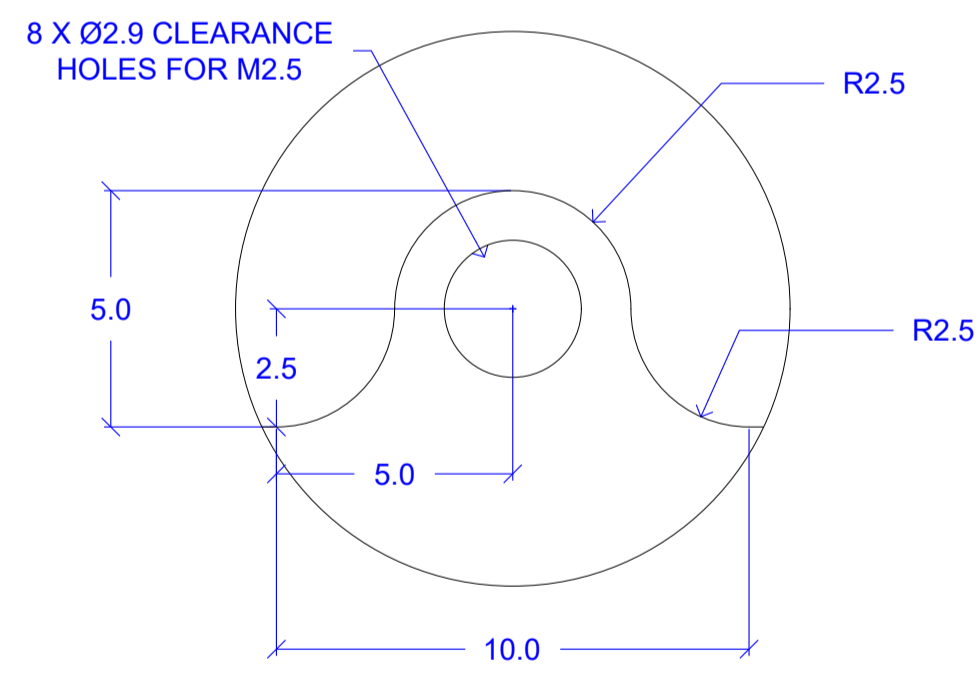

DETAIL C

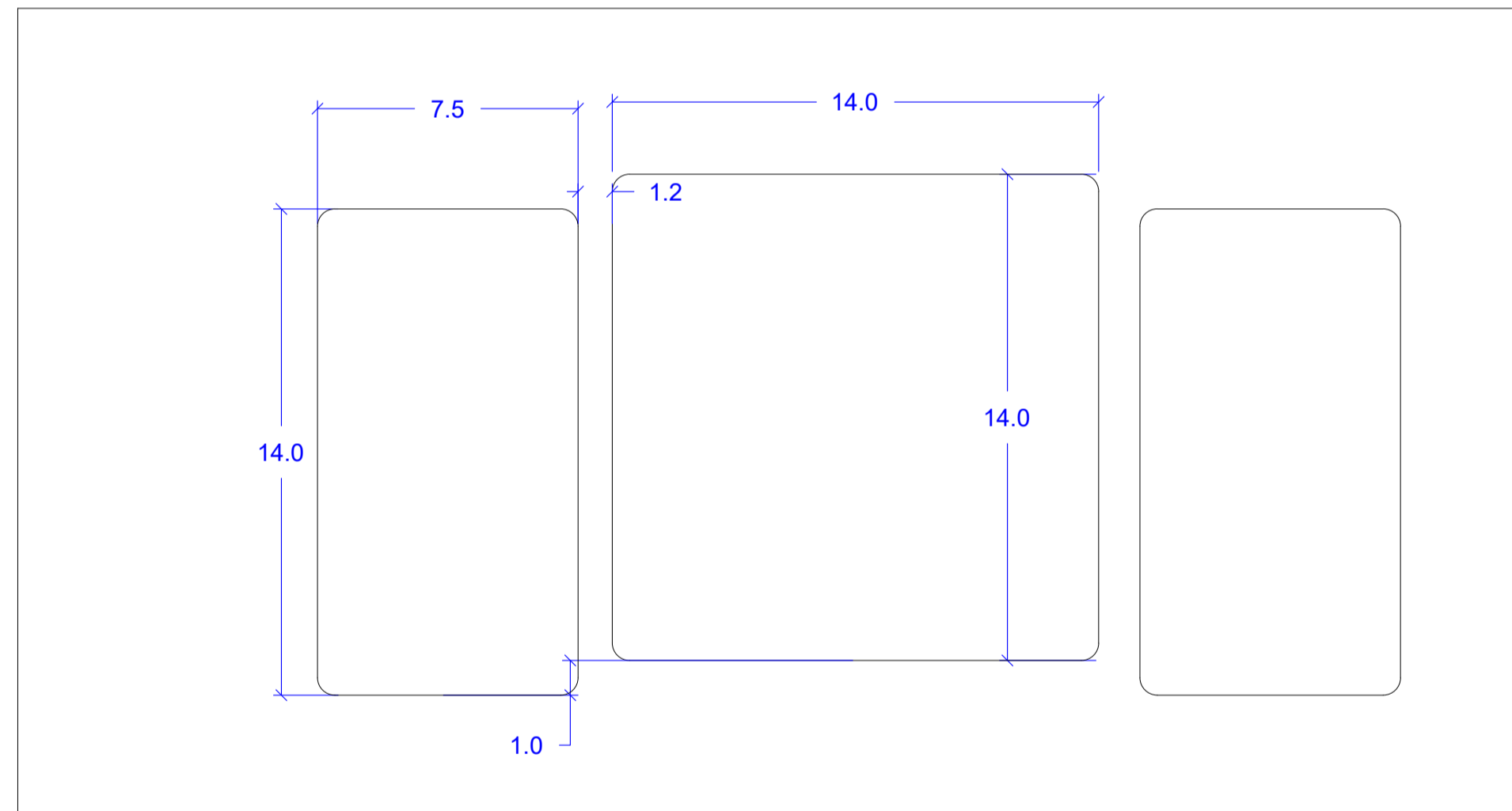

DETAIL E

**FOR  
MANUFACTURE**

GENERAL NOTES:

1. MATERIAL: 1.5mm ALUMINIUM 6063
2. SURFACE: STANDARD MILL FINISH
3. FINISH: ANODIZED
4. DEBURR: DEBURR AND BREAK ALL SHARP EDGES
5. FIXTURES: HEX HEAD SCREWS

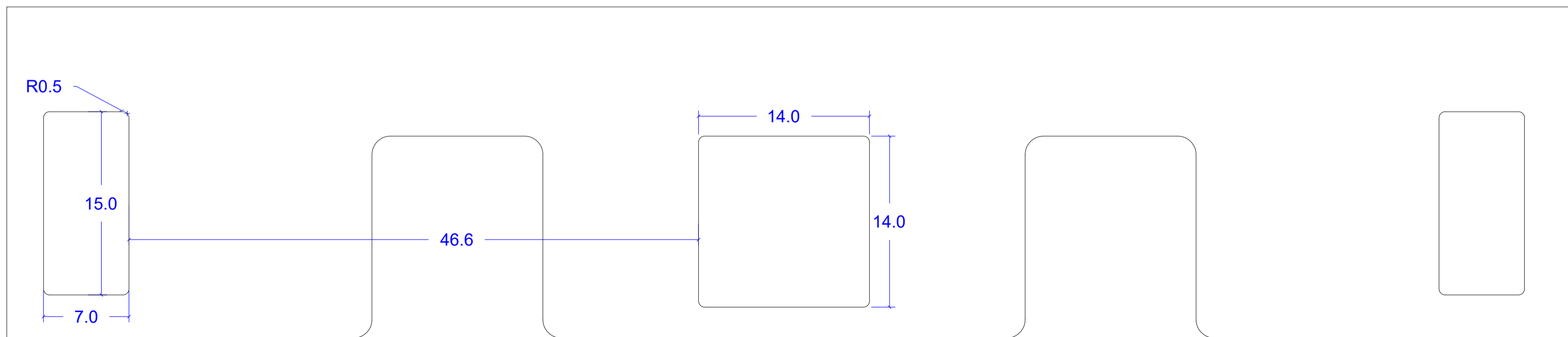

DETAIL D

			<b>HongHobbies</b> honghobbies@outlook.com	
B	24-JUL-2021	ISSUE FOR MANUFACTURE	DRAWING NUMBER:	REV:
A	15-APR-2021	FIRST ISSUE FOR CO-ORDINATION	<b>HH60-P-005</b>	<b>B</b>
ISSUE	DATE	DESCRIPTION	PART NUMBER:	
DESIGNED	ALL DIMENSIONS IN MILLIMETERS		PART NUMBER:	
EH	Tolerance Specifications: (UNLESS NOTIFIED OTHERWISE)		<b>HH60-P-005</b>	
MATERIAL:	NO DECIMAL PLACES ±0.50		PART NAME/DESCRIPTION:	
1.5mm ALUMINIUM 6063	1 DECIMAL PLACES ±0.10		<b>HH60 TSANGAN PLATE</b>	
FINISH:	2 DECIMAL PLACES ±0.05			
ANODIZED	ANGULAR ±0.5°			
QTY: 1	SHEET SIZE: A1	SCALE: NTS	WEIGHT: 0.056KG	SHEET: 1 OF 1

9

8

7

6

5

4