



Datasheet MVEC167

IP67 industrial camera enclosure for the protection of machine vision camera and lens from water and dust. No special cables needed.

General

Series	MVEC
Product name	MVEC167
Device application	Machine vision camera enclosure
Height	55.8mm
Width	53.5mm
Depth	148.8mm
Max. camera size (HxW)	29x29mm
Max. lens size diameter	40mm
Max. lens size length	105mm
Required data cable diameter (for IP67)	GeT Cameras GigE cable or USB3 cable with sleeve Cable diameter 6.5mm +/- 0,1mm
Required I/O cable diameter (for IP67)	GeT Cameras I/O cable / cable diameter 4.8mm +/- 0.1mm
Enclosure mounting	Tripod & 4xM5
Device composition	<ol style="list-style-type: none"> 1. mounting plate / heatsink 2. adapter plates 3. lens cover 4. lens tube extension rings (2 pcs. included) 5. body 6. Cable entry 7. I/O plug
Quantity	1 pcs.
Locking type lens tube	Bayonet mounting
Weight	90g

Material

Body	Industrial polymer
Lens cap shield	Aluminium
Adapter plates	Aluminium
Mounting plate	Aluminium
Seals	Rubber
I/O plug	Industrial polymer
Protective window	Gorilla glass

Complementary

Product certifications	Internal
Certifications	Reach, RoHS
IP degree of protection	IP67
Ambient air temperature for storage	-15 - 40 °C
Operating temperature (Mounted to metal surface)	0 – 45 °C
Operating temperature (Not mounted to metal surface)	0 – 35 °C

Mounting plates

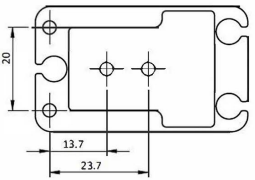
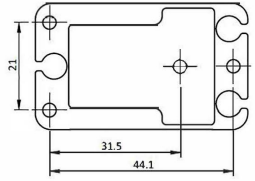
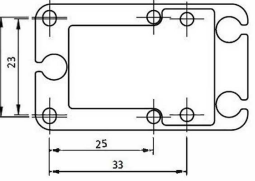
<p>1</p> 	<p>Daheng Imaging MER1 / MER2 USB3 Daheng Imaging MER1 / MER2 GigE also PoE Basler Ace Classic Basler Ace U Flir Blackfly USB3 Flir Blackfly GigE Flir Blackfly S USB3 (or mounting plate 3 depending on exact model) Flir Blackfly S GigE (or mounting plate 3 depending on exact model) AVT Mako U AVT Mako G AVT Alvium U Jai Go Jai Go-X Other camera models that are 29x29mm and match the mounting patter</p>
<p>2</p> 	<p>Basler Ace 2 Basic Baslar Ace 2 Pro Other camera models that are 29x29mm and match the mounting patter</p>
<p>3</p> 	<p>Flir Blackfly S USB3 (or mounting plate 1 depending on exact model) Flir Blackfly S GigE (or mounting plate 1 depending on exact model) IDS UI-xxxxCP IDS U3-xxxxCP IDS GV-xxxxCP Other camera models that are 29x29mm and match the mounting pattern</p>

Technical drawing

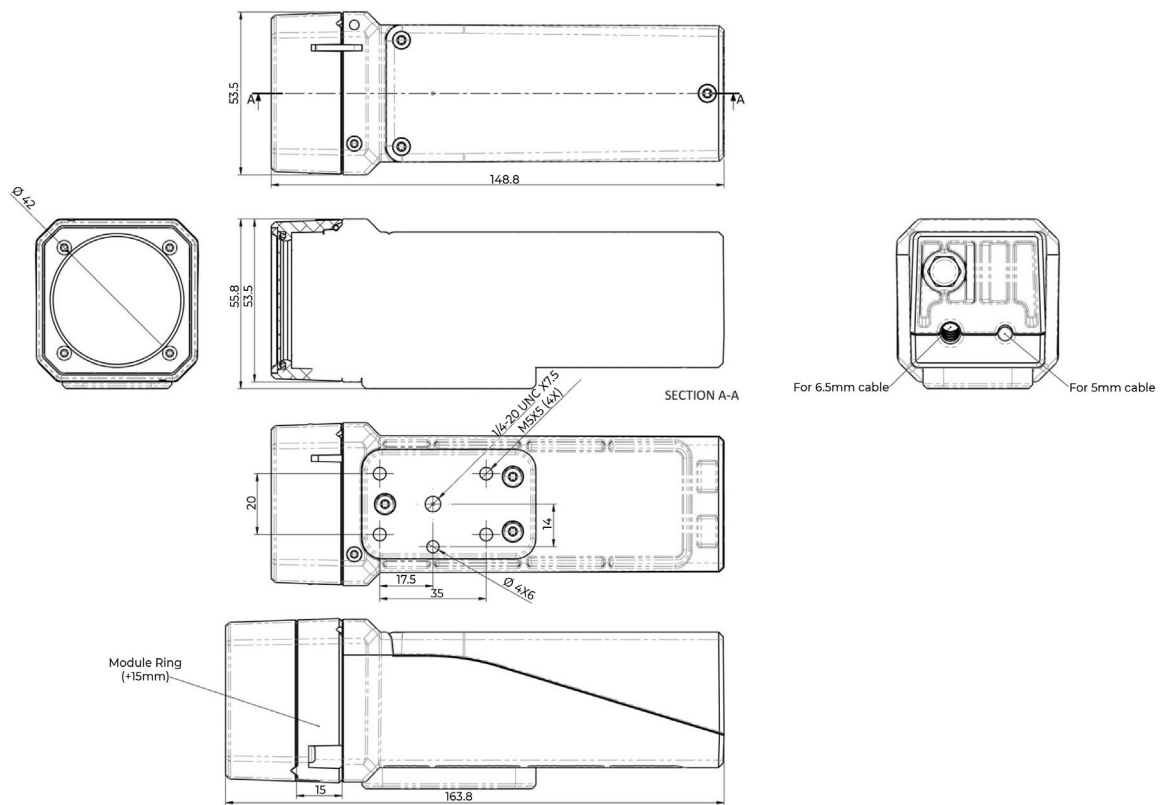

Cable mounting

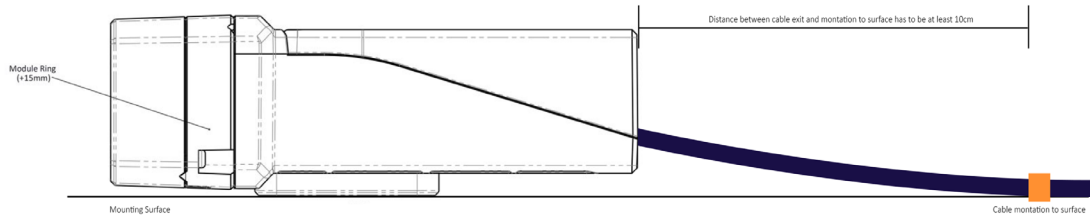

Minimal required distance cable before mounting to surface is 10cm. If the cable is under any kind of tension, the camera enclosure is no longer IP67.