

Classical

Leon

RECTANGLE DINING TABLE

MFL

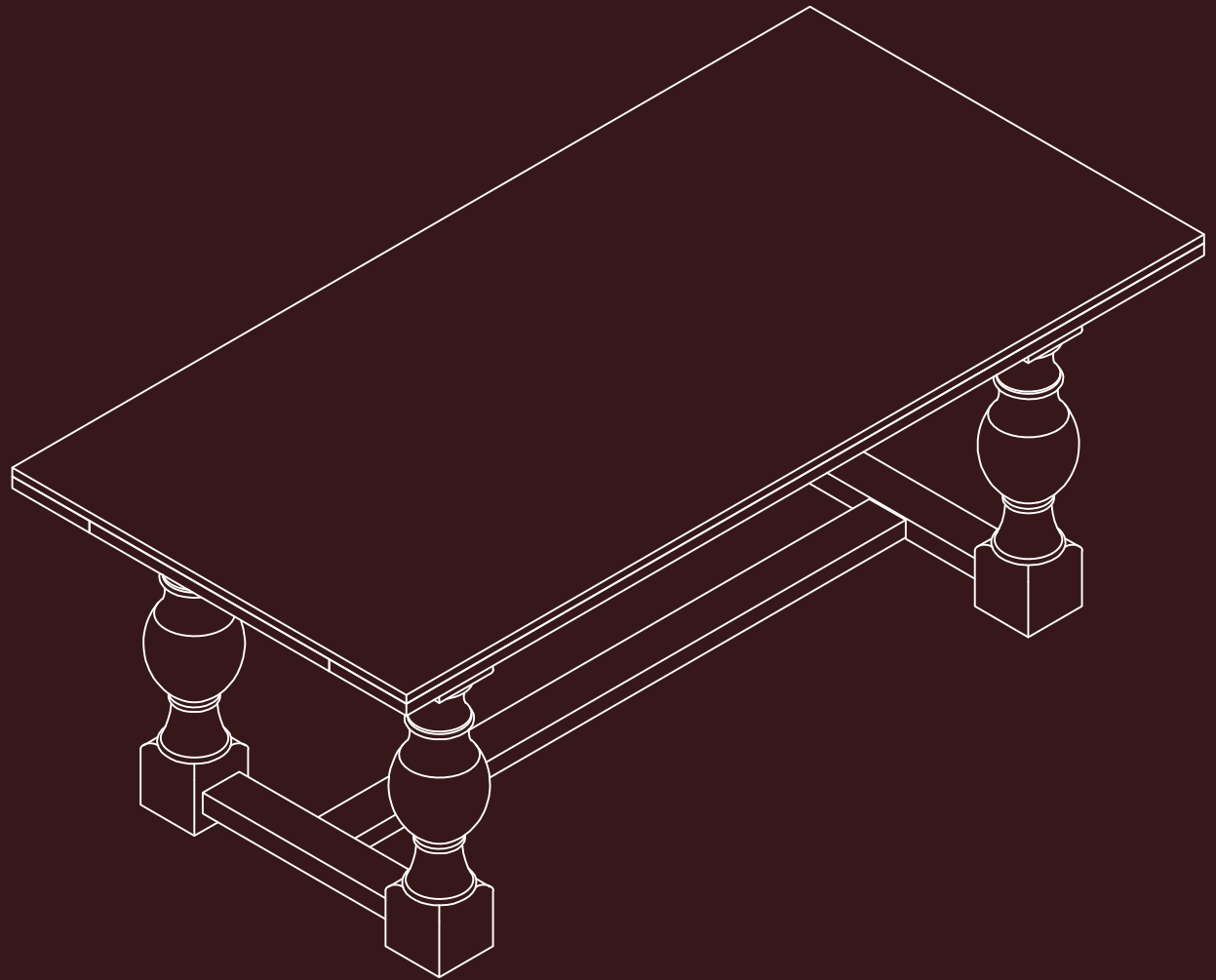

MAVENLANE.COM

 @mavenlanehome

Classical Leon Rectangle Dining Table



ABOUT US

As unique individuals, we all have our own ways of expressing ourselves. Through expression, we open doors to new opportunities and communicate to the world.

At Maven Lane, we understand the profound impact that home design can have on personal expression. Our homes serve as our nests, reflecting our individual styles, personalities, and values. They are the spaces where we create meaningful memories and moments of comfort and peace.

With this in mind, we set out to bring the finest in design, materials, and customer service directly to our customers, all at an attainable price point. Whether you're seeking to elevate your mornings with a cozy sanctuary or host laughter-filled dinners with loved ones, we are dedicated to helping you create a space that truly reflects who you are and what you aspire to be.

MAVENLANE.COM

 @mavenlanehome



CLASSICAL LEON RECTANGLE DINING TABLE

ASSEMBLY INSTRUCTIONS

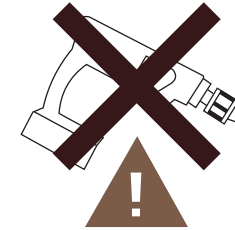
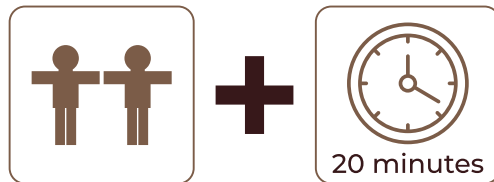
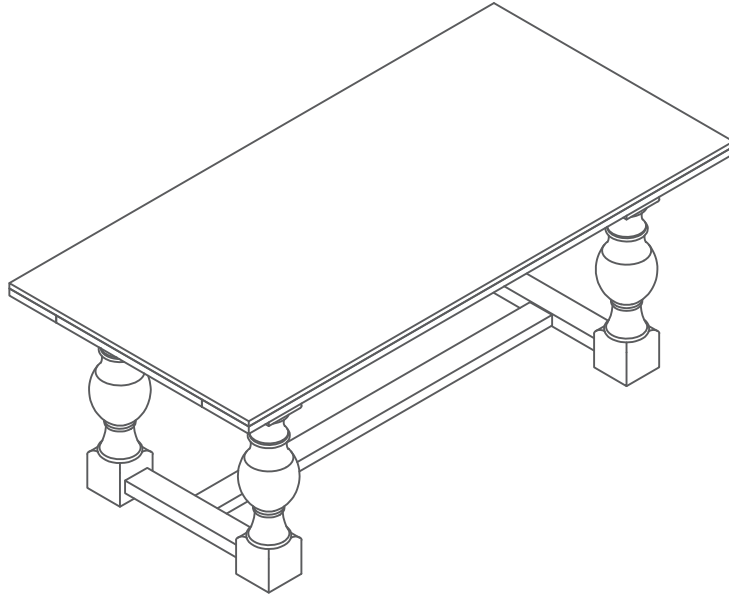

The use of power tools to assemble this product could lead to damage, making it unsafe

Please assemble on a clean, level surface to avoid damage and ensure proper assembly

Tools Required

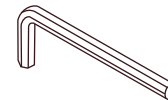

Allen Wrench
(included)

PARTS LIST

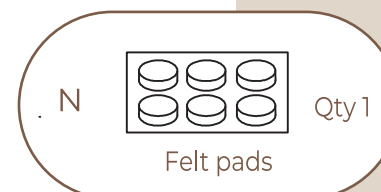
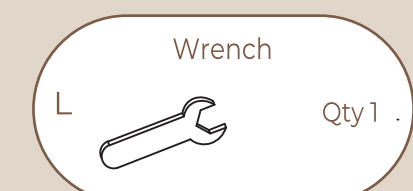
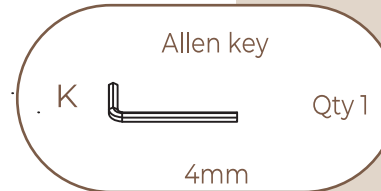
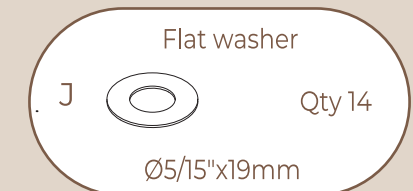
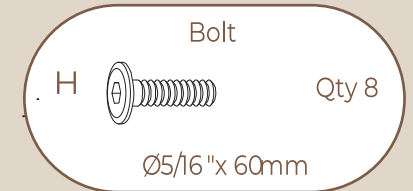
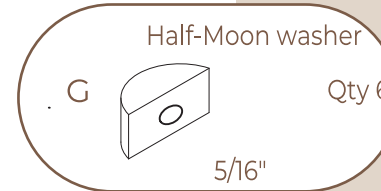
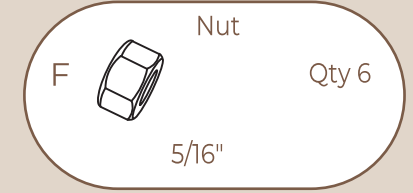
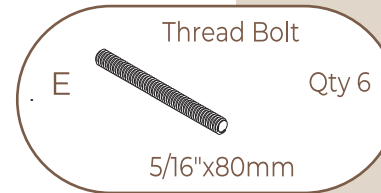
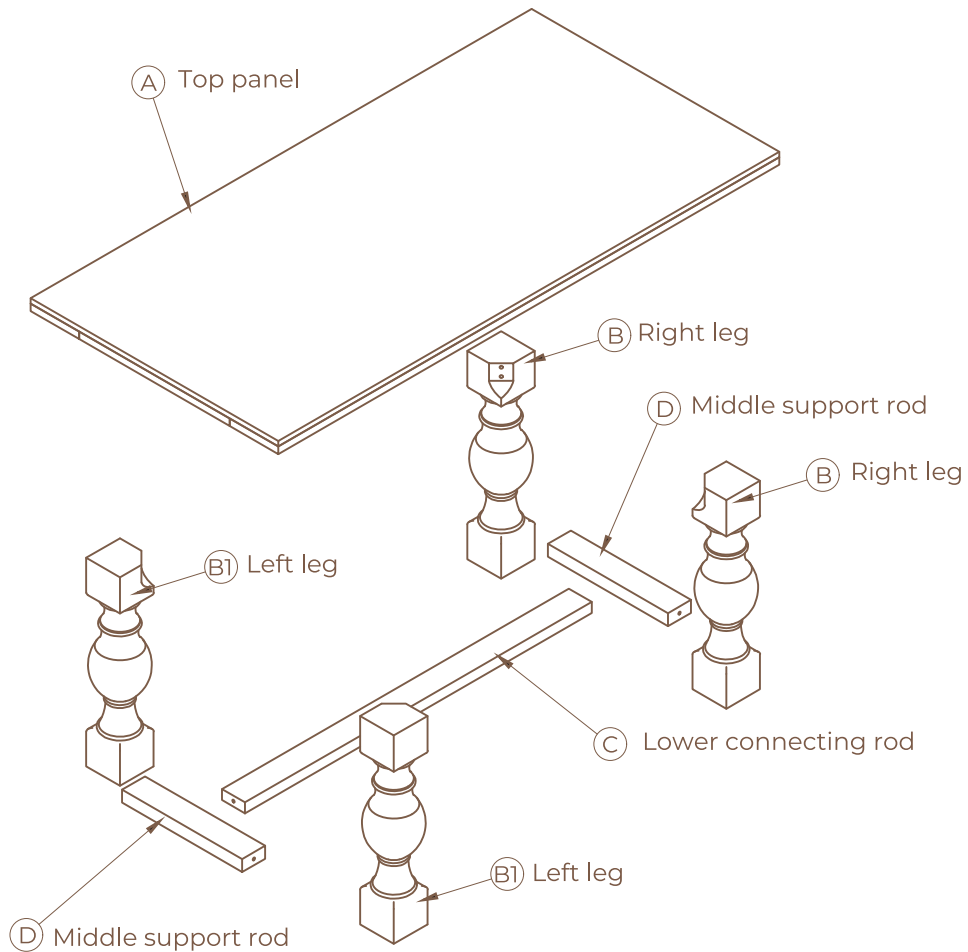

Scan for additional information



ASSEMBLY

STEP 1

Connect Middle Support Rods D to Right Legs B, using Wood Dowels M, Thread Bolts, E, Half-Moon Washers G, Flat Washers J, Lock Washers I, Nuts F, and Wrench L. Do not fully tighten yet.

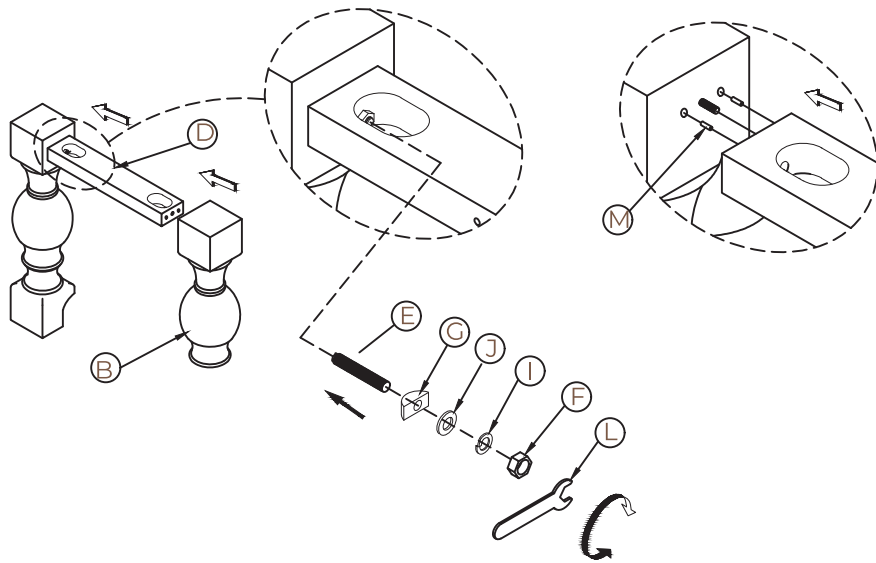

STEP 2

Insert the Right Legs B to Top Panel A with Bolts H, Lock Washers I, Flat Washers J using Allen Key K. Do not fully tighten yet.

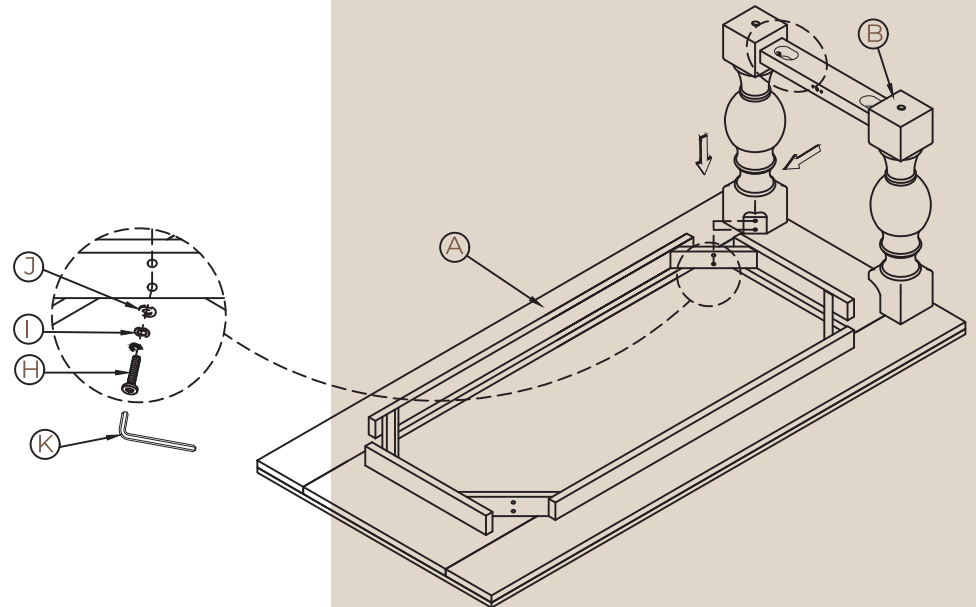

ASSEMBLY

STEP 3

Insert the Lower Connecting C to Middle Support Rods D using Wood Dowels M, Thread Bolts E, Half-Moon Washers G, Flat Washers J, Lock Washers I, Nuts F, and Wrench L.

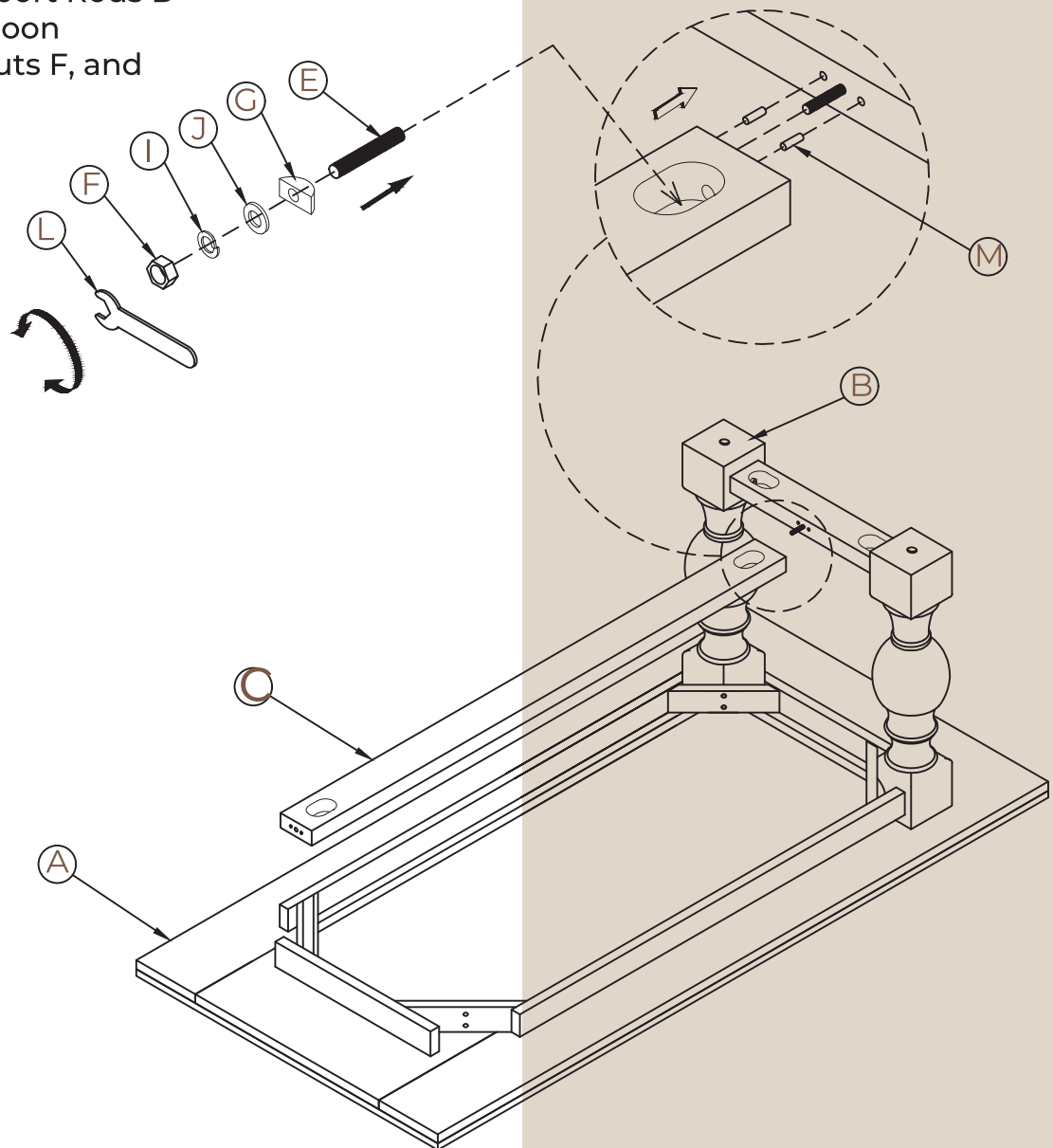

ASSEMBLY

STEP 4

Insert the Lower Connecting C to Middle Support rods D using Wood Dowels M, Thread Bolts E, Half-Moon Washers G, Flat Washers J, Lock Washers I, Nuts F, and Wrench L. Fully tighten all Nuts F from Steps 1, 3 and 4

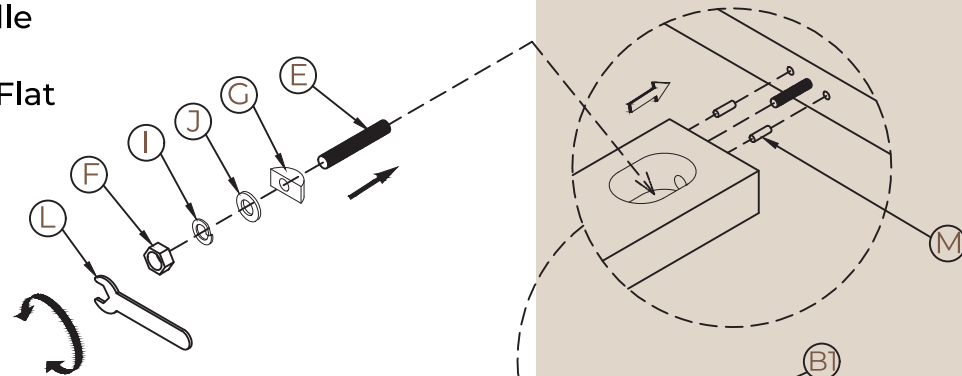

STEP 5

Insert the Left Legs B1 to Top Panel A with Bolts H, Lock Washers I, Flat Washers J using Allen Key K.

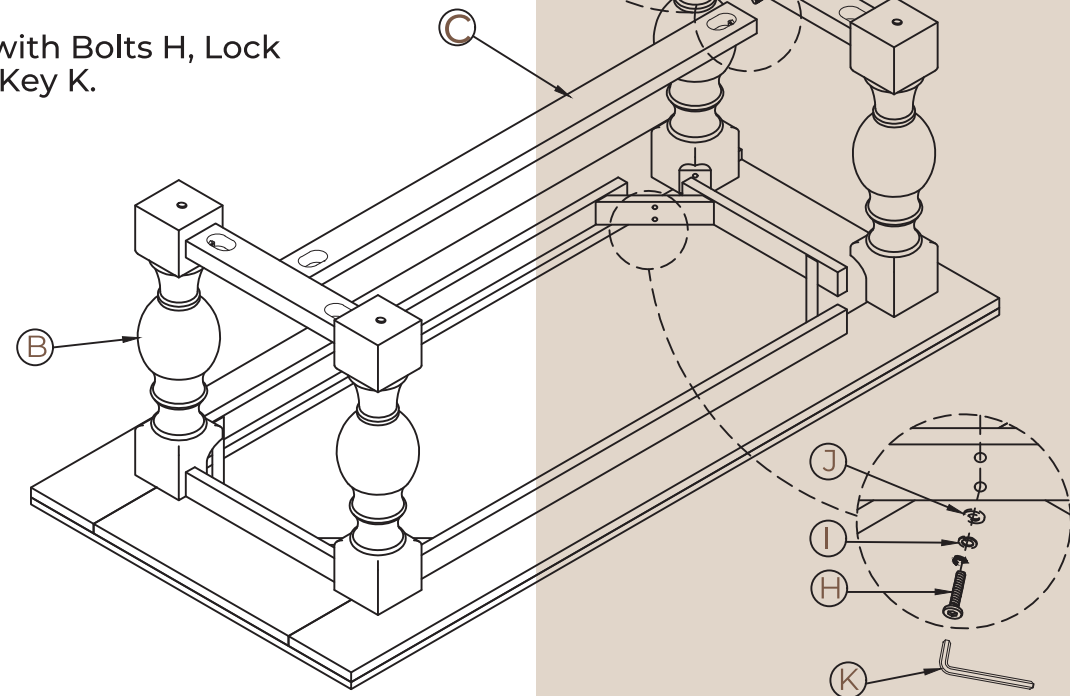

ASSEMBLY

STEP 6

Turn the table over on a flat, level surface. Fully tighten all Bolts H
Assembly complete

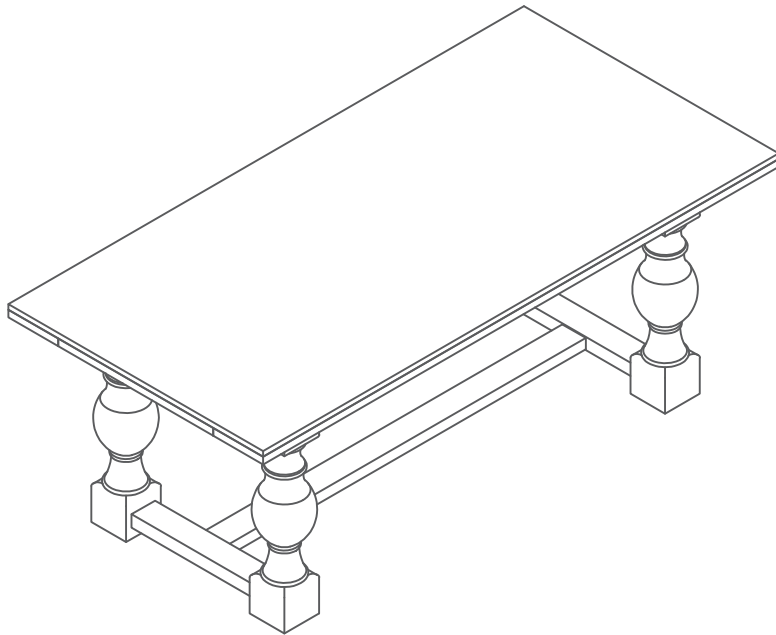

STEP 7: Felt Pad Application (optional)

1. Wipe any dust from the surface for best adhesion
2. Gently peel the felt pad from the paper
3. Firmly apply a felt pad to each of the feet

