

MFL

Contemporary
Celia
ROUND OTTOMAN

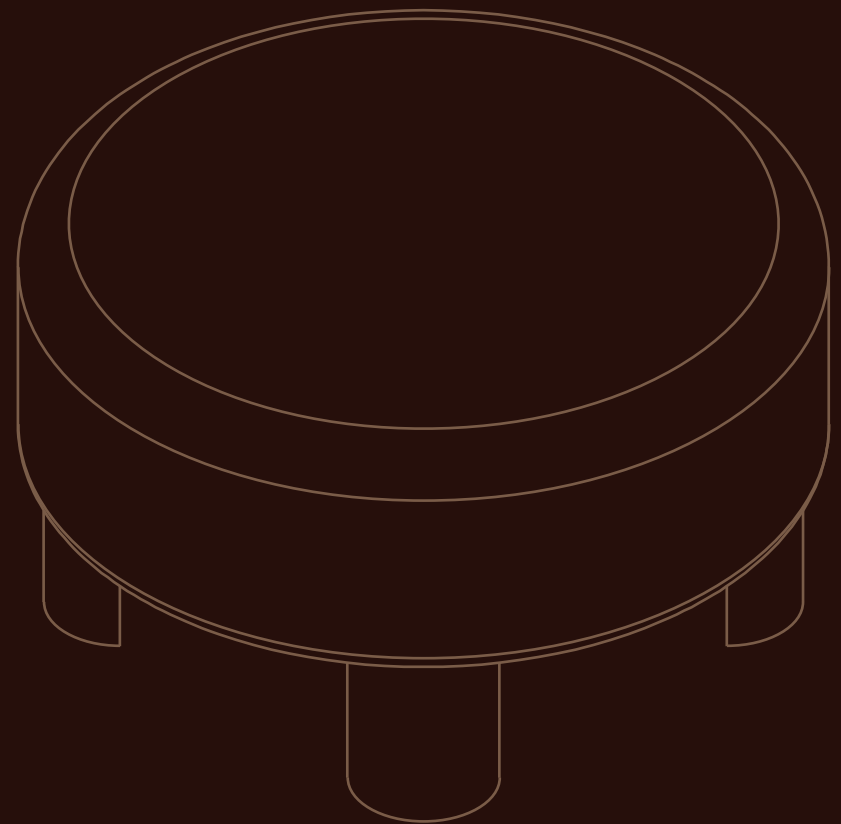

MAVENLANE.COM
 @mavenlanehome

Contemporary Celia Round Ottoman



MAVEN LANE

ABOUT US

As unique individuals, we all have our own ways of expressing ourselves. Through expression, we open doors to new opportunities and communicate to the world.

At Maven Lane, we understand the profound impact that home design can have on personal expression. Our homes serve as our nests, reflecting our individual styles, personalities, and values. They are the spaces where we create meaningful memories and moments of comfort and peace.

With this in mind, we set out to bring the finest in design, materials, and customer service directly to our customers, all at an attainable price point. Whether you're seeking to elevate your mornings with a cozy sanctuary or host laughter-filled dinners with loved ones, we are dedicated to helping you create a space that truly reflects who you are and what you aspire to be.

MAVENLANE.COM

 @mavenlanehome



CONTEMPORARY CELIA ROUND OTTOMAN

ASSEMBLY INSTRUCTIONS

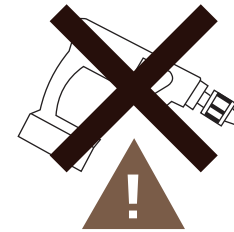
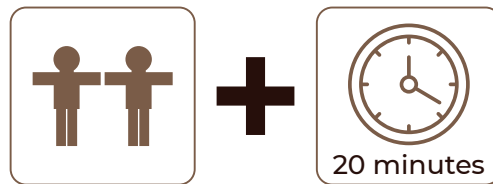
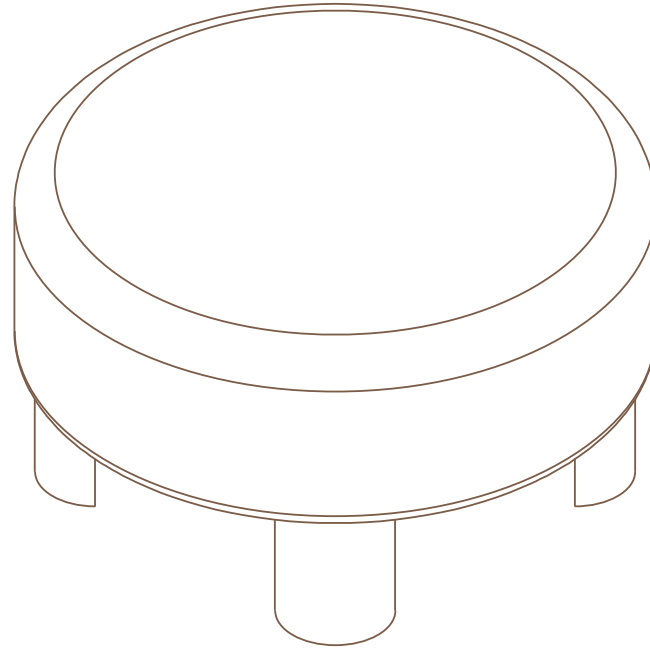

The use of power tools to assemble this product could lead to damage, making it unsafe

Please assemble on a clean, level surface to avoid damage and ensure proper assembly

Tools Required

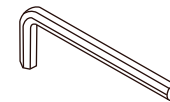

Allen Wrench
(included)

PARTS LIST

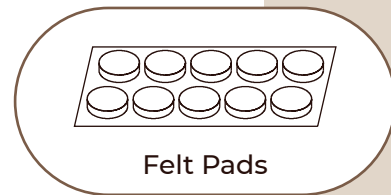
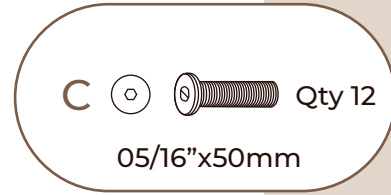
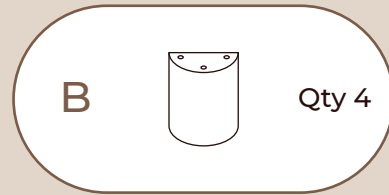
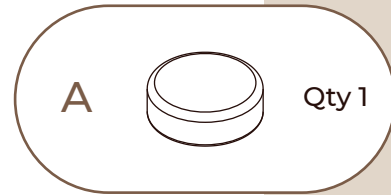
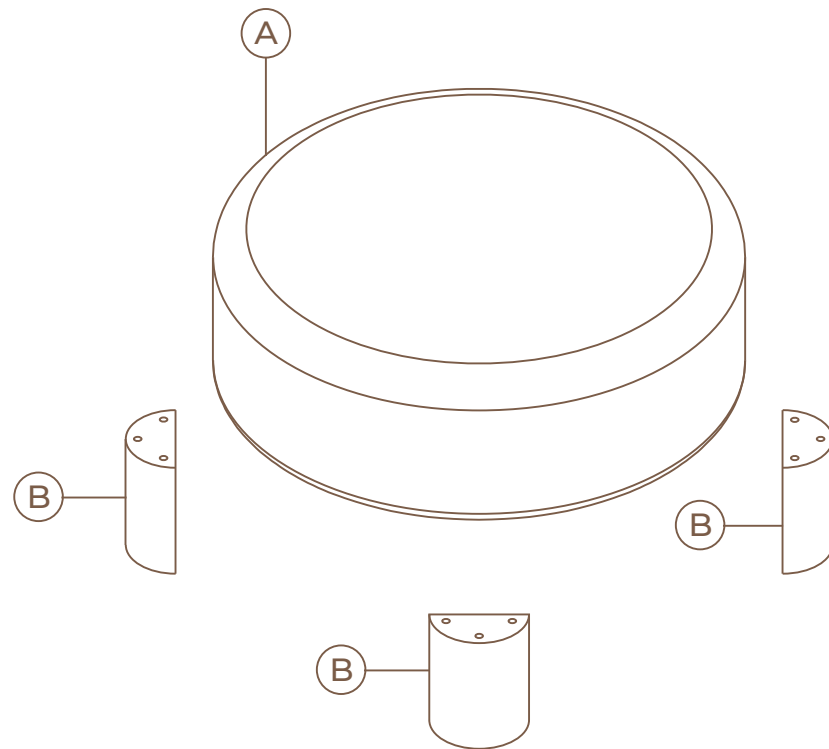

ASSEMBLY

STEP 1

Use the zipper to open the bottom, inside contains the leg box and hardware.

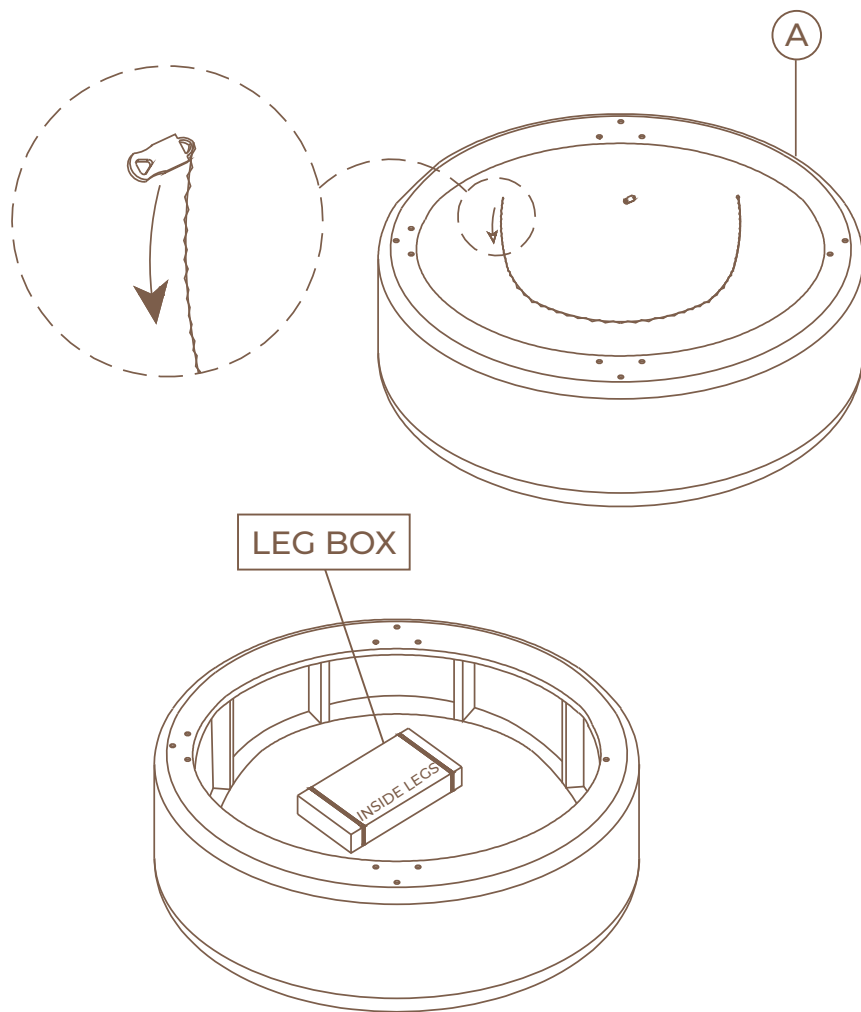

STEP 2

Attach 4 Legs (B) to Seat Frame (A) by using Allen Bolt (C), Lock Washer (D) and Flat Washer (E) and tighten with Allen Key (F).

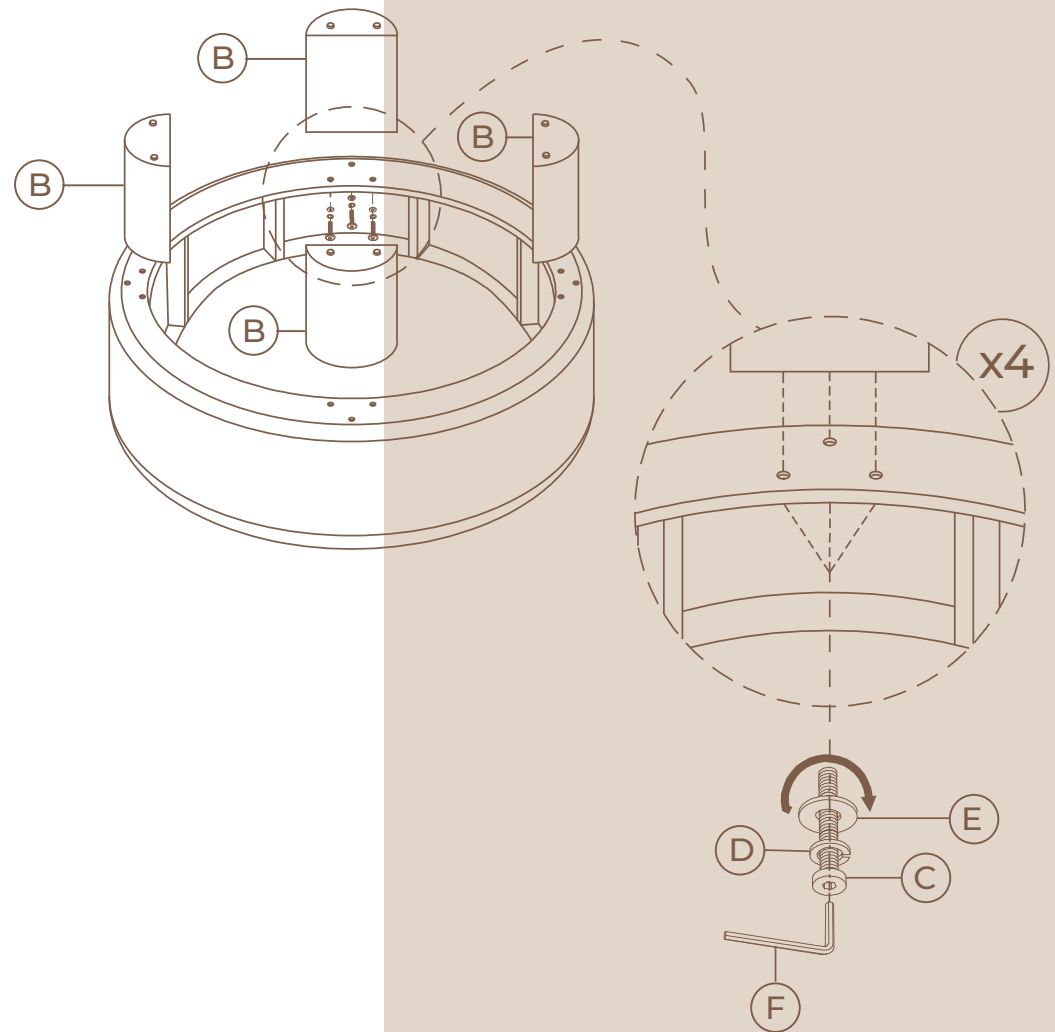

ASSEMBLY

STEP 3

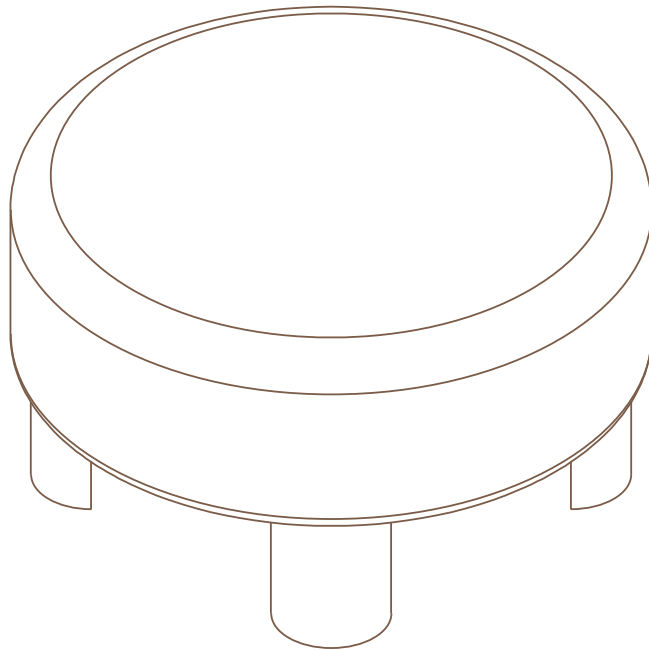

STEP 4: Felt Pad Application (optional)

1. Wipe any dust from the surface for best adhesion
2. Gently peel the felt pad from the paper
3. Firmly apply a felt pad to each of the feet

