

## BEFORE YOU BEGIN:

### Determine Your Fence Location:

- Make sure to call your local utility companies before you dig. (Dial 811 for assistance)
- For your safety, a proper utility locate is required before you begin to dig.
- Mark the location of the corner and gate posts to determine your fence line.



### Safety First:

**Always wear eye protection and cut resistant gloves when installing any fencing products.**

## TOOL CHECKLIST

- |  |   |
|--|---|
| <input type="checkbox"/> Hammer                    | <input type="checkbox"/> Eye Protection       |
| <input type="checkbox"/> Screwdriver / Power Drill | <input type="checkbox"/> Cut Resistant Gloves |
| <input type="checkbox"/> Bolt Cutters              |   |
| <input type="checkbox"/> Utility Knife             |   |
| <input type="checkbox"/> Adjustable Wrench         |   |
| <input type="checkbox"/> Pliers                    |   |
| <input type="checkbox"/> Scissors                  |   |

## INSTRUCTION SECTIONS:

- 1 TERMINATION BRACE (END POST) INSTALLATION
- 2 CORNER POST INSTALLATION
- 3 ATTACHING FENCE TO TERMINATION POST  
(Attach bottom fence line before unrolling fence material using the Spinning Jenny.)
- 4 UNROLLING THE BOTTOM FENCE STRAND  
(Bottom strand is laid out first as this will be a guide for the line posts.)
- 5 ATTACHING AND ADJUSTING FENCE WIRE TENSIONERS  
(A straight and tight bottom fence line will be your guide for line post installation.)
- 6 SPLICING STRANDS TOGETHER
- 7 INSTALL LINE POSTS AND ATTACH FENCE WIRE
- 8 MAKING ELECTRICAL CONNECTIONS

## 20 YEAR WARRANTY REGISTRATION

Products must be registered to receive coverage under this warranty. Please keep your wire fence product labels as the Product Label Number will be needed to complete this process.

(Note: Wire fence accessories are not covered by the 20 Year Warranty)

Warranty registration may be completed online at the following web address:

<http://www.centaurhttp.com/warranty.html>

If you are unable to register online, please call us for assistance:

**1-800-348-7787**

## Questions? We are here to help.

- Call us at **1-800-348-7787**
- Or visit our website [www.centaurhorsefence.com](http://www.centaurhorsefence.com) to locate a dealer / installer near you.



## 7 INSTALL LINE POST AND ATTACH FENCE:

Once bottom strand is tight and straight, use it as a guide for line post installation. Do not exceed 12 foot spacing between line posts. There are two line post options (Diagram 7):

- **Wood Post:** Use minimum of 4" diameter post. Wood Post Insulator is required for White Lightning (electric) and Barbed Staples may be used for PolyPlus (non-electric) attachment. *If using Barbed Staples, do not drive staple in tight. Fence wire must be able to move freely for proper tension adjustment.*
- **T-Post:** A T-Post Insulator Clip (attaches directly to T-Post), or Sure-Fit Safety Sleeve may be used to attach either White Lightning (electric) or PolyPlus (non-electric) fence. Safety Sleeve Clips are used to hold the strand in place (see Diagram 7)

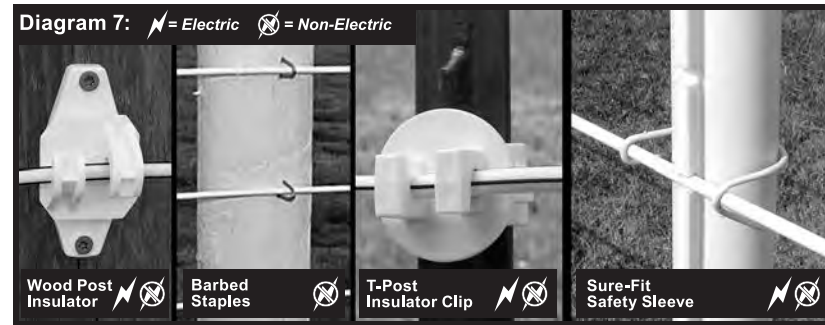

**Corner Post:** A Lag Corner Insulator holds wire away from the inside of corner posts. The built-in insulated roller mounts directly into the wooden post and may be used for either White Lightning (electric) or PolyPlus (non-electric) fence. **The Lag Corner Insulator is ideal for allowing proper fence tensioning through the inside of corner sections.**



Repeat Sections 3-7 to complete your installation. For even wire spacing, we recommend either making a template or marking your measurements directly onto the post.

## 8 MAKING ELECTRICAL CONNECTIONS:

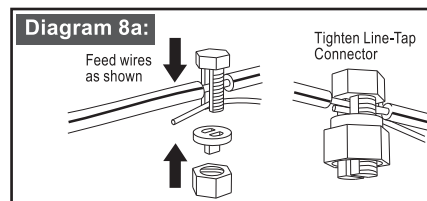

Use the Line-Tap Connector to connect White Lightning (electric) fence to ground wire (see Diagram 8a) for electrification. Undergate cable should be used as an insulated wire to make connections. The Line-Tap Connector can also be used to connect wires when cross-fencing.

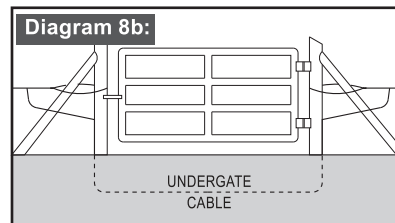

Bury the Undergate Cable a minimum of 8 to 12 inches underneath gates to carry power (see Diagram 8b). If gate is in a high traffic area, consider using a suitable conduit for optimum protection. Follow the fence energizer manufacturer's installation instructions.

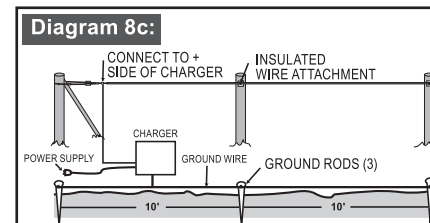

Ground rods must be driven 8 feet into the soil to provide sufficient ground (see Diagram 8c).

*All energizers should work with White Lightning, but an intermittent, AC, low-impedance energizer is preferred. Though we show general methods used for grounding the charger, wiring across gates and lightning protection; we defer to the charger supplier's suggestions if different from those offered here.*

# White Lightning® Electric and PolyPlus HTP® Non-Electric Single Strand Coated Wire Fence INSTALLATION GUIDE

## ACCESSORIES CHECKLIST

### White Lightning®

#### (Electric Coated Wire Fence):

- Spinning Jenny
- Ratchet Style Tensioner Handle
- Diagonal Brace Plate
- Wire Links (12.5 gauge wire link / can be used for electric and non-electric coated wire fence)
- Quick End (wire connector / can be used for electric and non-electric coated wire fence)
- Insultube (tubing used to insulate electric wire fence when installed with Quick End)
- Fencer's Lasso® (used to tension wire fence / insulated with built-in loop / can be used for electric and non-electric coated wire fence)
- Barbed Staples (minimum 1-3/4 inch - for attaching Fencer's Lasso®)
- Lag Corner Insulator (holds wire away from the inside of corner posts / can be used for electric and non-electric coated wire fence)
- Line-Tap Connector (makes electrical wire connections)
- Undergate Cable (carries power from energizer to fence / can be buried)

#### For Wood Post Installation Use:

- Wood Post Insulator

#### For T-Post Installation Use:

- T-Post Insulator (clips directly to metal T-Post / can be used for electric and non-electric coated wire fence)
- Sure-Fit® Safety Sleeve (insulated cover for T-Post / can be used for electric and non-electric coated wire fence)
- Safety Sleeve Clip (used to attach wire to Sure-Fit® Safety Sleeve)



### PolyPlus HTP®

#### (Non-Electric Coated Wire Fence):

- Spinning Jenny
- Ratchet Style Tensioner Handle
- Diagonal Brace Plate
- Wire Links (12.5 gauge wire link / can be used for electric and non-electric coated wire fence)
- Quick End (wire connector / can be used for electric and non-electric coated wire fence)
- Fencer's Lasso® (used to tension wire fence / insulated with built-in loop / can be used for electric and non-electric coated wire fence)
- In-Line Tensioner (used to tension wire fence / mounts directly to wood post / can only be used for non-electric coated wire fence)
- Lag Corner Insulator (holds wire away from the inside of corner posts / can be used for electric and non-electric coated wire fence)

#### For Wood Post Installation Use:

- Barbed Staples (large 1-3/4" galvanized staples that allow room for tensioning wire fence)

#### For T-Post Installation Use:

- T-Post Insulator (clips directly to metal T-Post / can be used for electric and non-electric coated wire fence)
- Sure-Fit® Safety Sleeve (insulated cover for T-Post / can be used for electric and non-electric coated wire fence)
- Safety Sleeve Clip (used to attach wire to Sure-Fit® Safety Sleeve)



## ① TERMINATION BRACE (END POST) INSTALLATION:

After determining fence location, terminations (end / brace posts) must be installed. Terminations serve as anchor points for the fencing. We recommend two types of terminations.

- Diagonal Brace
- Horizontal / Diagonal Brace

### 1a. DIAGONAL BRACE INSTALLATION

An 8 foot long post with a minimum 6 inch diameter can be used for the upright post. The post should be installed a minimum of 3 feet deep and set in concrete. Try to leave concrete 6 inches below ground level. Diagram 1a shows a proper diagonal brace installation.

Diagram 1a:

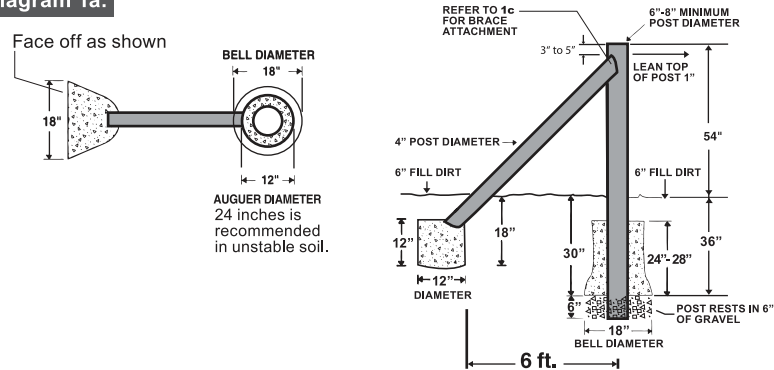

### 1b. HORIZONTAL / DIAGONAL BRACE INSTALLATION

For a stronger end or gate post, use a horizontal / diagonal brace. Diagram 1b shows a proper horizontal / diagonal brace installation.

Diagram 1b:

#### Notes:

1. The depth of concrete may vary depending on frost lines in your area. Consult local codes for details.
2. Lean post 1 inch away from the directional pull.
3. A 24 inch bell diameter is recommended in unstable soil.
4. It is recommended to auger a 16 inch diameter hole, 3 feet deep with a bell and a 4 foot, 16 inch diameter in Canada.

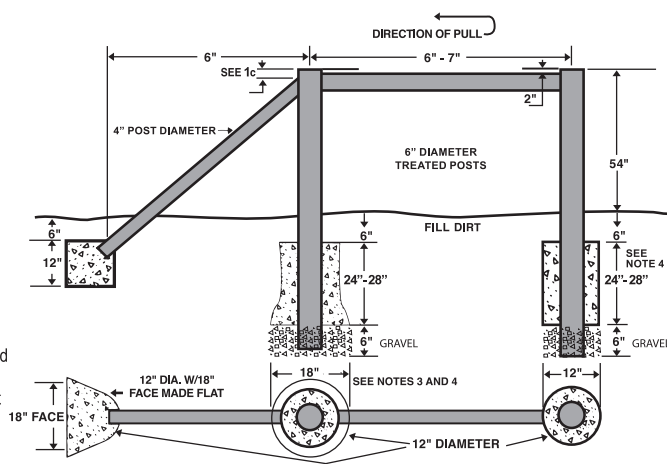

### 1c. ATTACHING DIAGONAL BRACE

Use a diagonal brace plate shown in diagram 1c (below) to securely attach diagonal braces. (either 3-1/2 inch ring shank nails or 2-1/2 inch screws recommended).

Diagram 1c:

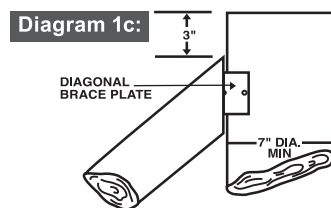

## ② CORNER POST INSTALLATION:

When planning a 90° corner, reinforce upright as shown in the diagram below. (The diagram is a top view of the post layout.)

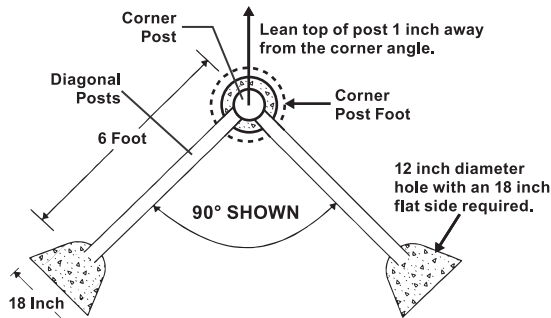

**2a :** This diagram points out the corner post and the single strand wire running on the outside of the line posts.

**2b:** This diagram shows the single strand wire running on the inside of the posts. **Note:** When running wire on the inside of posts, a Lag Corner Insulator is ideal for proper attachment (see Section 7).

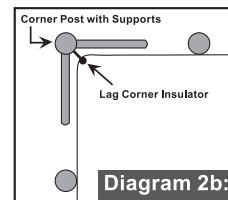
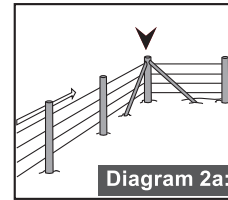

## ③ ATTACHING FENCE TO TERMINATION POST:

**Note:** If planning on painting your fence posts, it is recommended that you paint your posts first before attaching your fence accessories.

The bottom strand is installed first because it will be used as a guide for the line post installation. There are two methods of attachment. Diagram 3a is for White Lightning (electric) and Diagram 3b is for PolyPlus (non-electric) coated wire.

**If using a vehicle to hold the Spinning Jenny while unrolling your fence wire, it is important to attach the bottom fence line to a termination post first before paying out your material (see Section 4).**

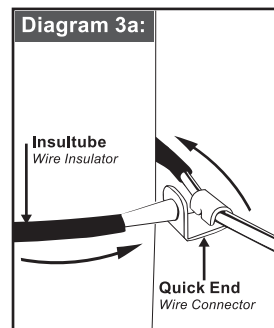

### White Lightning (electric) Diagram 3a:

Because of electric current, insulation (Insultube) must be used when attaching the White Lightning fence wire to the termination post. To avoid grounding, only Insultube may be allowed to touch the post.

1. Place a section of Insultube on along the end portion of the White Lightning fence wire to protect against grounding.
2. Use the Quick End connector to secure fence wire around the post. Simply strip 1 inch of coating from the wire, feed the wire through the Quick End, wrap around post, and insert bare end of wire into the spring-loaded end to lock into place.

**Note:** The Quick End may also be used with PolyPlus (non-electric wire) for fast and easy installation. Insultube is only required for White Lightning (electric wire) fence connections.

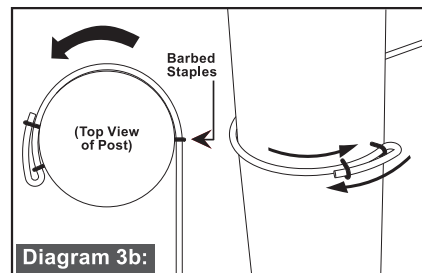

### PolyPlus (non-electric) Diagram 3b:

Because this is a non-electric fence wire, barbed staples may be used to secure to the post.

1. Wrap the PolyPlus around the post as shown and drive staples in half way.
2. Thread the PolyPlus back through the staples as shown, cut off excess wire and hammer staples in tight to secure.

## ④ UNROLLING THE BOTTOM FENCE STRAND:

It is important to install the bottom fence line first as this will be your guide for the line post installation. Place the fence roll securely on the Spinning Jenny. If you plan on using a vehicle to unroll the fence wire, you must attach the bottom fence line to a termination post first before paying out your material (see Section 3). The Spinning Jenny helps to prevent wire kinks and tangles during installation.

Diagram 4:

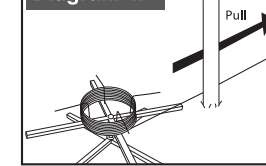

### Walking Fence Material:

If you do not wish to use a vehicle, you may place the Spinning Jenny on the ground and hold the wire as you walk the material out along your fence line (Diagram 4). Then follow instructions from Section 3 to attach the end of the fence wire to the termination post.

## ⑤ ATTACHING & ADJUSTING FENCE TENSIONERS:

There are two types of tensioners available. One is the insulated Fencer's Lasso (Diagram 5a) compatible with White Lightning (electric) and PolyPlus (non-electric) wire fence. The second option is the In-Line Tensioner (Diagram 5e) that may only be used with PolyPlus (non-electric) wire fence as it does not contain insulation.

Diagram 5a:

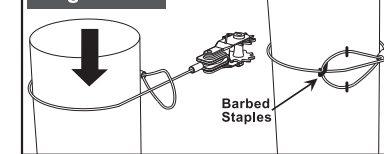

### Fencer's Lasso:

(for electric & non-electric wire)

1. Thread the tensioner through the pre-formed loop and slide over the post. Then, set to desired height & secure with barbed staples. Hammer until tight and flush with the post (see Diagram 5a).

2. Using a utility knife, strip approx. 1.5 inches of coating to expose the bare metal wire. (Be sure to wear cut resistant gloves for safety).

3. Thread the stripped wire through the hole in the tensioner spool and use pliers to bend the wire in place (see Diagram 5b).

4. Using the Ratchet Style Tensioner Handle, wind the wire at least one complete turn around the spool (see Diagram 5c). Wire should be tight and straight. As you adjust tension, be sure that the tensioner lever (see Diagram 5d) is locking into place. This lever keeps the spool from unwinding.

Diagram 5b:



Diagram 5c:

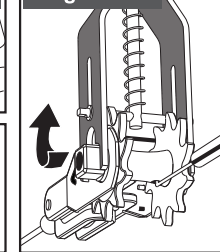
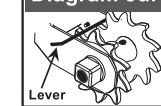

Diagram 5d:



**Note:** Be careful not to wind too much material onto the spool. Excess material may cause improper function of the tensioner.

**\*\*If you do not have a Ratchet Style Tensioner Handle, an adjustable wrench may be used\*\***

Diagram 5e:

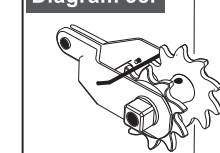

### In-Line Tensioner:

(for non-electric wire only)

1. The In-line Tensioner is mounted directly to the wood post (see Diagram 5e). A 5 inch nail is recommended.
2. Follow steps 2, 3 & 4 in the Fencer's Lasso Instruction above to insert and tension the PolyPlus non-electric wire.

## ⑥ SPLICING STRANDS TOGETHER:

Wire Links securely splice wire together for a smooth safe connection. Quick and easy with no special tools needed. Simply strip off approximately 1.5 inches of wire coating and insert the bare wire into each end of the wire link (Diagram 6), **Wire Links may be used for both White Lightning (electric) and PolyPlus (non-electric) wire fence.**

Diagram 6:



**Note:** Once wire is inserted, it is permanently locked within the wire link.