

ASSEMBLY INSTRUCTIONS

ARC TABLE

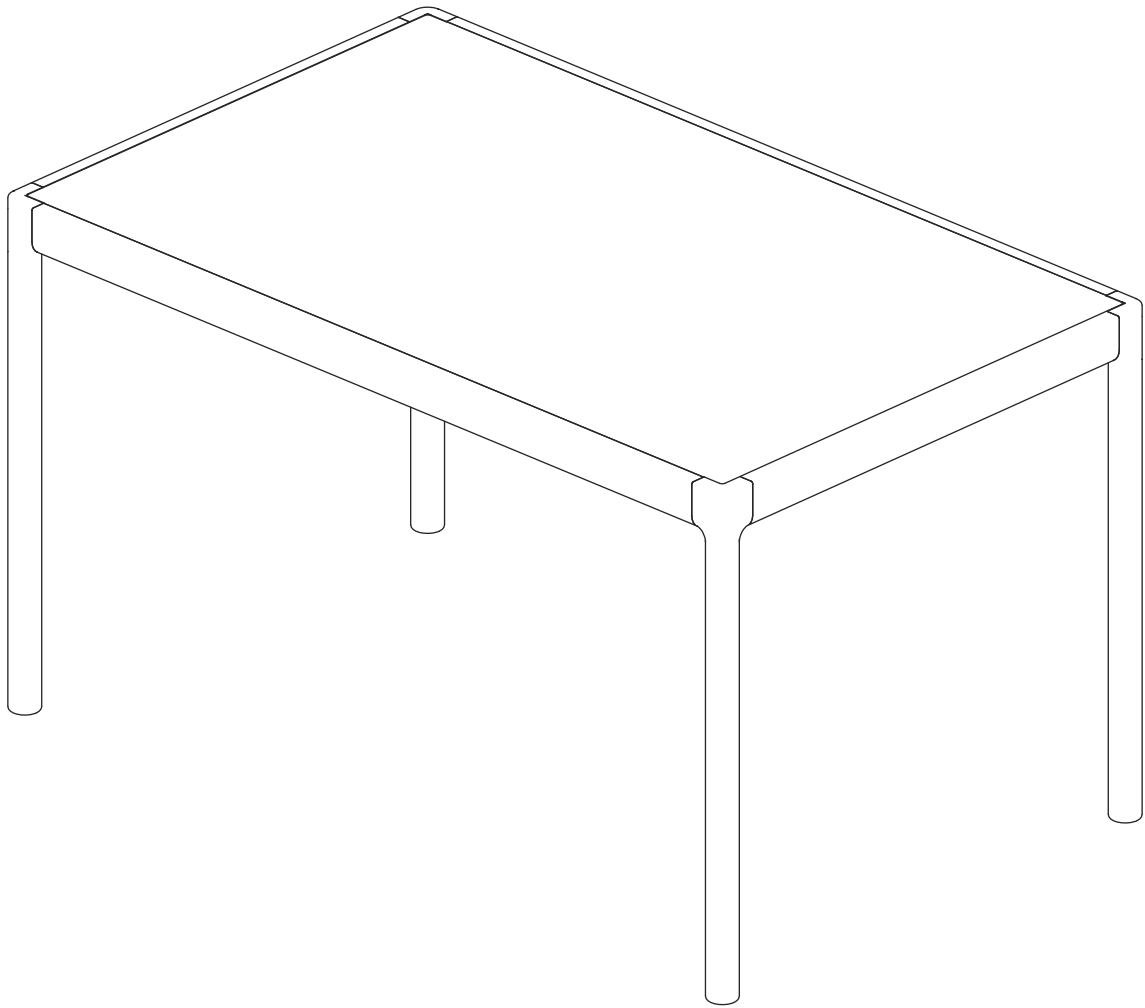

Arc Table

Assembly Instructions

Product Information

‘Arc Table’ is a table designed for indoor use.

Materials

Table top: Natural veneer on Birch plywood

Stretchers: Solid wood

Leg component: Solid wood

Surface treatment: Hardwax oil

Fittings: Steel

Important Notice

Only use the listed tools.
Do not use power tools.
Tighten in accordance with
the building instructions.
Avoid over-tightening.
There is no need for strong
force.

2x leg components (solid wood)

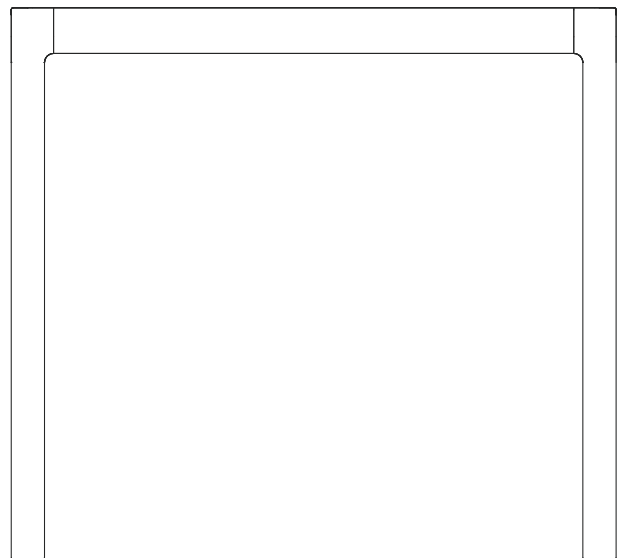
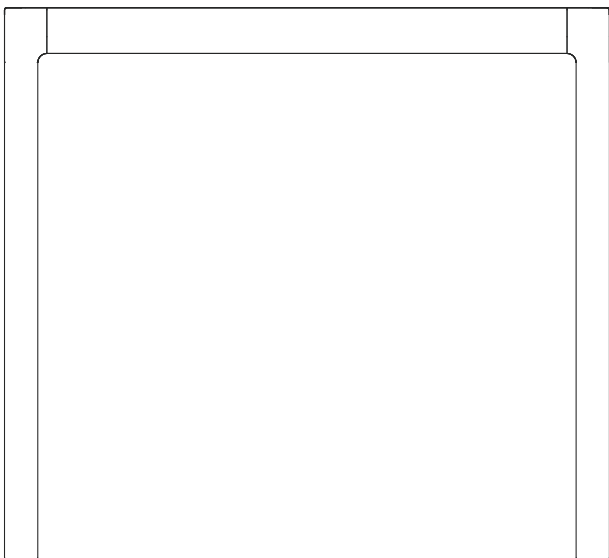

1x table top (solid wood and natural veneer on Birch plywood)

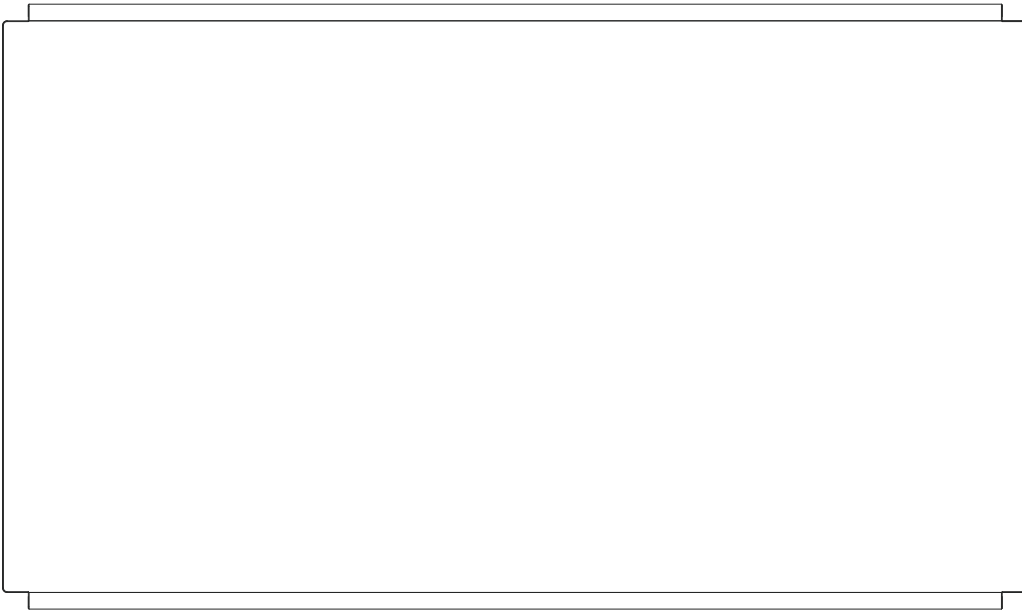

4x grub screws



1x Allen key



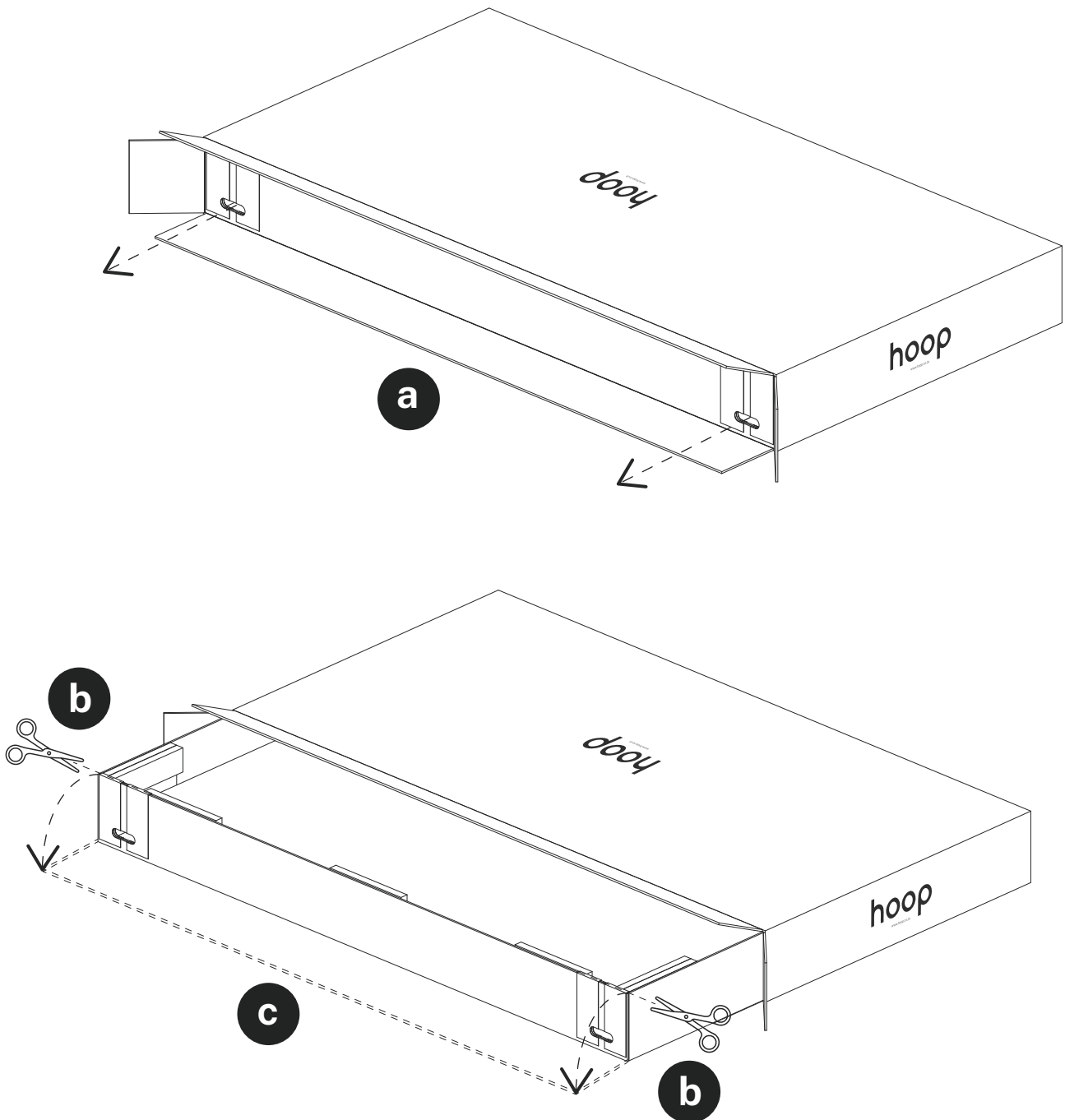

Box opening

- a) Making sure that the 'hoop' logo is facing upwards, as shown, safely use a cutter to open the side of the cardboard box.
- b) Pull the inner tray using the handles provided.
- c) To remove the table top: cut the paper tape at the ridge on each end of of the cardboard tray, as shown.

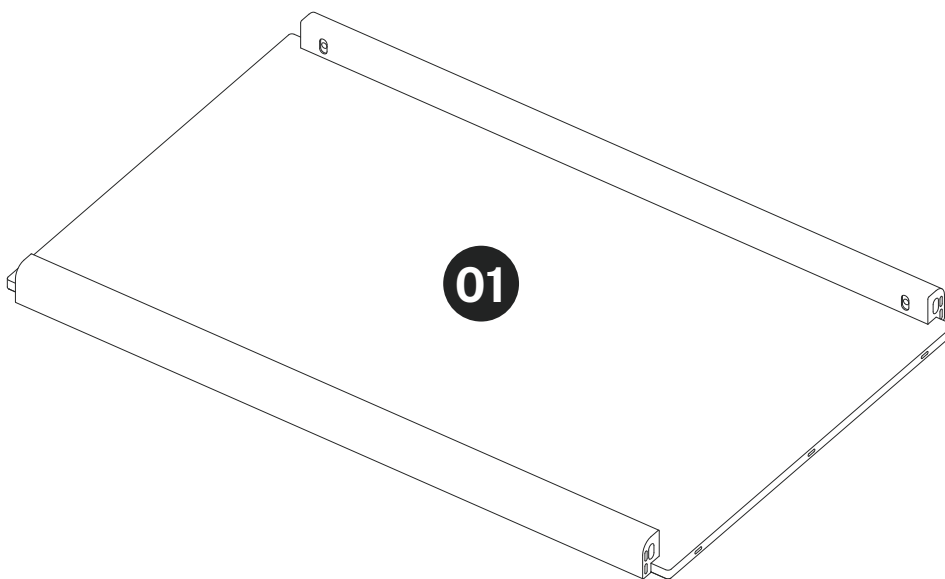

Step 01

Place the table top on a soft underlay, with the bottom facing upwards.

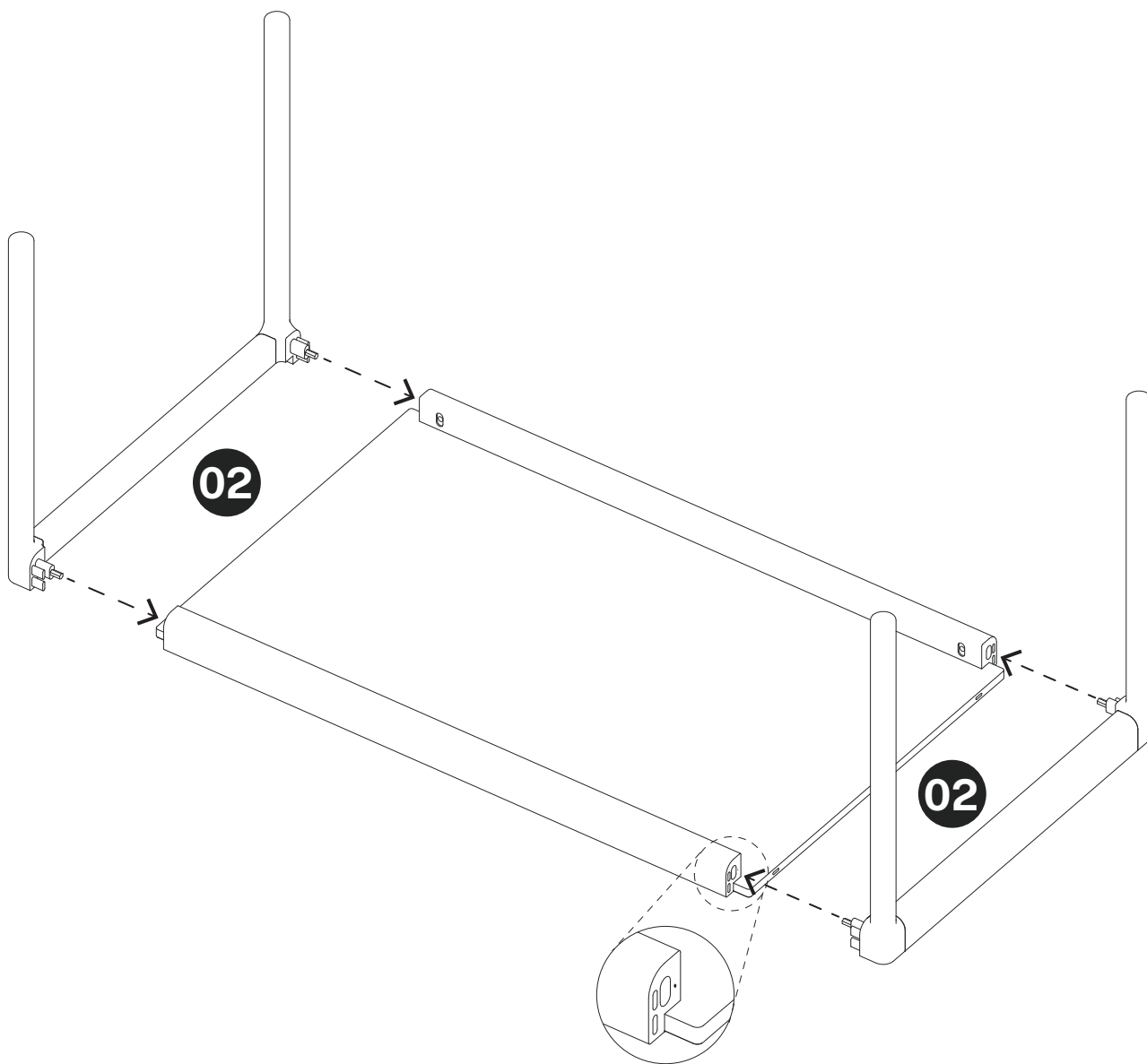

Step 02

Making sure to match the corresponding leg to each side of the top by means of mark ‘•’ or mark ‘••’, gently insert the leg component by aligning the dowels with the provisions made in the table top component.

Be careful to apply equal pressure to both side of the leg component when coupling the table top.

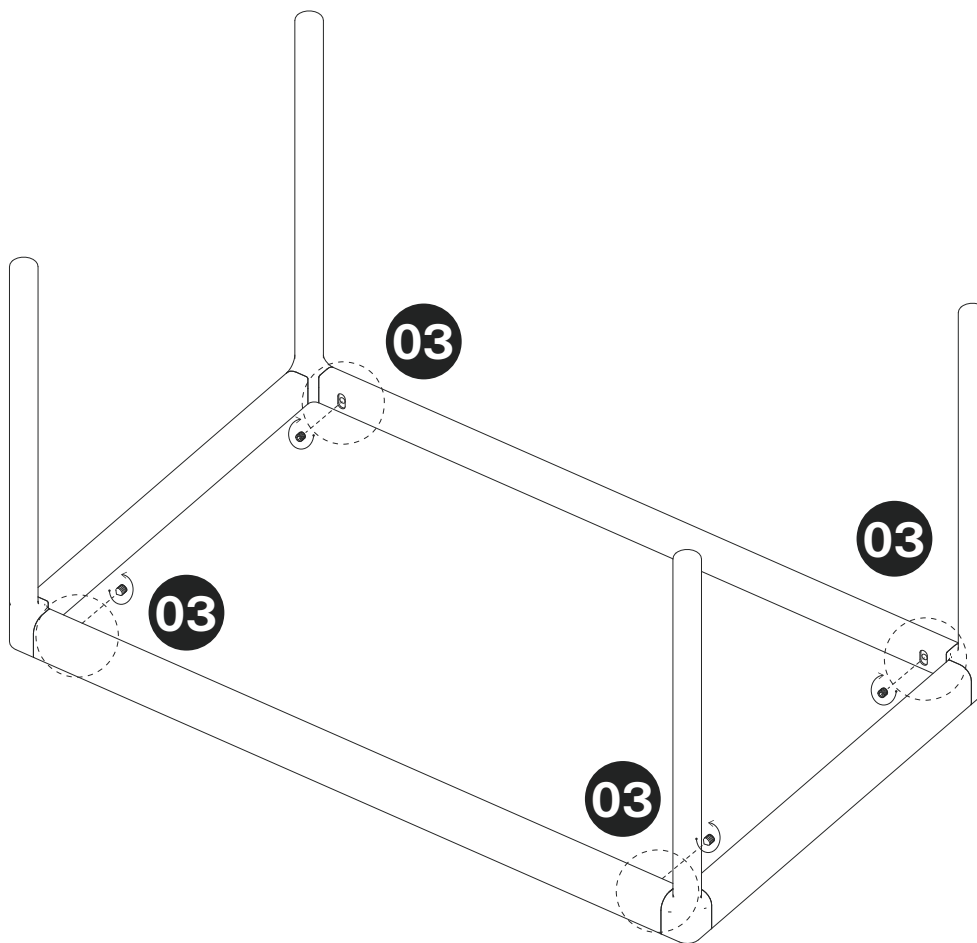

Step 03

Lightly fasten legs to top by inserting and turning all grub screws six rounds at each corner.

Once all parts have been mounted, tighten all screws.

Notice: Do not over-tighten.

