Table of Contents

SECTION 1 1

Electrical / CE interlocks 1

 Wrg_1002P_sht_1of6_vmc_electrical 2

 Wrg_1002M_sht_2of6_vmc_electrical 3

 Wrg_1002J_sht_3of6_vmc_electrical 4

 Wrg_1002J_sht_4of6_vmc_electrical 5

 Wrg_1002K_sht_5of6_vmc_electrical 6

 Wrg_1002C_sht_6of6_vmc_electrical 7

 WRG_1002T_sht_1of6_vmc_electrical 8

 WRG_1002T_sht_2of6_vmc_electrical_Note and Option 9

 WRG_1002T_sht_4of6_vmc_electrical_Spindle Drive Connections 10

 WRG_1002T_sht_5of6_vmc_electrical_Pallet Changer 11

 WRG_1002T_sht_6of6_vmc_electrical_Dual Arm and Auger 12

 WRG_0030C_vmc_ac_brushless_power 13

 Wrg_0058B_vmc_ac_brushless_control 14

 Wrg_0059B_vmc_ac_brushless_pendant 15

 Wrg_0064B_vmc_ac_brushless_connectors 16

 Wrg_0065B_vmc_ac_brushless_options 17

 Wrg_0696C_ce_door_interlock_wiring_diagram_ac_brushless_sheet_1of3 18

 Wrg_0696C_ce_door_interlock_wiring_diagram_dc_machine_sheet_2of3 19

 Wrg_0696B_ce_door_interlock_wiring_diagram_4th_5th_axis_sheet_3of3 20

 Wrg_0041F_ce_door_lock_2030-0A_wiring_diagram_1of3 21

 Wrg_0041F_ce_door_lock_2030-0A_wiring_diagram_2of3 22

 WRG_0040C_coolant_pump 23

SECTION 2 25

Spindle 25

 WRG_0023E_wye_delta_contactors 26

 Wrg_0024A_spindle_motor_connection 27

 Wrg_0026B_1980_0_15k_air_oil 28

 WRG_0043A_encoder_cable_E5D 29

 WRG_0046C_Tool_IO_switch_on_spindle 30

SECTION 3 31

4th & 5th Axis/Servo Options	31
Wrg_0033A_dc_abaxis_for_ac	32
Wrg_0034A_dc_4axis_for_ac	33
Wrg_0014C_ac_4th_axis_for_ac_brushless_std_slant98	34
Wrg_0015_4th_5th_with_mechanical_limit_switch	35
Wrg_0016B_ac_4th_5th_axis_for_ac_brushless_std_slant98	36
Wir_0533_servo_coolant	37
Wrg_0179A_servo_turret_wiring_diagram	38
WRG_0179A_sht2of2_servo_turret_harness	39
WRG_0671A_4th_axis_harness_for_ac_brushless	40
SECTION 4	41
Probes / Scales	41
Wrg_0003_ts27_probe	42
Wrg_0004_mp11_probe	43
Wrg_0005_mp12_24v_power_supply	44
Wrg_0006_mp11_ts27_with1570_1_board	45
Wrg_0007B_mp12_ts27_with1570_1_board	46
Wrg_0008_mp12_omi_1	47
Wrg_0009_mp12_omi_ts27_1570_1	48
Wrg_0027A_scale	49
SECTION 5	51
Options	51
WRG_0011C_sht1of2_hydro_sweep_3valves	52
WRG_0011A_sht2of2_hydro_sweep_harness	53
Wrg_0012C_hydro_sweep_6valves	54
Wrg_0013B_hydro_sweep_coolant_thru	55
Wrg_0022A_hydro_sweep_1990_1a_board	56
Wrg_0017B_pallet_changer	57
Wrg_0018B_pallet_changer_hydro_sweep	58
Wrg_0037F_auger_washdown_coolantthru	59
Wrg_0693J_auger_washdown_wiring_diagram	60
WRG_0001K_Dual_Arm_Tool_Changer_1330-1	61
WRG_0044D_6535_washdown	62
WRG_0045B_CE_wiring_Hennig_Chip_Conveyor	63
WRG_0047F_Remote_TurCW_TurCCW_for_50_Taper	64
Wrg_0050A_air_oil_system_50tap	65
Wrg_0051A_15_pin_connector_50tap	66
SECTION 6	67
Pendant	67

WRG_0020D_pendant_wiring_1990_1_board	68
WRG_0021B_1990_2_board_32mp	69
WRG_0025B_pendant_wiring_1990_1_board_color_vga	70
Wrg_0028B_MPG	71
Wrg_0029A_disk_drive_1of2	72
Wrg_0029B_disk_drive_2of2	73
Wrg_0010C_ethernet	74
Wrg_0052A_rmpg_euchner	75
WRG_0057B_pendant_wiring_LCD_monitor	76
SECTION 7	77
Transformers	77
Lbl_0026C_label_t818_transformer_340-510V	78
Lbl_0027D_label_t820_transformer_190-510V	79
Lbl_0278D_label_t818ce_transformer_340-510V	80
LBL_0279D_label_t812_transformer_240V	81
LBL_0280D_label_t812_transformer_single_phs_ac_240V	82
LBL_0285D_label_t812_transformer_single_phs_dc_240V	83
WRG_0042A_TransformerThermalSwitch	84
Wrg_0054A_6535_50tap_siemens810_Std	85
Wrg_0066A_6535_50tap_siemens810_rot_scale	86
Wrg_0067_6535_40tap_siemens810_std	87
Wrg_0068A_atc_wiring	88
SECTION 8	89
Siemens	89
WRG_0002H_siemens_control_1of5	90
WRG_0002H_siemens_control_2of5	91
WRG_0002H_siemens_control_3of5	92
WRG_0002H_siemens_control_4of5_electrical	93
WRG_0001K_Dual_Arm_Tool_Changer_1330-1	94
Wir_0019C_scale_cable_siemens	95
Wrg_0031A_mp12_probe_siemens	96
Wrg_0035D_ts27_probe_siemens	97
Wrg_0036D_mp12_ts27_combo_siemens	98
Wrg_0038A_mp11_siemens	99
Wrg_0002I_siemens_control_5of5	100
WRG_0060A_Dual_Arm_Tool_Changer_Siemens	101
WRG_0039B_siemens_840D_1of2	102
WRG_0039B_siemens_840D_2of2	103

SECTION 9	105
EMC	105
WRG_0048C_emc_1of4	106
WRG_0048C_emc_2of4	107
WRG_0048C_emc_sp_drive_315_3of4	108
WRG_0048C_emc_sp_drive_515_4of4	109
Wrg_0053A_emc_disk_drive_harness	110
WRG_0041F_ce_door_lock_2030-0A_wiring_diagram_1of3	111
WRG_0041F_ce_door_lock_2030-0A_wiring_diagram_2of3	112
WRG_0041F_ce_door_lock_EMC_2030-0A_wiring_diagram_3of3	113
WRG_0049B_emc_4th_axis	114
SECTION 10	115
Chip Conveyor	115
WRG_0045B_CE_wiring_Hennig_Chip_Conveyor	116
WRG_0062A_US_wiring_Hennig_Chip_Conveyor	117
WRG_0063A_CE_wiring_Siemens_Hennig_Chip_Conveyor	118
WRG_0083A_sht1of2_104D_US_wiring_Hennig_Chip_Conveyor	119
WRG_0083A_sht2of2_CE_wiring_Hennig_Chip_Conveyor 104D	120
SECTION 11	121
Washdown	121
WRG_0037F_auger_washdown_coolantthru	122
WRG_0044D_6535_washdown	123
Wrg_0081X_15of22_hmc_wash_conv_cool	124
WRG_0082X_104D_wash	125
WRG_0693J_auger_washdown_wiring_diagram	126
SECTION 12	129
104D	129
Wrg_0069A_01of12_104d_21101_std	130
Wrg_0069A_02of12_104d_21102_std	131
Wrg_0069A_03of12_104d_21060_std	132
Wrg_0069A_04of12_104d_pumps_std	133
Wrg_0069A_05of12_104d_amp_std	134
Wrg_0069A_06of12_104d_dc_power_supply_std	135
Wrg_0069A_07of12_104d_nmsbx1_std	136
Wrg_0069A_08of12_104d_nmebx2_std	137
Wrg_0069A_09of12_104d_box_panel_std	138
Wrg_0069A_10of12_104d_raptor_std	139
Wrg_0069A_11of12_104d_24vdc_power_supply_std	140

Wrg_0069A_12of12_104d_21290_brake_board	141
Wrg_0070A_1of5_104d_can_ethernet_usb_cable	142
Wrg_0070A_2of5_104d_in_out_nmebx	143
Wrg_0070A_3of5_104d_keyboard_mause_cable	144
Wrg_0070A_4of5_104d_power_harness_internal	145
Wrg_0070A_5of5_104d_vga_serial_parallel_cable	146
WRG_0074X_1of4_104d_control_cable	147
WRG_0074X_2of4_104d_21060 to 21101 21101 to 21102 cable	148
WRG_0074X_3of4_104d can vga usb cable	149
WRG_0074X_4of4_104d motor signal power cable	150
WRG_0075X_1of6_104D_trans240	151
WRG_0075X_2of6_104D_trans480	152
WRG_0075X_3of6_104D_transVHT	153
WRG_0075X_4of6_104D_transCE	154
WRG_0075X_5of6_104D_transVHTCE	155
WRG_0075X_6of6_104D_trans_single_ph	156
WRG_0077X_01of02_104D_21330	157
WRG_0077X_02of02_104D_datc	158
WRG_0078X_104D_atc	159
WRG_0079X_104D_spindle_drive	160
WRG_0080X_104D_lube_pump	161
WRG_0082X_104D_wash	162
WRG_0083A_sht1of2_104D_US wiring_Hennig_Chip_Conveyor	163
WRG_0083A_sht2of2_CE_wiring_Hennig_Chip_Conveyor 104D	164
Wrg_0084_104d_pendant_21091	165
WRG_0087A_CE_Interlock_Wiring_Diagram_104D	166
SECTION 13	167
TRM	167
Wrg_0055A_trm_power_in_1of8	168
Wrg_0055A_trm_DC_psupply_n2_2of8	169
Wrg_0055A_trm_1105_3of8	170
Wrg_0055A_trm_amp_4of8	171
Wrg_0055A_trm_1060_5of8	172
Wrg_0055A_trm_1060connectors_6of8	173
Wrg_0055A_trm_pendant_7of8	174
Wrg_0055A_trm_ref_8of8	175
WRG_0071A_trm_a_axis	176

SECTION 1

Electrical / CE interlocks

Wrg_1002P_sht_1of6_vmc_electrical

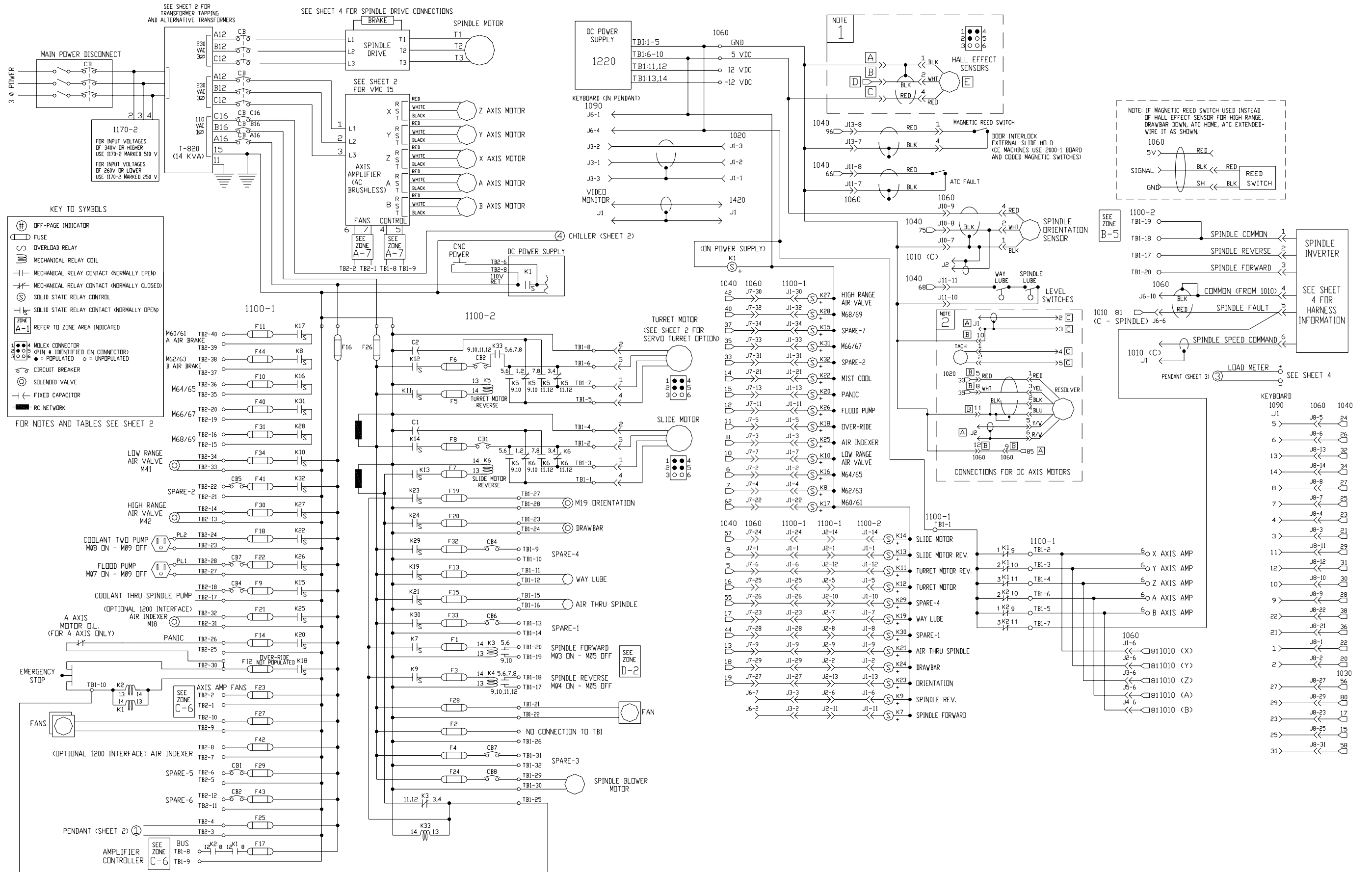

Wrg_1002M_sht_2of6_vmc_electrical

CE TRANSFORMERS & CIRCUIT BREAKERS

TRANSFORMER DIAGRAMS:

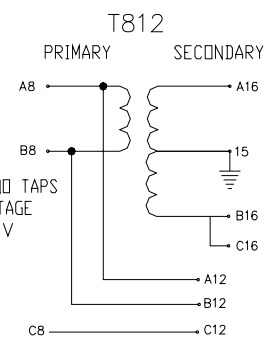
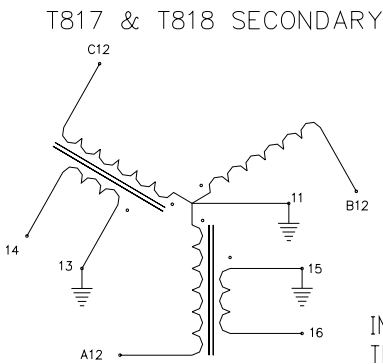
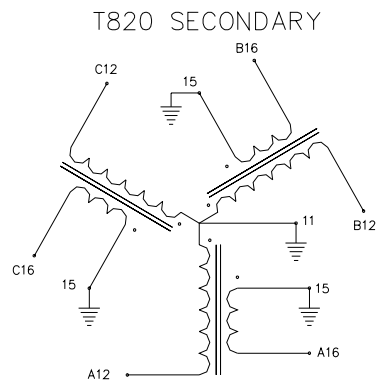

T812 HAS NO TAPS
INPUT VOLTAGE
220 - 240 V
60 HZ

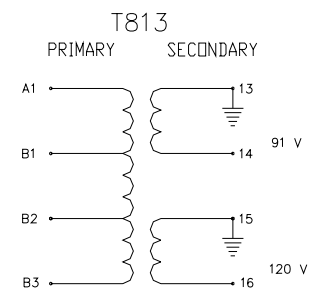

INPUT CONNECTIONS FOR MULTITAP TRANSFORMERS (EACH PHASE A, B & C)

INPUT VOLTAGE	JUMPER 3 PLS	AC INPUT
190	NONE	2
200	2-7	8
210	2-5	6
230	2-6	7
240	2-6	8
250	2-5	7
260	2-5	8
340	NONE	3
350	3-7	8
360	3-5	6
380	3-6	7
390	3-6	8
400	3-5	7
410	3-5	8
440	NONE	4
450	4-7	8
460	4-5	6
480	4-6	7
490	4-6	8
500	4-5	7
510	4-5	8

TRANSFORMER OUTPUTS

TRANSFORMER	TERMINAL	VOLTAGE
T817, T818, T820	11	GROUND FOR 240 V 3-PHASE
T817, T818, T820	A12, B12, C12	240 V 3-PHASE
T812, T820	A16, B16, C16	120 V SINGLE PHASE
T813, T817, T818	16	120 V SINGLE PHASE
ALL	15	RETURN FOR 16 (GROUNDED)
T813, T817, T818	14	120 V FOR DC AXIS AMPLIFIER CHASIS
T813, T817, T818	13	RETURN FOR 14, (GROUNDED)

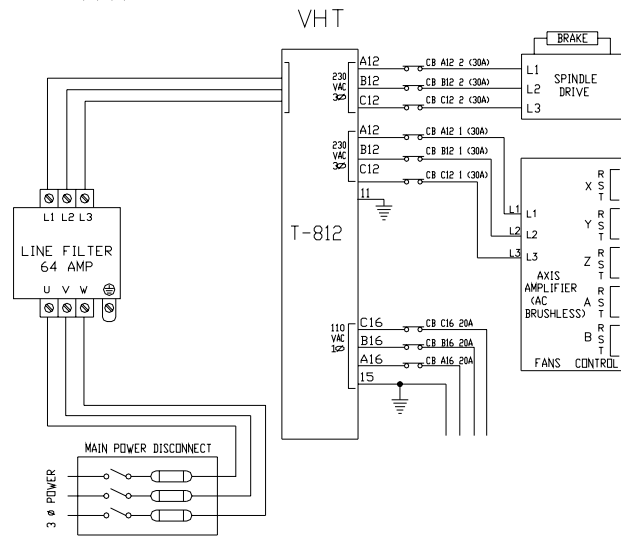
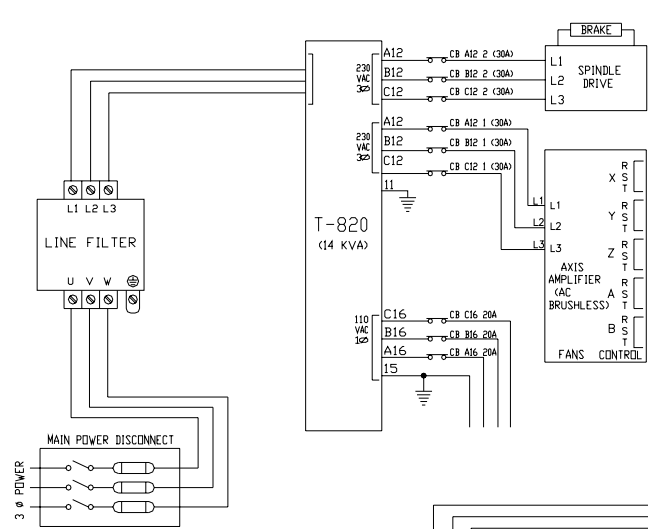

CHILLER

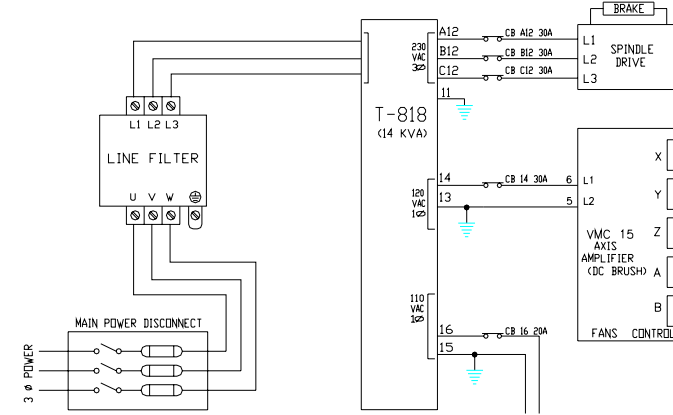
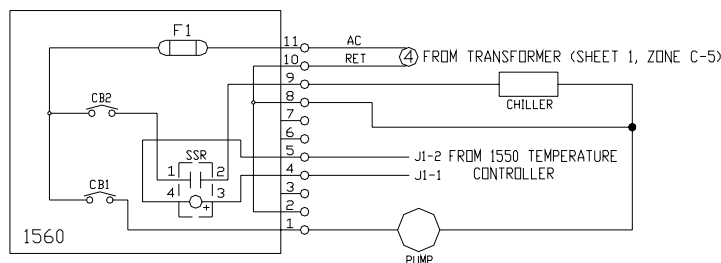

VMC 15 AXIS AMPLIFIERS

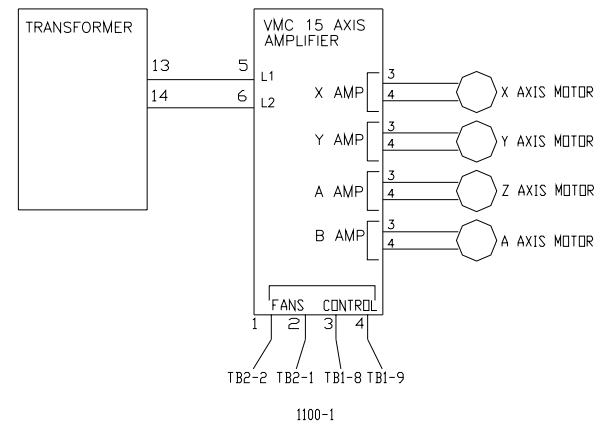

SERVO TURRET OPTION

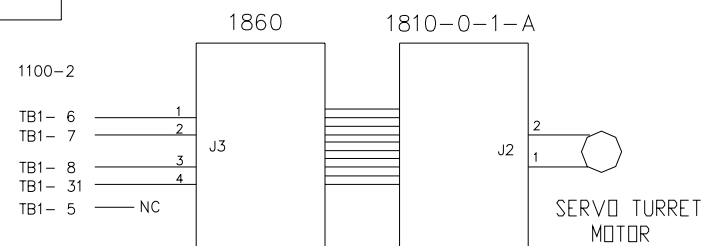

NOTES

1 SENSOR TABLE

SENSOR	1040	1060		
		A	B	C
SLIDE EXTENDED	70	J12-1	J12-2	J12-3
SLIDE HOME	72	J12-4	J12-5	J12-6
TURRET MOTION	74	J12-7	J12-8	J12-9
DRAWBAR DOWN	50	J9-1	J9-2	J9-3
HIGH RANGE	54	J9-10	J9-11	J9-12
LOW RANGE	58	J11-4	J11-5	J11-6

2 TYPICAL OF EACH AXIS (FOR D.C. MOTORS ONLY)

	A	B	C
X AXIS	1010 (X)	1060 J1	X AXIS AMP
Y AXIS	1010 (Y)	1060 J2	Y AXIS AMP
Z AXIS	1010 (Z)	1060 J3	Z AXIS AMP
A AXIS	1010 (A)	1060 J5	A AXIS AMP
B AXIS	1010 (B)	1060 J4	B AXIS AMP

BOARD DESCRIPTION

BOARD #	LOCATION	FUNCTION
1010 (X)	SLOT 9	X AXIS CONTROLLER
1010 (Y)	SLOT 10	Y AXIS CONTROLLER
1010 (Z)	SLOT 11	Z AXIS CONTROLLER
1010 (A)	SLOT 13	A AXIS CONTROLLER
1010 (B)	SLOT 12	B AXIS CONTROLLER
1010 (C)	SLOT 14	SPINDLE CONTROLLER
1020	SLOT 15	CLOCKS
1030	SLOT 8	COMPUTER INTERFACE
1040	SLOT 17	MILL INTERFACE
1050	SLOT 16	M FUNCTION
1060	CONTROL CAB.	BACKPLANE
1090	PENDANT	KEYBOARD
1100-1	CONTROL CAB.	POWER DISTRIBUTION
1100-2	JUNCTION BOX	POWER DISTRIBUTION
1110	PENDANT	PENDANT POWER DISTRIBUTION
1220	CONTROL CAB.	POWER SUPPLY
1400	SLOT 5	CPU
1420	SLOT 7	VIDEO
1550	SLOT 3	TEMPATURE CONTROLLER
1560	CONTROL CAB.	CHILLER CONTROLLER
1610	SLOT 5	SOFTWARE MODULE

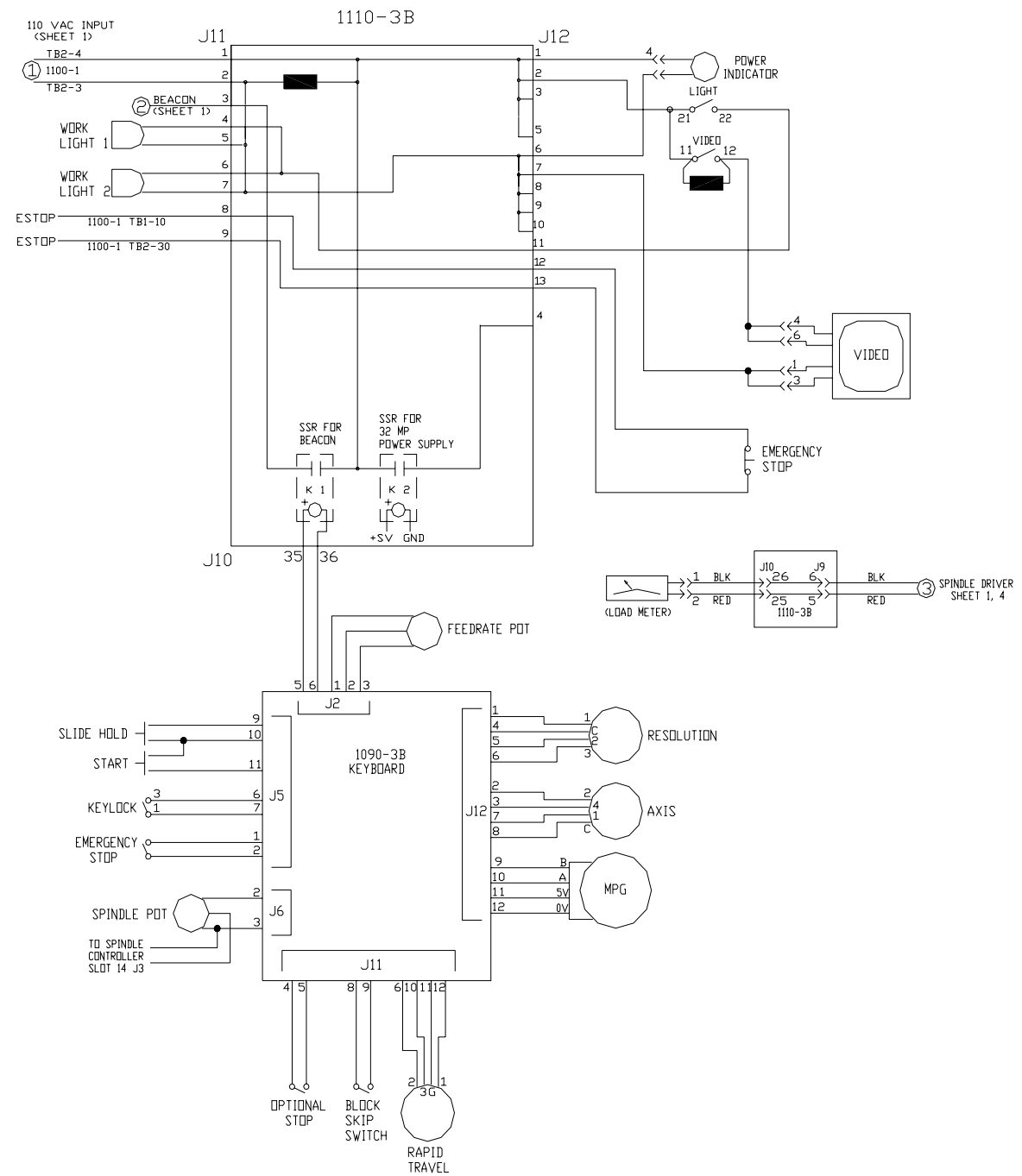

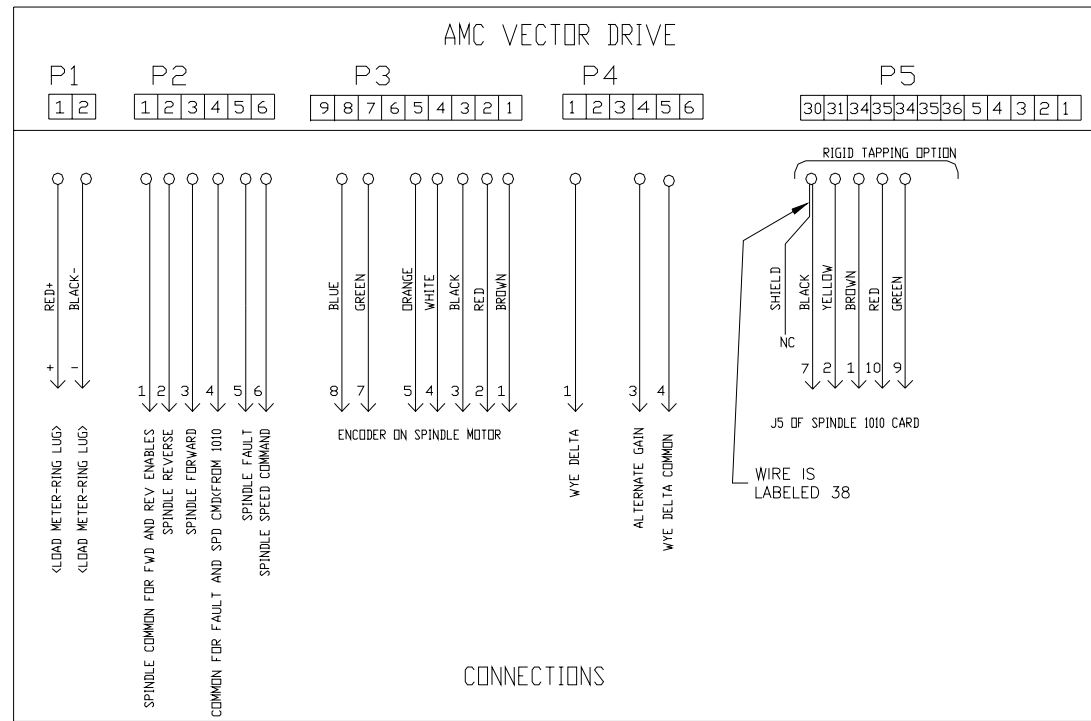
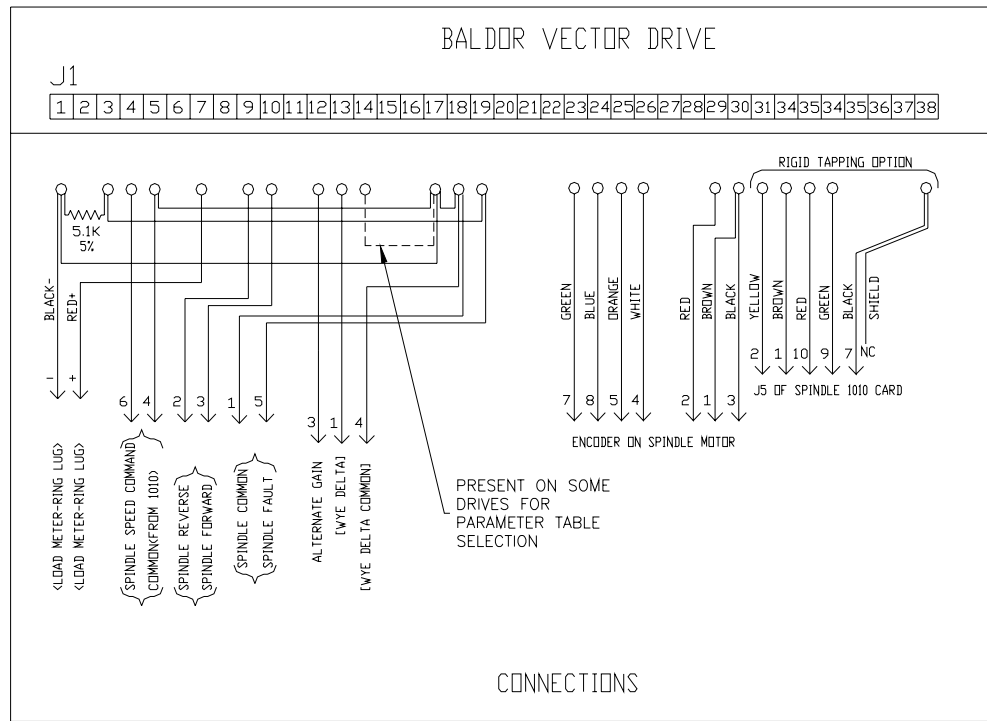

SPINDLE DRIVE BRAKE DESCRIPTION

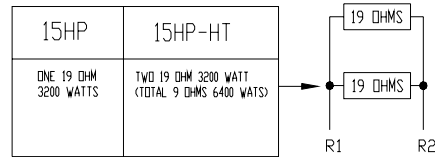

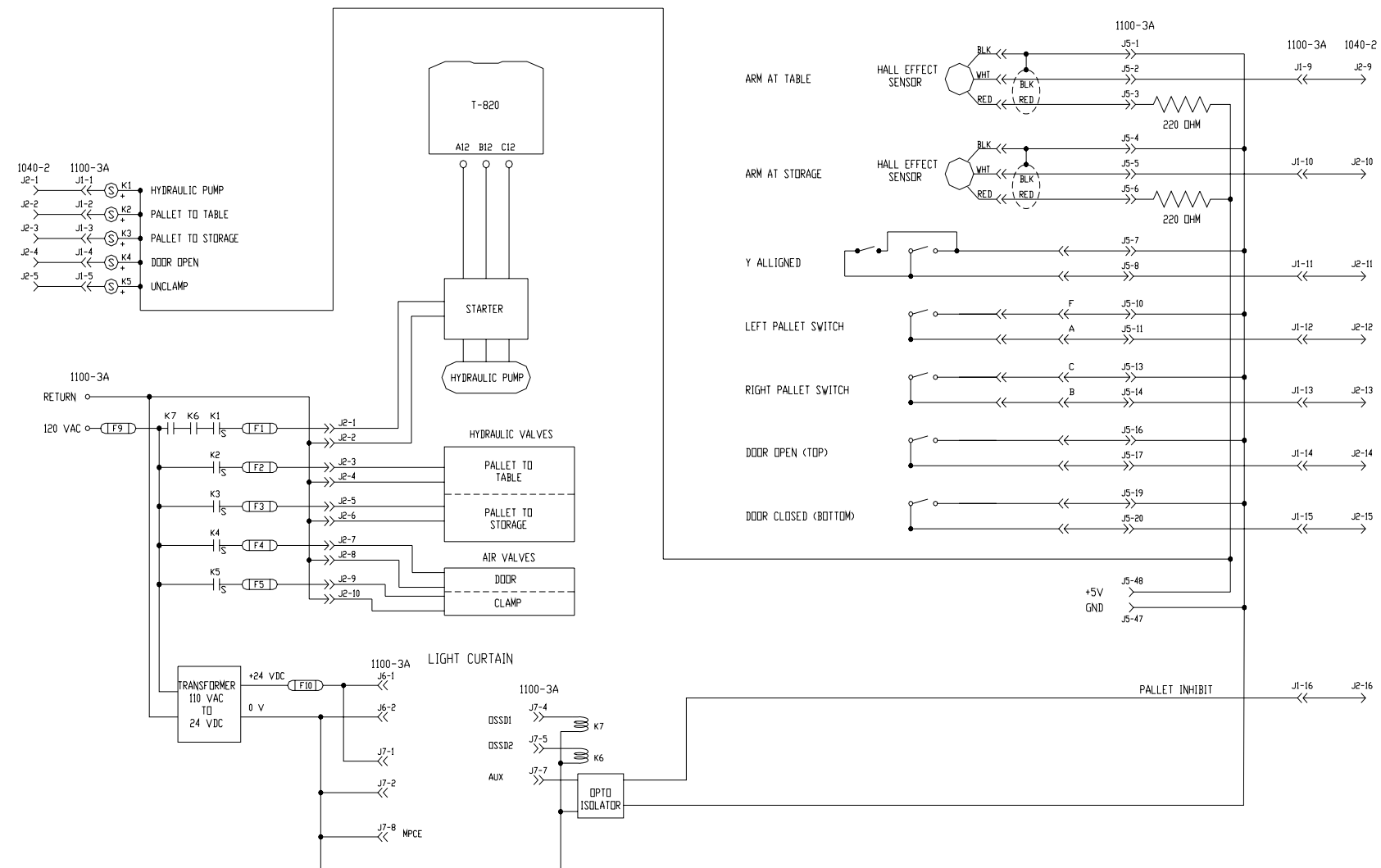

Wrg_1002C_sht_6of6_vmc_electrical

KEY TO SYMBOLS

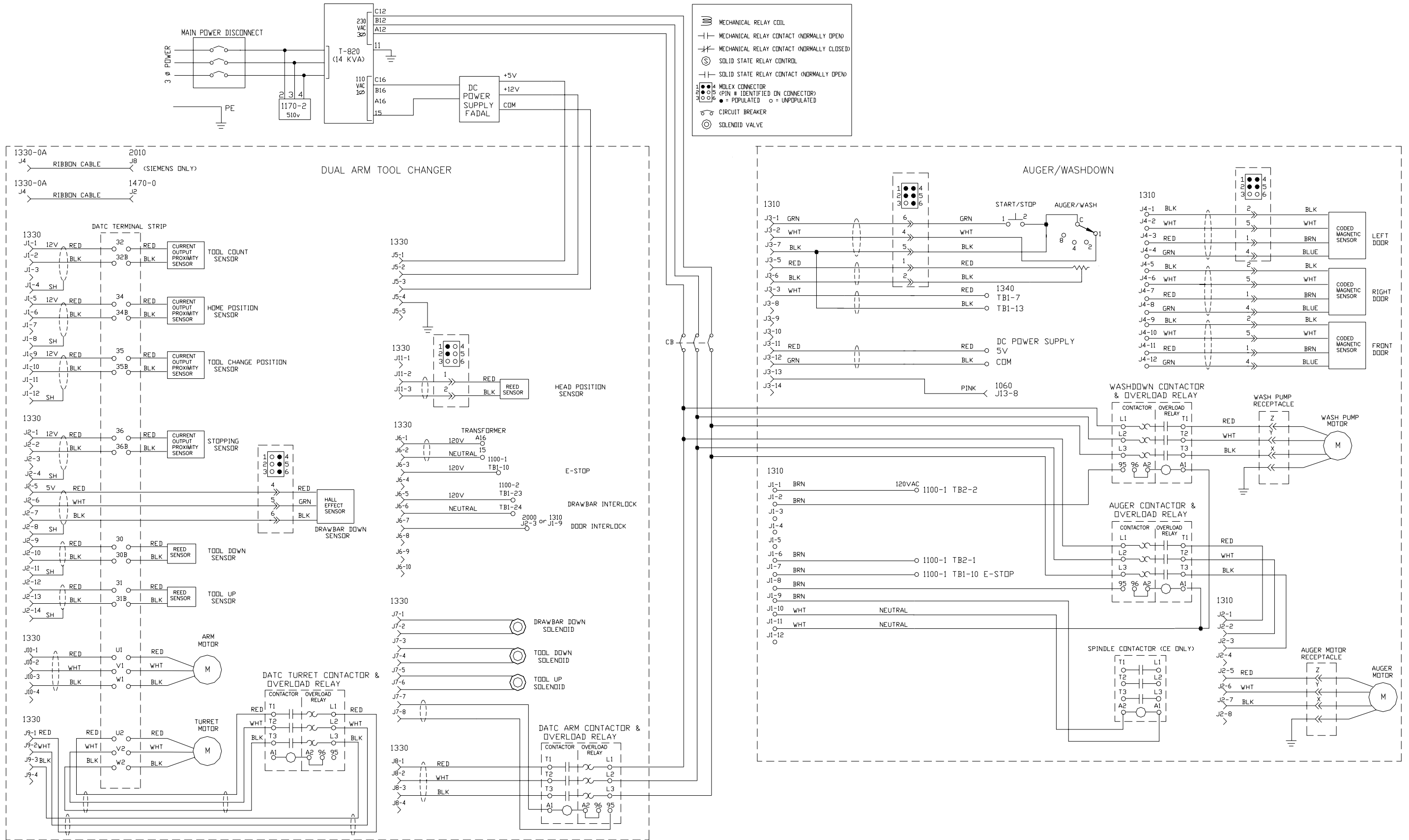
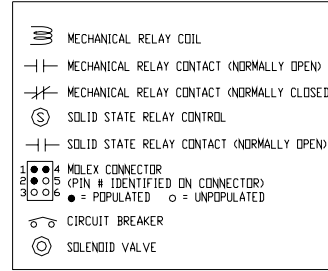

WRG_1002T_sht_1of6_vmc_electrical

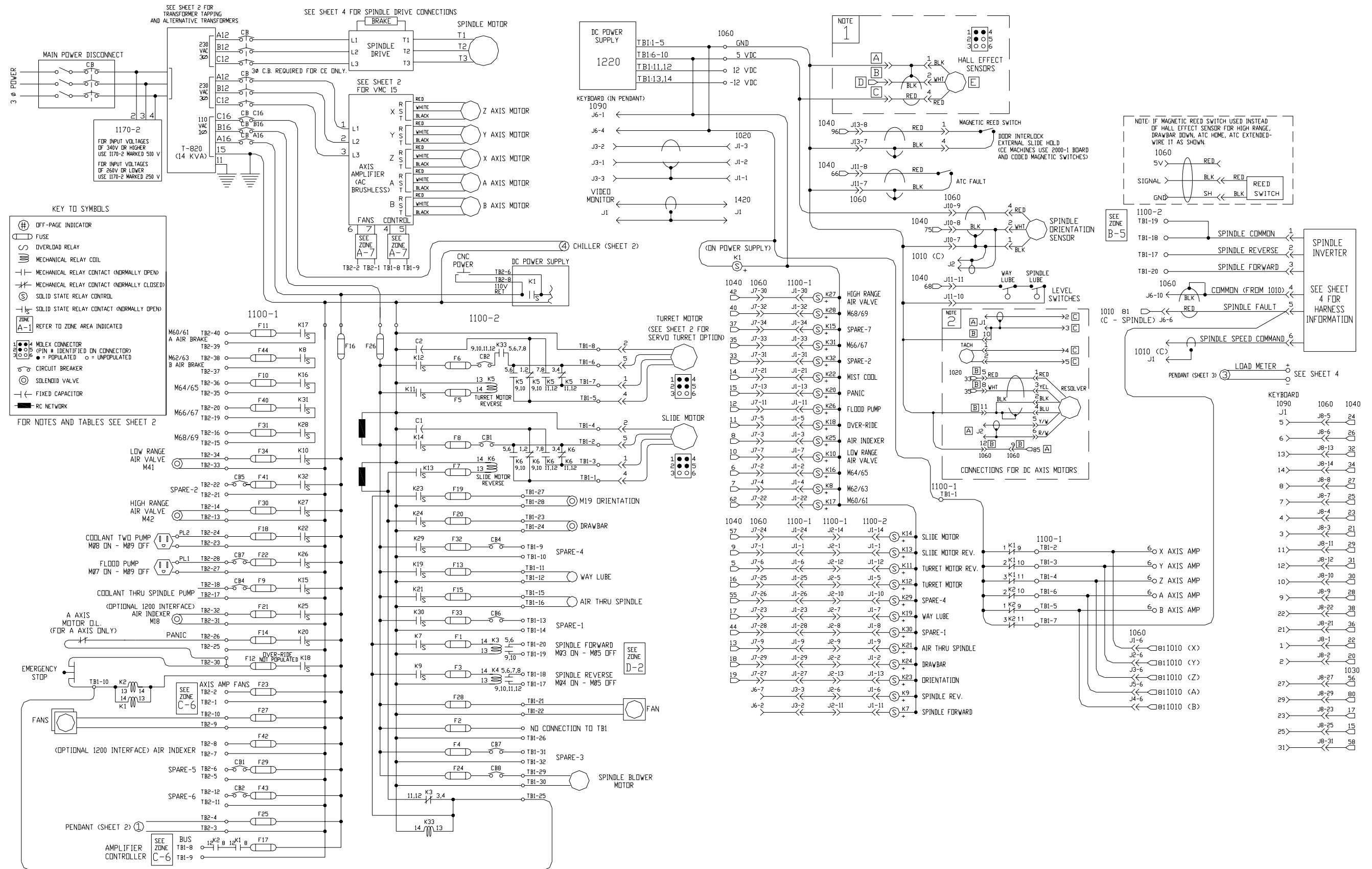

WRG_1002T_sht_2of6_vmc_electrical_Note and Option

CE TRANSFORMERS & CIRCUIT BREAKERS

TRANSFORMER DIAGRAMS:

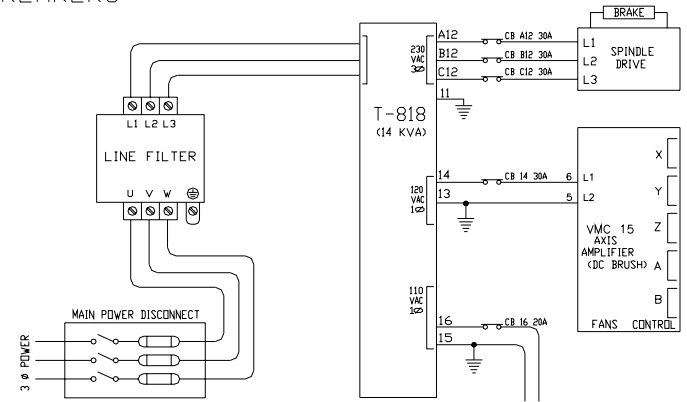
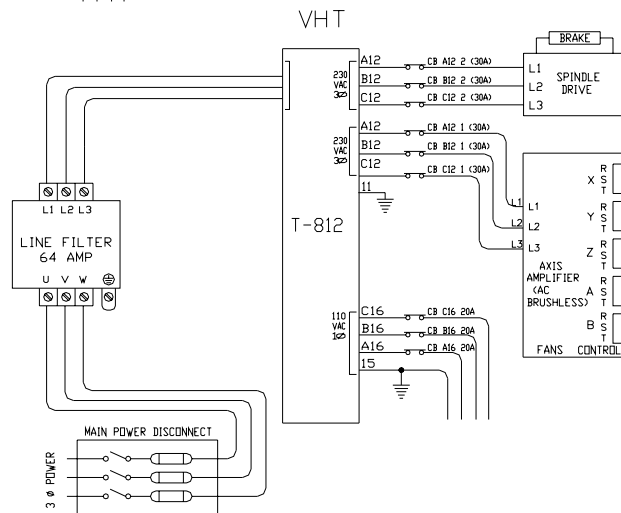
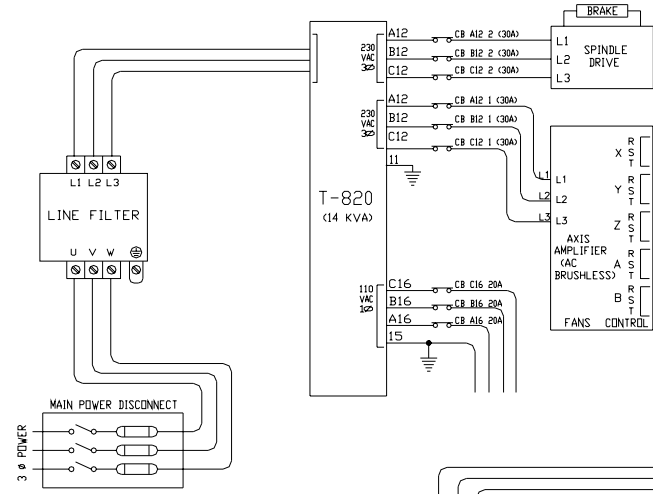
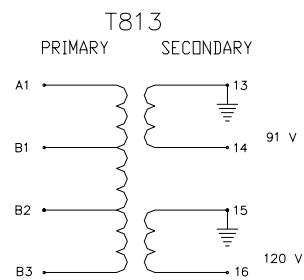
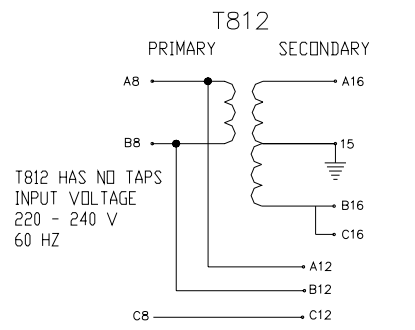
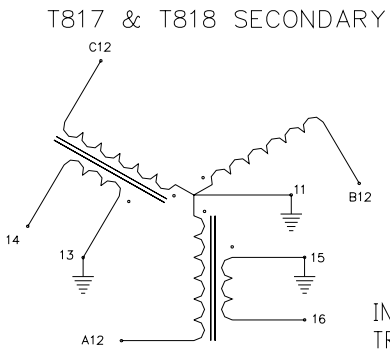
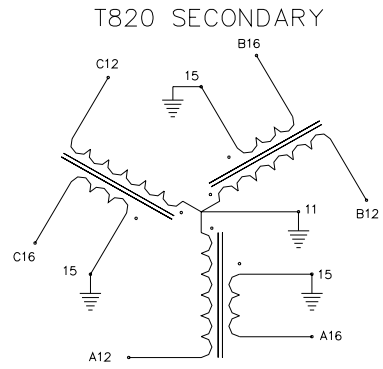

INPUT CONNECTIONS FOR MULTITAP TRANSFORMERS (EACH PHASE A, B & C)

INPUT VOLTAGE	JUMPER 3 PLS	AC INPUT
190	NONE	2
200	2-7	8
210	2-5	6
230	2-6	7
240	2-6	8
250	2-5	7
260	2-5	8
340	NONE	3
350	3-7	8
360	3-5	6
380	3-6	7
390	3-6	8
400	3-5	7
410	3-5	8
440	NONE	4
450	4-7	8
460	4-5	6
480	4-6	7
490	4-6	8
500	4-5	7
510	4-5	8

TRANSFORMER OUTPUTS

TRANSFORMER	TERMINAL	VOLTAGE
T817, T818, T820	11	GROUND FOR 240 V 3-PHASE
T817, T818, T820	A12, B12, C12	240 V 3-PHASE
T812, T820	A16, B16, C16	120 V SINGLE PHASE
T813, T817, T818	16	120 V SINGLE PHASE
ALL	15	RETURN FOR 16 (GROUNDED)
T813, T817, T818	14	120 V FOR DC AXIS AMPLIFIER CHASIS
T813, T817, T818	13	RETURN FOR 14, (GROUNDED)

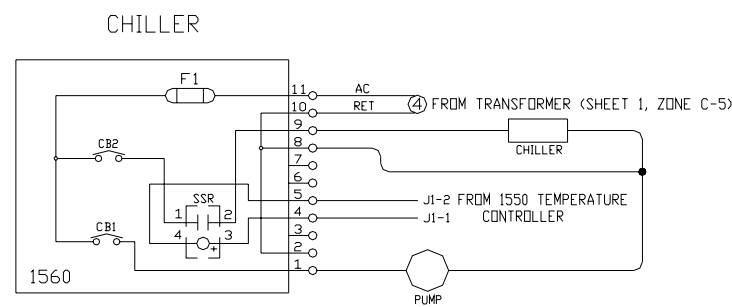

VMC 15 AXIS AMPLIFIERS

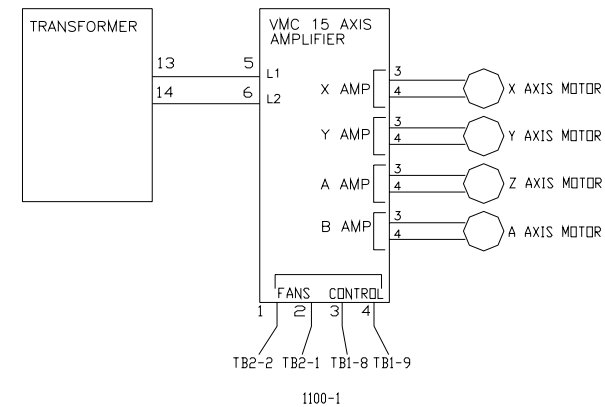

SERVO TURRET OPTION

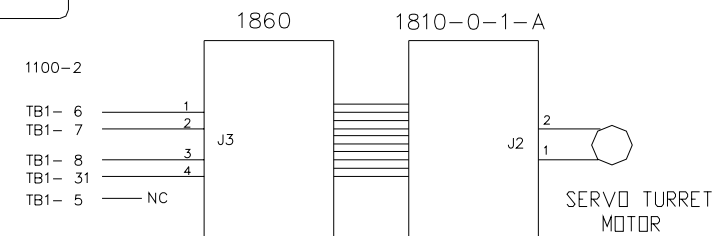

NOTES

1 SENSOR TABLE

SENSOR	1040	1060		
		A	B	C 5VDC
SLIDE EXTENDED	70	J12-1	J12-2	J12-3
SLIDE HOME	72	J12-4	J12-5	J12-6
TURRET MOTION	74	J12-7	J12-8	J12-9
DRAWBAR DOWN	50	J9-1	J9-2	J9-3
HIGH RANGE	54	J9-10	J9-11	J9-12
LOW RANGE	58	J11-4	J11-5	J11-6

2 TYPICAL OF EACH AXIS (FOR DC MOTORS ONLY)

	A	B	C
X AXIS	1010 (X)	1060 J1	X AXIS AMP
Y AXIS	1010 (Y)	1060 J2	Y AXIS AMP
Z AXIS	1010 (Z)	1060 J3	Z AXIS AMP
A AXIS	1010 (A)	1060 J5	A AXIS AMP
B AXIS	1010 (B)	1060 J4	B AXIS AMP

BOARD DESCRIPTION

BOARD #	LOCATION	FUNCTION
1010 (X)	SLOT 9	X AXIS CONTROLLER
1010 (Y)	SLOT 10	Y AXIS CONTROLLER
1010 (Z)	SLOT 11	Z AXIS CONTROLLER
1010 (A)	SLOT 13	A AXIS CONTROLLER
1010 (B)	SLOT 12	B AXIS CONTROLLER
1010 (C)	SLOT 14	SPINDLE CONTROLLER
1020	SLOT 15	CLOCKS
1030	SLOT 8	COMPUTER INTERFACE
1040	SLOT 17	MILL INTERFACE
1050	SLOT 16	M FUNCTION
1060	CONTROL CAB.	BACKPLANE
1090	PENDANT	KEYBOARD
1100-1	CONTROL CAB.	POWER DISTRIBUTION
1100-2	JUNCTION BOX	POWER DISTRIBUTION
1110	PENDANT	PENDANT POWER DISTRIBUTION
1220	CONTROL CAB.	POWER SUPPLY
1400	SLOT 5	CPU
1420	SLOT 7	VIDEO
1550	SLOT 3	TEMPATURE CONTROLLER
1560	CONTROL CAB.	CHILLER CONTROLLER
1610	SLOT 5	SOFTWARE MODULE

WRG_1002T_sht_4of6_vmc_electrical_Spindle Drive Connections

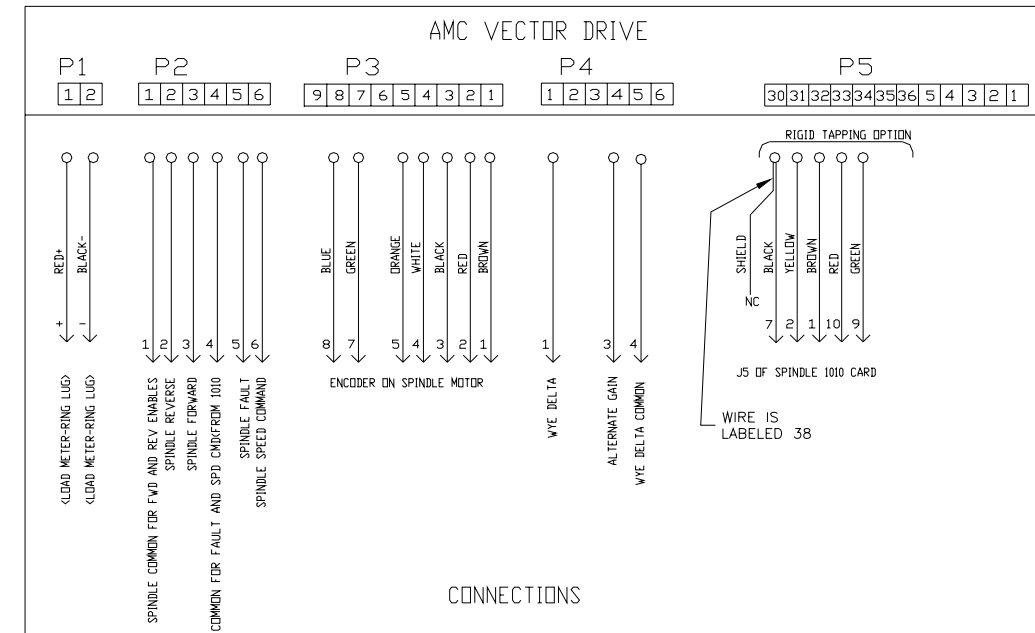
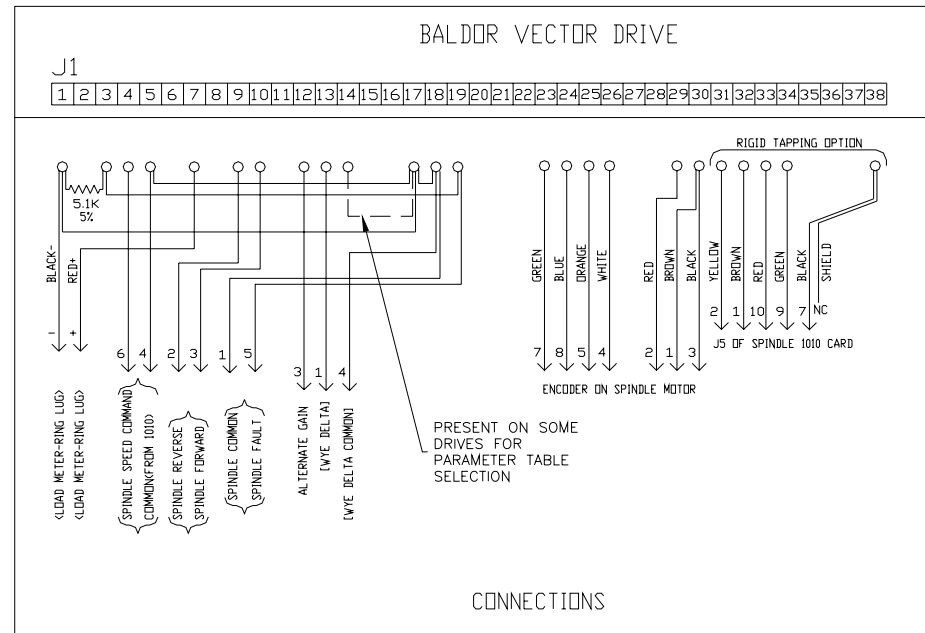

SPINDLE DRIVE BRAKE DESCRIPTION

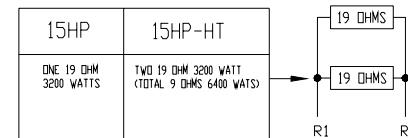

WRG_1002T_sht_5of6_vmc_electrical_Pallet Changer

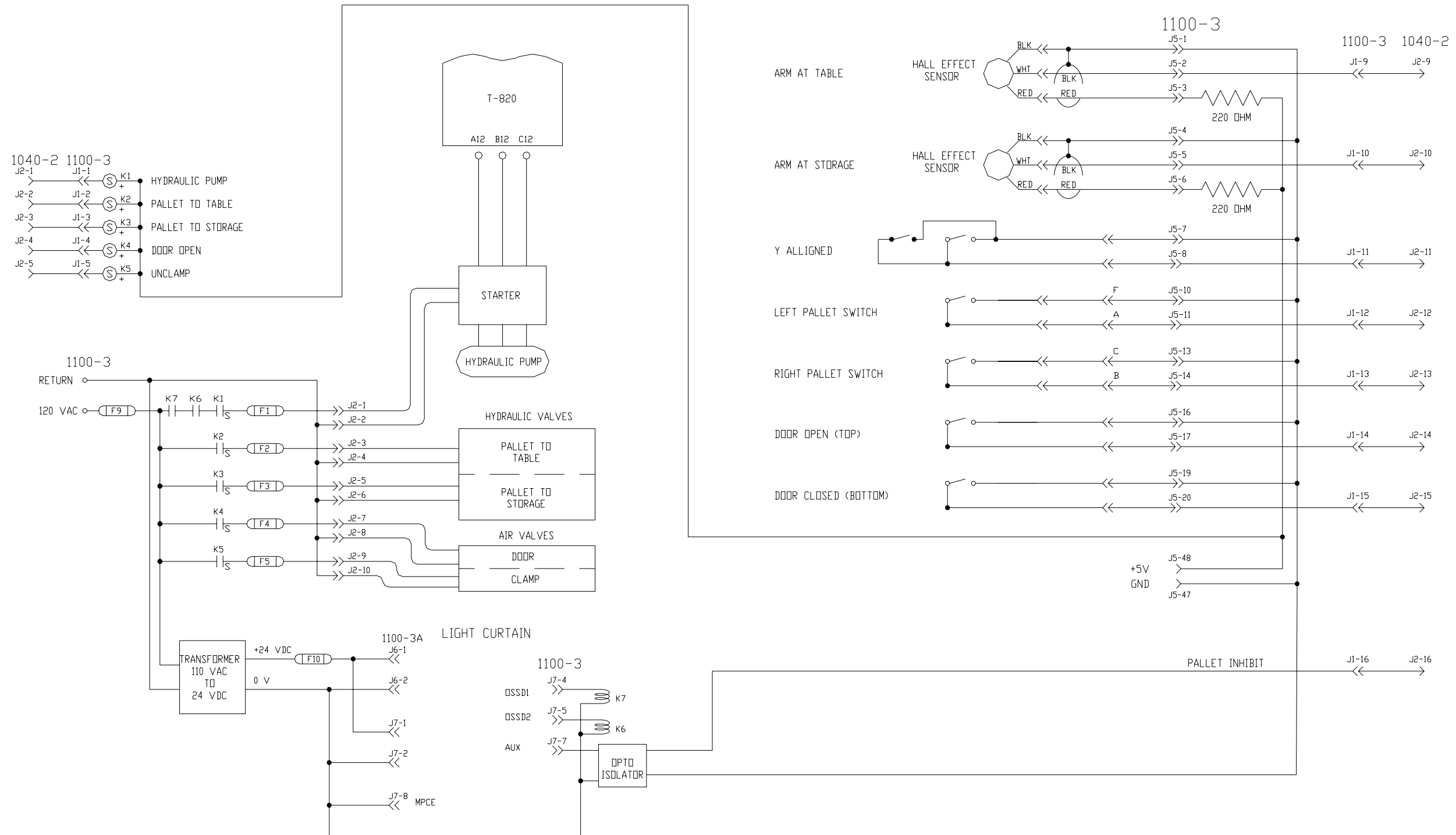

WRG_1002T_sht_6of6_vmc_electrical_Dual Arm and Auger

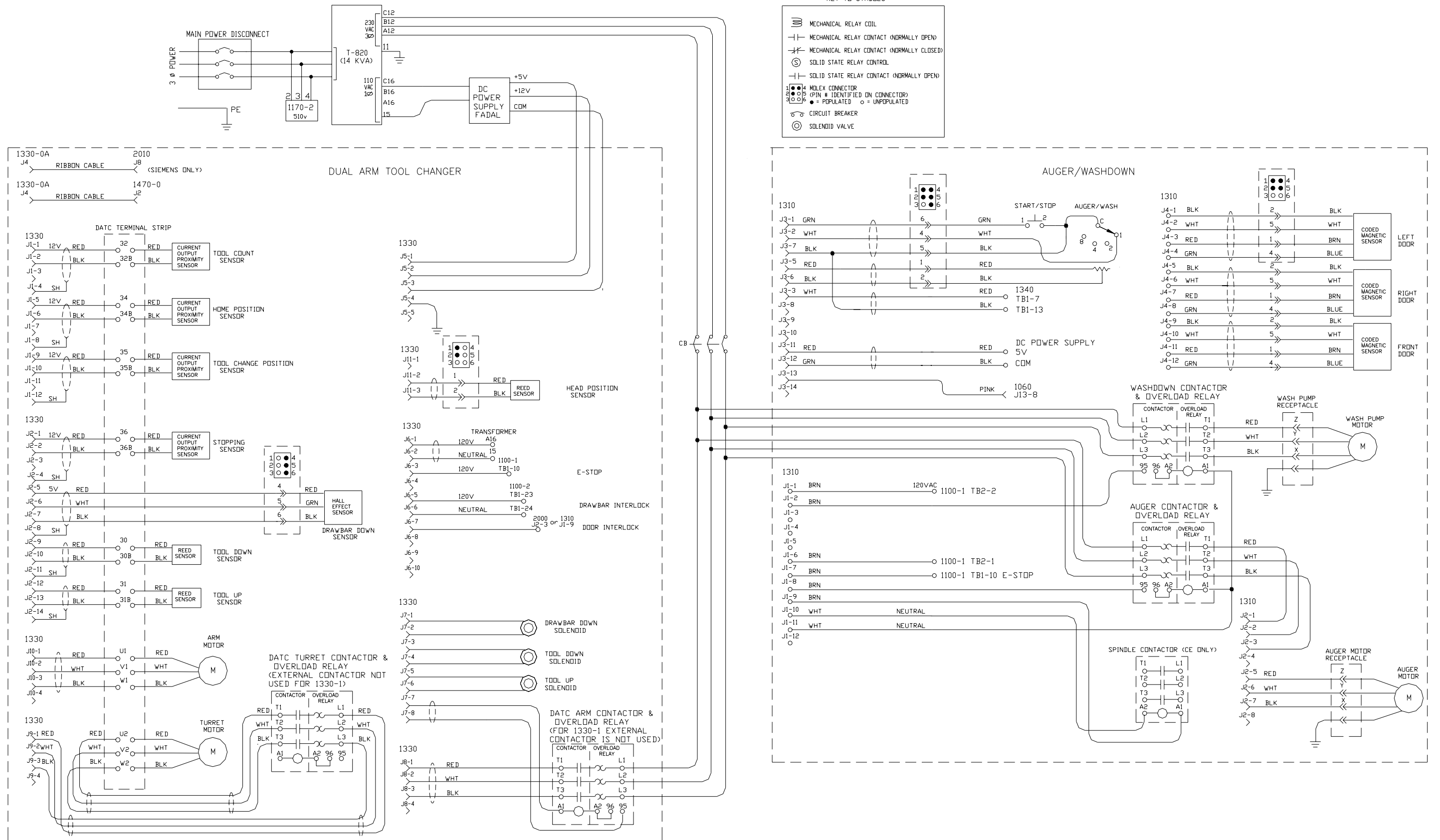

WRG_0030C_vmc_ac_brushless_power

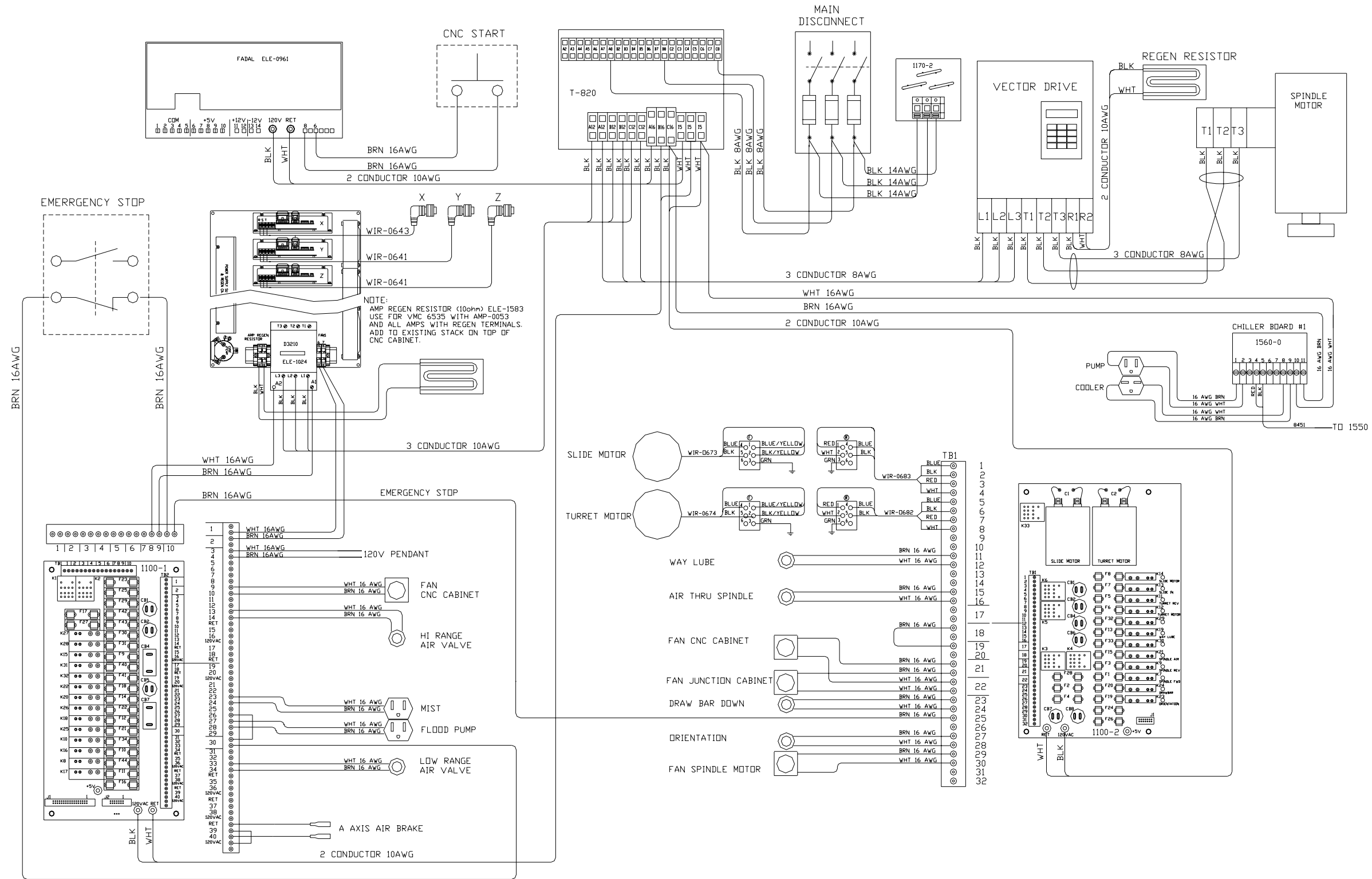

Wrg_0058B_vmc_ac_brushless_control

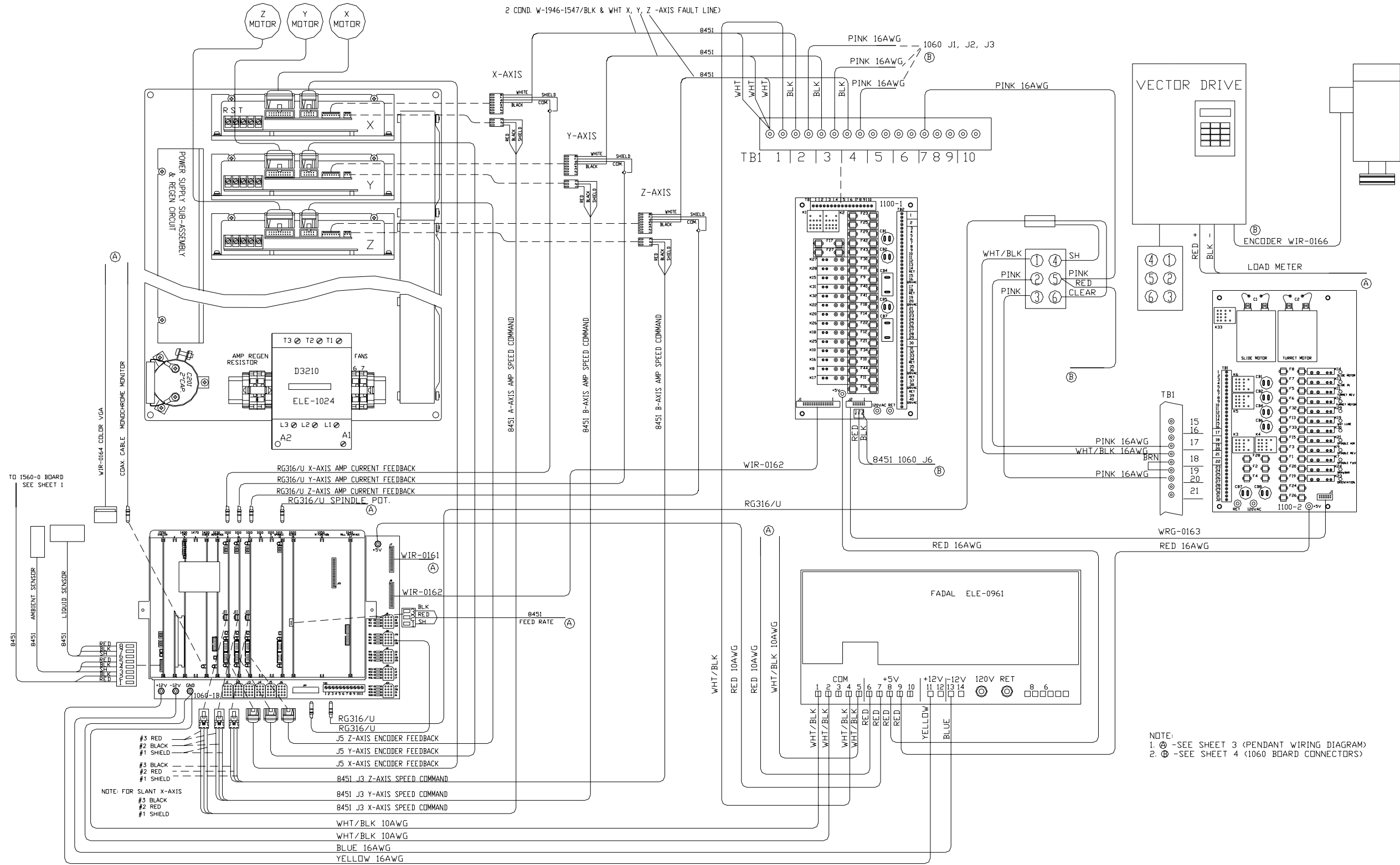

Wrg_0059B_vmc_ac_brushless_pendant

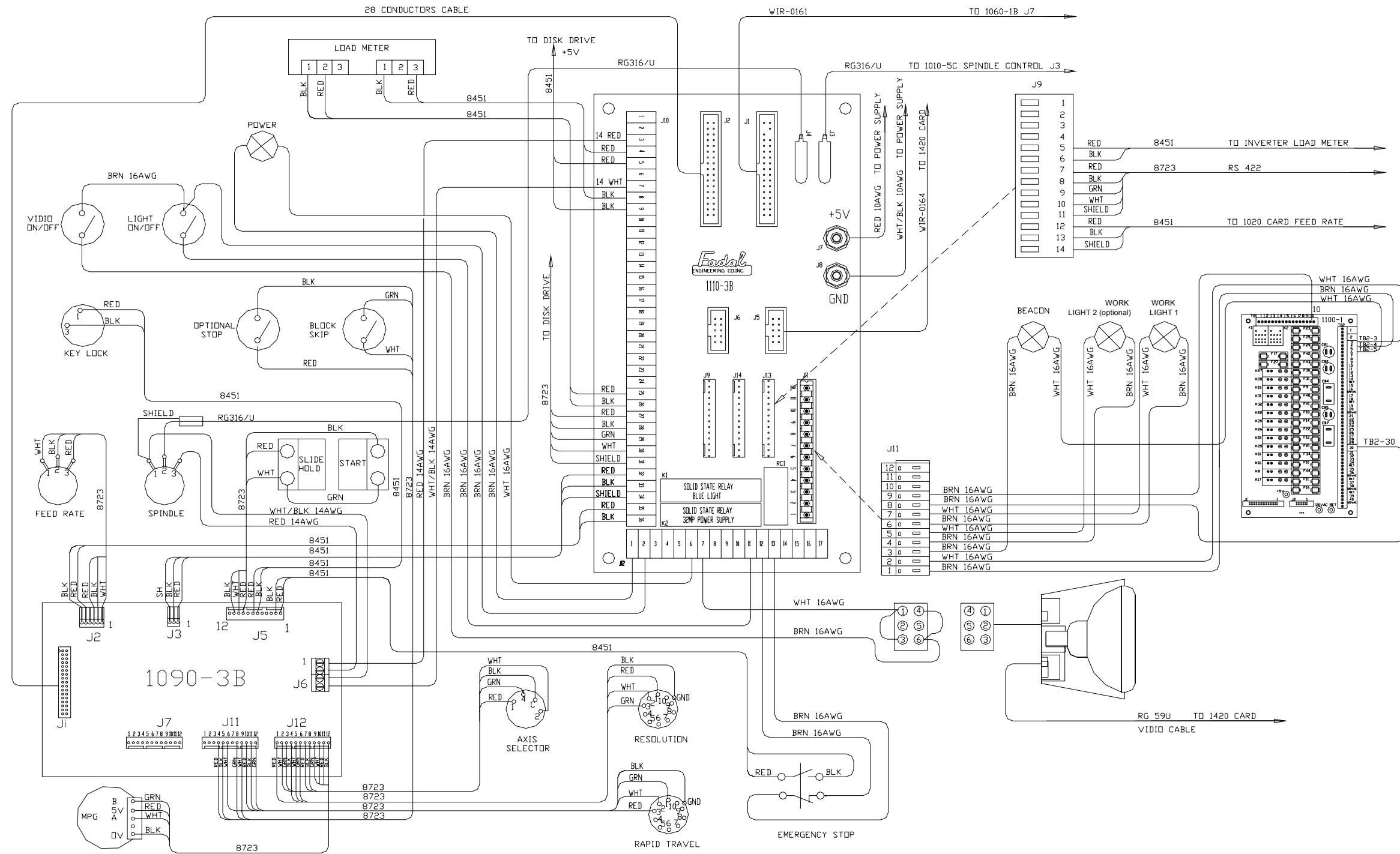

Wrg_0064B_vmc_ac_brushless_connectors

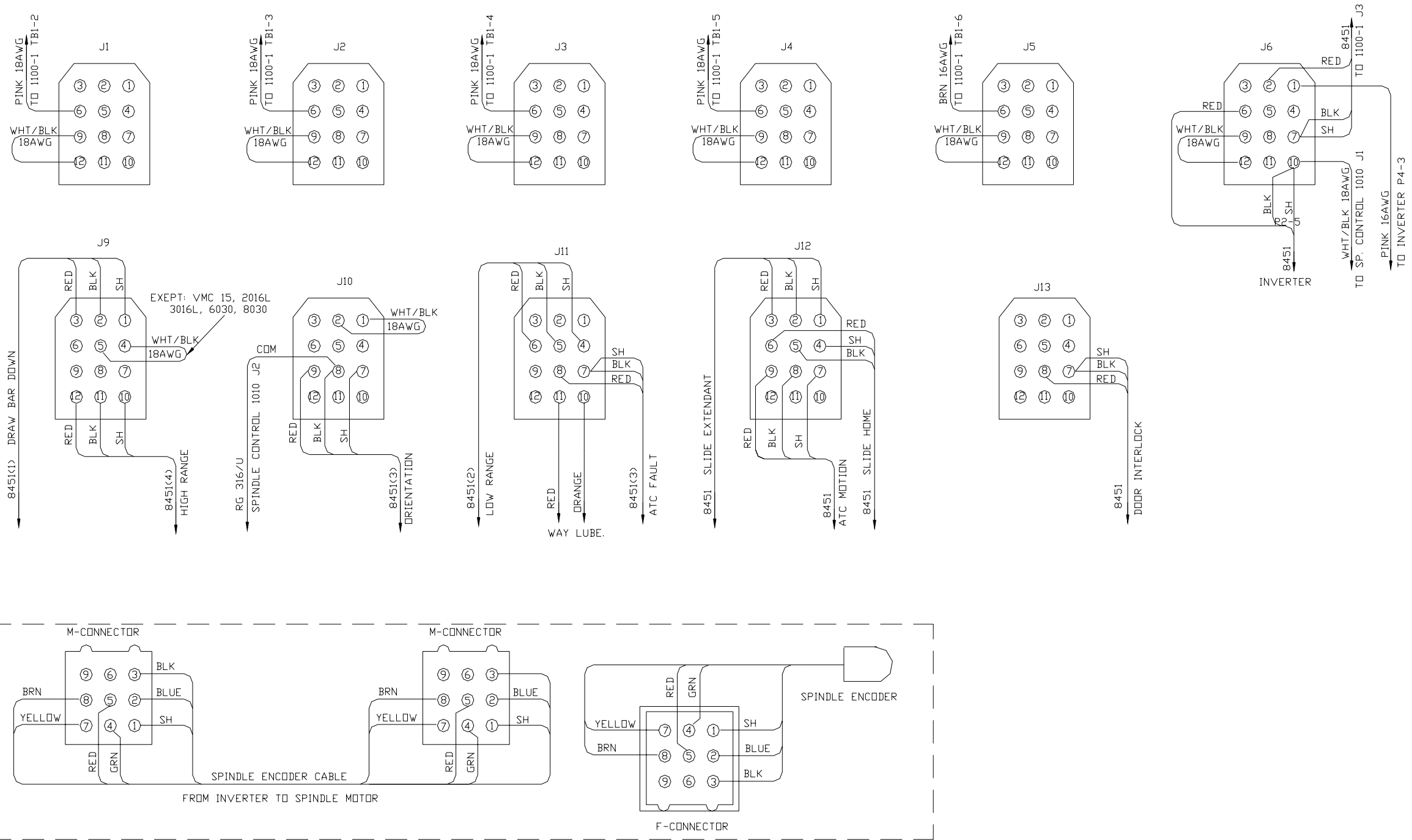

Wrg_0065B_vmc_ac_brushless_options

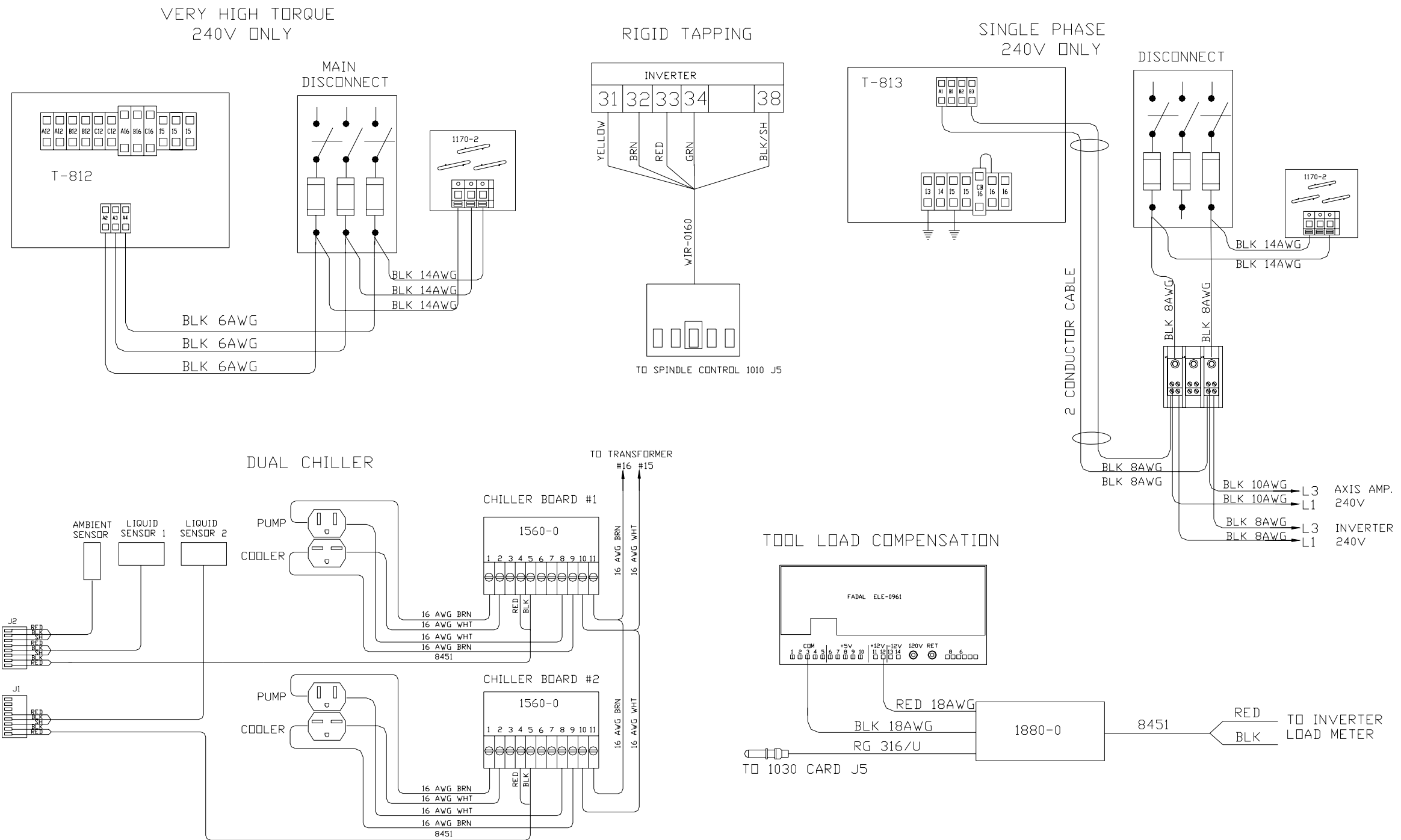

Wrg_0696C_ce_door_interlock_wiring_diagram_ac_brushless_sheet_1of3

2000-1 PIN LIST

- J1**
- 1. DOOR SWITCH (BLACK)
 - 2. DOOR SWITCH (WHITE)
 - 3. DOOR SWITCH (RED)
 - 4. DOOR SWITCH (GREEN)
 - 5. DOOR SWITCH (BLACK)
 - 6. DOOR SWITCH (WHITE)
 - 7. DOOR SWITCH (RED)
 - 8. DOOR SWITCH (GREEN)
 - 9. DOOR SWITCH (BLACK)
 - 10. DOOR SWITCH (WHITE)
 - 11. DOOR SWITCH (RED)
 - 12. DOOR SWITCH (GREEN)
 - 13.
 - 14.
 - 15. +5V
 - 16. REMOTE SLIDE HOLD
 - 17. GROUND
- J2**
- 1. TB2-1 (WHITE)
 - 2. CONTACTOR (WHITE)
 - 3. CONTACTOR (BROWN)
 - 4.
 - 5. TB1-10 (BROWN)
 - 6. TB2-2 (BROWN)

- NOTE:
1. DISCONNECT SPINDLE DRIVE WIRES A12, B12, C12 FROM TRANSFORMER AND CONNECT THEM TO L1, L2, L3 ON SPINDLE DRIVE CONTACTOR (ON SLANT '98 DISCONNECT FROM SPINDLE DRIVE)
 2. CONNECT SPINDLE DRIVE CONTACTOR TERMINALS T1, T2, T3 TO TRANSFORMER A12, B12, C12 (8 AWG) (PART OF KIT)
 3. DISCONNECT AXIS AMPLIFIER WIRES A12, B12, C12 FROM TRANSFORMER AND CONNECT THEM TO TERMINALS L1, L2, L3 ON AMPLIFIER CONTACTOR (ON SLANT '98 DISCONNECT FROM AXIS AMPLIFIER)
 4. CONNECT AXIS AMPLIFIER CONTACTOR TERMINALS T1, T2, T3 TO TRANSFORMER A12, B12, C12 (PART OF KIT)

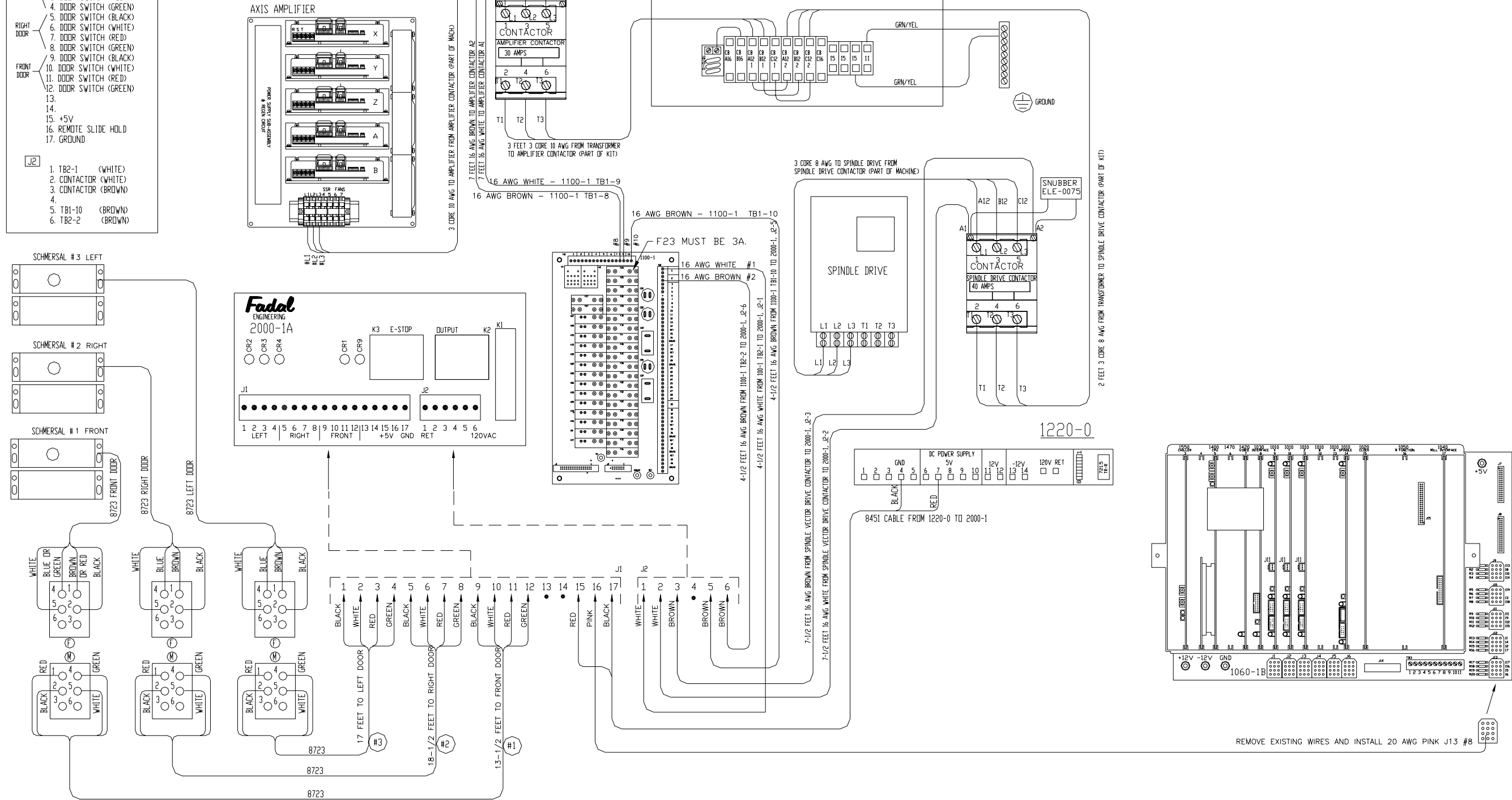

- Ⓢ CONNECTOR HAS PINS
- Ⓜ CONNECTOR HAS SOCKETS

REMOVE EXISTING WIRES AND INSTALL 20 AWG PINK J13 #8

Wrg_0696C_ce_door_interlock_wiring_diagram_dc_machine_sheet_2of3

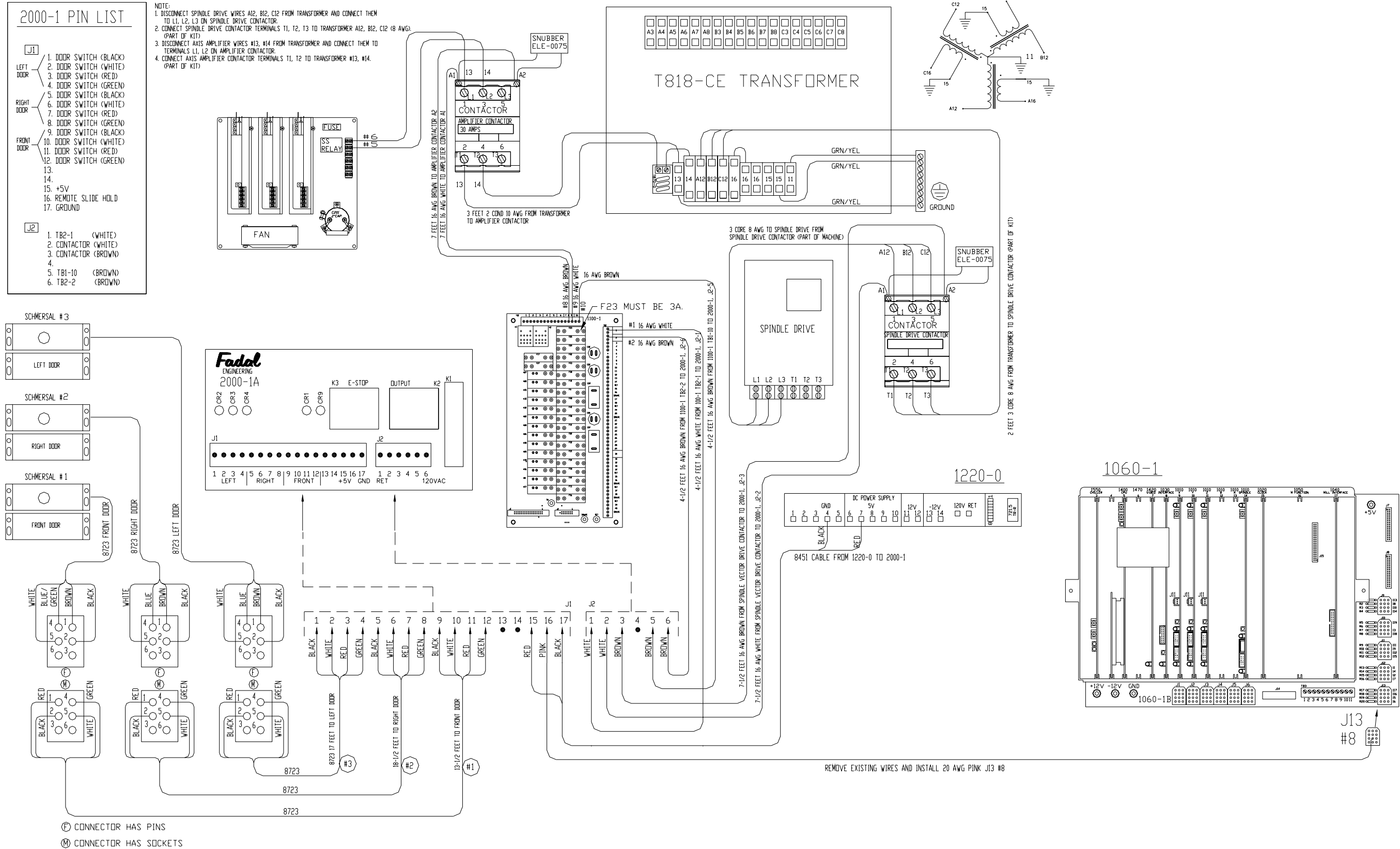

Wrg_0696B_ce_door_interlock_wiring_diagram_4th_5th_axis_sheet_3of3

FOR CONNECTION TO BRUSHLESS SYSTEM:

INPUT 1 - BROWN 16 GA. WIRE TO 1100-1 TB2-2
 INPUT 2 - WHITE 16 GA. WIRE TO 1100-1 TB2-1

INPUT 3 - BROWN 16 GA. WIRE TO INPUT 5 ON BRUSHLESS CHASSIS
 INPUT 4 - WHITE 16 GA. WIRE TO INPUT 4 ON BRUSHLESS CHASSIS

INPUT 5 - BROWN 10 GA. WIRE TO 120VAC TERMINAL ON 1100-1
 INPUT 6 - WHITE 10 GA. WIRE TO RET TERMINAL ON 1100-1

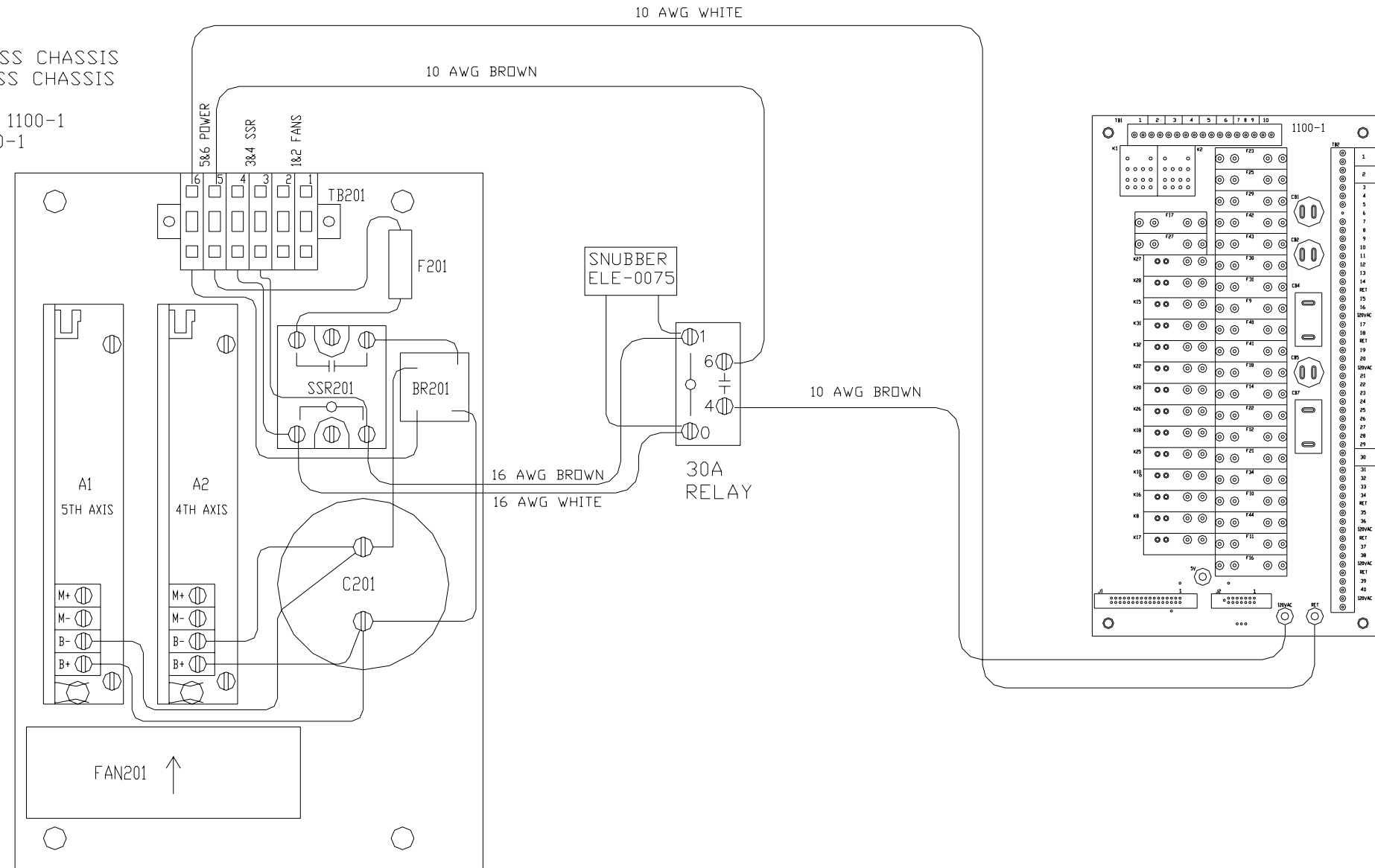

Wrg_0041F_ce_door_lock_2030-0A_wiring_diagram_1of3

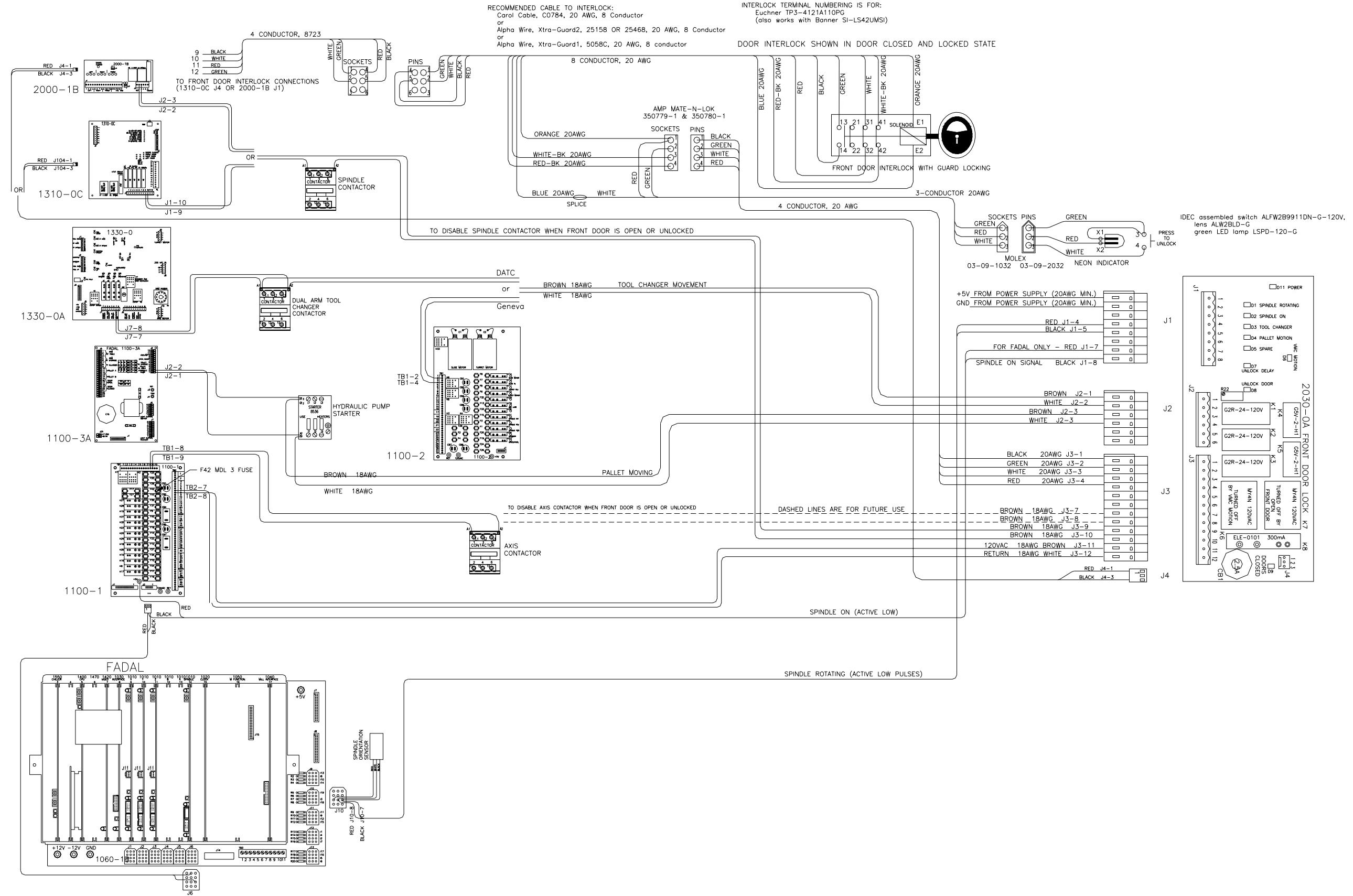

WRG_0040C_coolant_pump

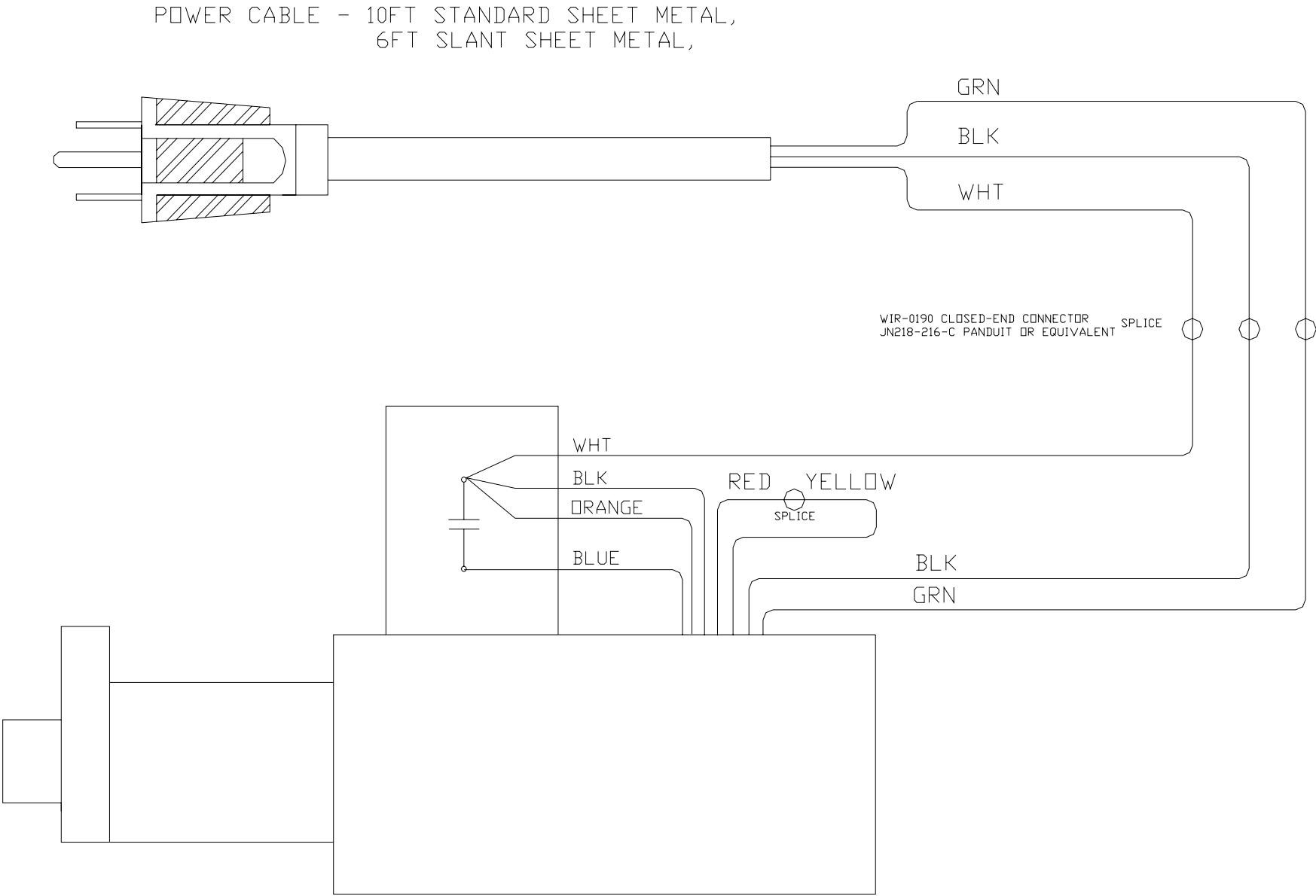

SECTION 2

Spindle

WRG_0023E_wye_delta_contactors

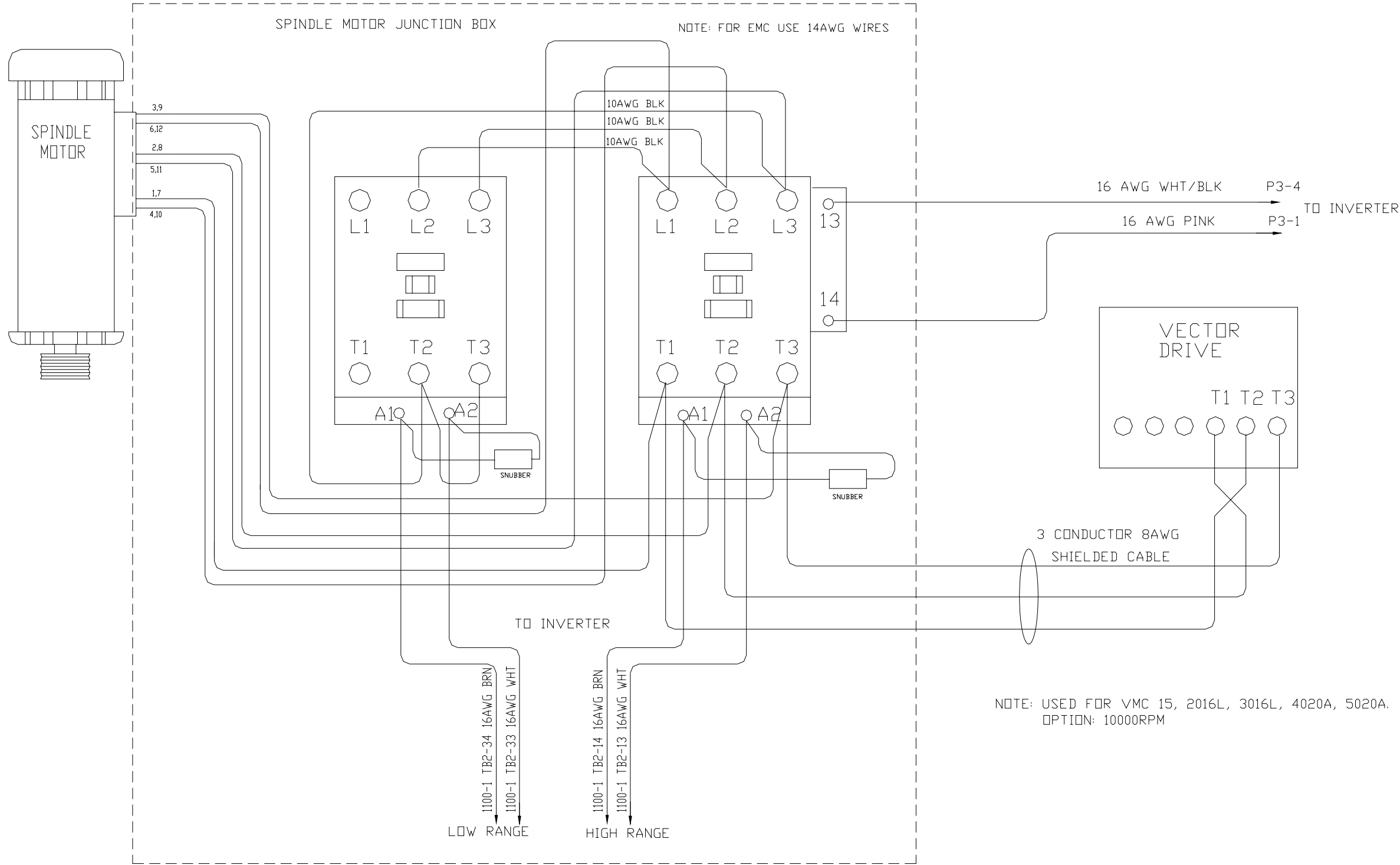

Wrg_0024A_spindle_motor_connection

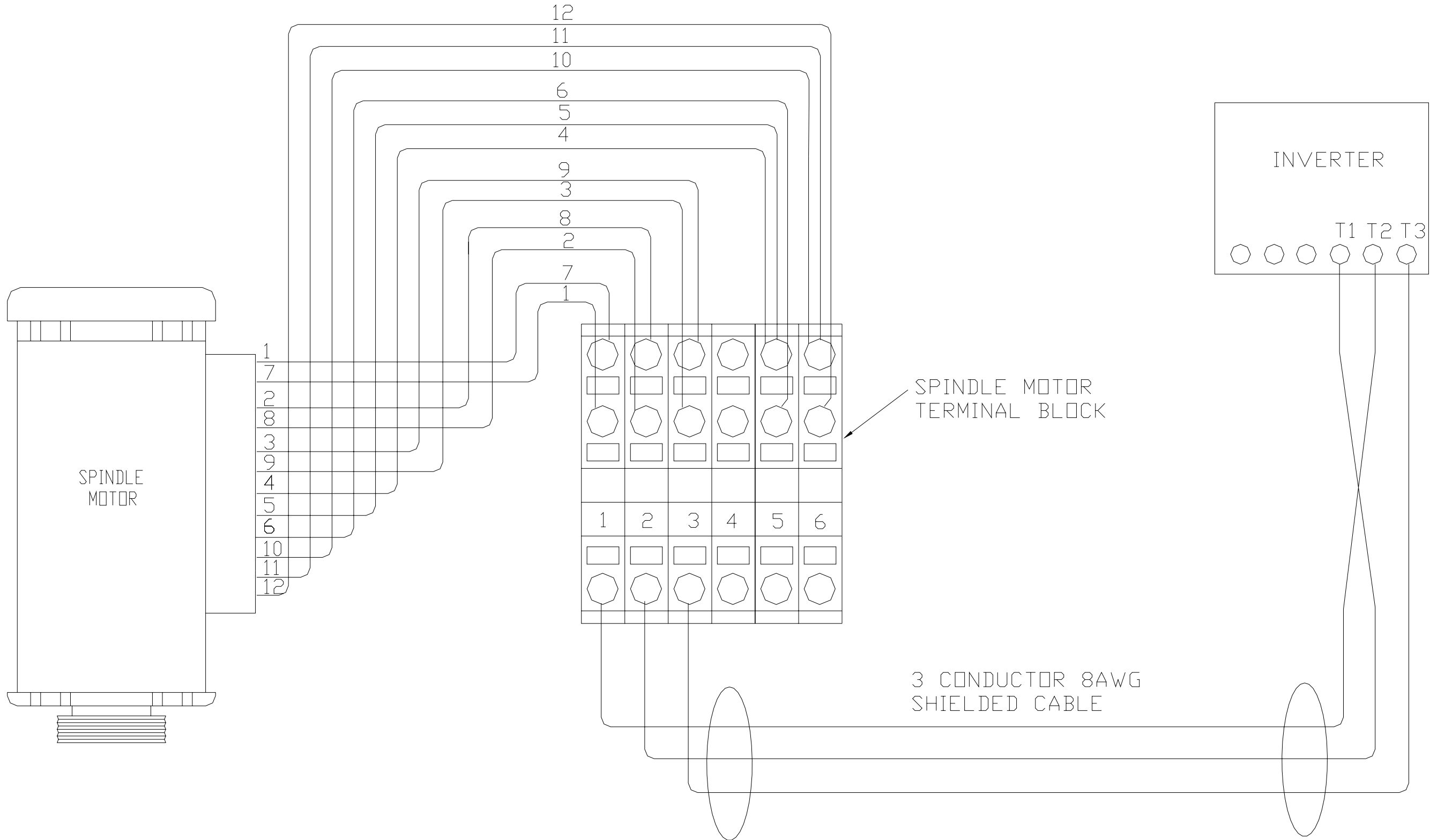

FOR VMC 2216, 3016, 3020, 4020, 6030, 8030.

WRG_0043A_encoder_cable_E5D

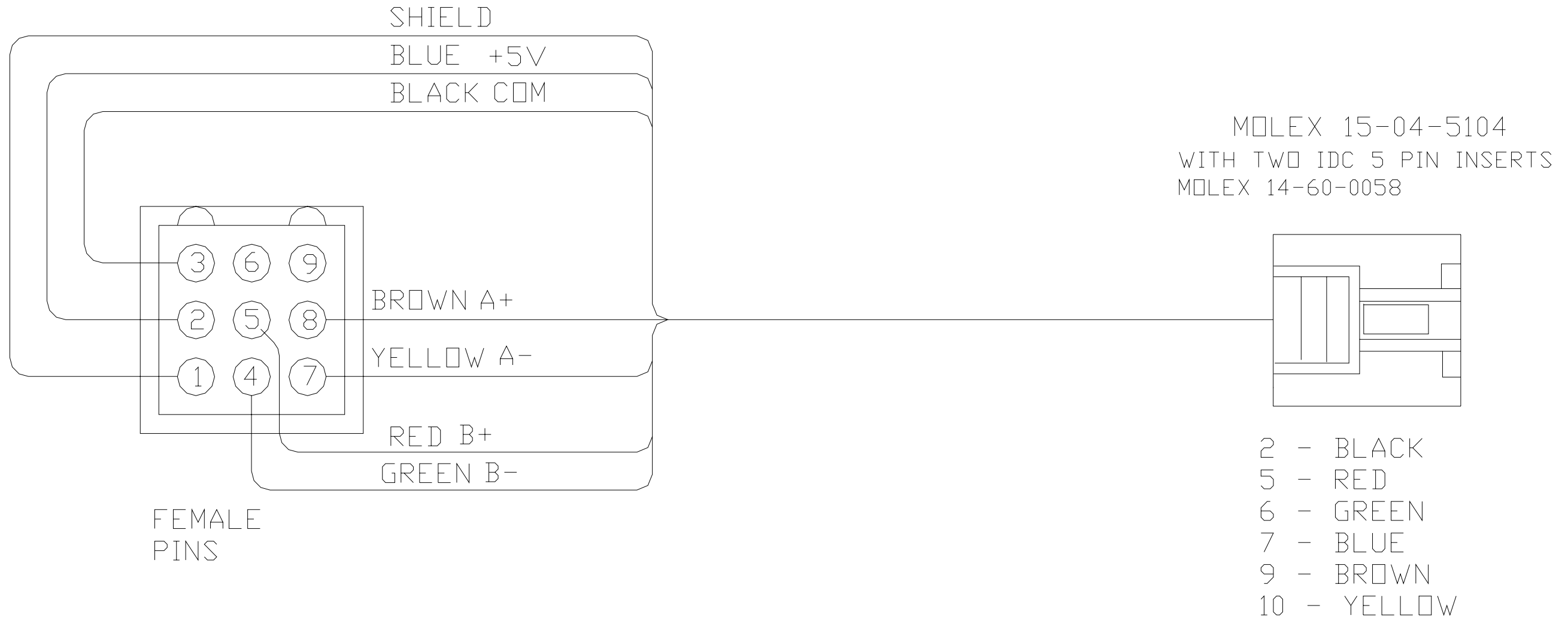

WRG_0046C_Tool_IO_switch_on_spindle

Connection of 1705-0A is the same for all keyboards.

1090-5C and 1090-6C do not use 1705-0A board.

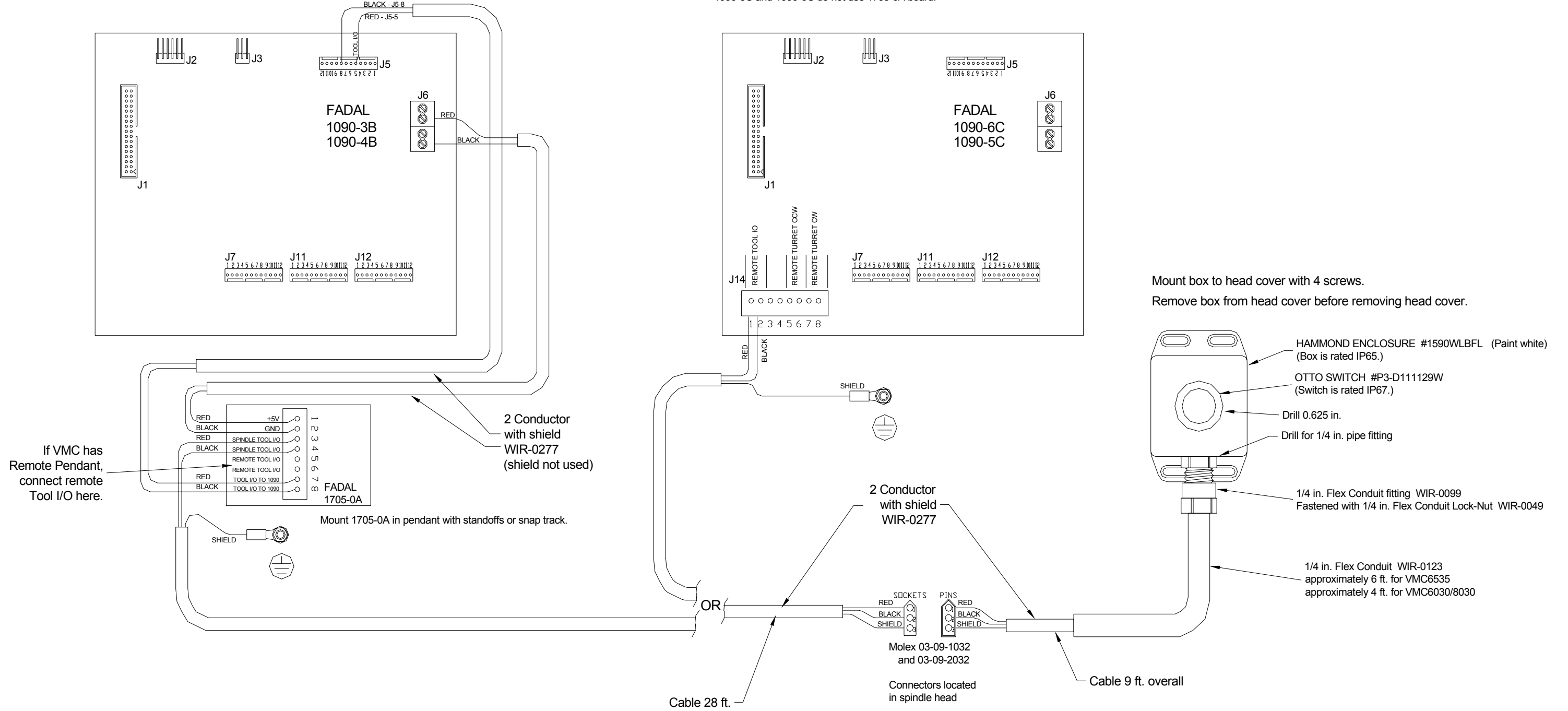

Installation procedure is given in FSP-W1042.

SECTION 3

4th & 5th Axis/Servo Options

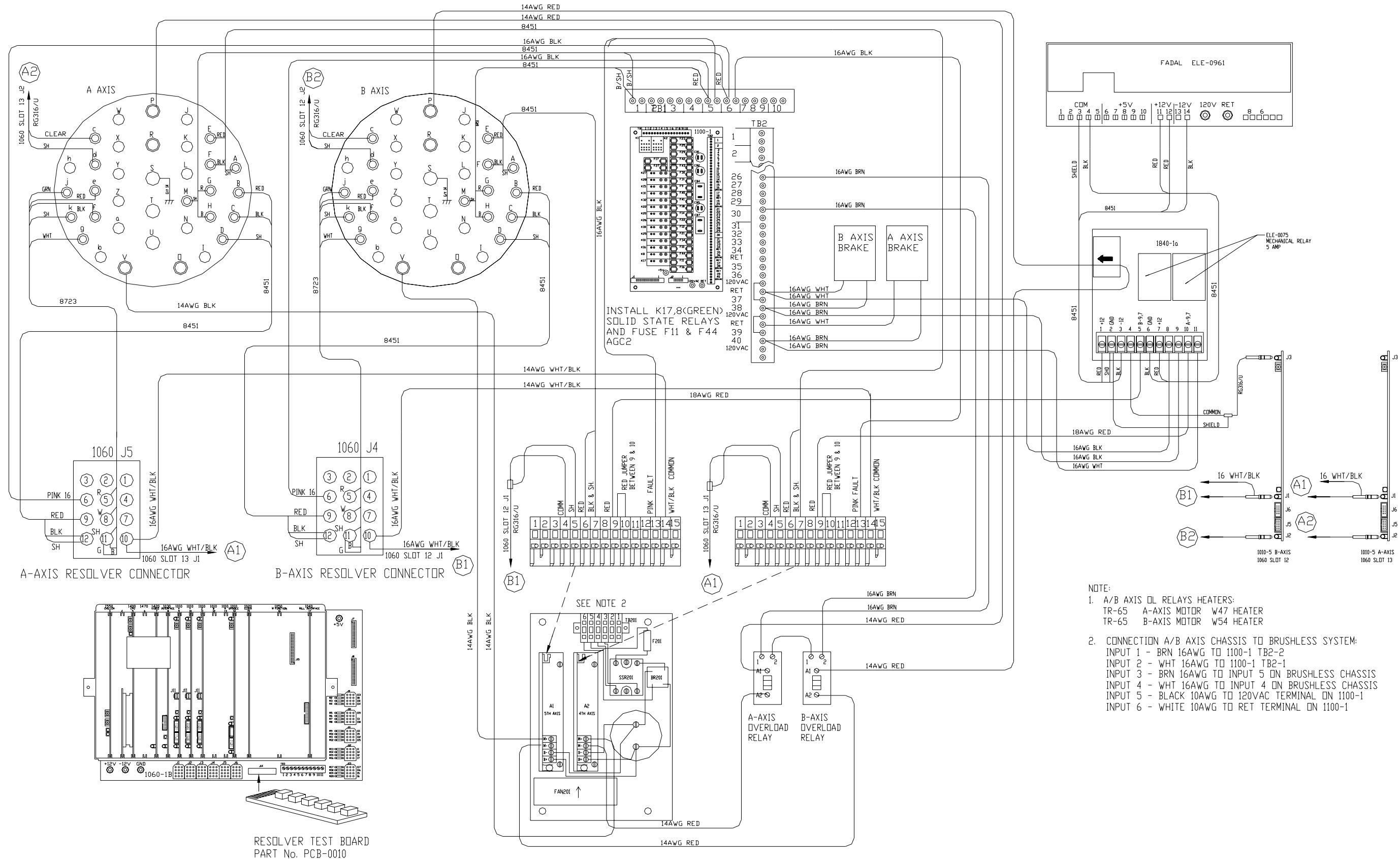

Wrg_0034A_dc_4axis_for_ac

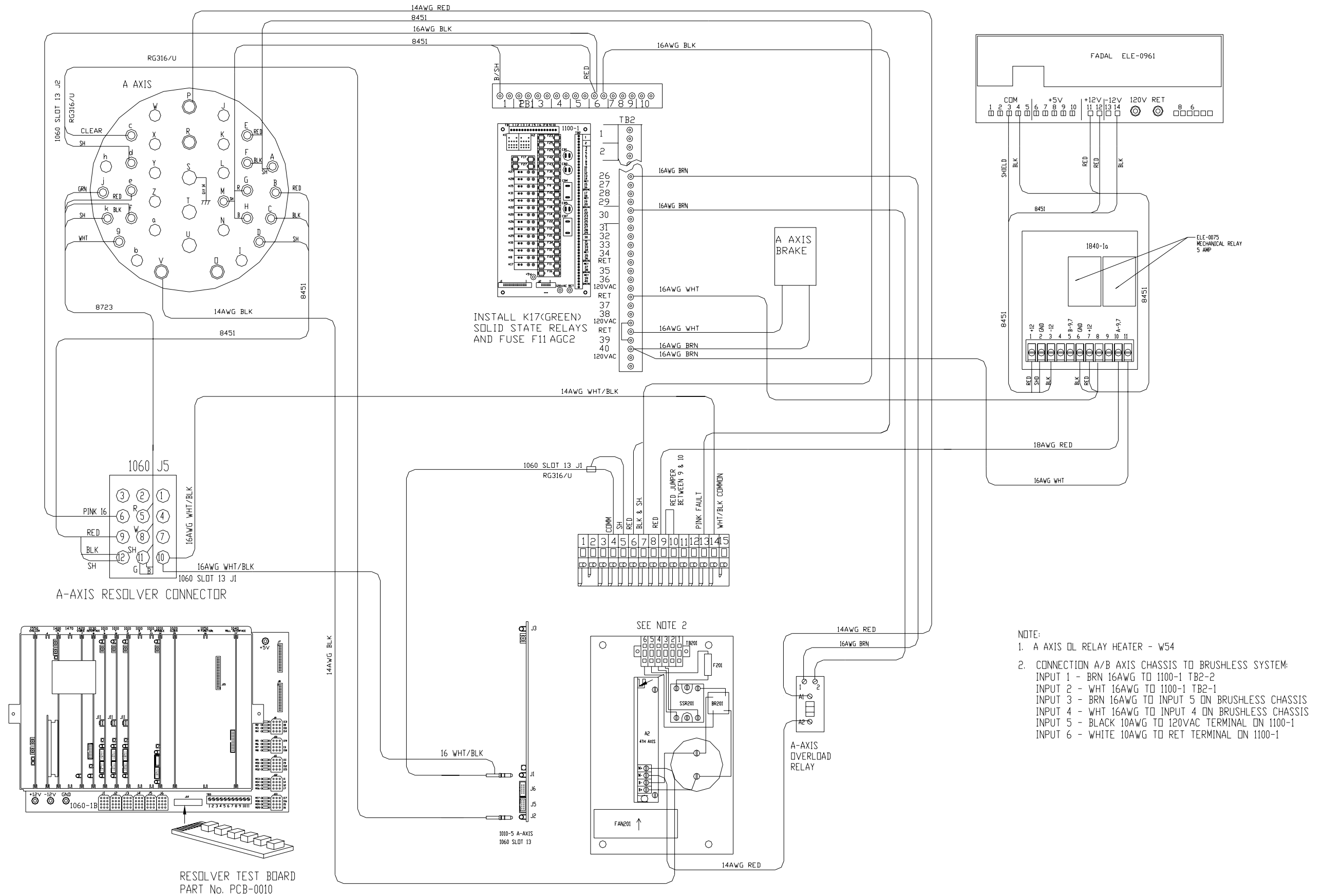

Wrg_0014C_ac_4th_axis_for_ac_brushless_std_slant98

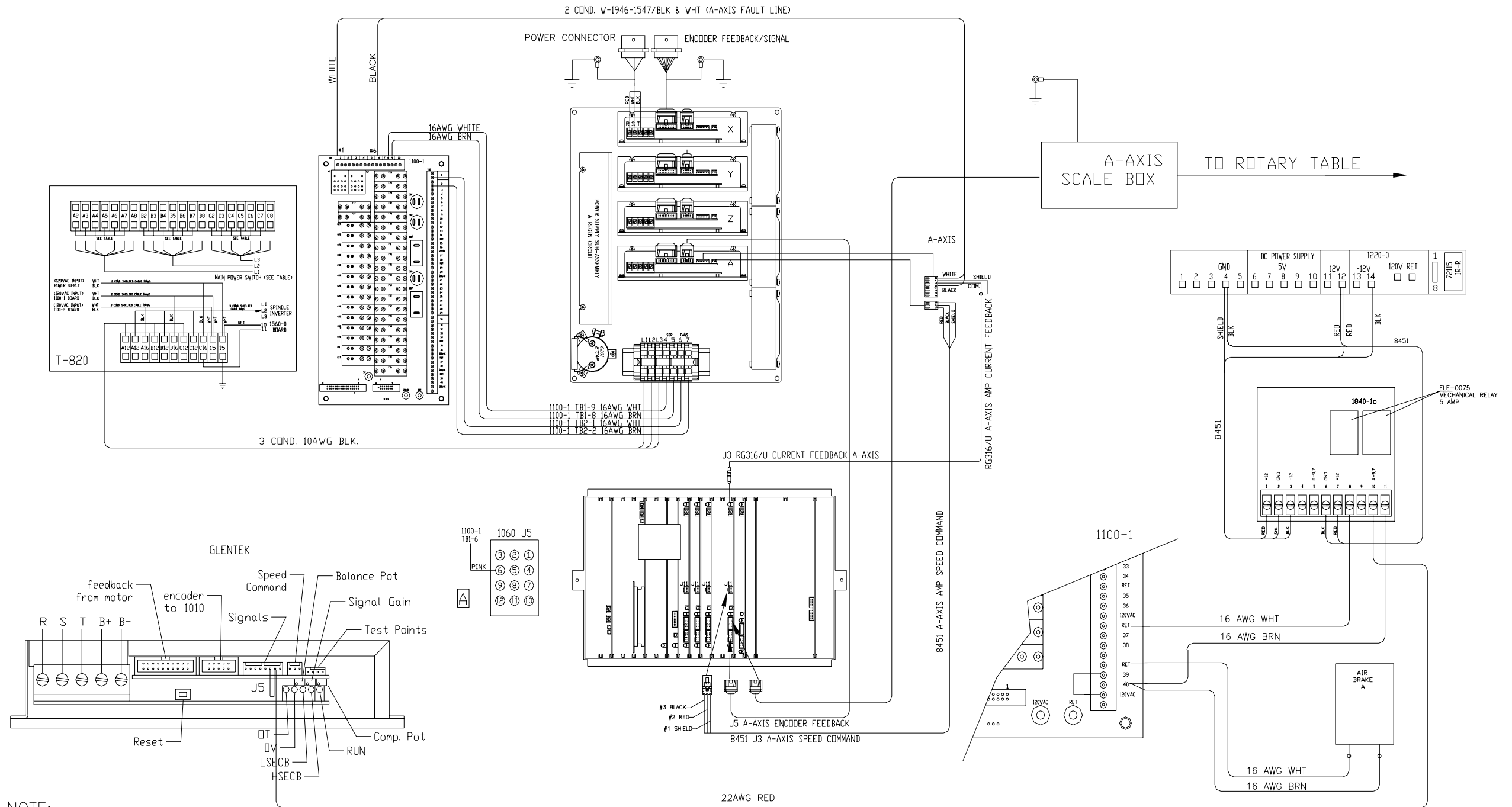

- NOTE:
1. INSTALL FUSE F11 (AGC 2) AND SOLID STATE RELAY K17 (GREEN) ON 1100-1 BOARD.
 2. USE GLENTEK AMPLIFIER AMP-0040 FOR V300 AND AMP-0029 FOR VH65.
 3. INSTALL JUMPER ON 4th AXIS AMPLIFIER IN J5 BETWEEN +LIMIT & -LIMIT (20 AWG RED).
 4. INSTALL FUSE 20A ONTO AXIS AMP. CHASSIS IN 4th AXIS FUSE HOLDER.
 5. FOR V300 ROTARY TABLE INSTALL SCALE BOX.

Wrg_0016B_ac_4th_5th_axis_for_ac_brushless_std_slant98

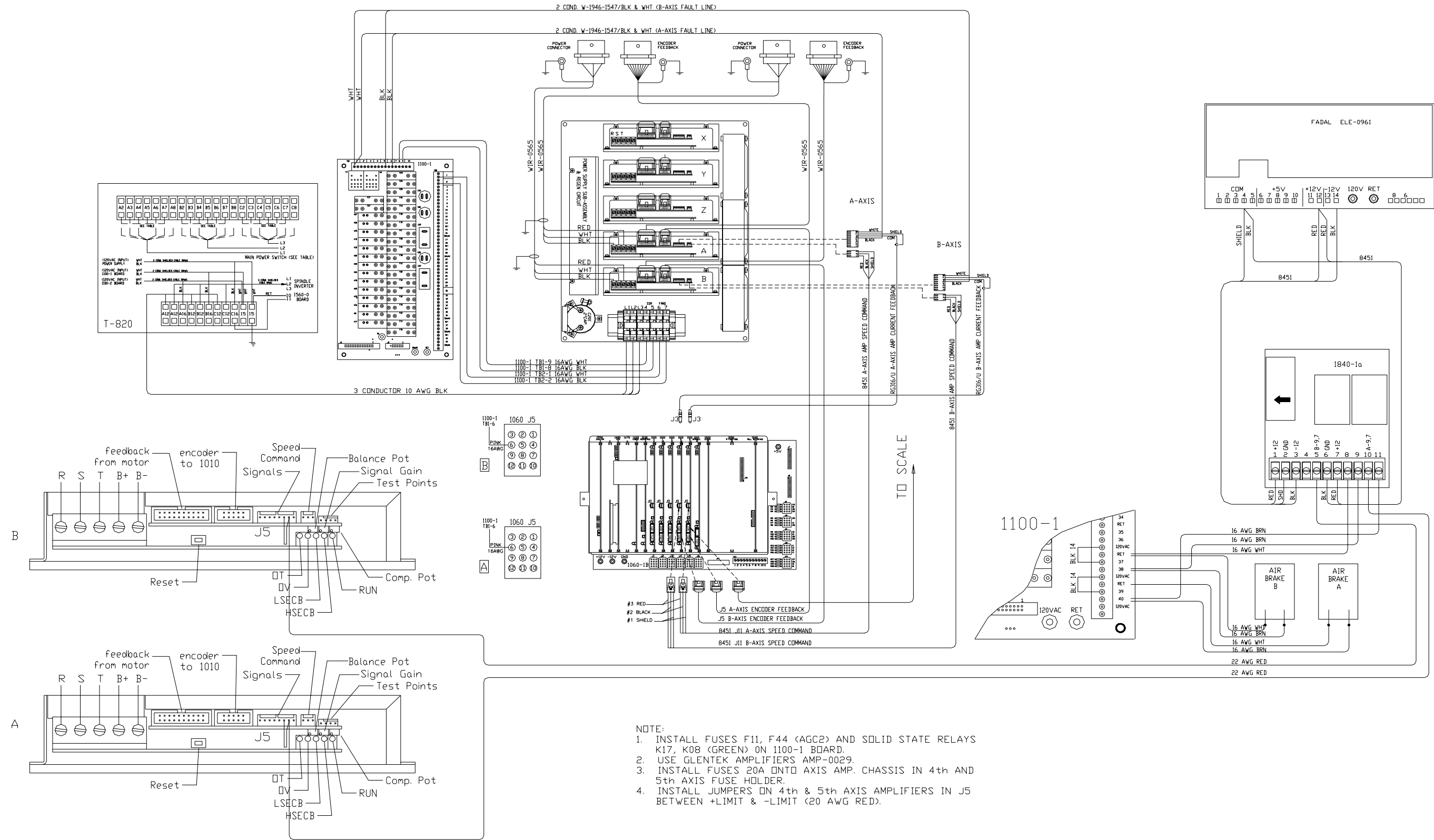

SERVO COOLANT WIRING DIAGRAM(4607-200)

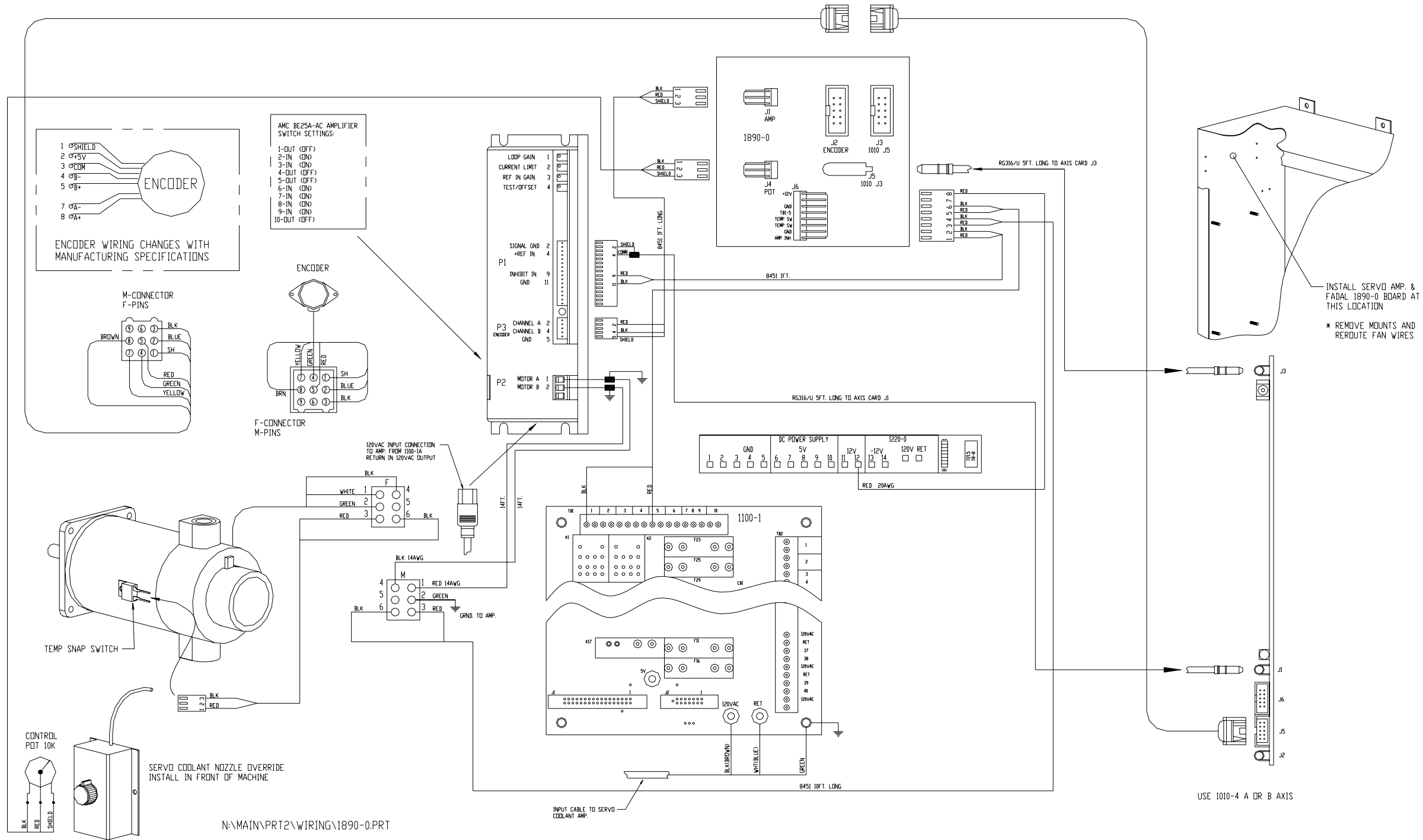

Wrg_0179A_servo_turret_wiring_diagram

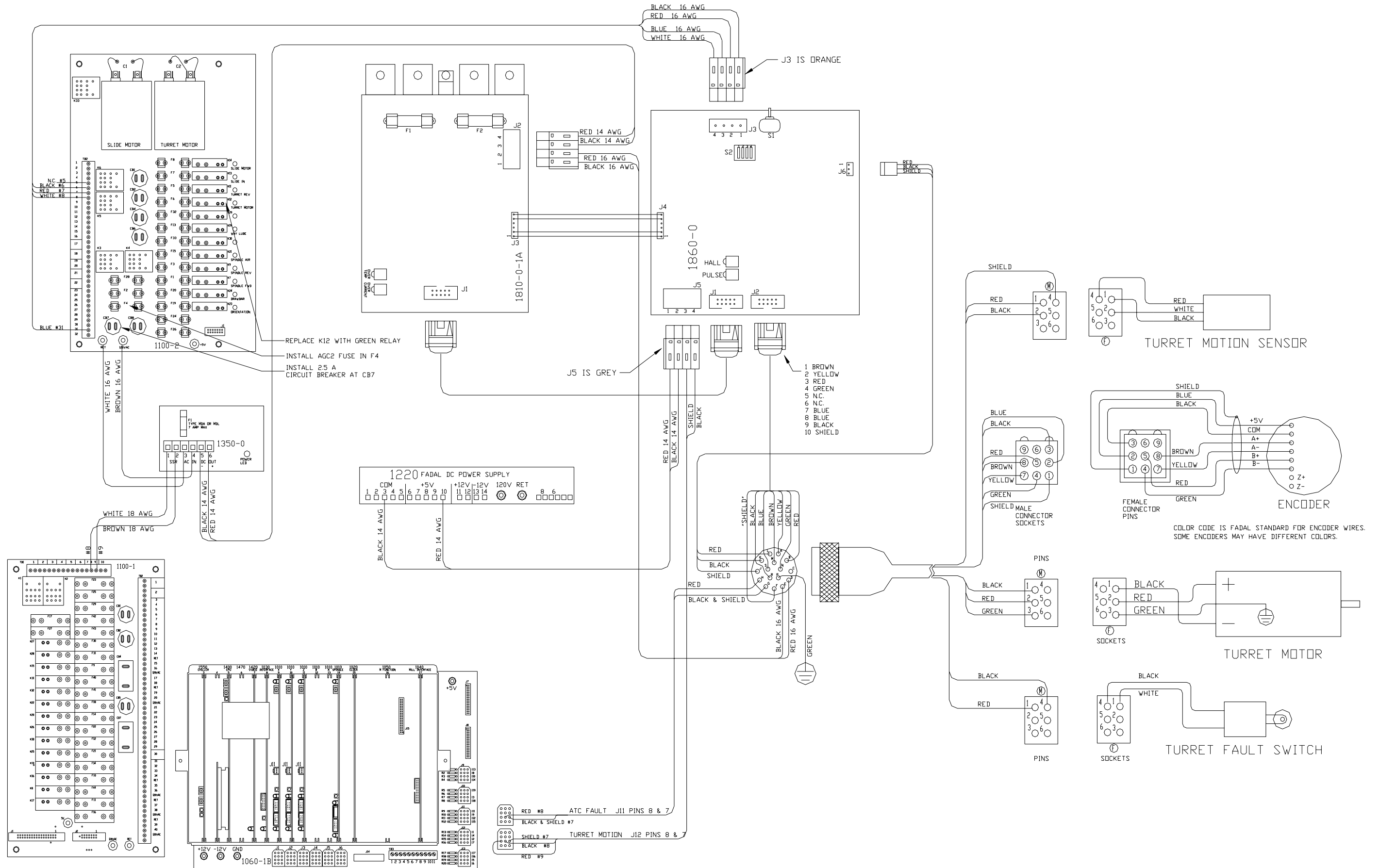

WRG_0179A_sht2of2_servo_turret_harness

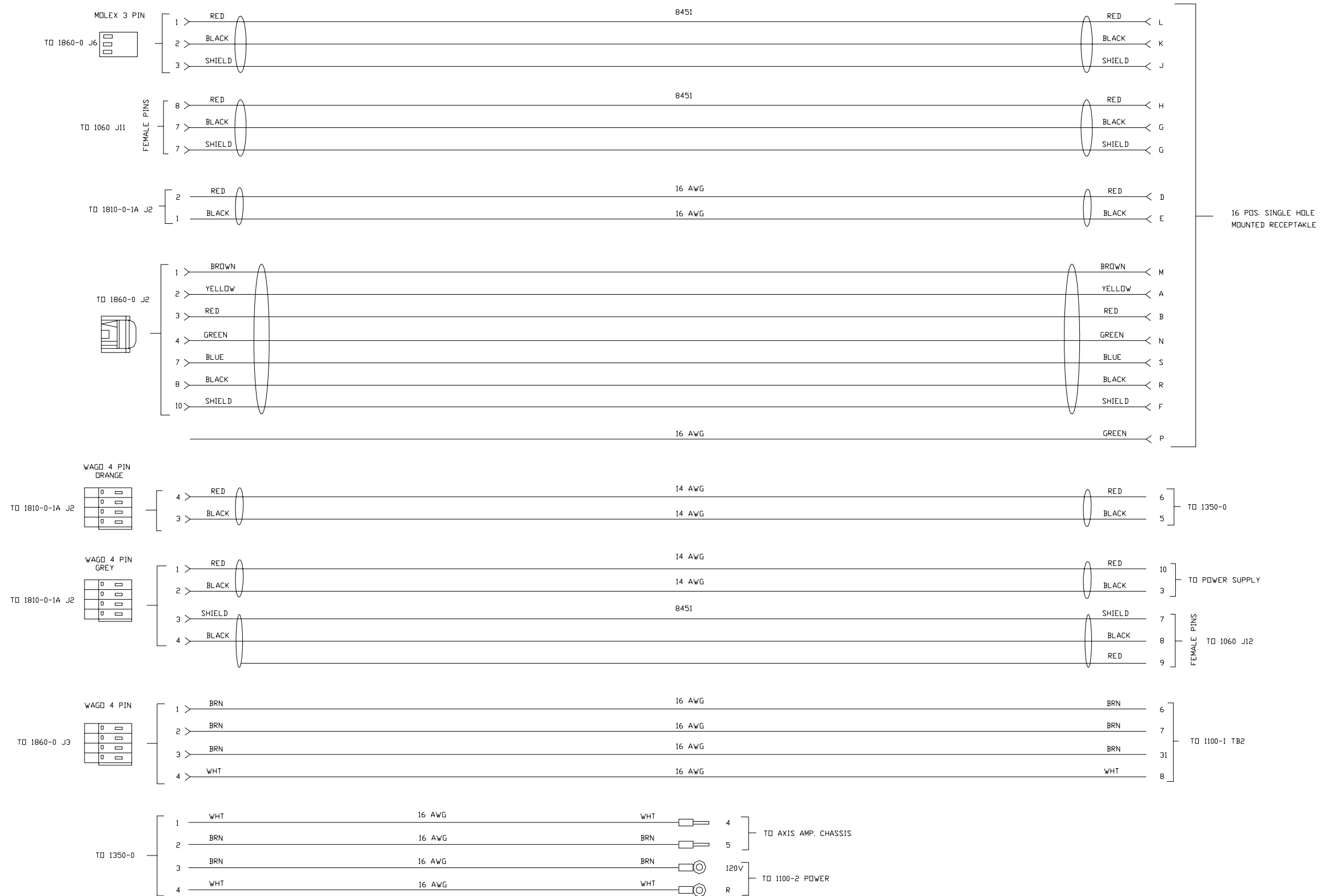

WRG_0671A_4th_axis_harness_for_ac_brushless

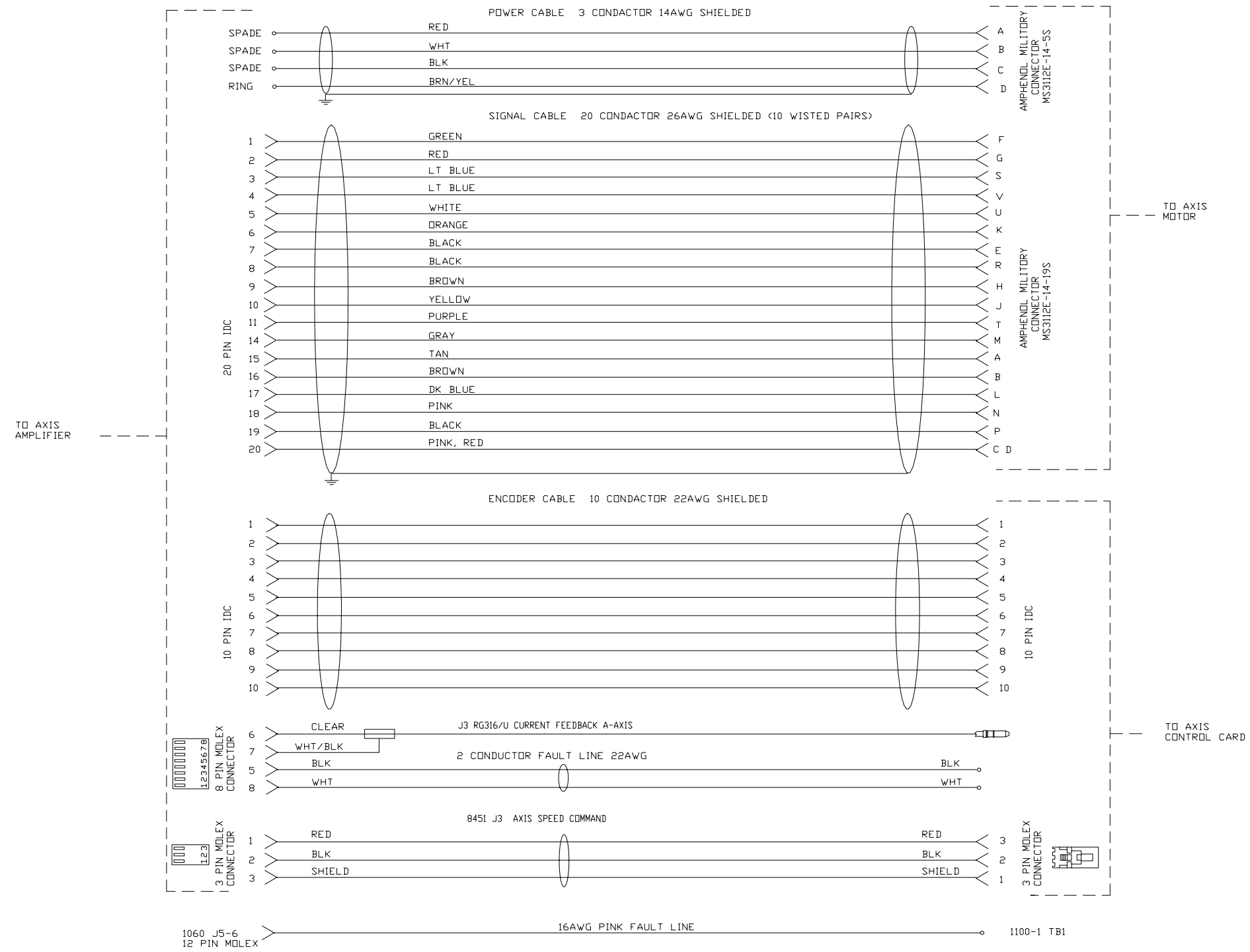

SECTION 4

Probes / Scales

RENISHAW TS-27 INTERFACE

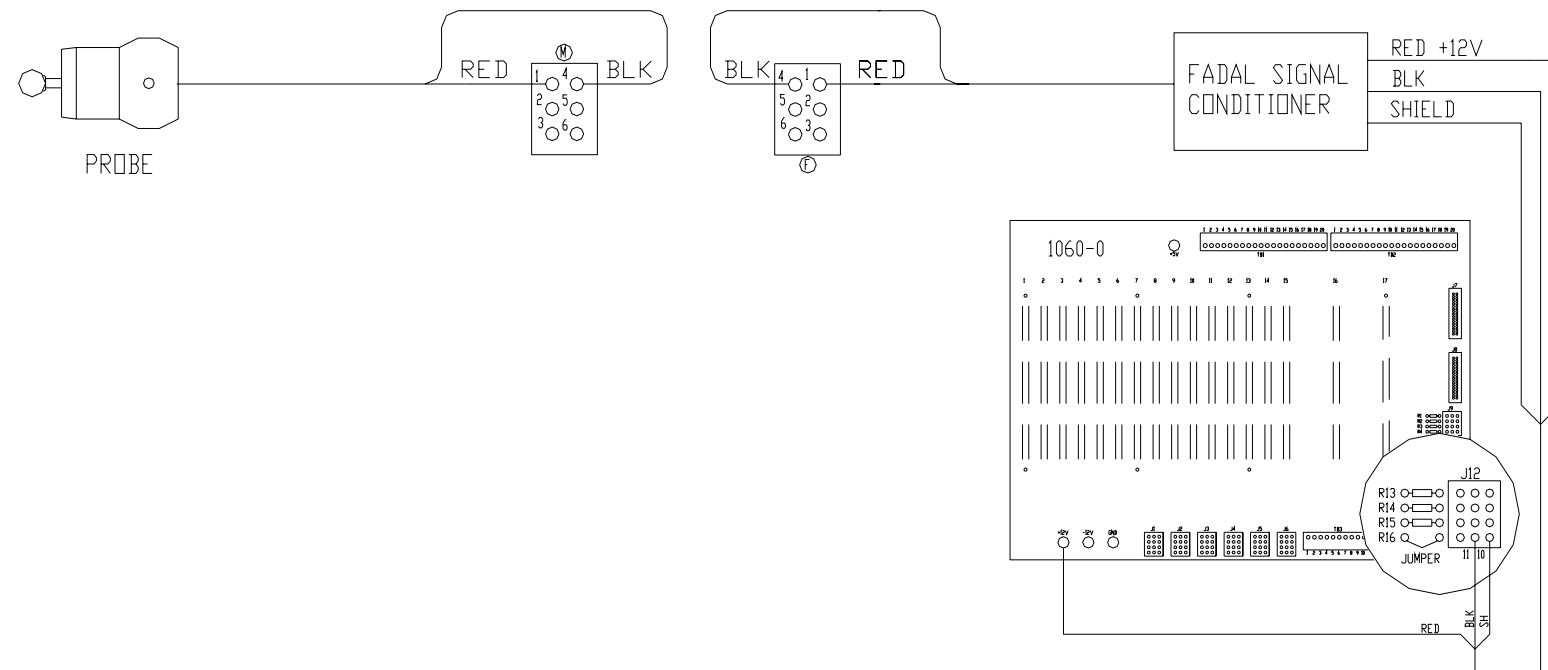
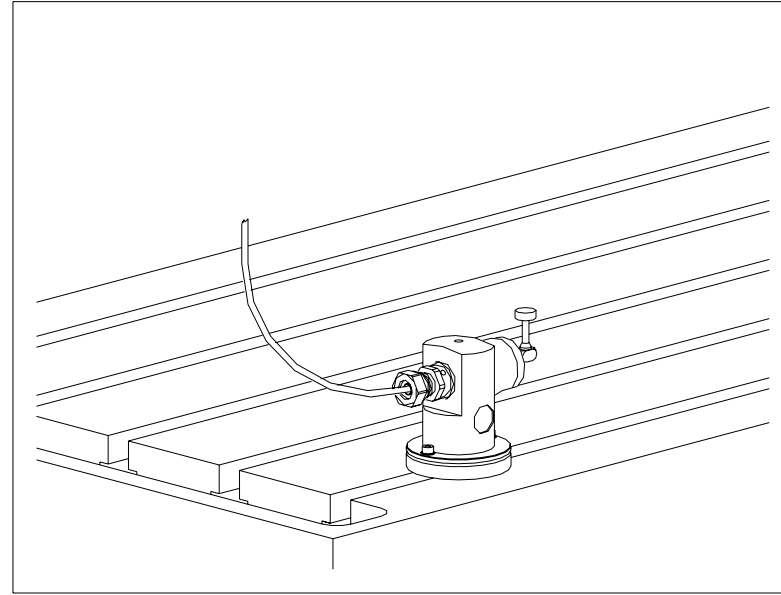

TOP RIGHT PANEL

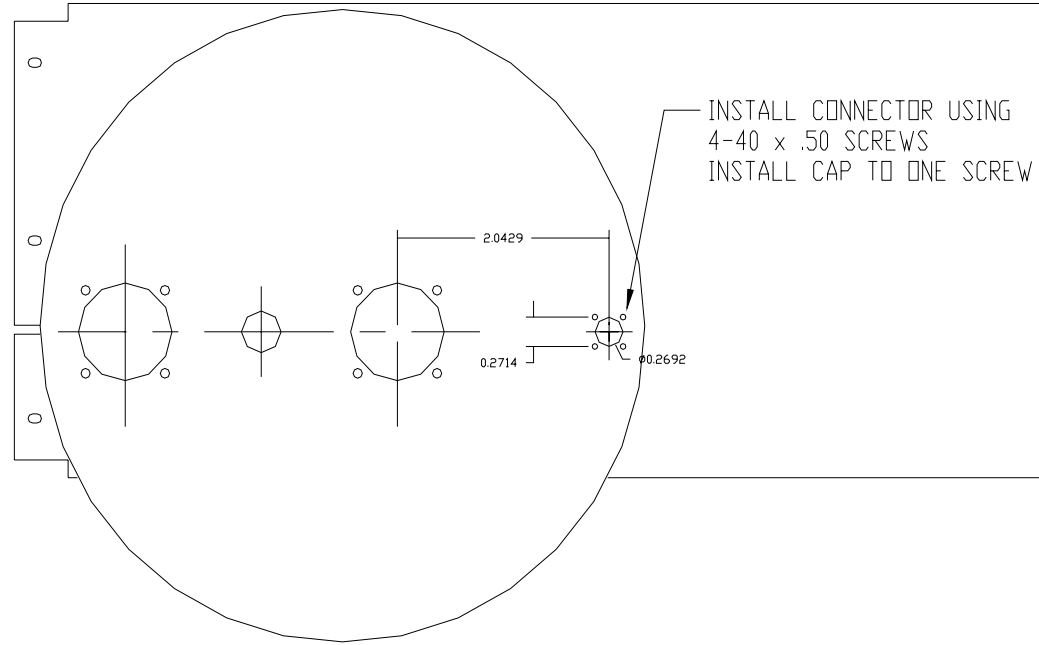

MP11 PROBE

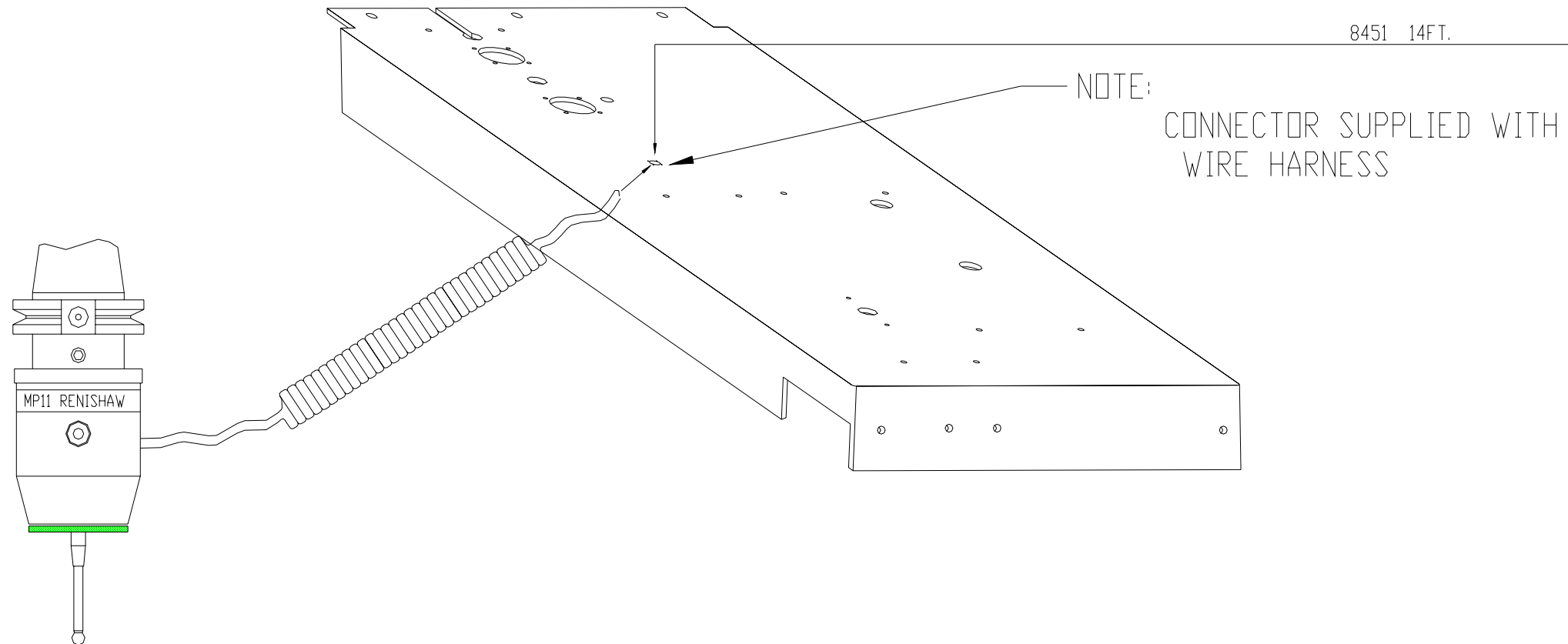
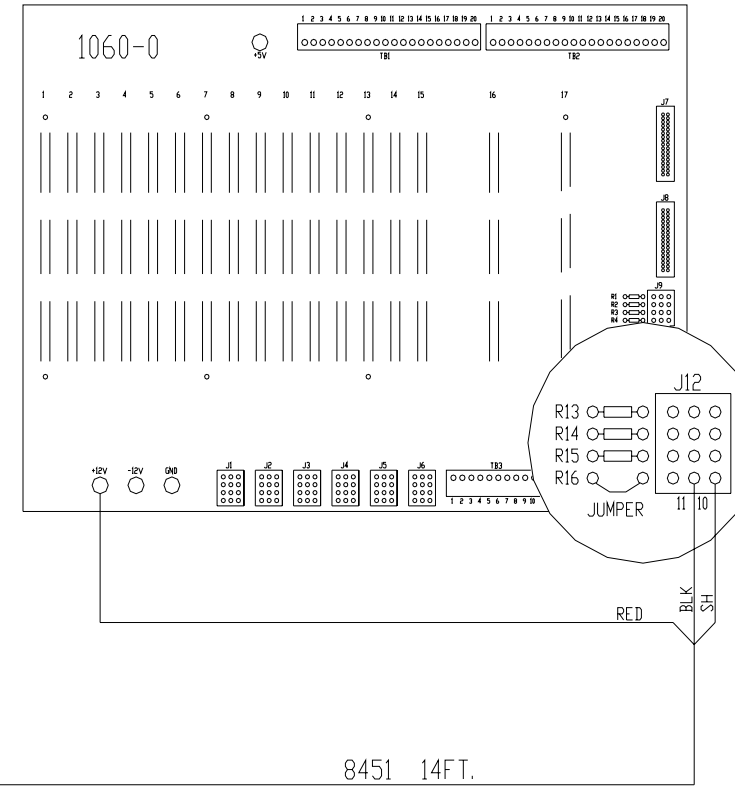

Wrg_0005_mp12_24v_power_supply

MP12 RENISHAW PROBE WITH FADAL 24V POWER SUPPLY

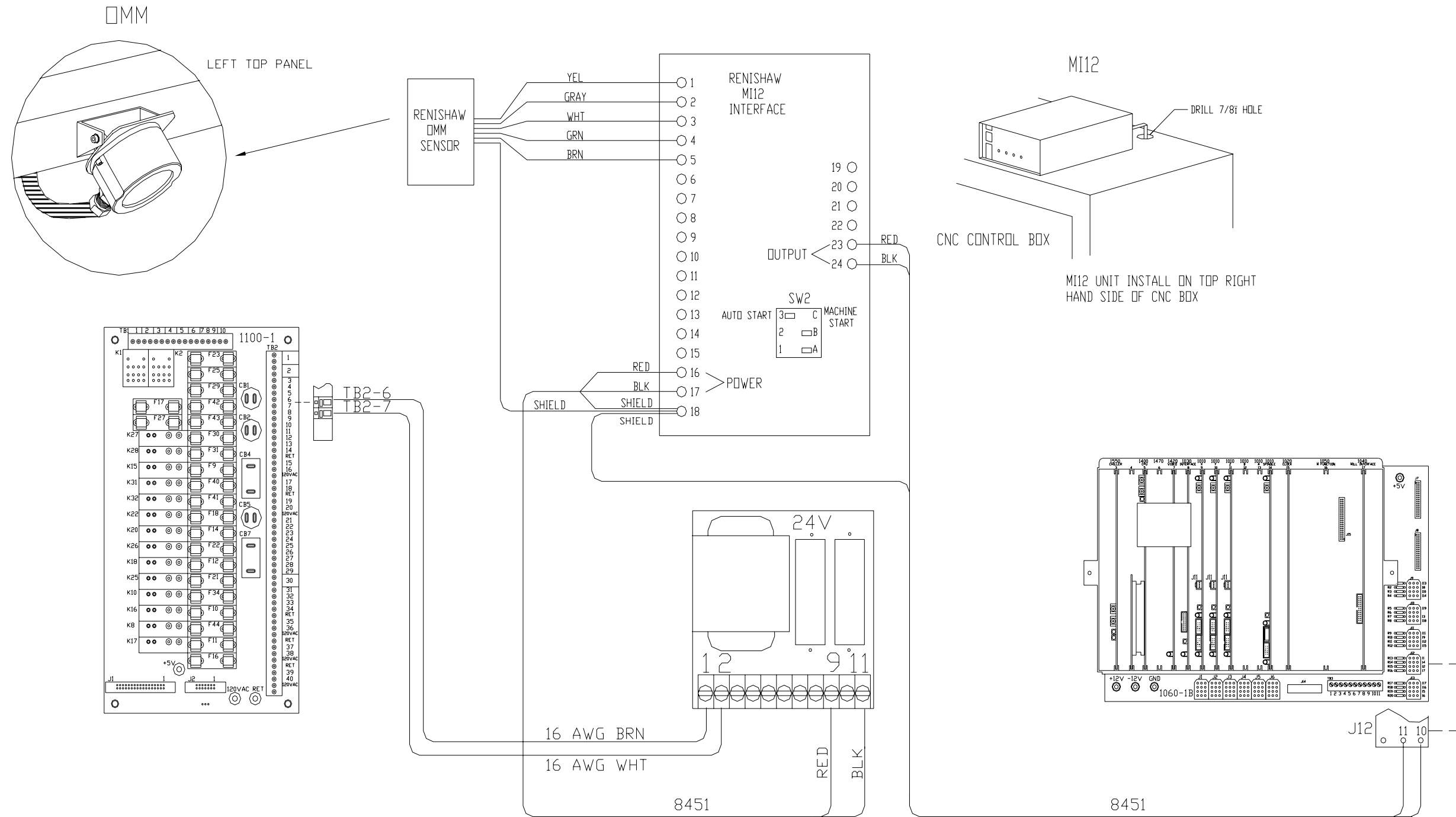

NOTE:

1. INSTALL FUSE F29 AGC 2 AND CIRCUIT BREAKER CB1 2.5A ON 1100-1 BOARD.
2. SET SWITCH SW2 (#3) IN MI12 INTERFACE UNIT TO THE AUTO START POSITION

MP11/TS27 PROBE WITH
FADAL 3 PROBE INTERFACE
BOARD 1570-1

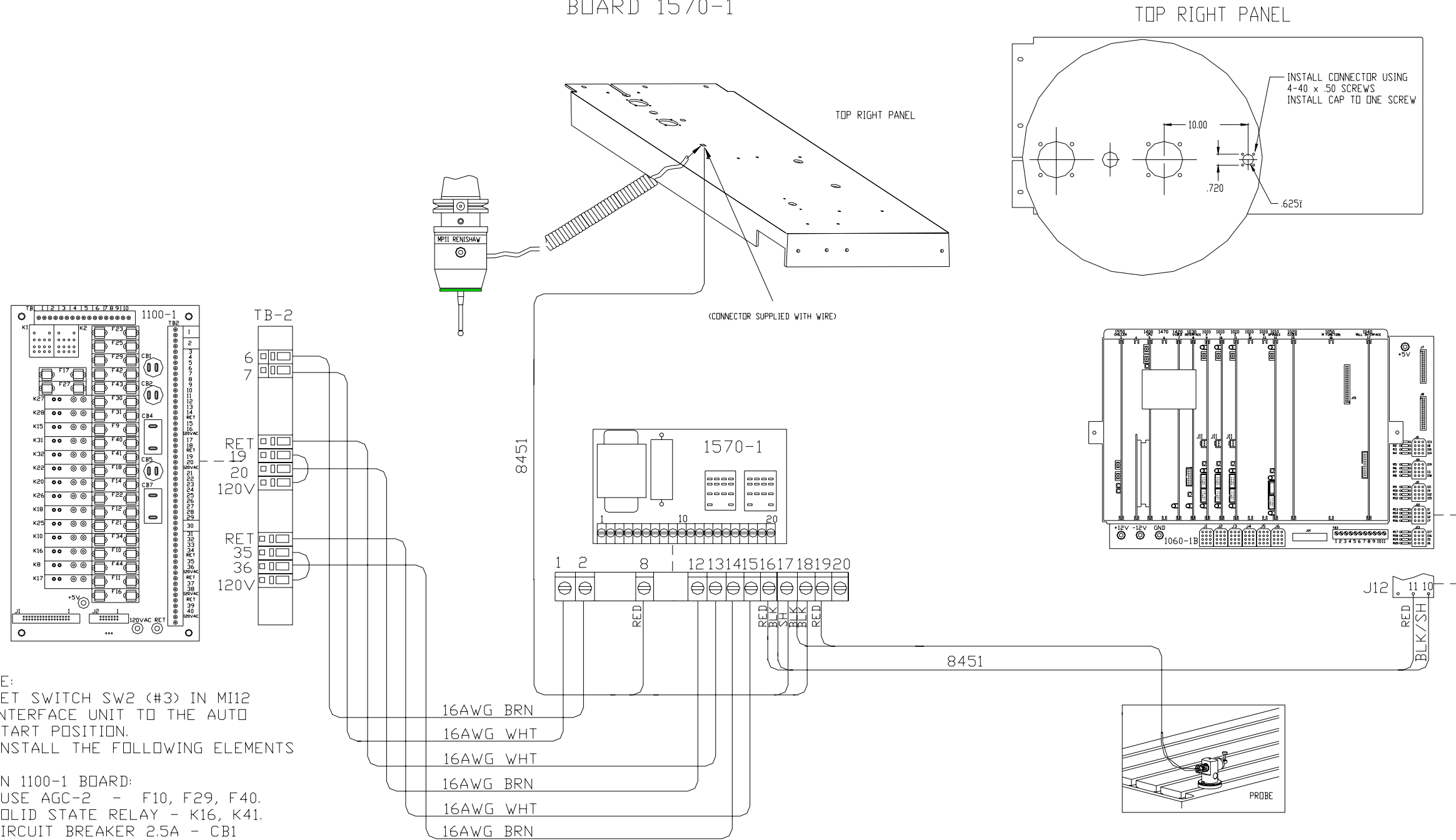

- NOTE:
1. SET SWITCH SW2 (#3) IN MI12 INTERFACE UNIT TO THE AUTO START POSITION.
 2. INSTALL THE FOLLOWING ELEMENTS

ON 1100-1 BOARD:
FUSE AGC-2 - F10, F29, F40.
SOLID STATE RELAY - K16, K41.
CIRCUIT BREAKER 2.5A - CB1
 3. TO ACTIVATE THE PROBES USE THE FOLLOWING COMMANDS:
MP12 PROBE - M64,M66
TS-27 - M65.

Wrg_0007B_mp12_ts27_with1570_1_board

MP12/TS27 PROBE WITH FADAL 3 PROBE INTERFACE BOARD 1570-1

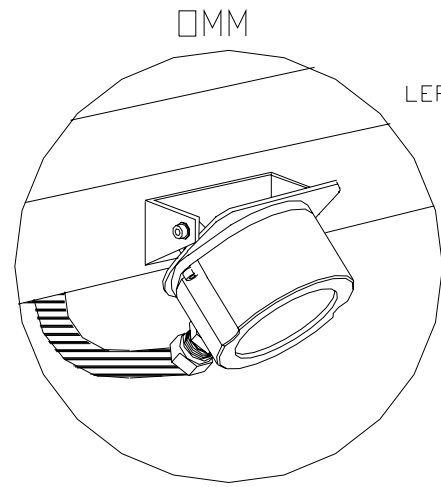

LEFT TOP PANEL

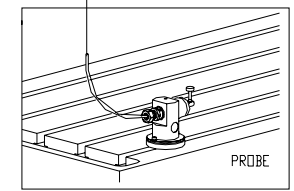
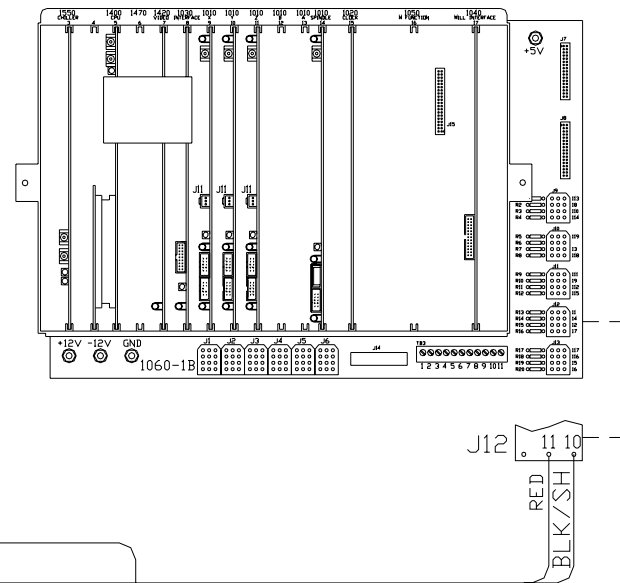
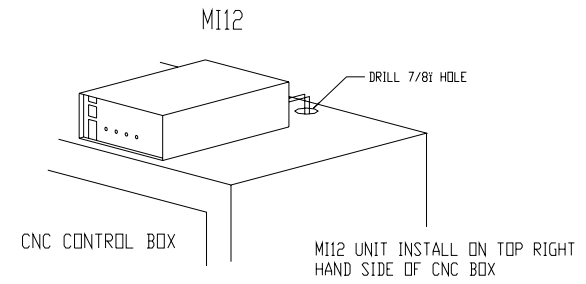
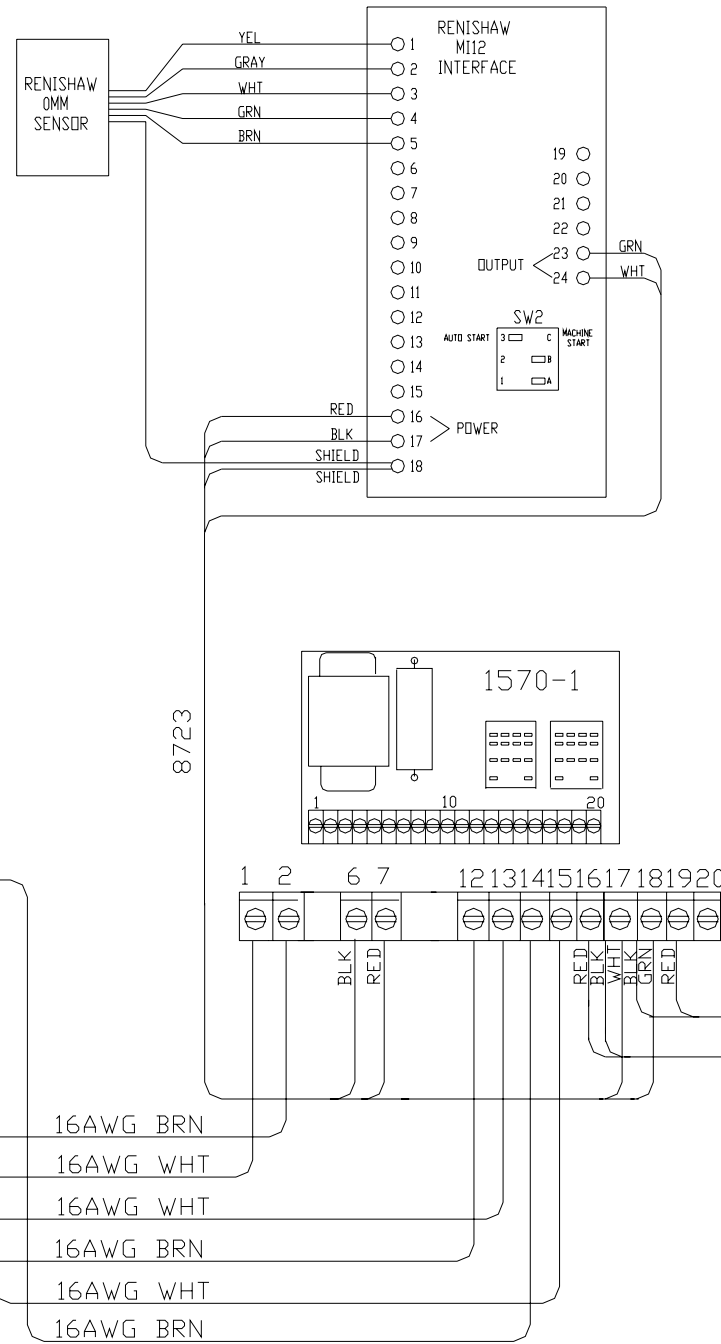
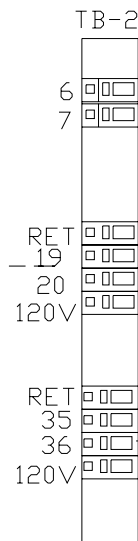
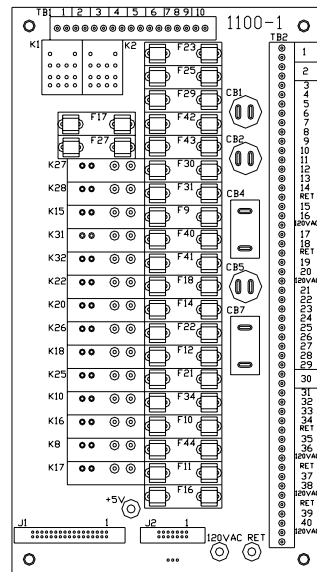

- NOTE:
- 1.SET SWITCH SW2 (#3) IN M112 INTERFACE UNIT TO THE AUTO START POSITION.
 - 2.INSTALL THE FOLLOWING ELEMENTS ON 1100-1 BOARD:
 FUSE AGC-2 - F10, F29, F40.
 SOLID STATE RELAY - K16, K41.
 CIRCUIT BREAKER 2.5A - CB1
 - 3.TO ACTIVATE THE PROBES USE THE FOLLOWING COMMANDS:
 MP12 PROBE - M64,M66
 TS-27 - M65.

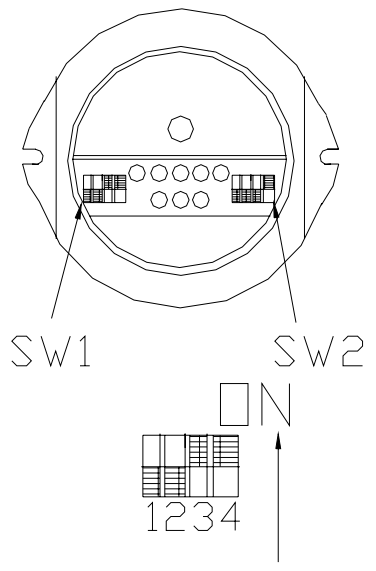
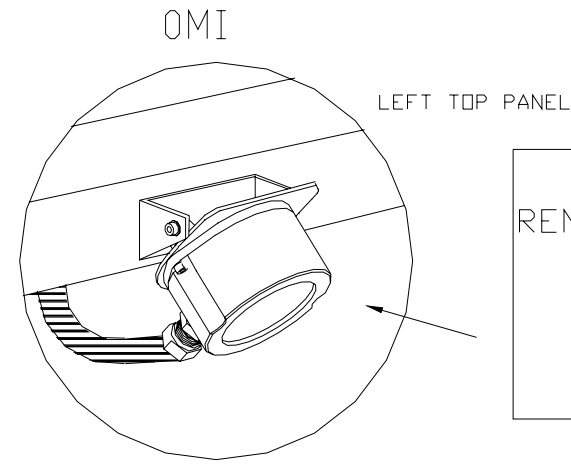

NOTE: SET SW1 TO AUTO START POSITION. - #4 TO GAIN ACCESS TO SW1 REMOVE OMI WINDOW AND LABEL.



24V POWER SUPPLY

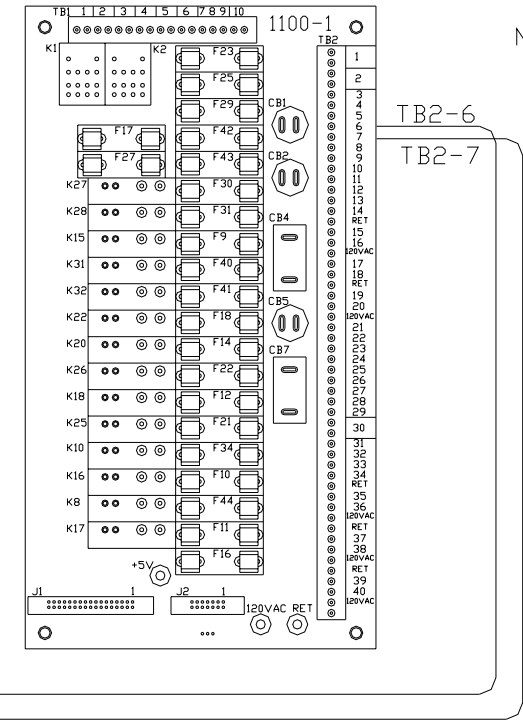
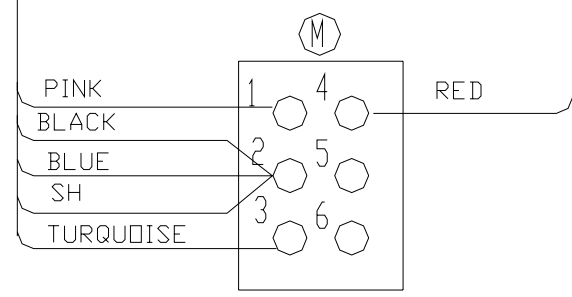
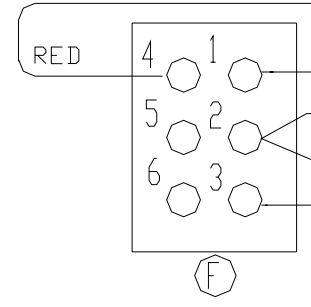
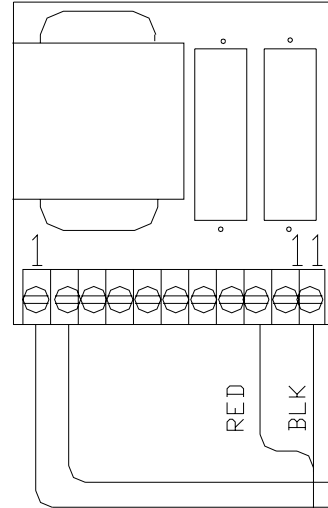

NOTE: INSTALL FUSE29AGC-2, CIRCUIT BREAKER

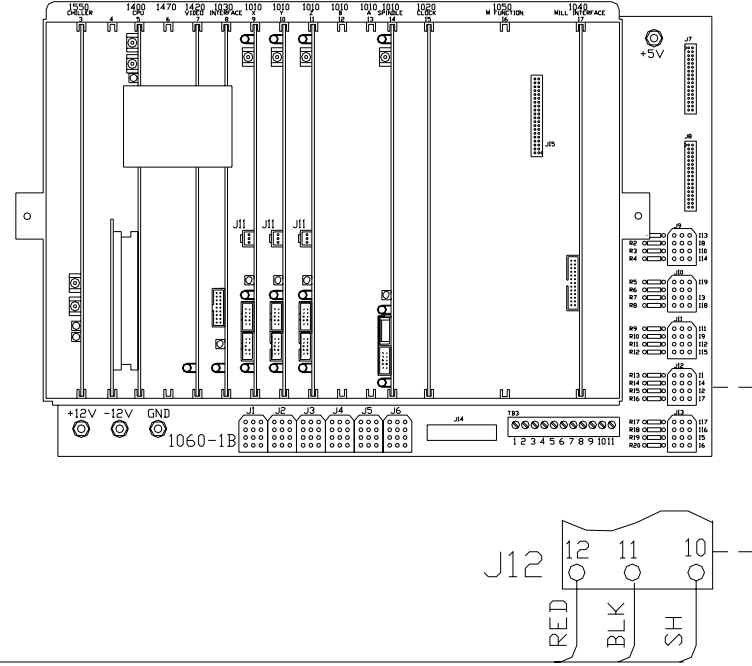

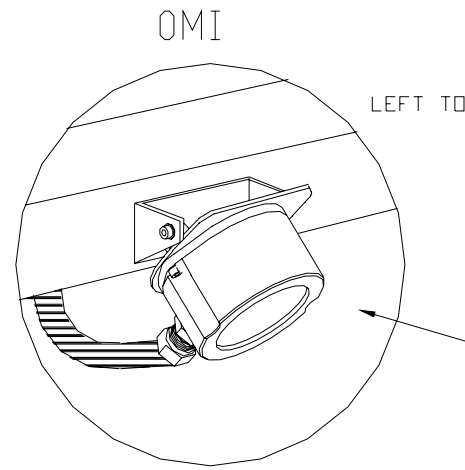

LEFT TOP PANEL

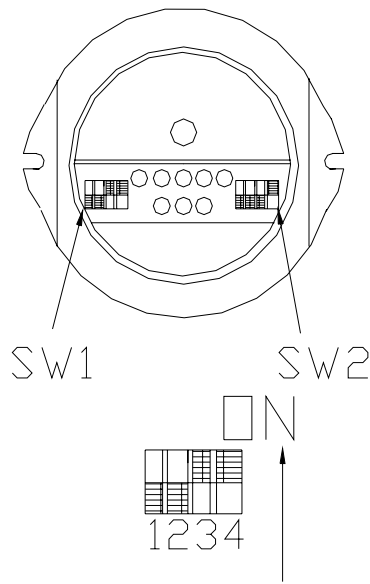
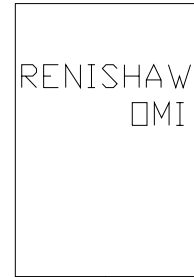

NOTE: 1.SET SW1 TO THE AUTO START POSITION - #4 ON.
 TO GAIN ACCESS TO SW1 REMOVE OMI WINDOW AND LABEL.
 2.INSTALL FOLLOWING ELEMENTS ON BOARD 1100-1
 FUSES AGC-2 - F10, F29, F40.
 SOLID STATE RELAYS (BLACK) - K16, K31.
 CIRCUIT BREAKER 2.5A - CB1
 3.TO ACTIVATE THE PROBES USE THE FOLLOWING COMMANDS:
 MP12 PROBE - M64, M66
 TS 27 PROBE - M65.

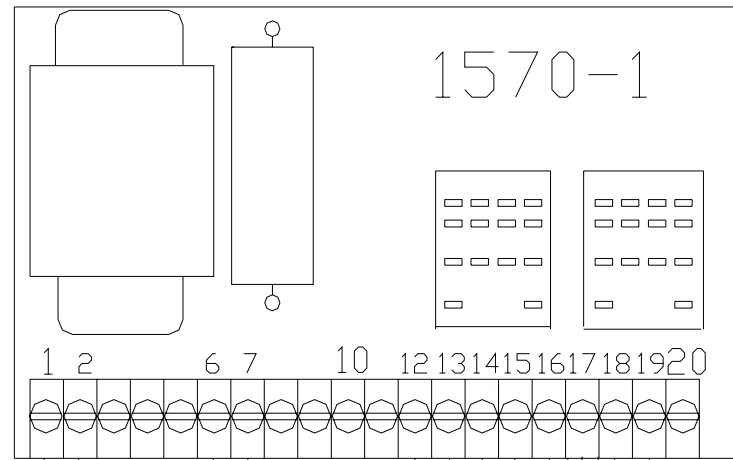

16AWG WHT
 16AWG BRN
 16AWG BRN
 16AWG WHT
 16AWG BRN
 16AWG WHT

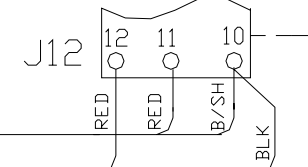
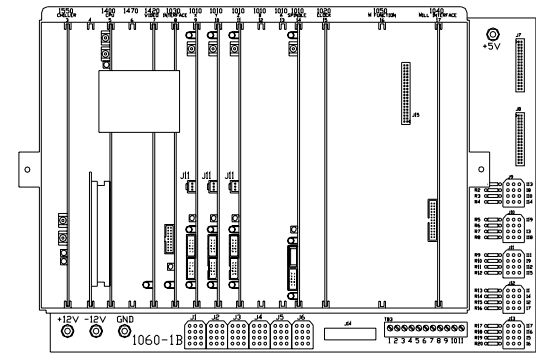
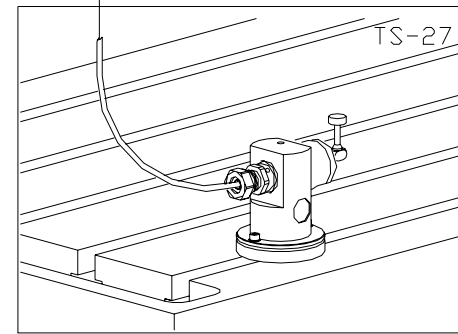
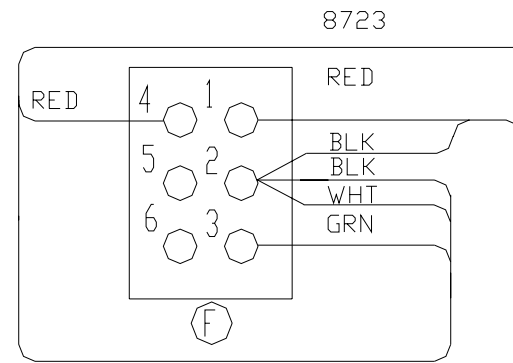
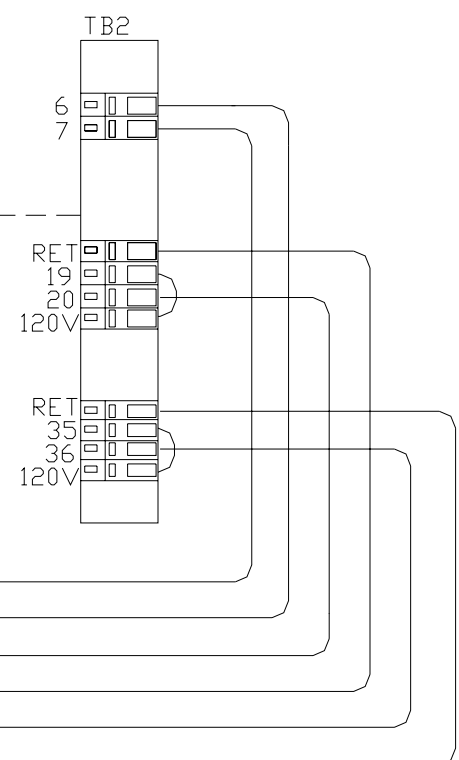
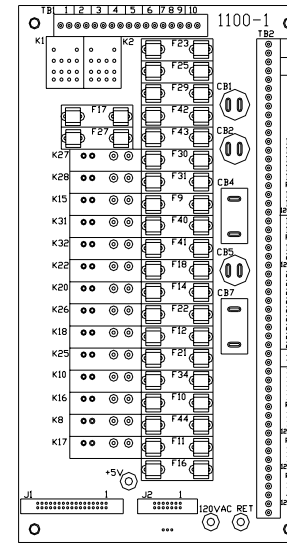

8451
 8451

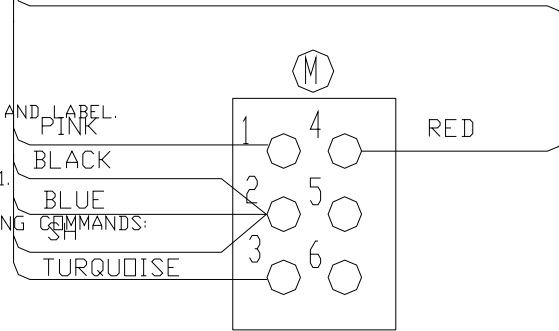

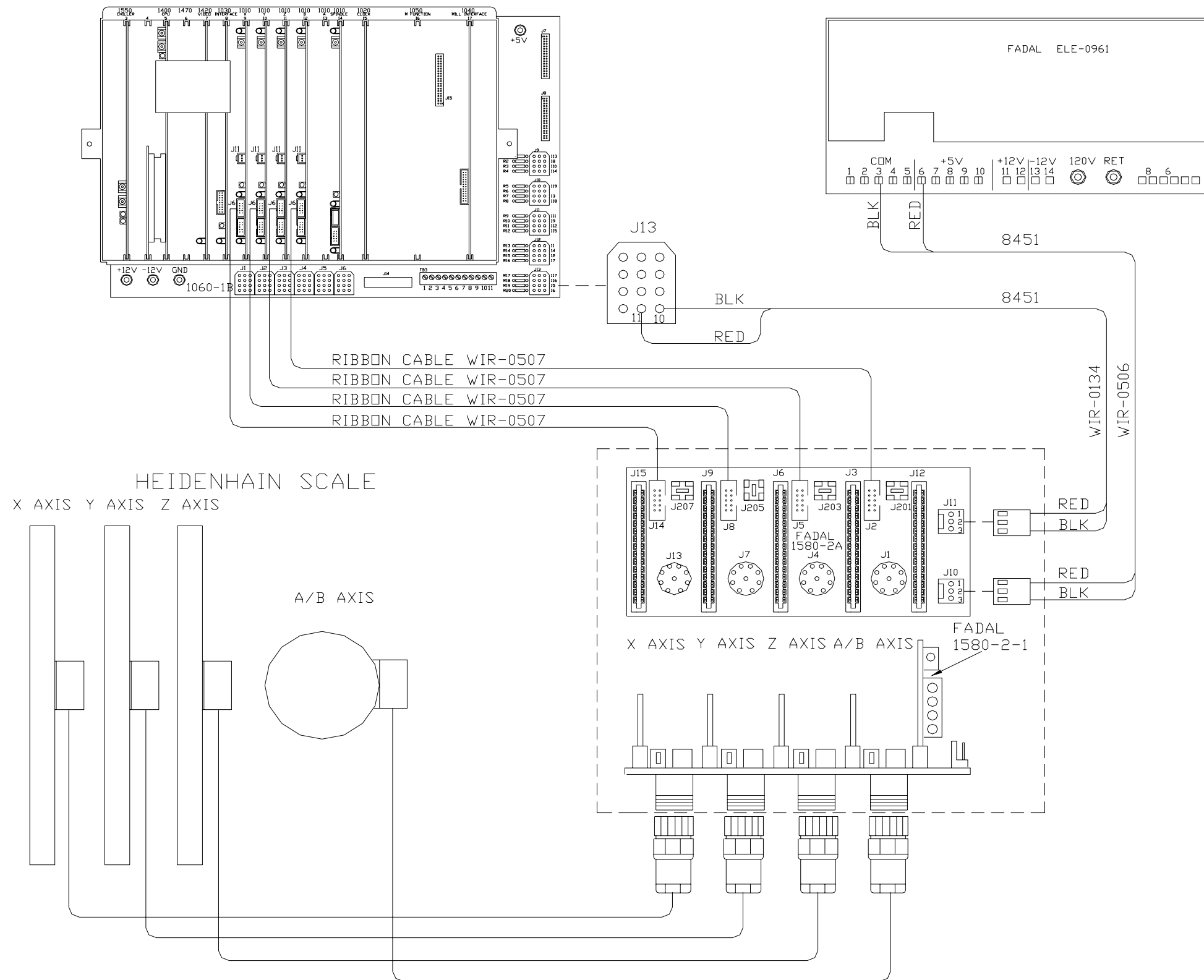

SECTION 5

Options

WRG_0011C_sht1of2_hydro_sweep_3valves

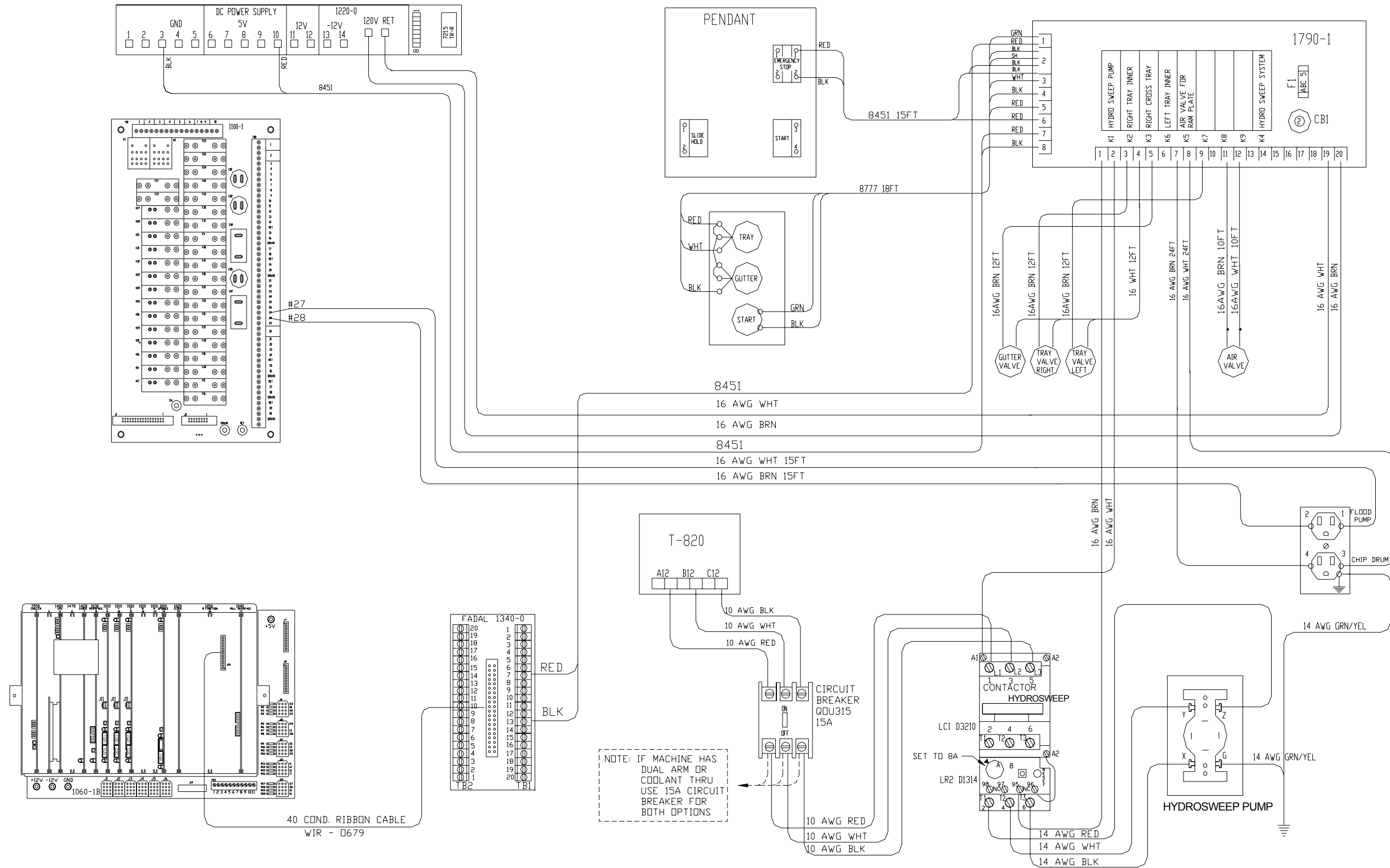

NOTE: IF MACHINE HAS DUAL ARM OR COOLANT THRU USE 15A CIRCUIT BREAKER FOR BOTH OPTIONS

NOTE: INSTALL EPROM VERSION 5.4 ON 1790-1 BOARD.

WRG_0011A_sht2of2_hydro_sweep_harness

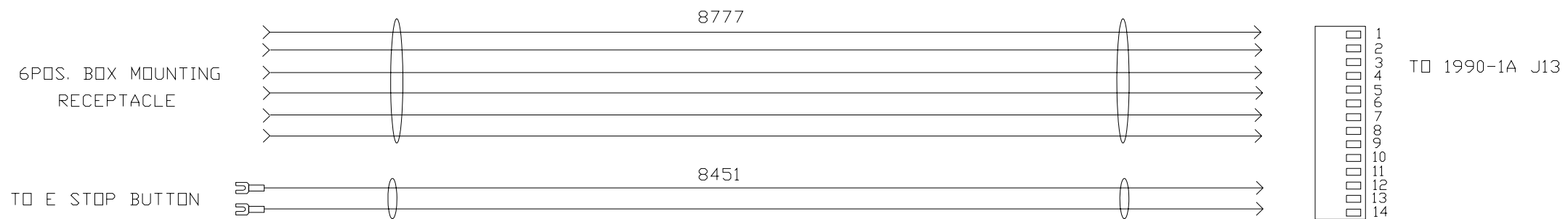
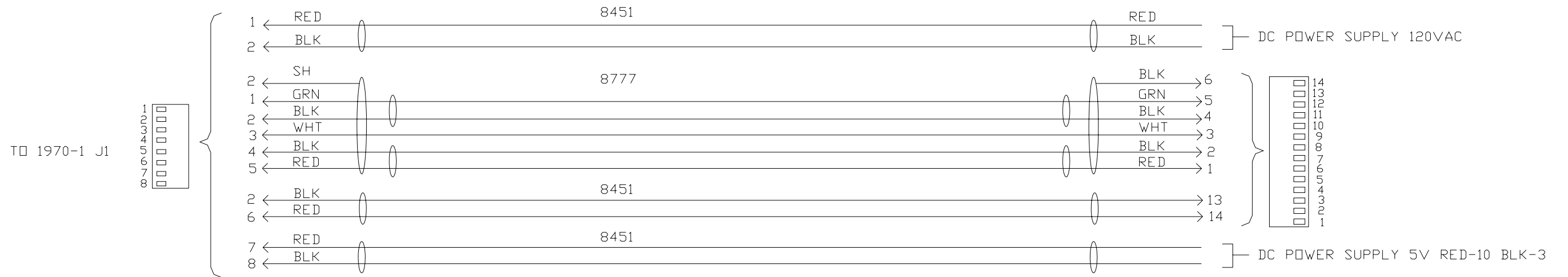
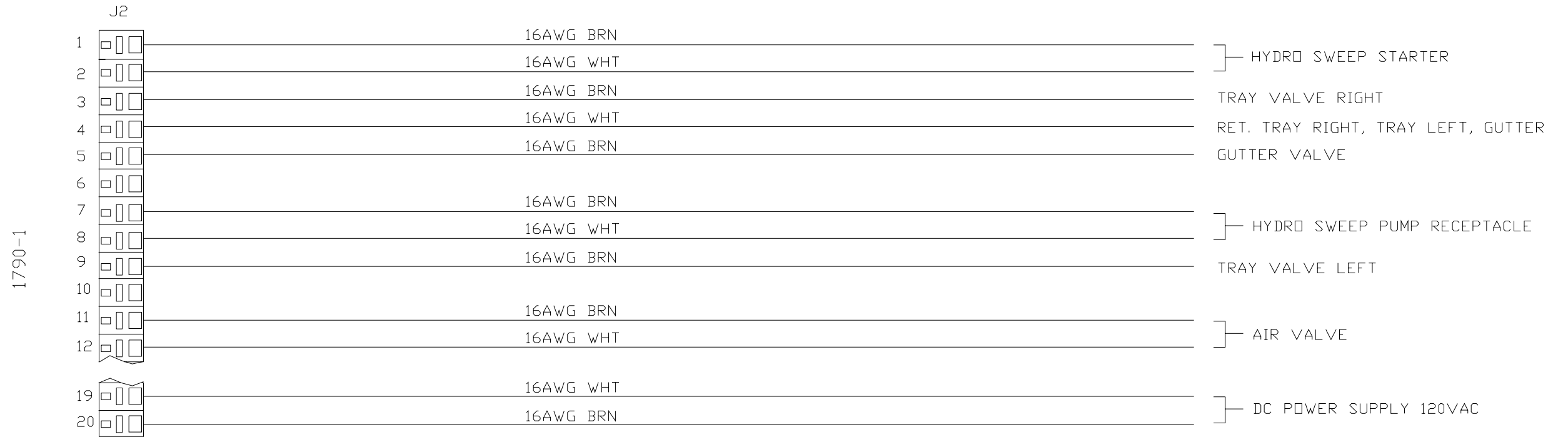

Wrg_0012C_hydro_sweep_6valves

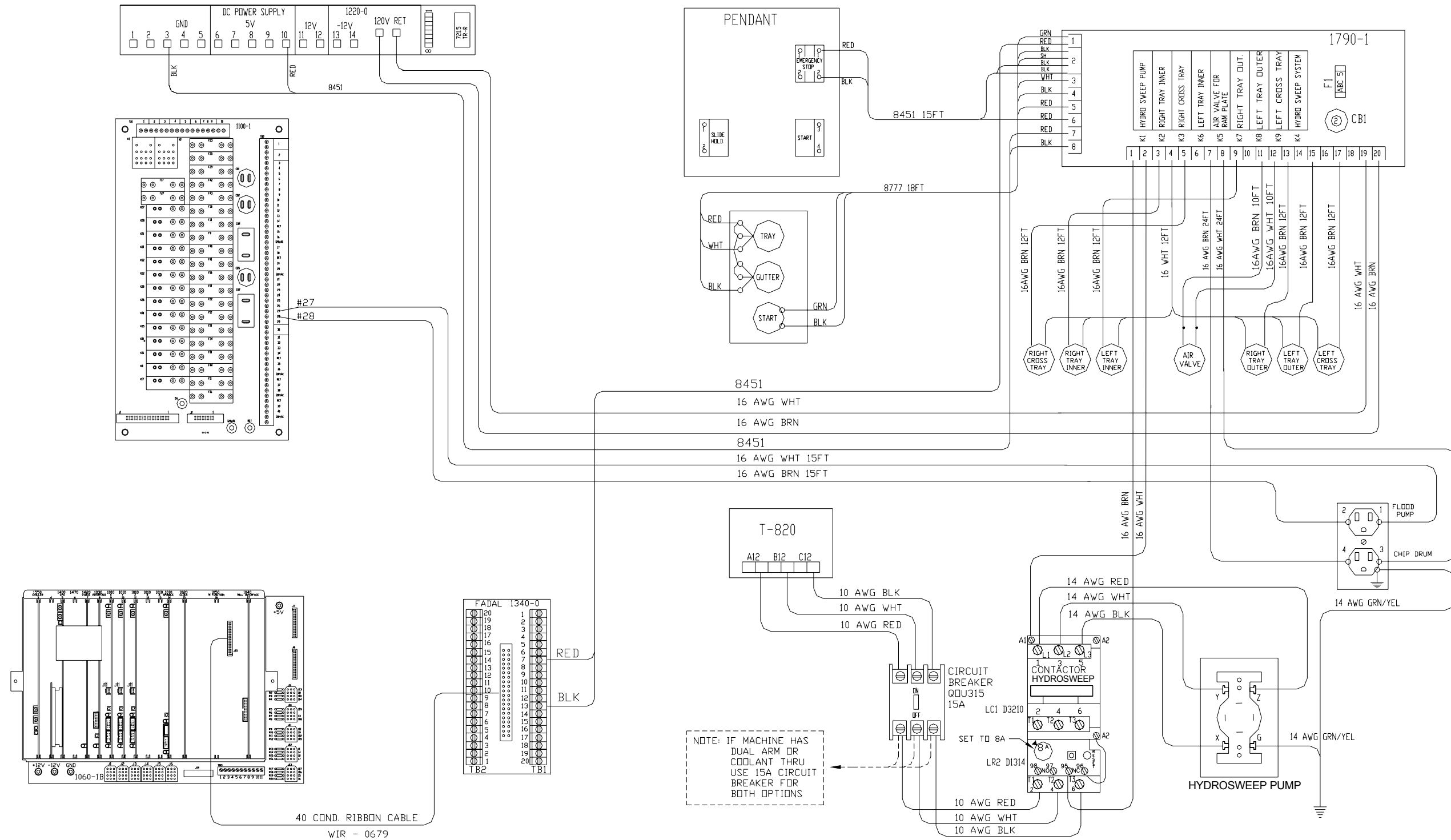

NOTE: INSTALL EPROM VERSION 6.4 ON 1790-1 BOARD.

Wrg_0013B_hydro_sweep_coolant_thru

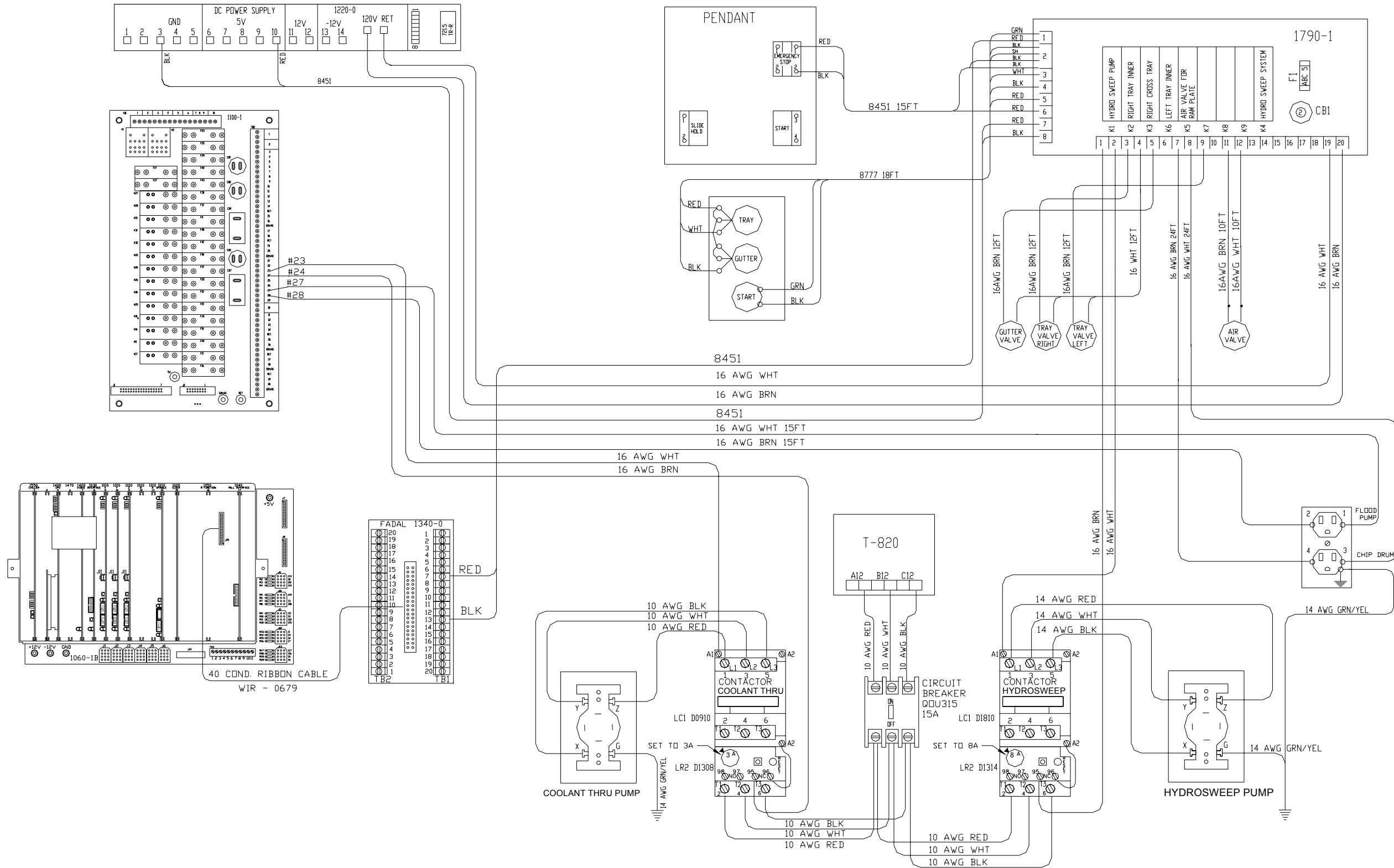

Wrg_0022A_hydro_sweep_1990_1a_board

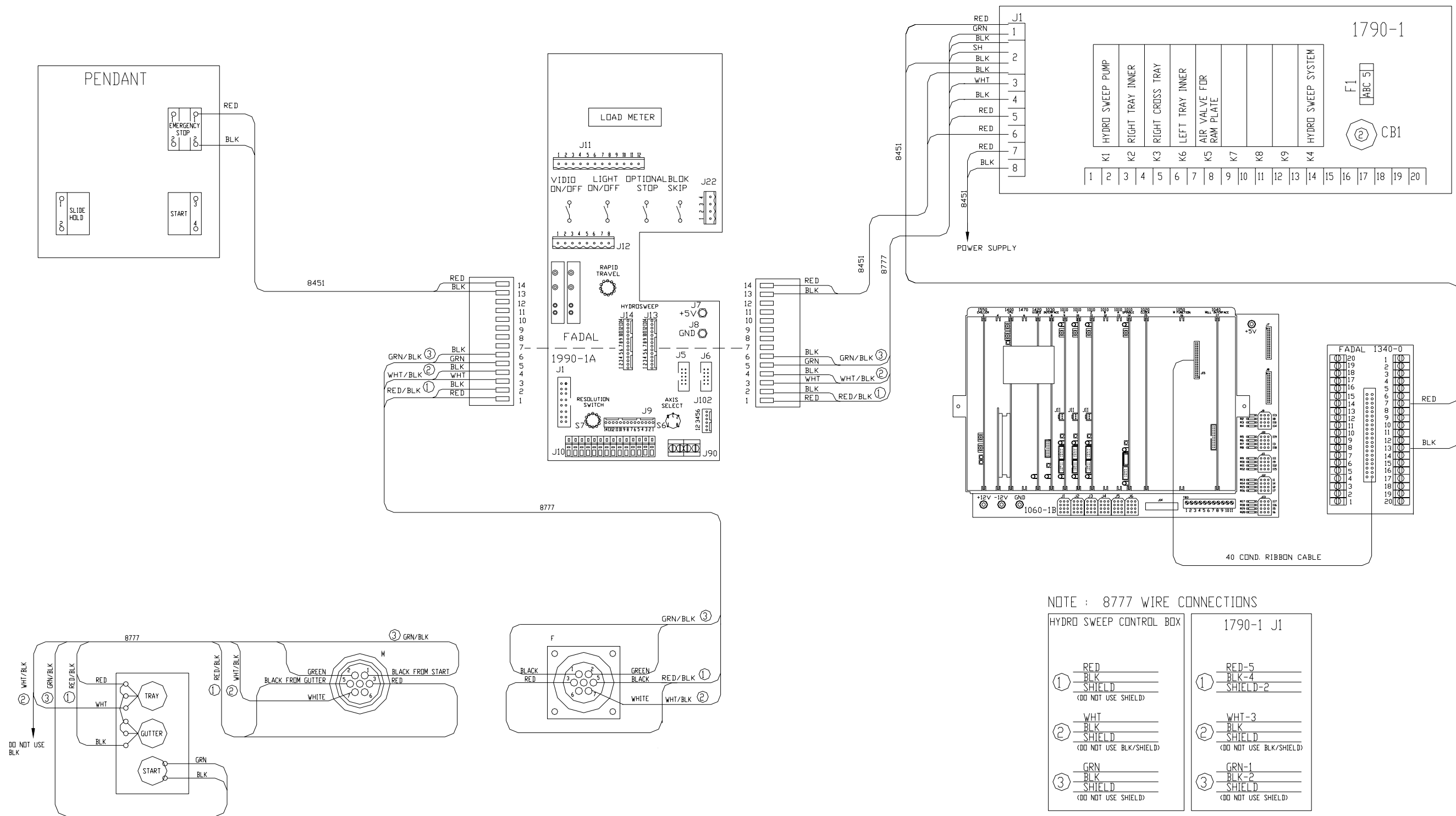

Wrg_0018B_pallet_changer_hydro_sweep

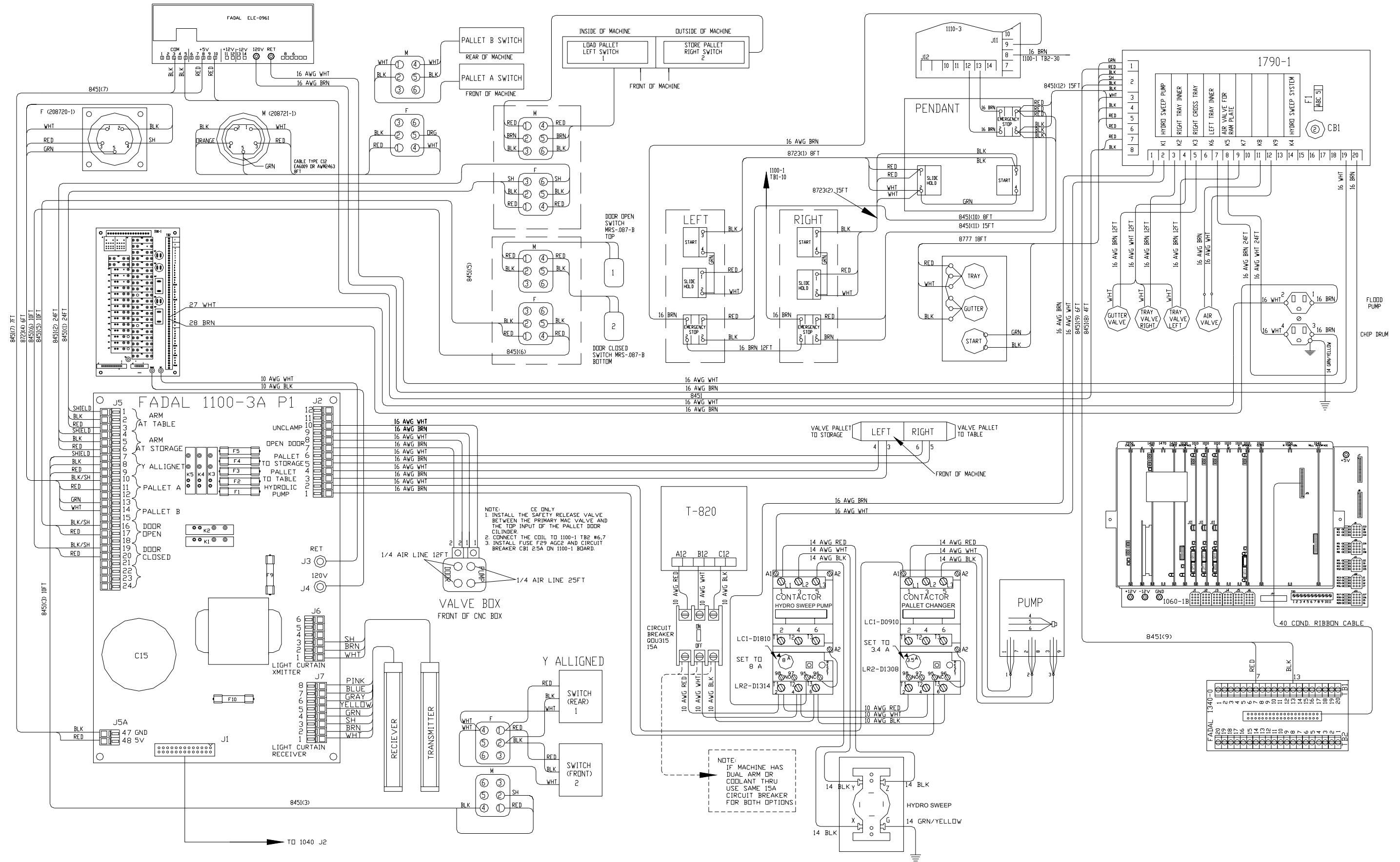

Wrg_0037F_auger_washdown_coolantthru

1310 PIN LIST

- J1**
 - 120 VAC (INPUT)
 - PUMP
 - VALVE #1
 - VALVE #2
 - VALVE #3
 - 120 RETURN (INPUT)
 - E-STOP (INPUT)
 - CONTACTOR FOR AUGER
 - CONTACTOR FOR SPINDLE
 - RETURN FOR SPINDLE CONTACTOR
 - RETURN FOR AUGER CONTACTOR AND PUMP STARTER
 - RETURN FOR VALVE COILS
- J2**
 - 1-3 AUGER MOTOR
 - 4-7 220 VAC
- J3**
 - START/STOP BUTTON
 - MODE SWITCH
 - M-FUNCTION INPUT
 - POT
 - +5V FOR POT
 - GROUND
 - EXTERNAL RESET
 - +5V
 - +5V (INPUT)
 - GROUND (INPUT)
 - EXTERNAL SLIDE HOLD OUTPUT
 - GROUND FOR EXTERNAL SLIDE HOLD
- J4**
 - LEFT DOOR SWITCH (BLK)
 - LEFT DOOR SWITCH (WHT)
 - LEFT DOOR SWITCH (RED)
 - LEFT DOOR SWITCH (GRN)
 - RIGHT DOOR SWITCH (BLK)
 - RIGHT DOOR SWITCH (WHT)
 - RIGHT DOOR SWITCH (RED)
 - RIGHT DOOR SWITCH (GRN)
 - FRONT DOOR SWITCH (BLK)
 - FRONT DOOR SWITCH (WHT)
 - FRONT DOOR SWITCH (RED)
 - FRONT DOOR SWITCH (GRN)

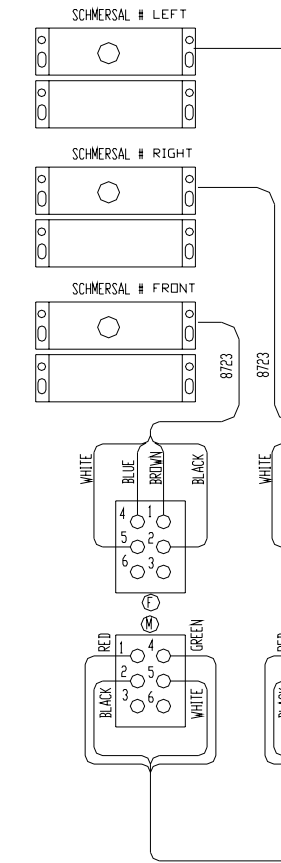

- K1 - SSR ELE-0070 TURN ON PUMP.
- K2 - SSR ELE-0070 VALVE 1.
- K3 - SSR ELE-0070 VALVE 2.
- K4 - SSR ELE-0070 VALVE 3.
- K6 - SSR ELE-0070 3 POLE RELAY 240V.
- K101 - SSR ELE-0101 SPINDLE RELAY.

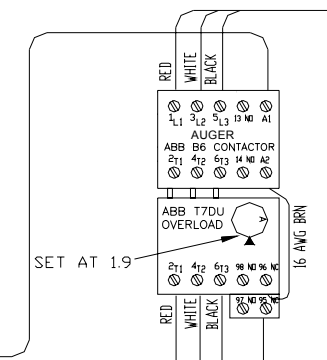
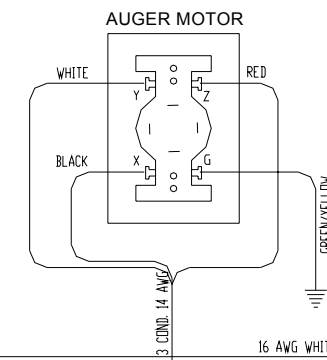
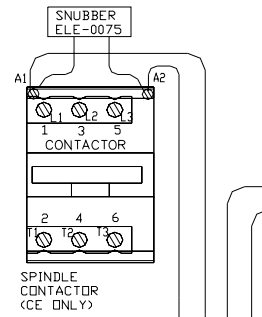

NOTE: IF MACHINE HAS ALSO HAS PALLET CHANGER AND DUAL ARM TOOL CHANGER THEN A SECOND 15A CIRCUIT BREAKER WILL BE REQUIRED. UL LIMIT FOR BRANCH MOTOR PROTECTION IS 15 A.

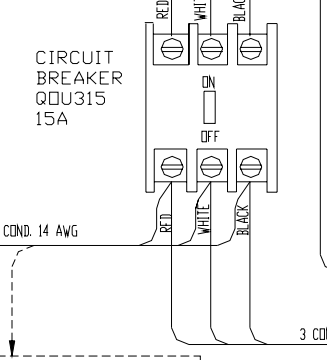

T-820 TRANSFORMER

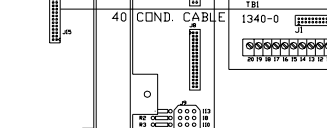
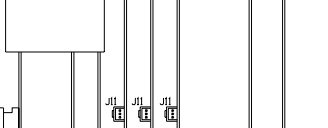
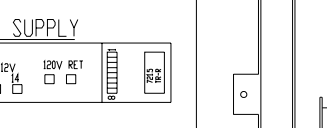
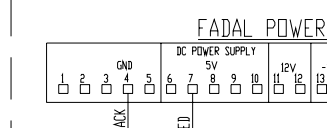
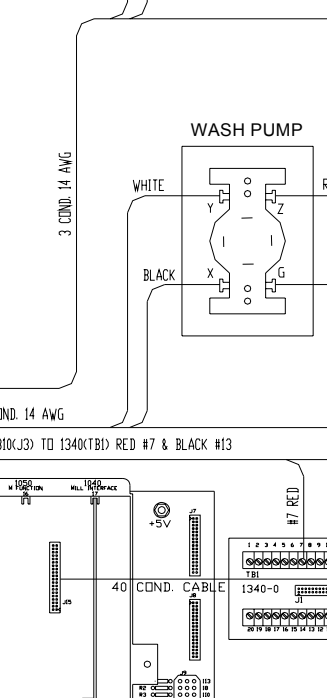
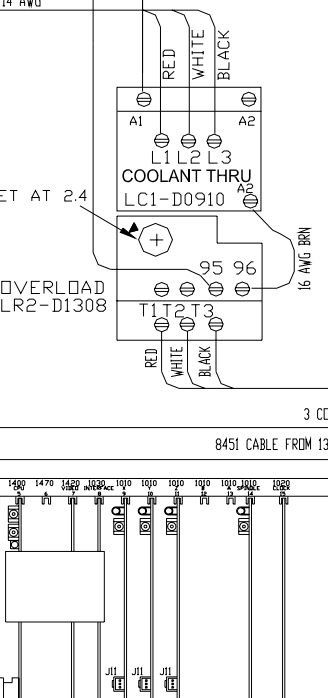
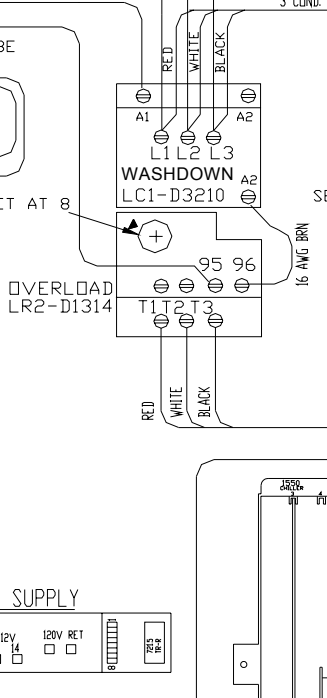
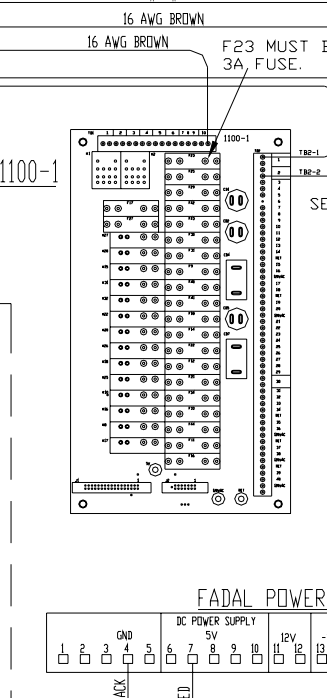
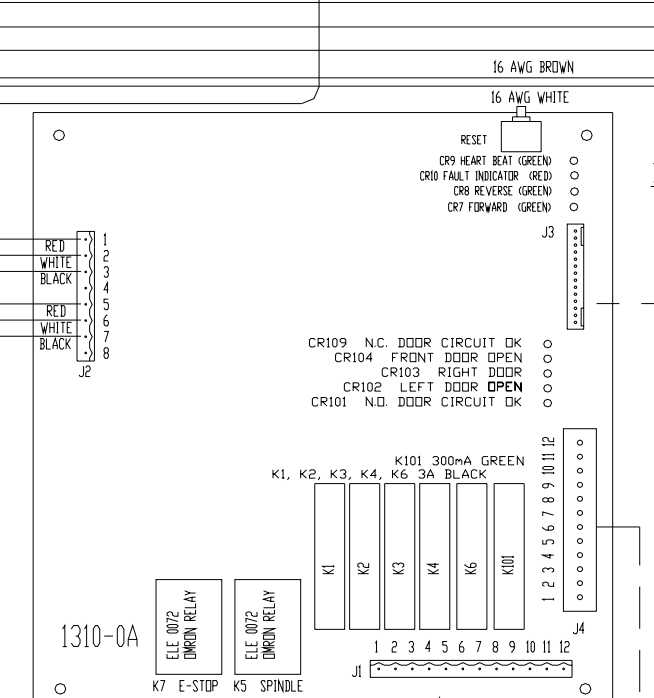
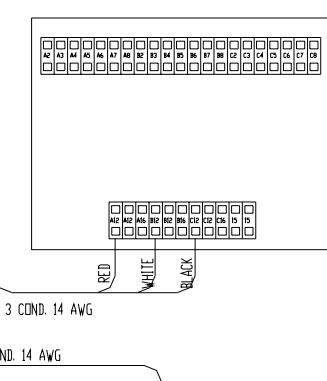

NOTE: REMOVE DOOR INTERLOCK FROM J13 PIN 8 & INSTALL AUGER INTERLOCK

START/STOP AUGER/WASH POT



Wrg_0693J_auger_washdown_wiring_diagram

1310 PIN LIST

- J1**
 - 120 VAC (INPUT)
 - PUMP
 - VALVE #1
 - VALVE #2
 - VALVE #3
 - 120 RETURN (INPUT)
 - E-STOP (INPUT)
 - CONTACTOR FOR AUGER
 - CONTACTOR FOR SPINDLE
 - RETURN FOR SPINDLE CONTACTOR
 - RETURN FOR AUGER CONTACTOR
 - AND PUMP STARTER
 - RETURN FOR VALVE COILS
- J2**
 - 1-3. AUGER MOTOR
 - 4-7. 220 VAC
- J3**
 - START/STOP BUTTON
 - MODE SWITCH
 - M-FUNCTION INPUT
 - POT
 - +5V FOR POT
 - GROUND
 - EXTERNAL RESET
 - +5V
 - +5V (INPUT)
 - GROUND (INPUT)
 - EXTERNAL SLIDE HOLD OUTPUT
 - GROUND FOR EXTERNAL SLIDE HOLD
- J4**
 - LEFT DOOR SWITCH (BLK)
 - LEFT DOOR SWITCH (WHT)
 - LEFT DOOR SWITCH (RED)
 - LEFT DOOR SWITCH (GRN)
 - RIGHT DOOR SWITCH (BLK)
 - RIGHT DOOR SWITCH (WHT)
 - RIGHT DOOR SWITCH (RED)
 - RIGHT DOOR SWITCH (GRN)
 - FRONT DOOR SWITCH (BLK)
 - FRONT DOOR SWITCH (WHT)
 - FRONT DOOR SWITCH (RED)
 - FRONT DOOR SWITCH (GRN)

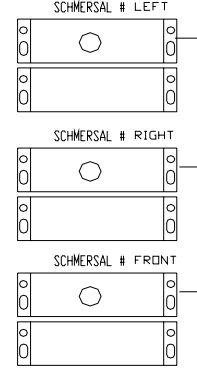

K1 - SSR ELE-0070 TURN ON PUMP.
 K2 - SSR ELE-0070 VALVE 1.
 K3 - SSR ELE-0070 VALVE 2.
 K4 - SSR ELE-0070 VALVE 3.
 K6 - SSR ELE-0070 3 POLE RELAY 240V.
 K101 - SSR ELE-0101 SPINDLE RELAY

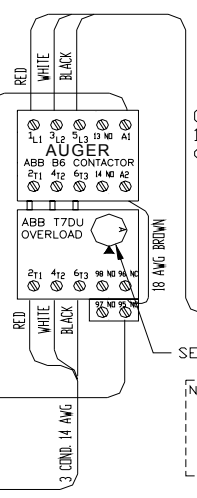
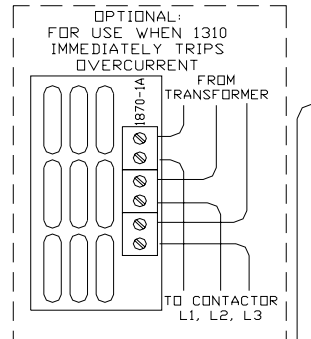
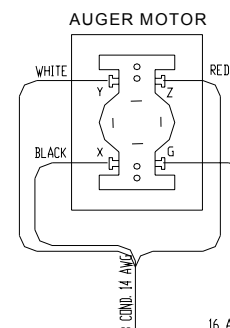
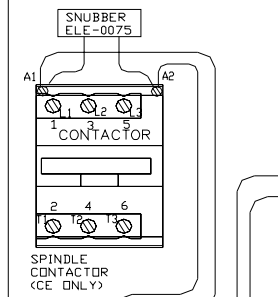

CIRCUIT BREAKER
 15A 00U315
 (IF MORE THAN 15A IS
 REQUIRED BECAUSE
 DATC, PALLET CHANGER,
 AND COOLANT THRU ARE
 ADDED, THEN A SECOND
 CIRCUIT BREAKER WILL
 BE NEEDED.)

NOTE:
 IF MACHINE HAS COOLANT THRU
 SEE WRG-0037.
 IF MACHINE HAS COOLANT THRU,
 DATC, AND PALLET CHANGER,
 A SECOND 15 A CIRCUIT BREAKER
 WILL BE NEEDED.)

T-820 TRANSFORMER

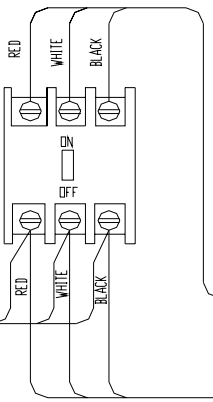
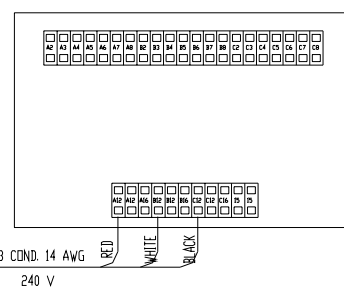

F23 MUST BE 3A FUSE.

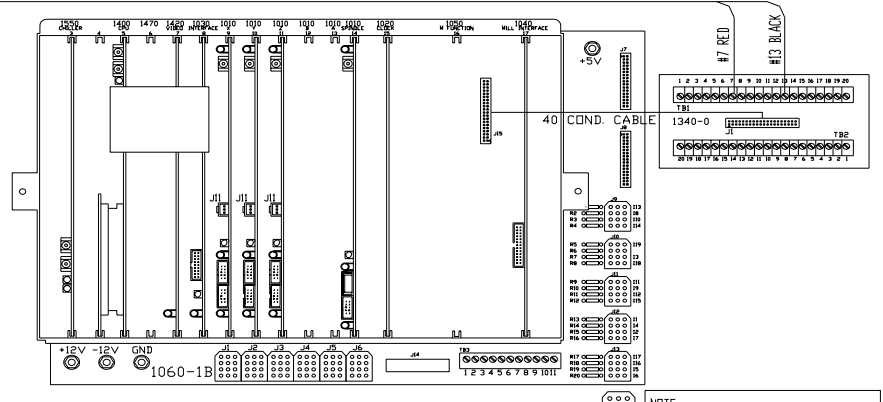
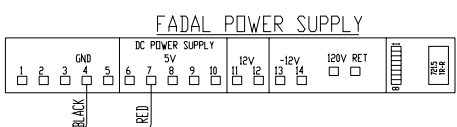
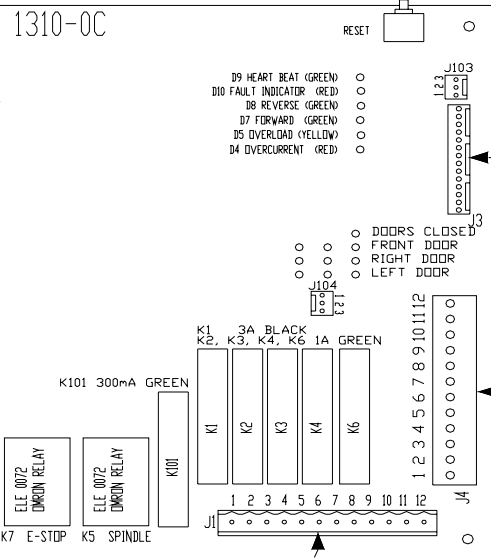
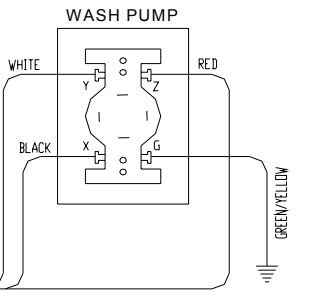
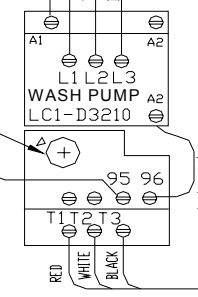

WRG_0001K_Dual_Arm_Tool_Changer_1330-1

IF VOLTAGE OUTPUT SENSORS ARE USED,
USE 3-CONDUCTOR WITH SHIELD CABLE.
THE CONNECTION AT J1 AND J2 WILL BE RED (+V),
WHITE (SIGNAL), BLACK (COM), AND SHIELD.
A JUMPER WILL HAVE TO BE PUT AT J22, J23, J24, AND J25.

TOOL INSERTER INTERLOCK MUST BE
JUMPERED IF MACHINE IS NOT 50 TAPER.
SEE WRG-0047 FOR WIRING OF TOOL
INSERTER INTERLOCK.

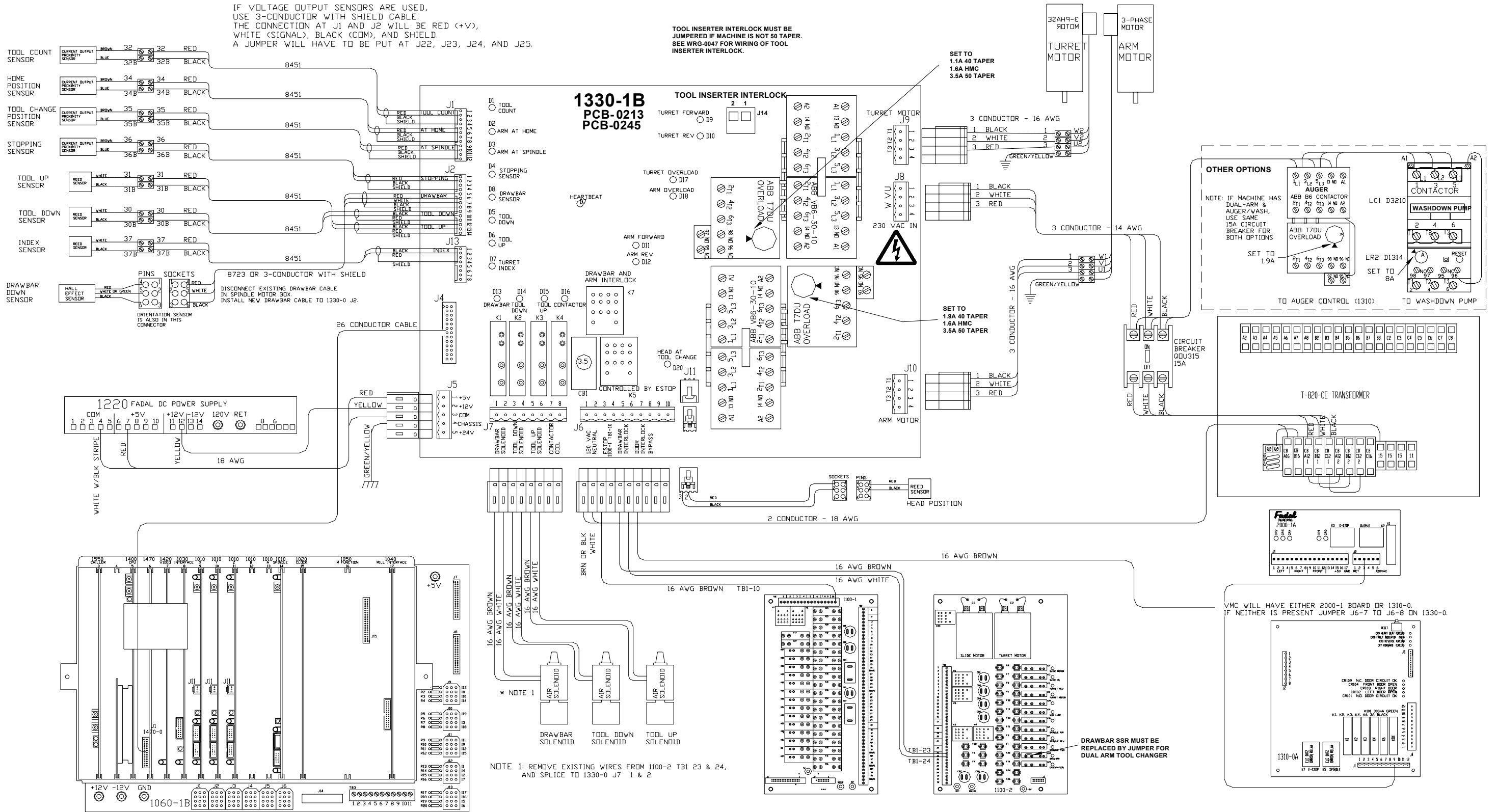

WRG_0044D_6535_washdown

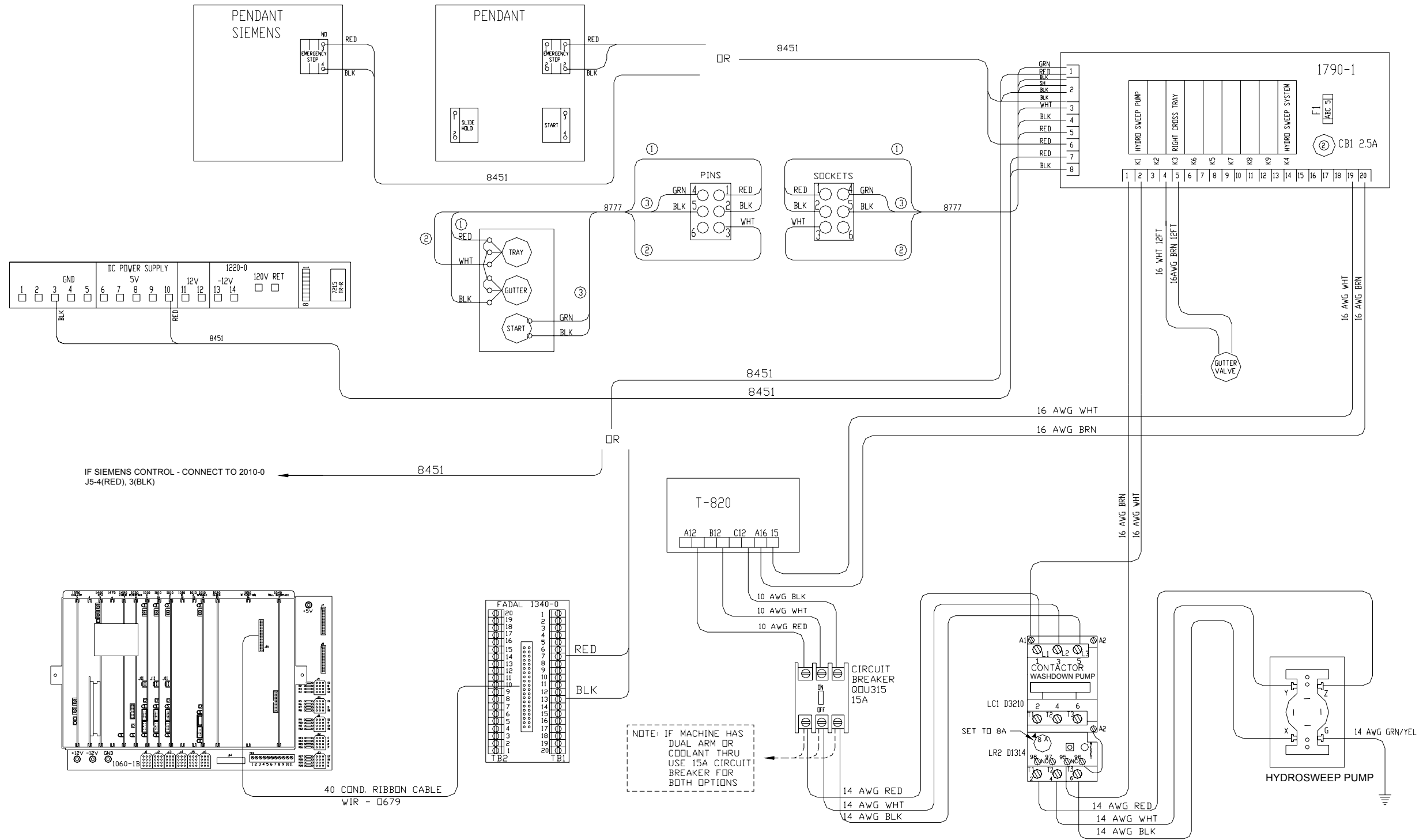

WRG_0045B_CE_wiring_Hennig_Chip_Conveyor

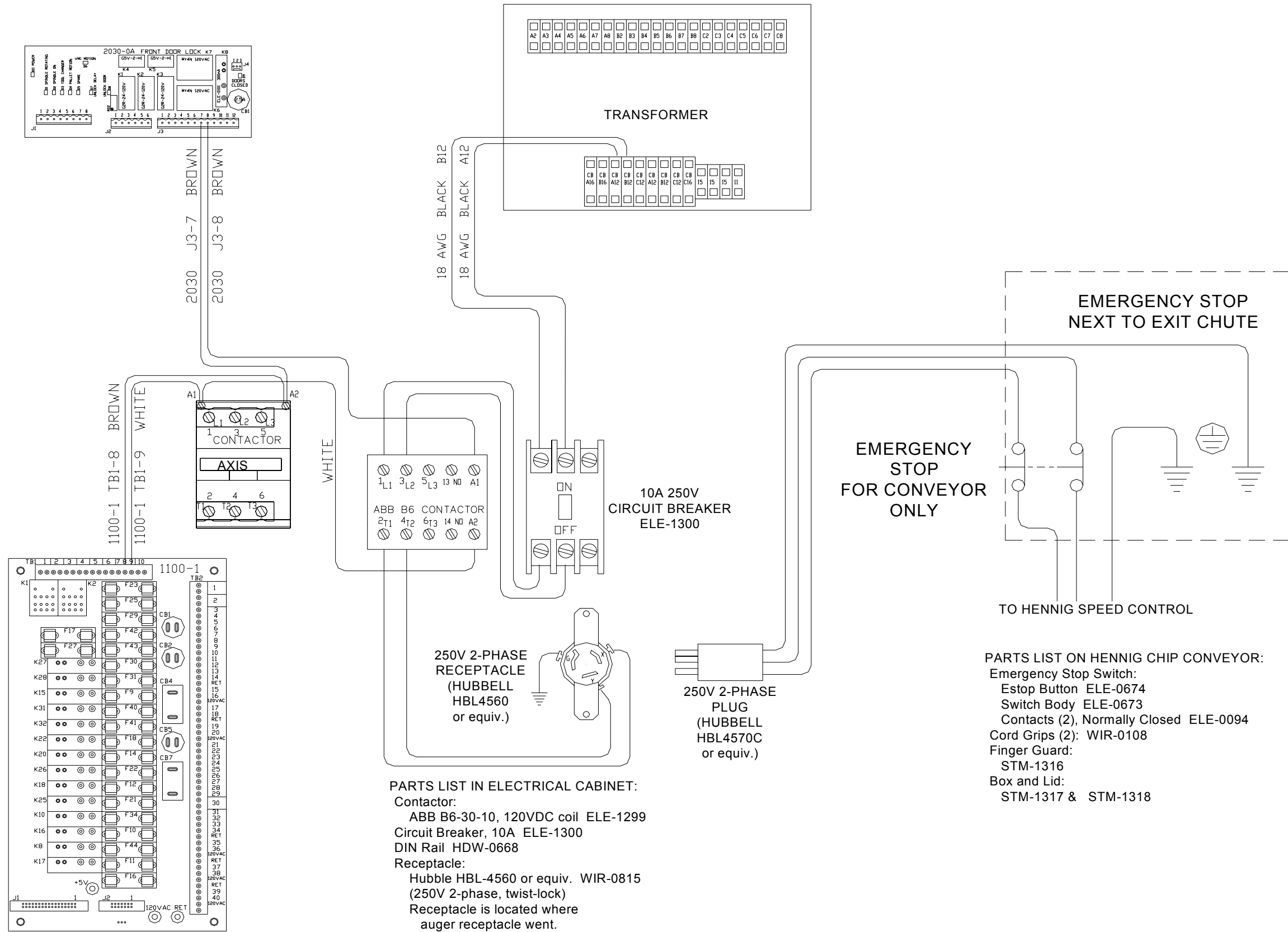

- PARTS LIST IN ELECTRICAL CABINET:**
- Contactor: ABB B6-30-10, 120VDC coil ELE-1299
 - Circuit Breaker, 10A ELE-1300
 - DIN Rail HDW-0668
 - Receptacle: Hubbell HBL-4560 or equiv. WIR-0815 (250V 2-phase, twist-lock)
 - Receptacle is located where auger receptacle went.

- PARTS LIST ON HENNIG CHIP CONVEYOR:**
- Emergency Stop Switch:
 - Estop Button ELE-0674
 - Switch Body ELE-0673
 - Contacts (2), Normally Closed ELE-0094
 - Cord Grips (2): WIR-0108
 - Finger Guard: STM-1316
 - Box and Lid: STM-1317 & STM-1318

WRG_0047F_Remote_TurCW_TurCCW_for_50_Taper

FACEPLATE FOR SWITCHES

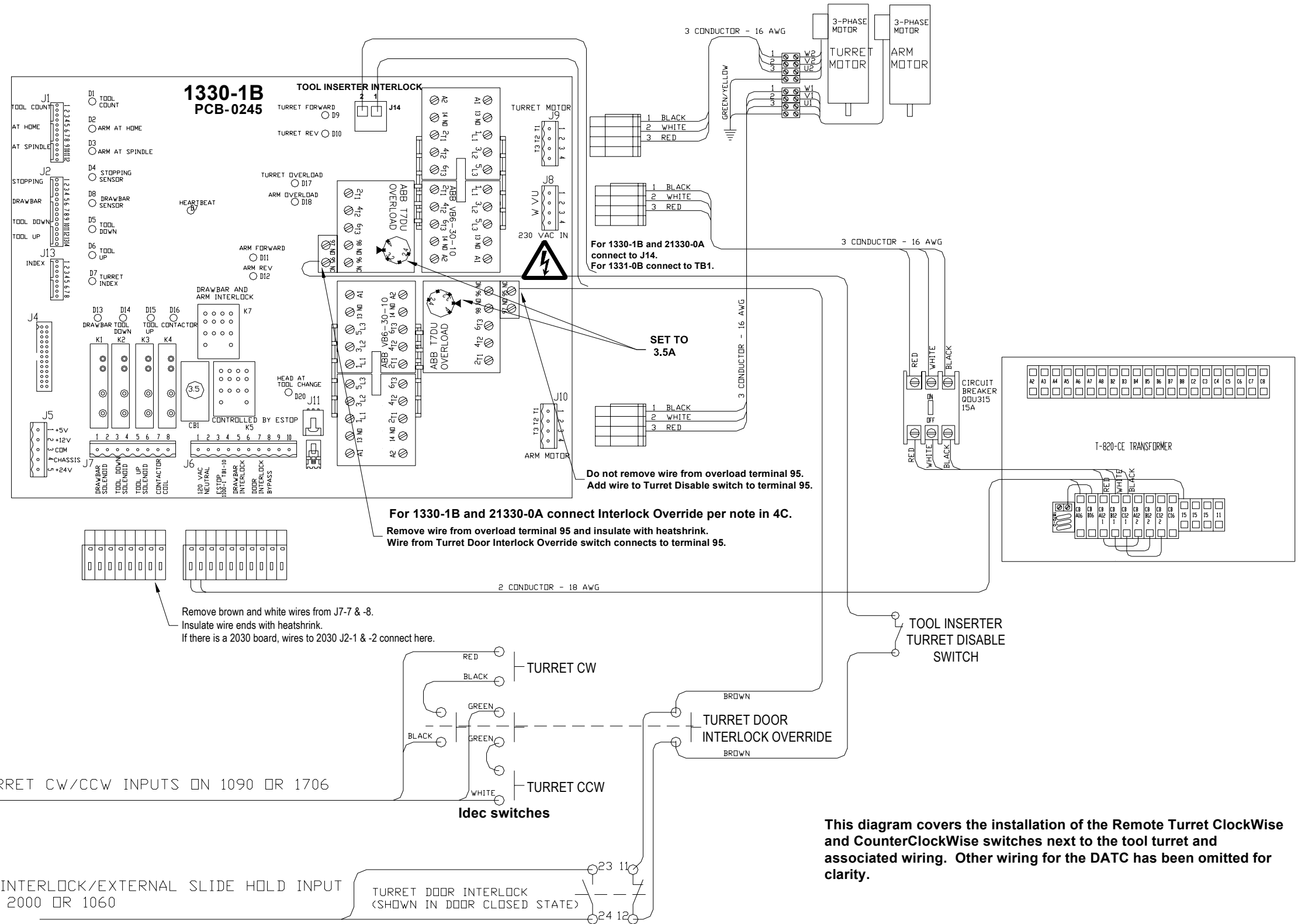
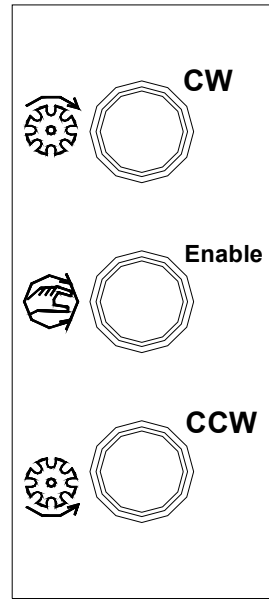

For 1330-1B and 21330-0A connect to J14.
For 1331-0B connect to TB1.

SET TO 3.5A

Do not remove wire from overload terminal 95.
Add wire to Turret Disable switch to terminal 95.

For 1330-1B and 21330-0A connect Interlock Override per note in 4C.
Remove wire from overload terminal 95 and insulate with heatshrink.
Wire from Turret Door Interlock Override switch connects to terminal 95.

Remove brown and white wires from J7-7 & -8.
Insulate wire ends with heatshrink.
If there is a 2030 board, wires to 2030 J2-1 & -2 connect here.

TO REMOTE TURRET CW/CCW INPUTS ON 1090 OR 1706

TO DOOR INTERLOCK/EXTERNAL SLIDE HOLD INPUT ON 1310, 2000 OR 1060

This diagram covers the installation of the Remote Turret ClockWise and CounterClockWise switches next to the tool turret and associated wiring. Other wiring for the DATC has been omitted for clarity.

Interlock switch:
Pizzato FR692-D1,
Omron D4DS-35FS,
or equivalent

Wrg_0050A_air_oil_system_50tap

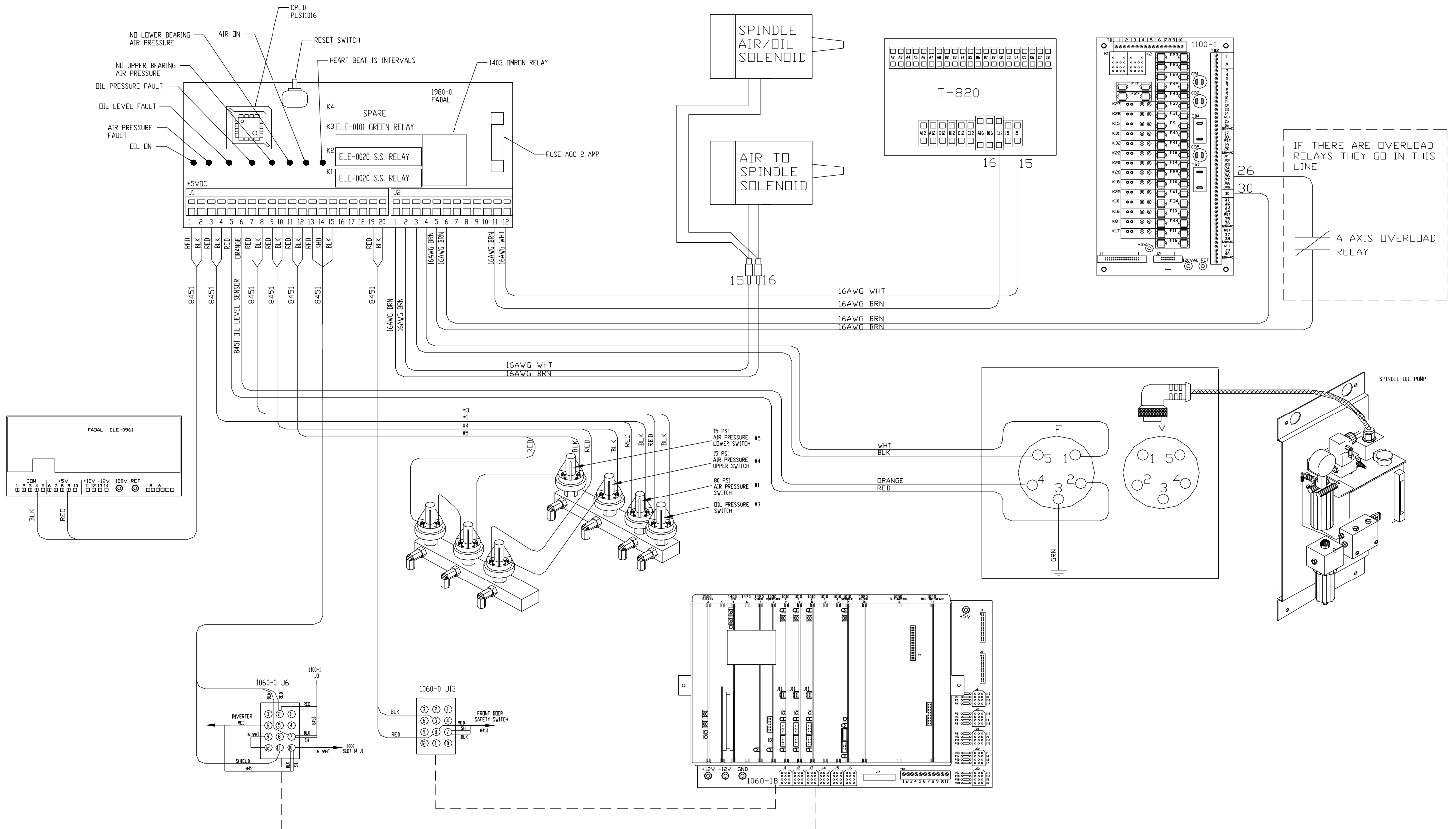

Wrg_0051A_15_pin_connector_50tap

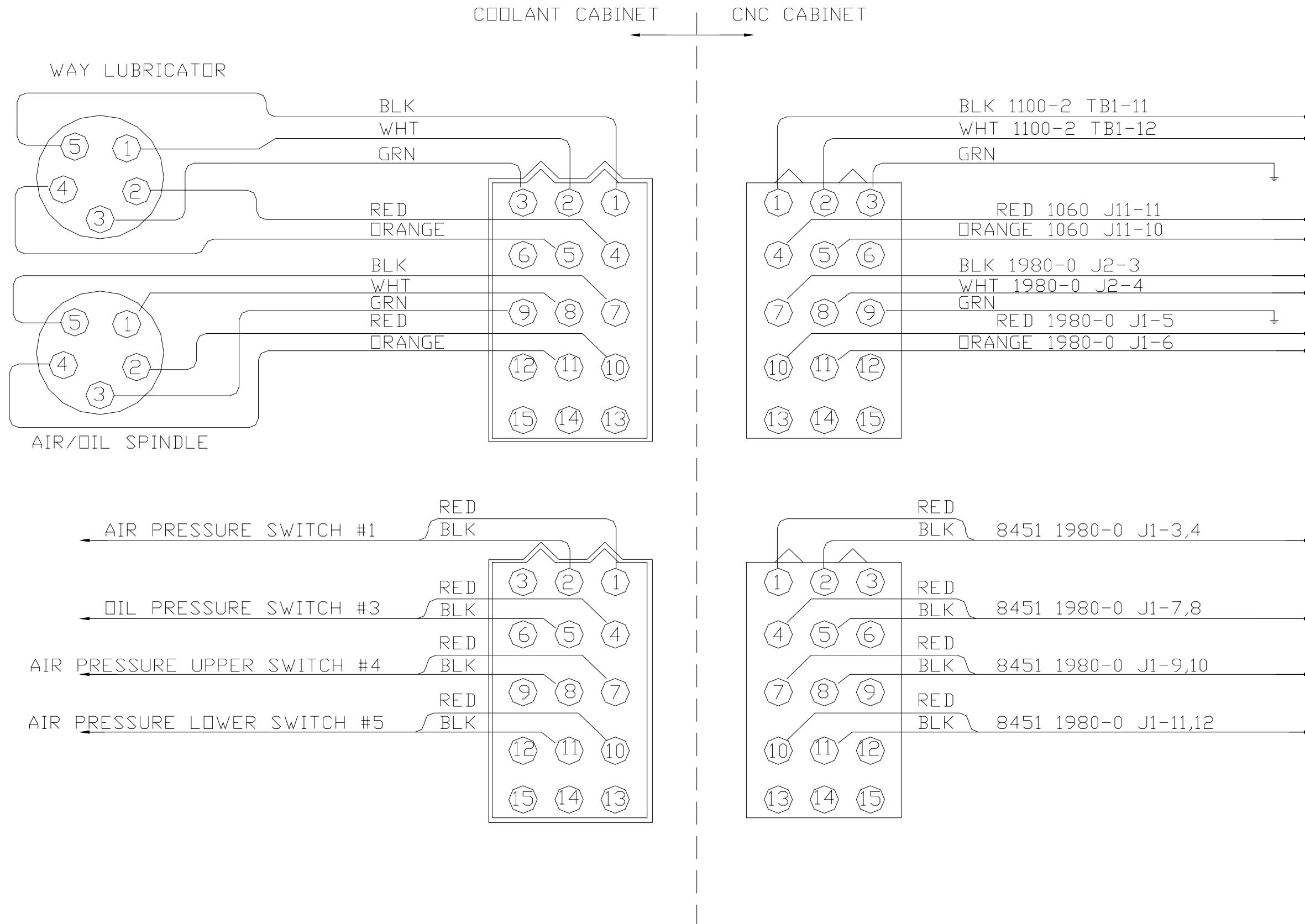

SECTION 6

Pendant

WRG_0020D_pendant_wiring_1990_1_board

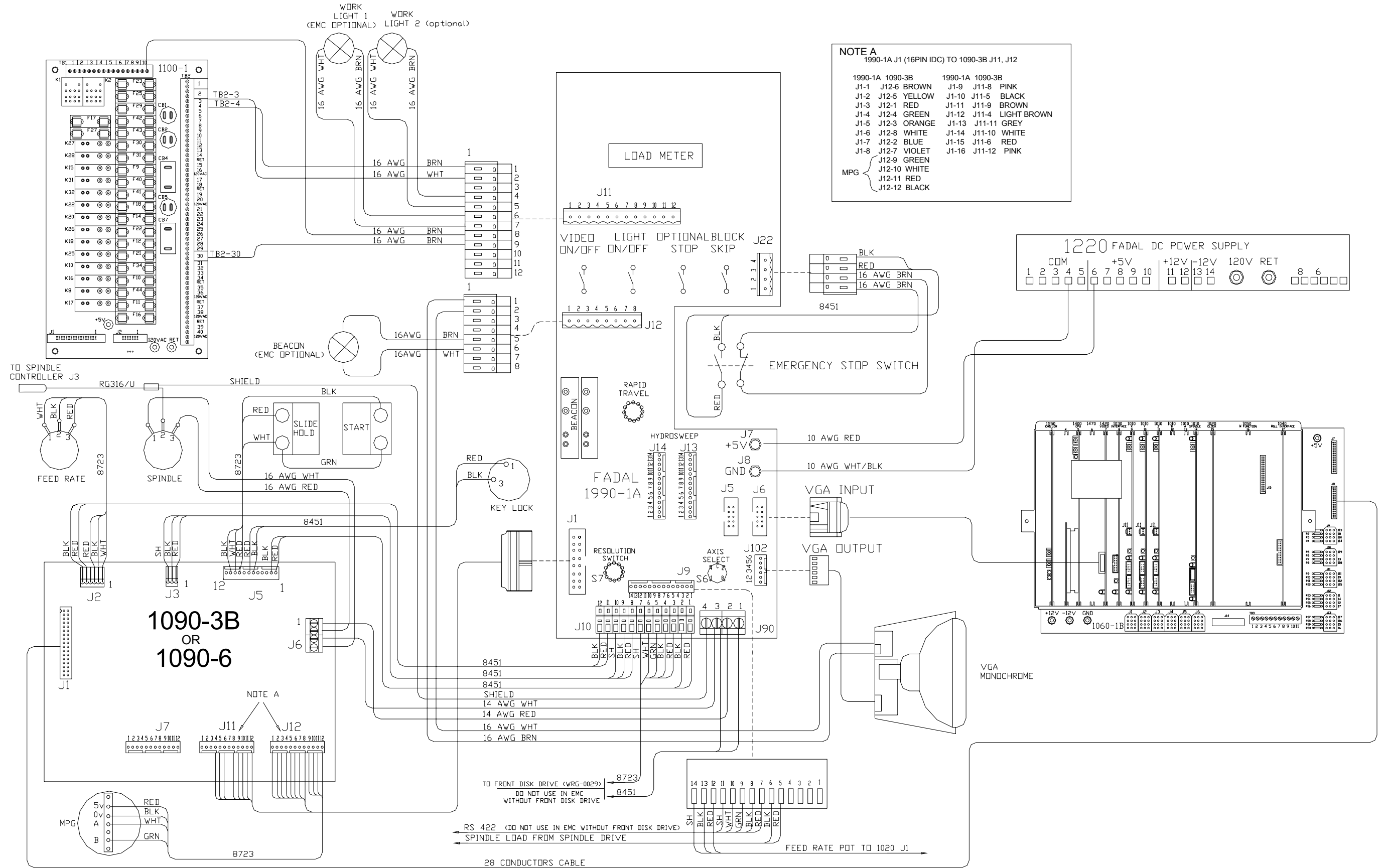

WRG_0021B_1990_2_board_32mp

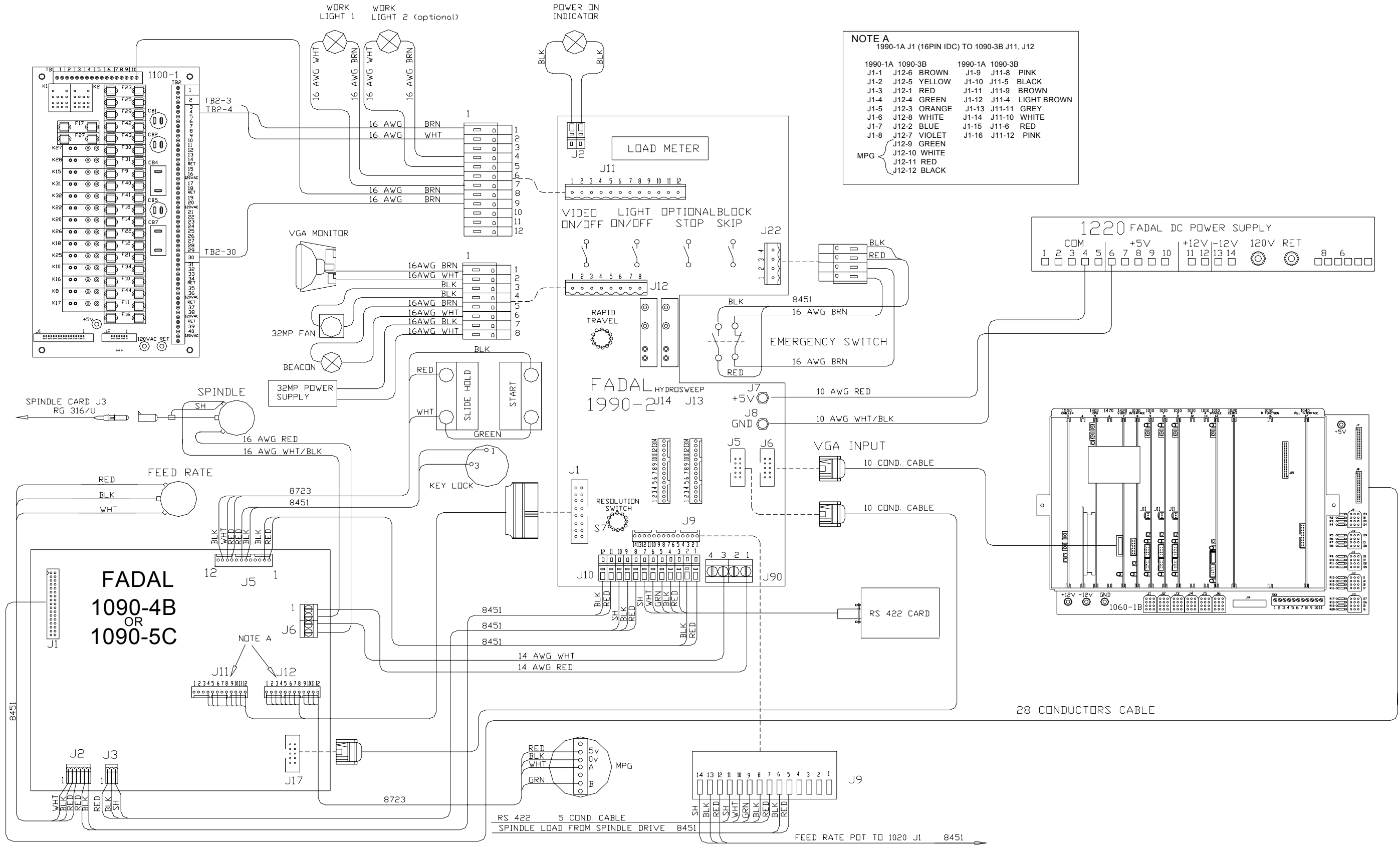

CNC 88/MULTI PROCESSOR

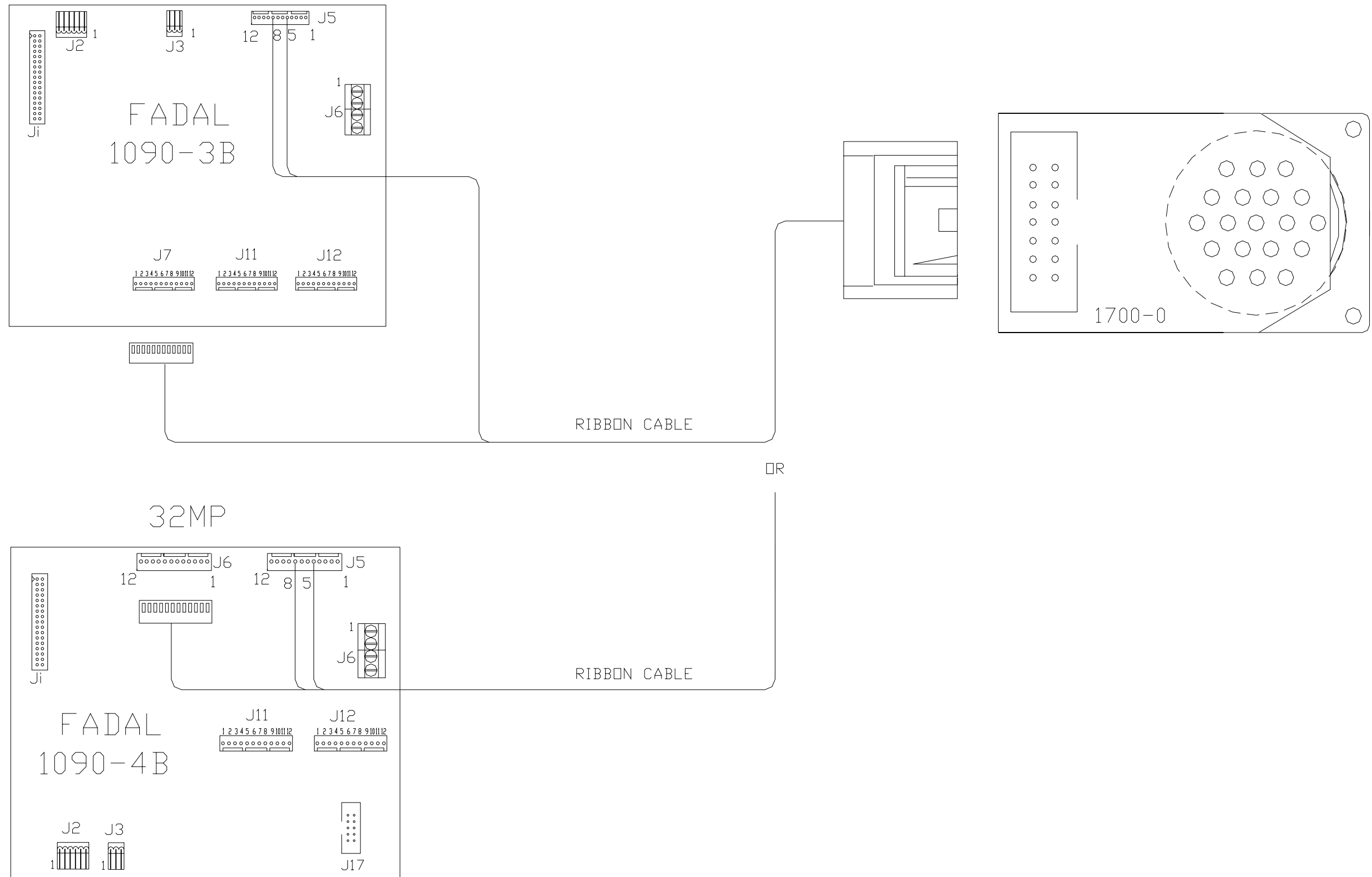

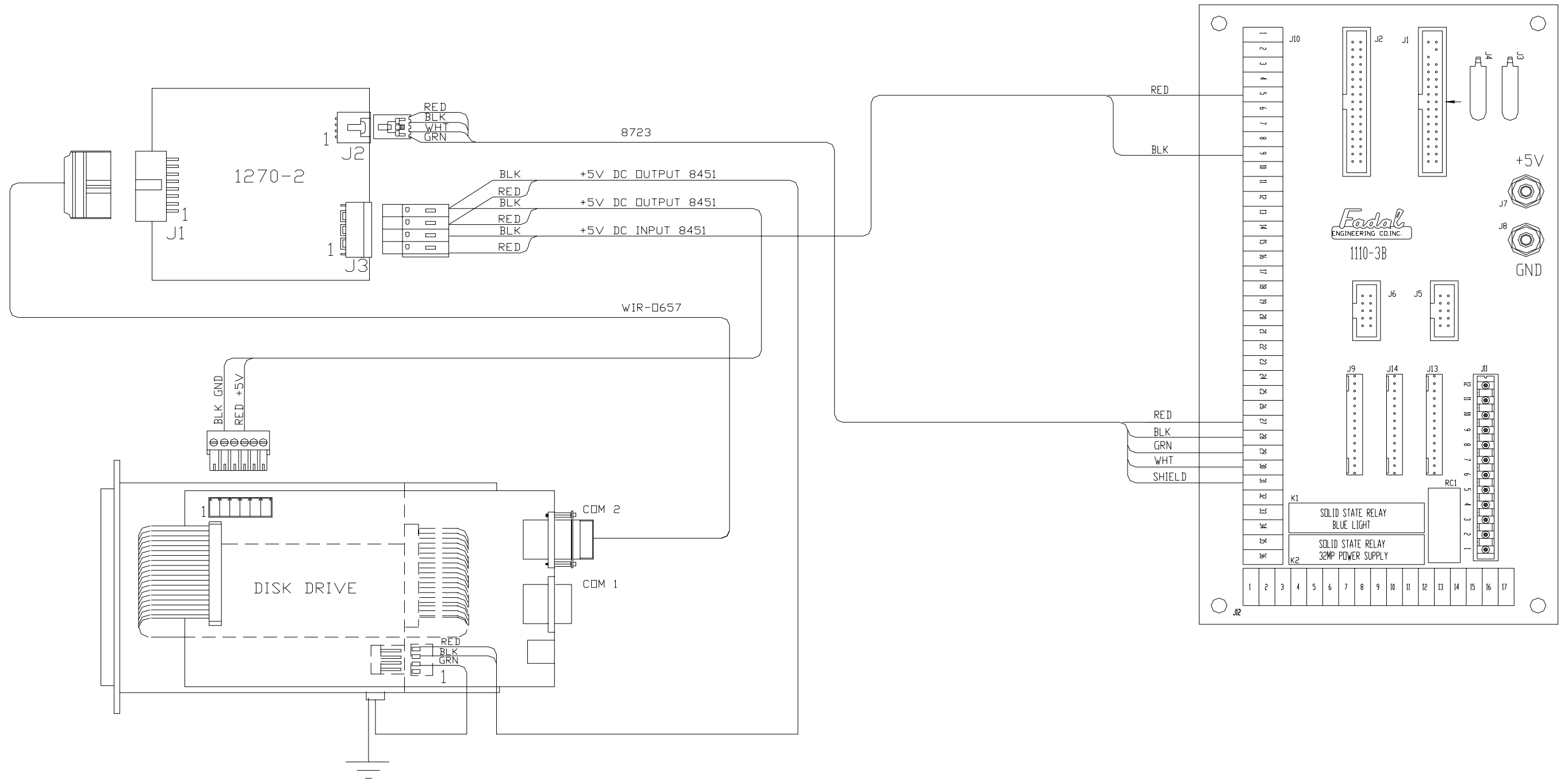

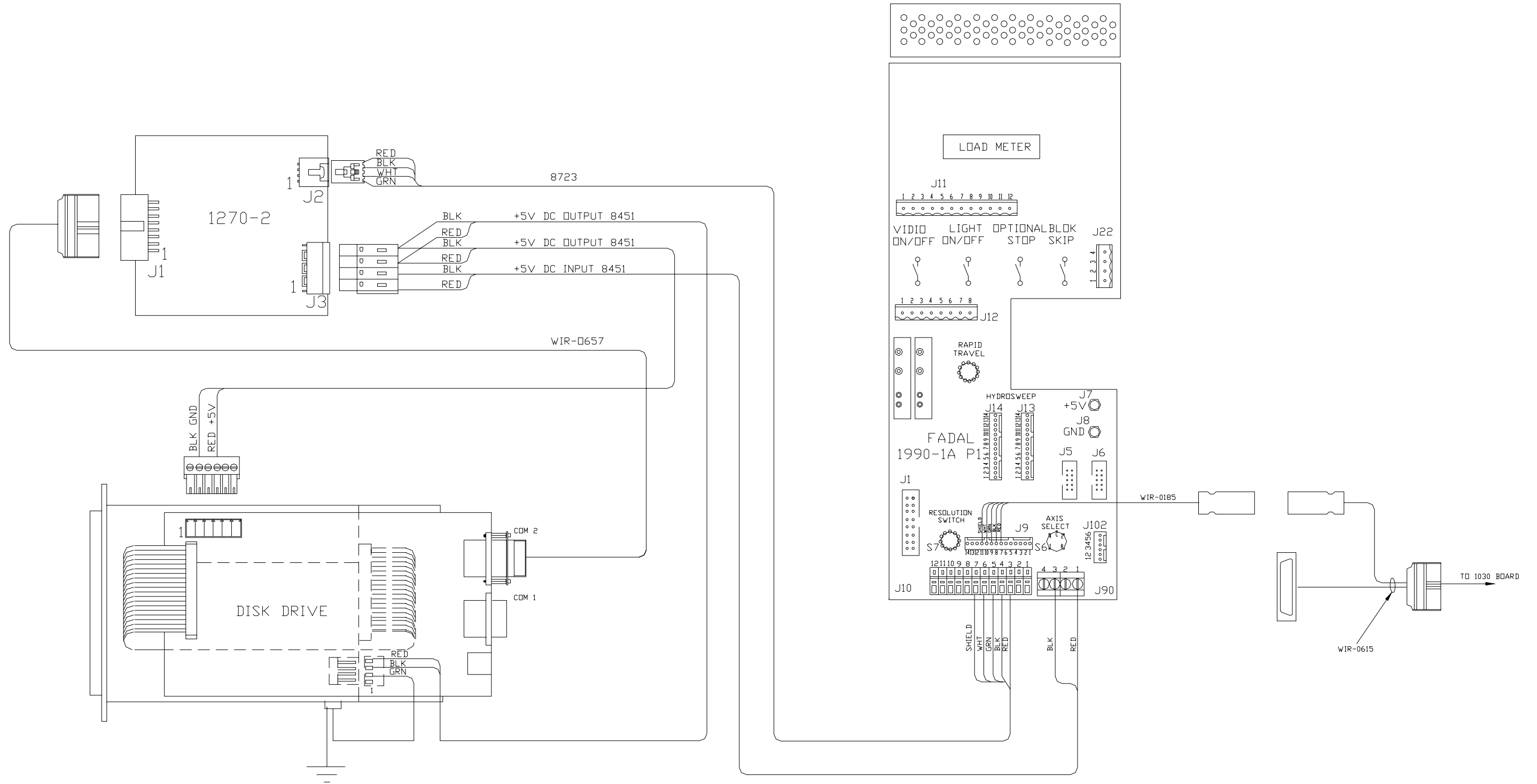

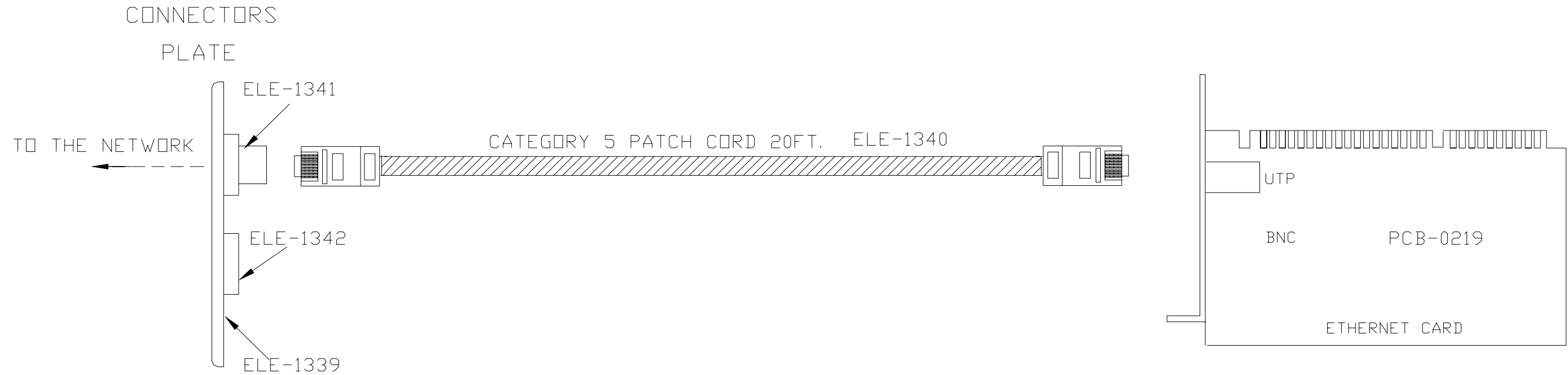

NOTE:

1. Install the Ethernet card into the PC chassis frame in 32MP control.
2. Install the connectors plate on the right bottom side of CNC cabinet for standard sheet metal and on the left bottom side of CNC cabinet for SLANT 98.
3. If the PC mother board is ETHERNET ready, connect the ETHERNET cables to the appropriate terminals on mother board.

WRG_0057B_pendant_wiring_LCD_monitor

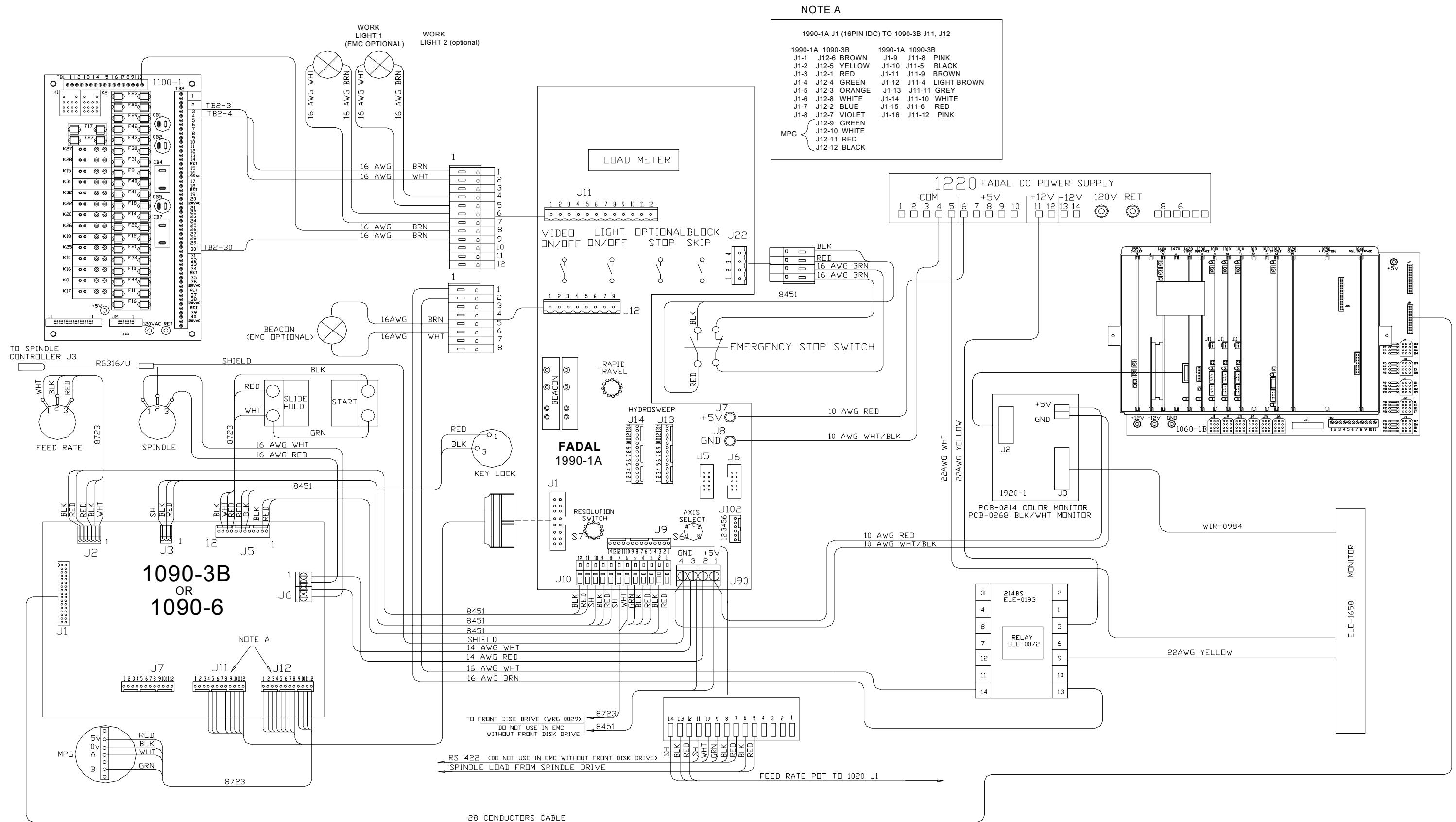

SECTION 7

Transformers

Lbl_0026C_label_t818_transformer_340-510V

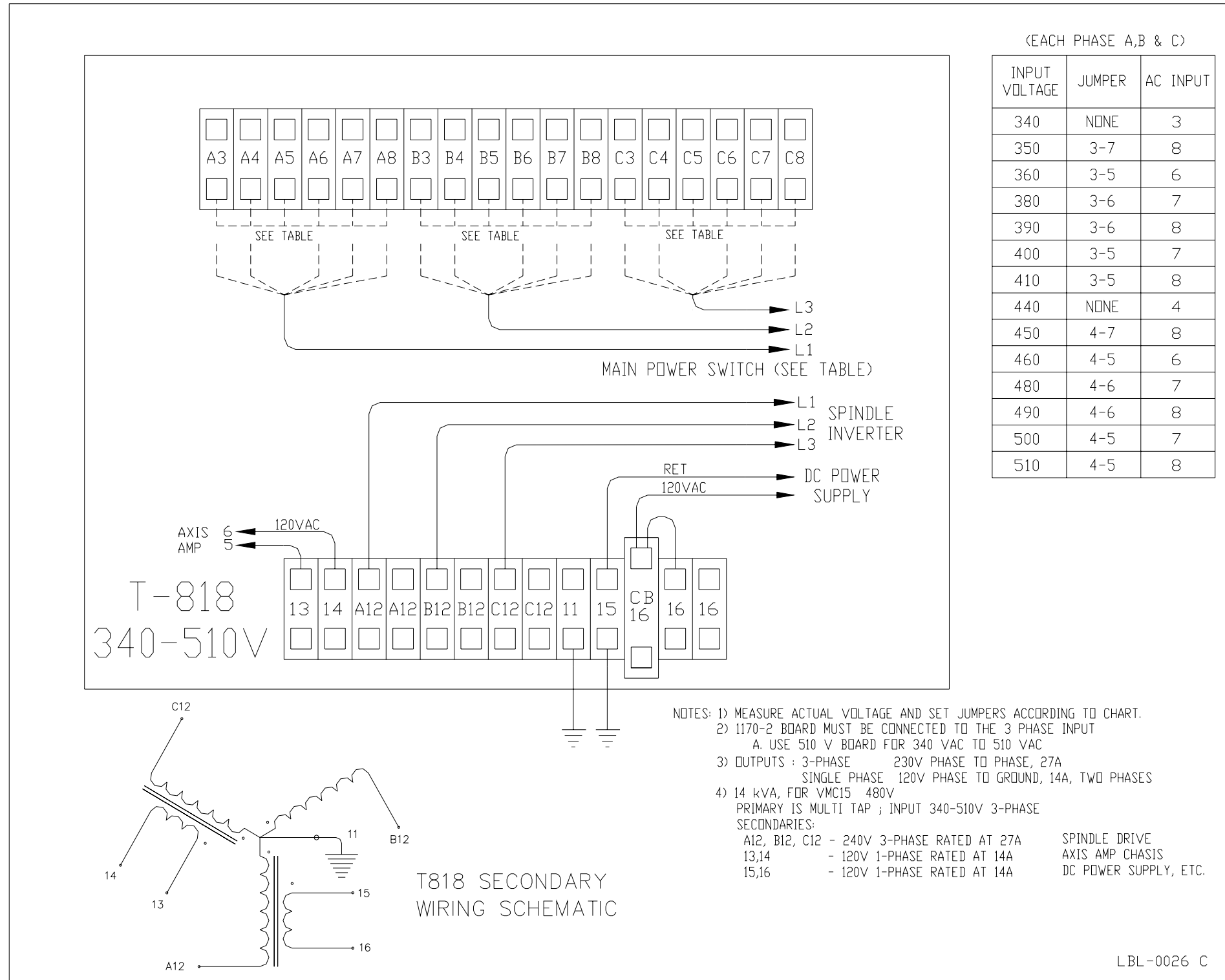

Lbl_0027D_label_t820_transformer_190-510V

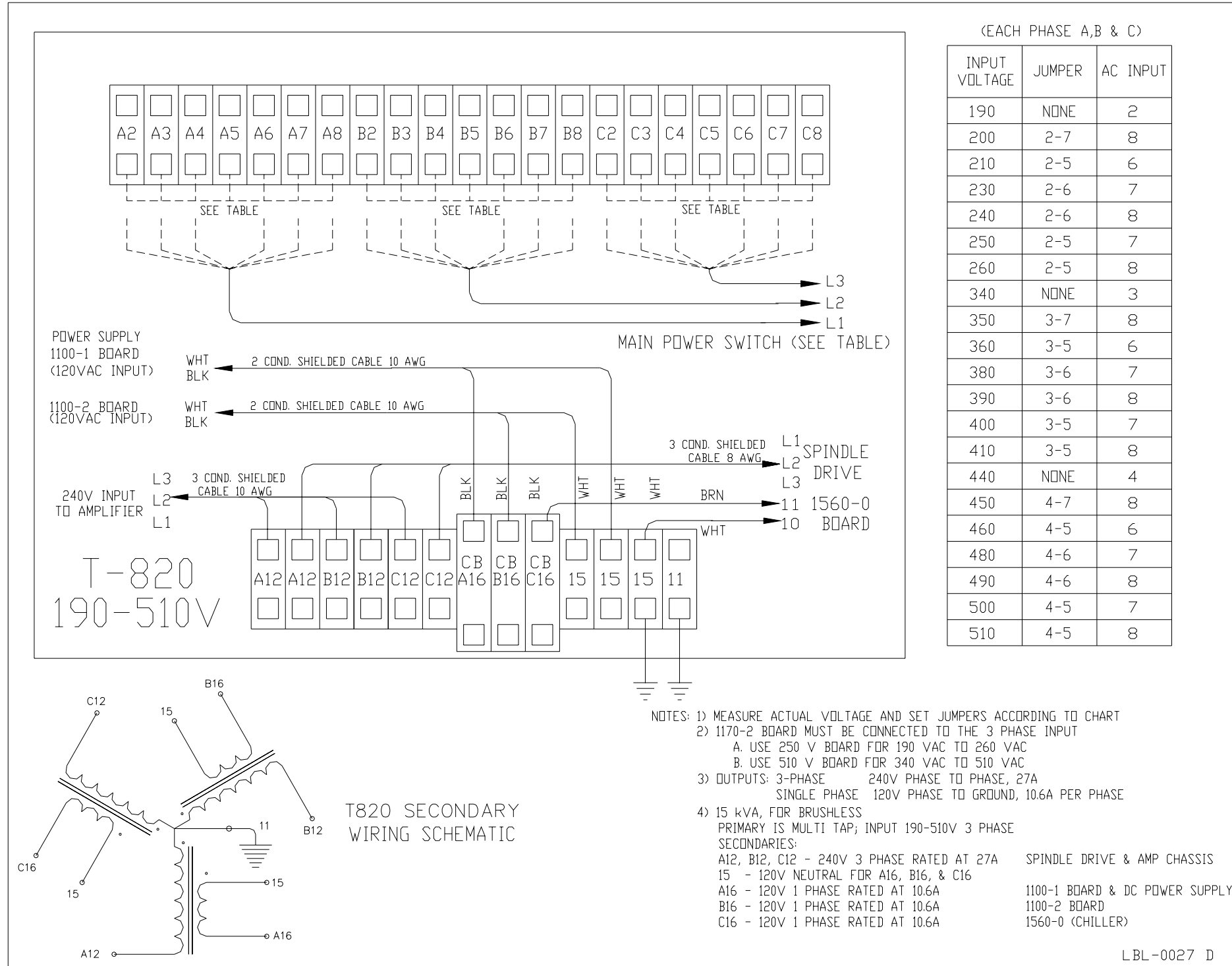

(EACH PHASE A,B & C)

INPUT VOLTAGE	JUMPER	AC INPUT
190	NONE	2
200	2-7	8
210	2-5	6
230	2-6	7
240	2-6	8
250	2-5	7
260	2-5	8
340	NONE	3
350	3-7	8
360	3-5	6
380	3-6	7
390	3-6	8
400	3-5	7
410	3-5	8
440	NONE	4
450	4-7	8
460	4-5	6
480	4-6	7
490	4-6	8
500	4-5	7
510	4-5	8

Lbl_0278D_label_t818ce_transformer_340-510V

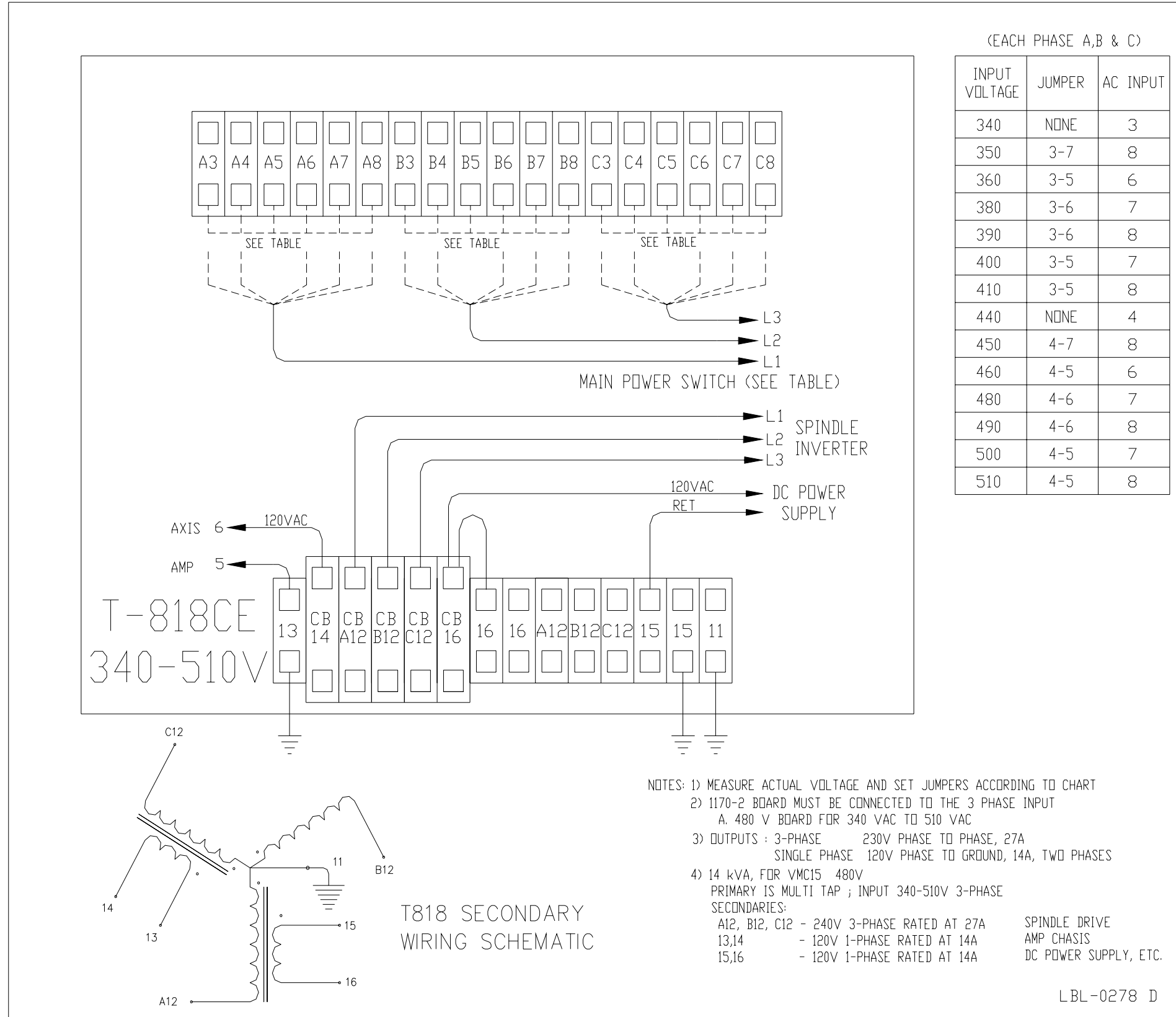

LBL_0279D_label_t812_transformer 240V

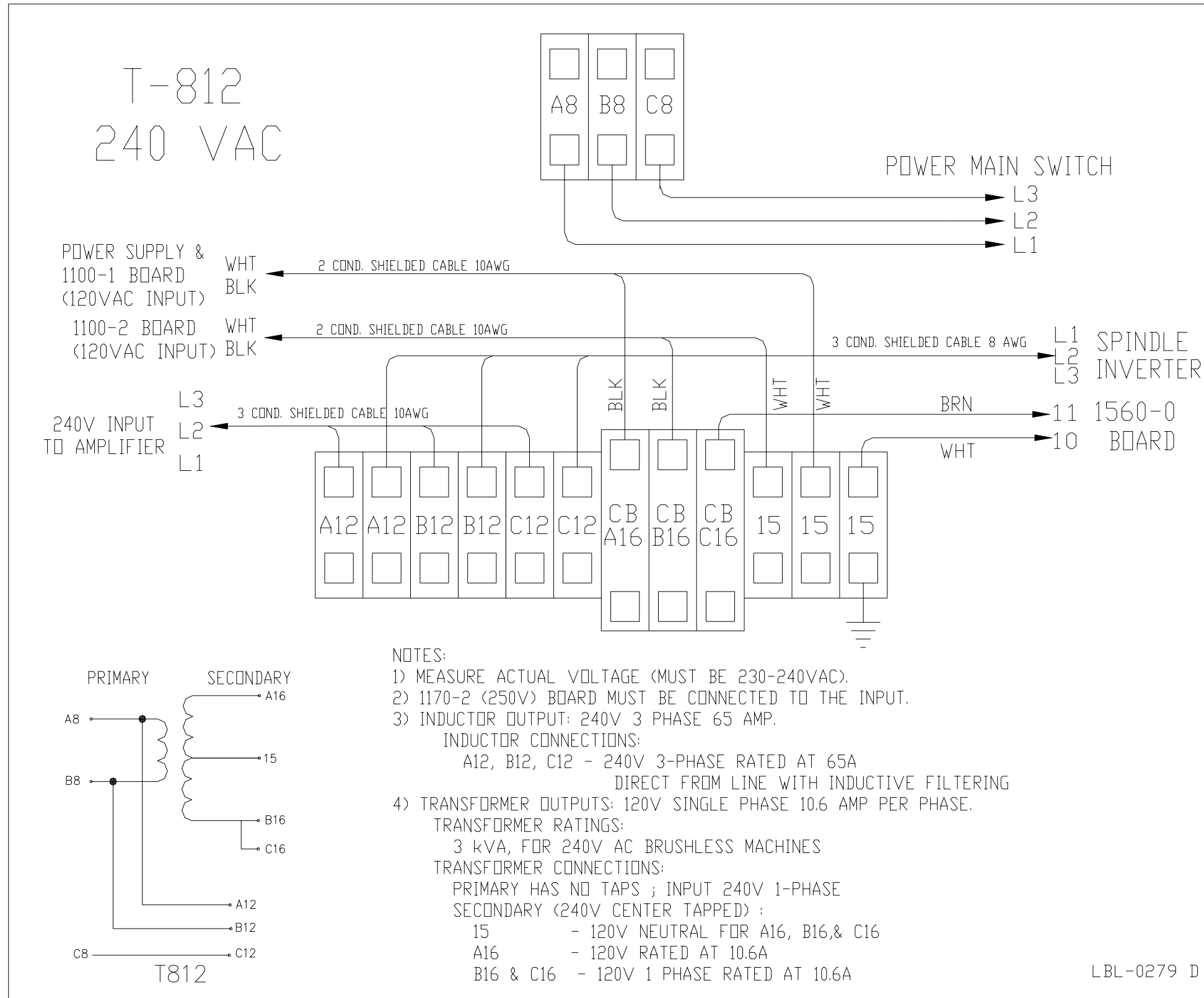

LBL_0280D_label_t812_transformer_single_phs_ac_240V

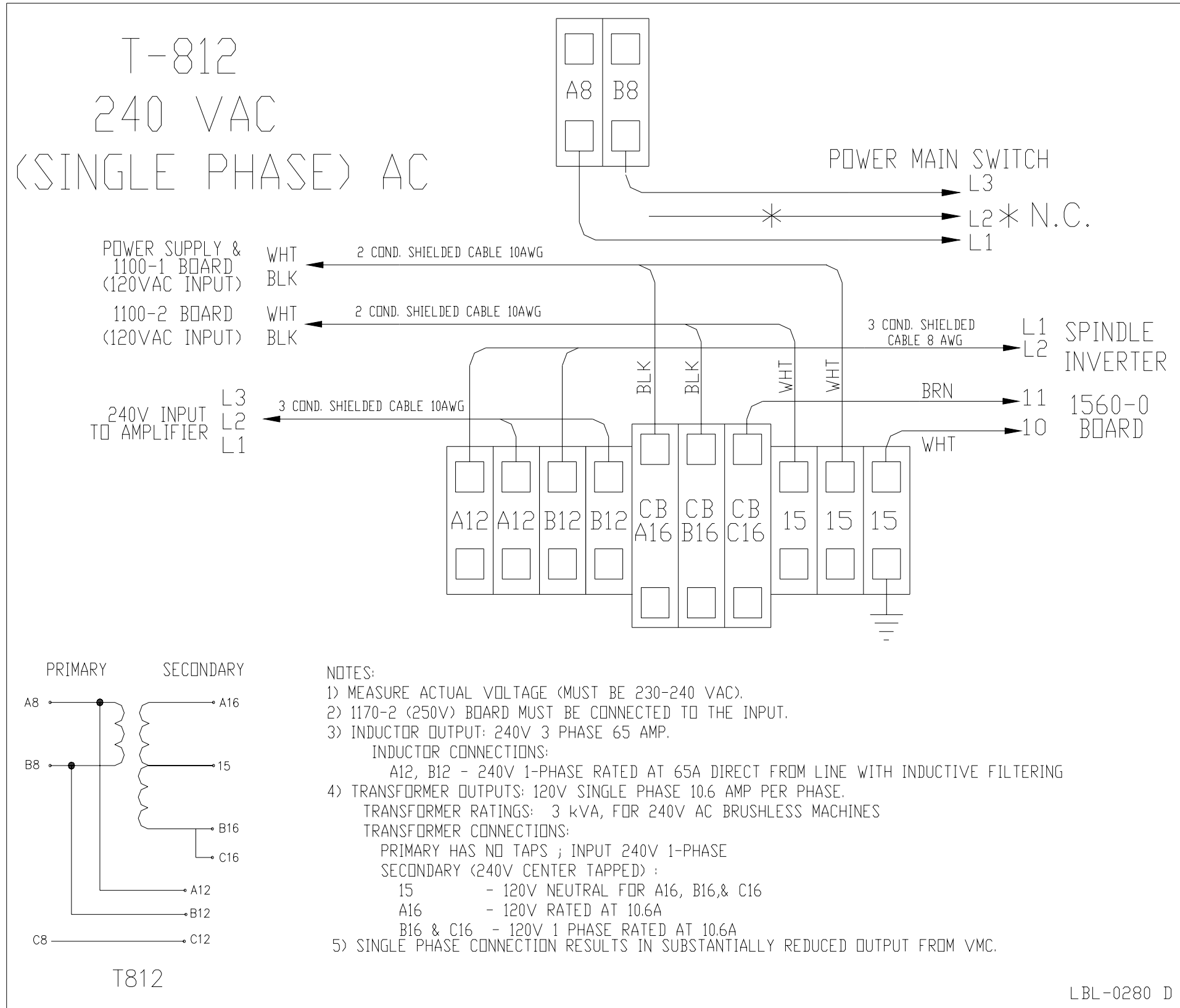

LBL_0285D_label_t812_transformer_single_phs_dc_240V

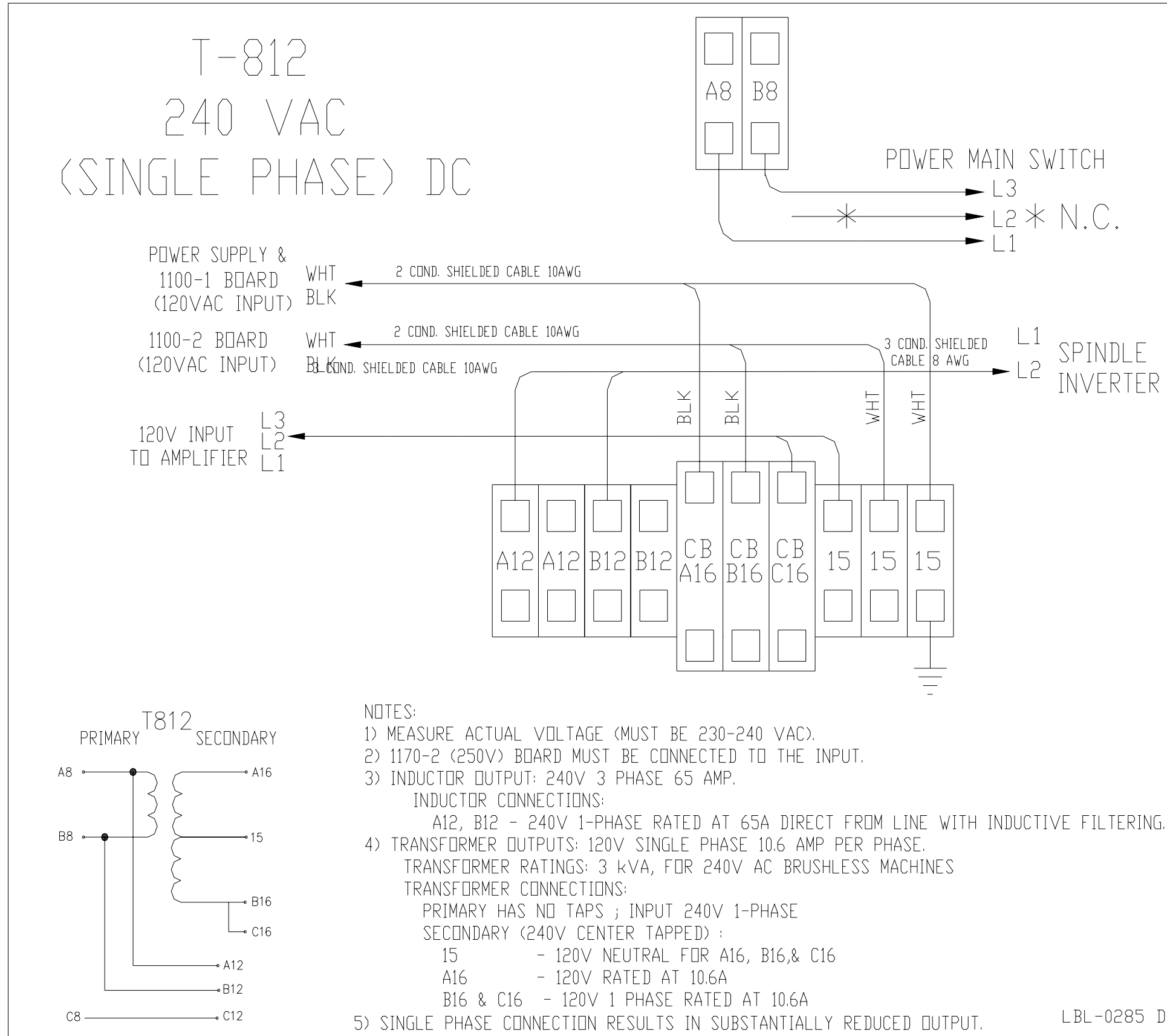

WRG_0042A_TransformerThermalSwitch

MATERIAL LIST:

- Omron relay socket (#PYF14A-E) (ELE-1440)
- Omron MY4N relay 110VAC coil (ELE-0072)
- Selco thermal switches (2) (UP62-120C or UP72-120C) (ELE-1441)
- (Switches may be for any temperature rating from 110C to 120C)
- 16AWG brown wire (2 pieces 8.5 feet long)
- 18AWG white wire (1 piece 12 inches long)
- 18AWG brown wire (2 pieces, 15 and 10 inches)
- Crimp connector (WIR-0190)
- Loctite Blue RTV Silicone Adhesive

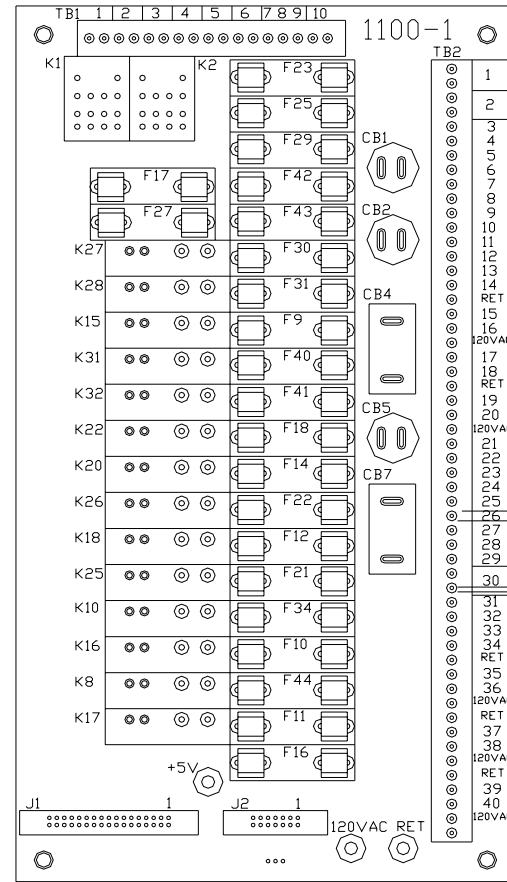

REMOVE JUMPER TB2 26 TO 30

1100-1 TB2-26
1100-1 TB2-30

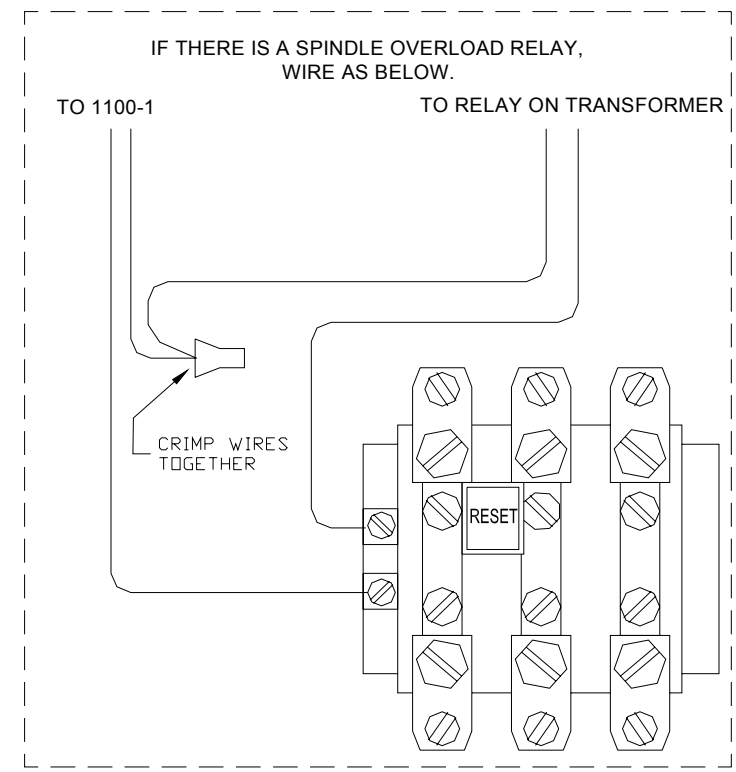

IF THERE IS A SPINDLE OVERLOAD RELAY, WIRE AS BELOW.

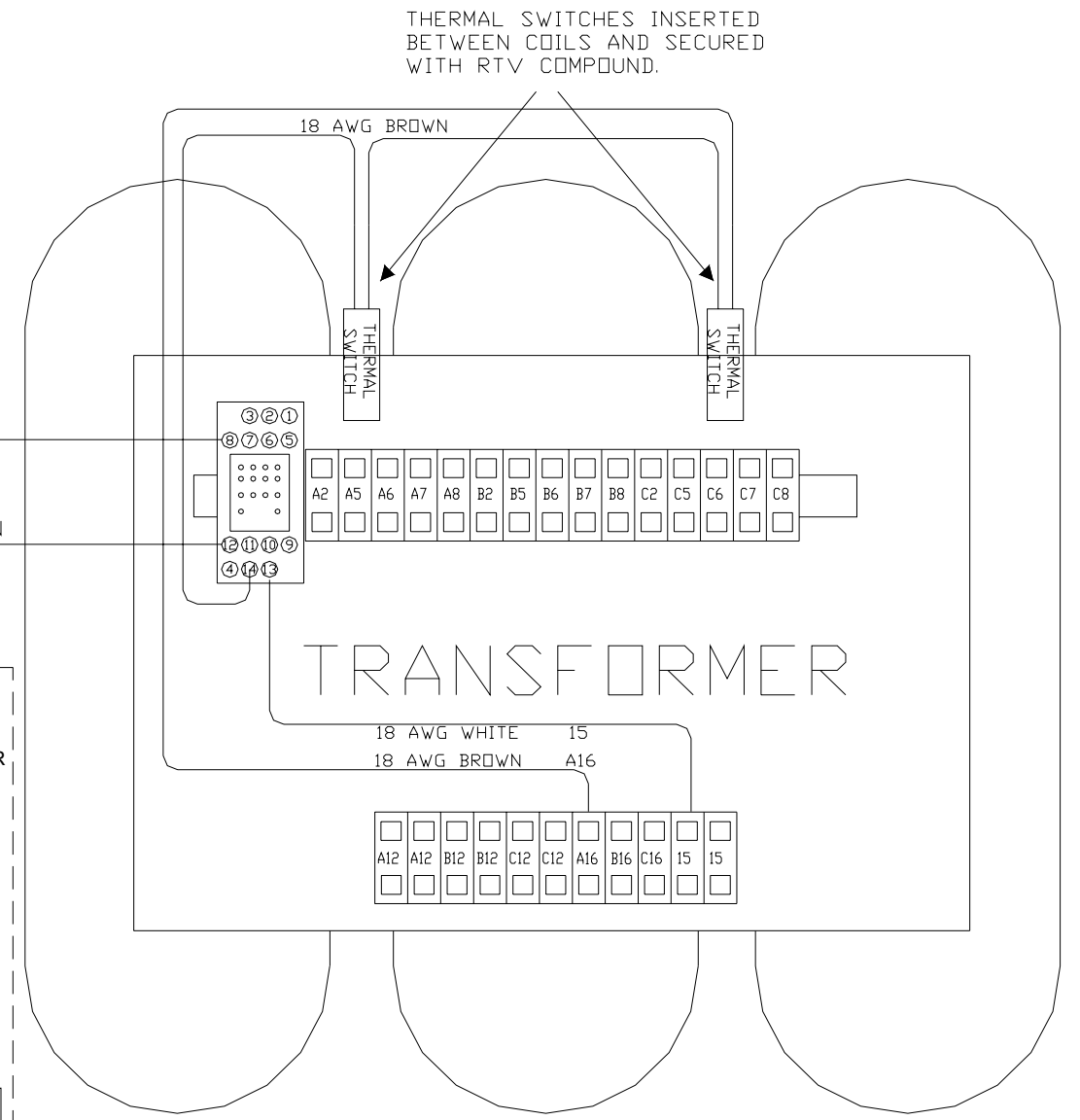

THERMAL SWITCHES INSERTED BETWEEN COILS AND SECURED WITH RTV COMPOUND.

1. TURN OFF POWER.
2. ATTACH RELAY SOCKET TO UPPER DIN RAIL ON TRANSFORMER. (ON T820, YOU MAY NEED TO SLIDE WAGO TERMINALS TO THE RIGHT.)
3. CONNECT BROWN WIRE MARKED "A16" TO THE LOAD SIDE OF THE A16 CIRCUIT BREAKER.
4. CONNECT WHITE WIRE MARKED "15" TO TERMINAL 15 ON THE TRANSFORMER.
5. FIND LOCATION WHERE THERMAL SWITCH WILL SLIP BETWEEN TRANSFORMER COILS (SHOULD BE SNUG).
6. APPLY HIGH TEMPERATURE RTV SILICONE SEALANT TO THERMAL SWITCH AND INSERT BETWEEN COILS OF TRANSFORMER. PUSH INTO POSITION WITH SMALL SCREWDRIVER IF NEEDED.
7. APPLY ADDITIONAL HIGH TEMPERATURE RTV SILICONE SEALANT OVER SWITCH TO HOLD SWITCH IN PLACE AND TO INSULATE IT FROM THE AIR ABOVE. BEAD ABOVE SWITCH SHOULD BE AT LEAST 1/4" THICK.
7. IF VMC HAS A THERMAL OVERLOAD RELAY FOR THE SPINDLE MOTOR CONNECT THE TWO WIRES MARKED "1100-1 TB2-26" AND "1100-1 TB2-30" AS SHOWN IN THE DOTTED BOX AND CONTINUE AT STEP 11.
8. ROUTE THE TWO WIRES MARKED "1100-1 TB2-26" AND "1100-1 TB2-30" TO THE 1100-1 BOARD.
9. REMOVE THE JUMPER WIRE FROM 1100-1 TB2 TERMINAL 26 TO 30.
10. CONNECT "TB2-26" WIRE TO TB2 TERMINAL 26 ON THE 1100-1 AND WIRE "TB2-30" TO TERMINAL 30. (THIS IS WHERE YOU REMOVED THE JUMPER WIRE FROM.)
11. POWER ON MACHINE. RELAY SHOULD BE ON AND MACHINE SHOULD NOT BE IN EMERGENCY STOP. WHEN THE TRANSFORMER EXCEEDS 130 DEGREES C, THE THERMAL SENSORS WILL OPEN, THE RELAY WILL GO OFF, AND THE MACHINE WILL ENTER EMERGENCY STOP UNTIL THE TRANSFORMER COOLS BELOW 90 DEGREES C.
12. TEST: REMOVE THE RELAY FROM THE SOCKET; VMC SHOULD GO INTO EMERGENCY STOP. (SINCE THE TRANSFORMER WILL NOT NORMALLY REACH A TEMPERATURE TO TRIP THE THERMAL SWITCHES, THIS IS THE ONLY WAY TO TEST THE WIRING.)

Wrg_0054A_6535_50tap_siemens810_Std

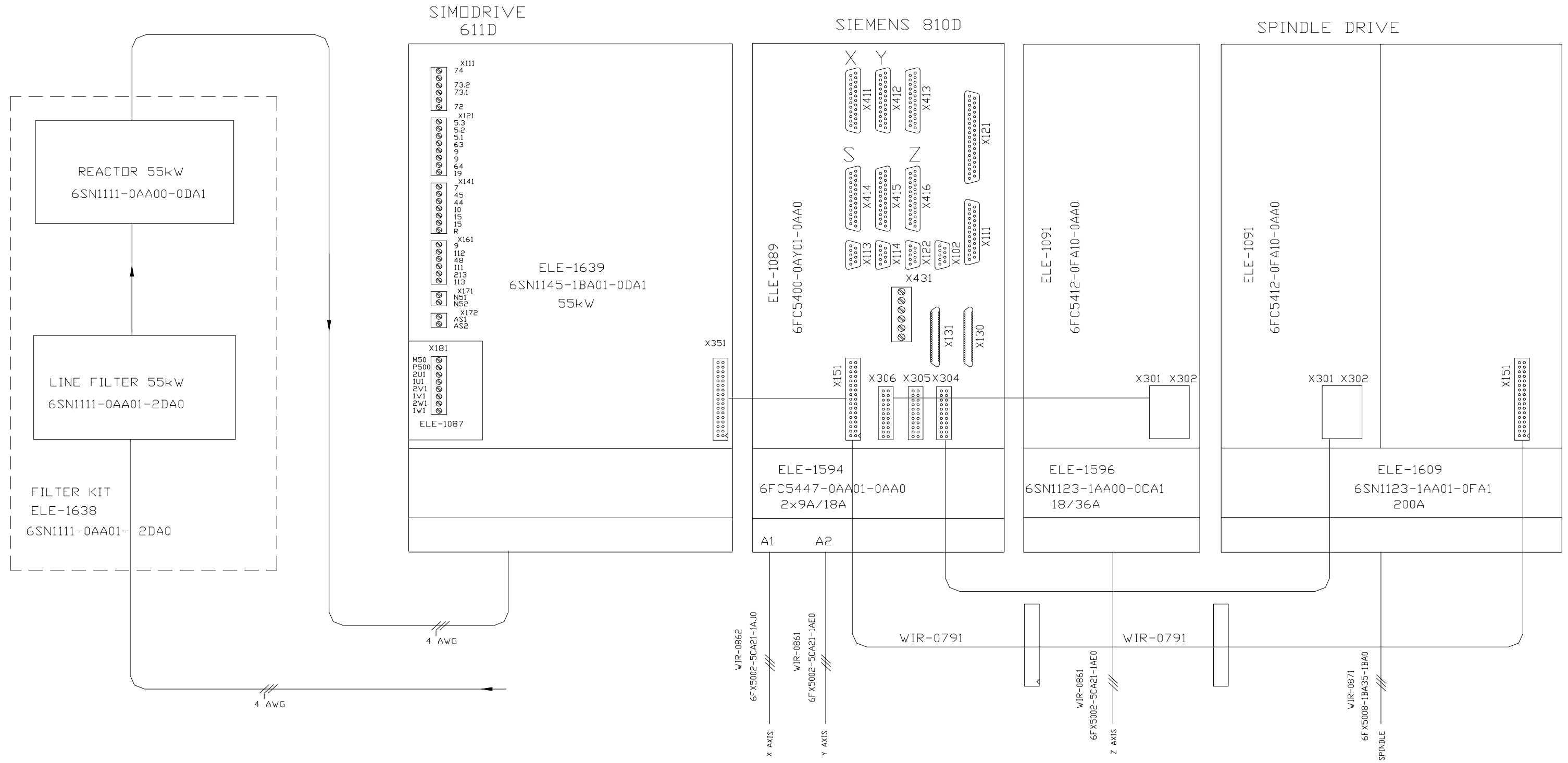

NOTE: - X, Y, Z AXES MOTOR - MTR-0224 1FT6086-8AC71-1AG0
 - SPINDLE MOTOR - MTR-0225 1PH7167-2ND03-0DB0
 - Y, Z AXES SIGNAL CABLE - WIR-0741 6FX5002-2CA31-1AE0
 - X AXIS SIGNAL CABLE - WIR-0742 6FX5002-2CA31-1AJ0
 - Y, Z AXES POWER CABLE - WIR-0861 6FX5002-5CA21-1AE0
 - X AXIS POWER CABLE - WIR-0862 6FX5002-2CA21-1AJ0
 - MAIN POWER DISCONNECT 100A ELE-1600

Wrg_0066A_6535_50tap_siemens810_rot_scale

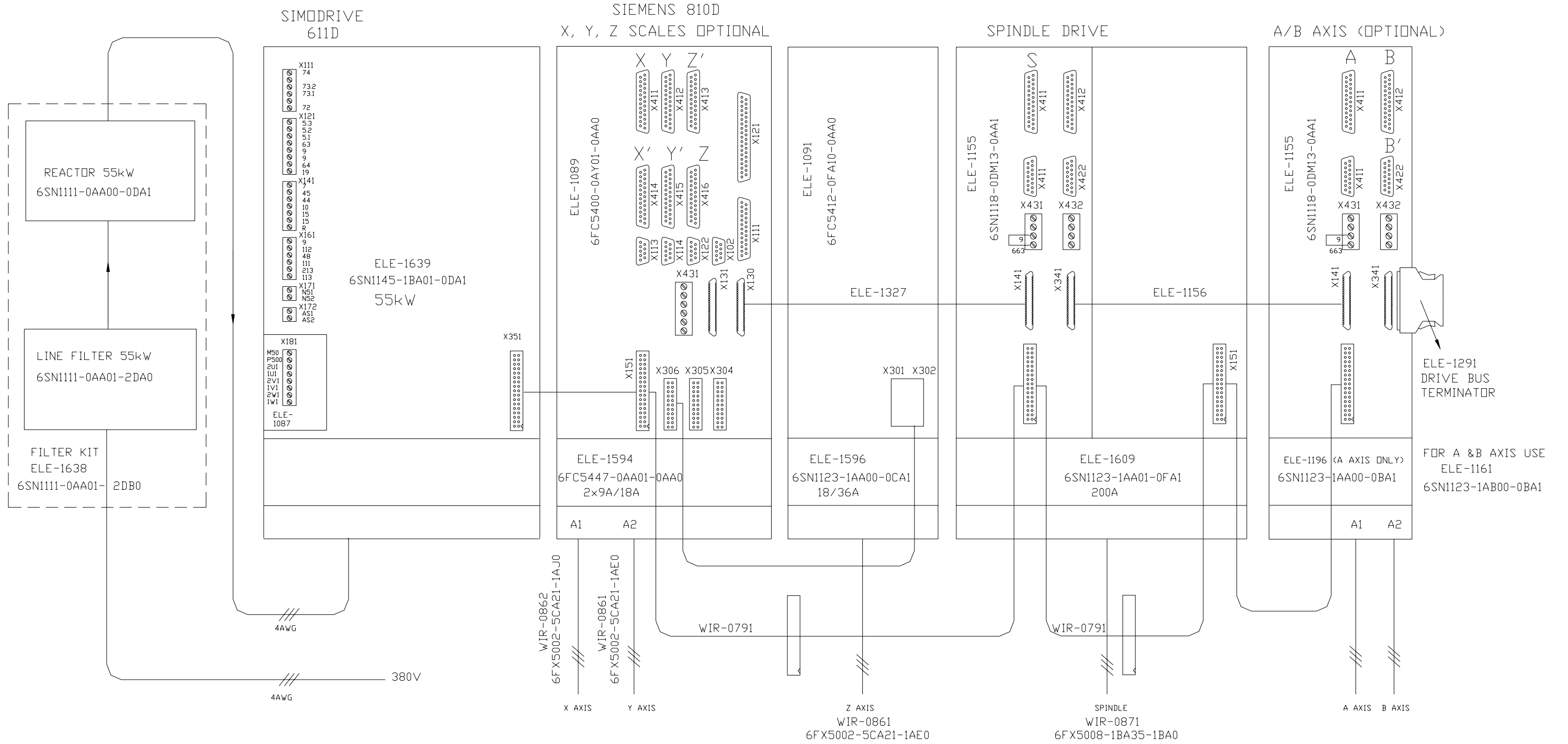

- NOTE: - X, Y, Z AXES MOTOR - MTR-0224 1FT6086-8AC71-1AG0
 - SPINDLE MOTOR - MTR-0225 1PH7167-2ND03-0DB0
 - Y, Z AXES SIGNAL CABLE - WIR-0741 6FX5002-2CA31-1AE0
 - X AXIS SIGNAL CABLE - WIR-0742 6FX5002-2CA31-1AJ0
 - Y, Z AXES POWER CABLE - WIR-0861 6FX5002-5CA21-1AE0
 - X AXIS POWER CABLE - WIR-0862 6FX5002-2CA21-1AJ0
 - A AXIS (VH65) - ROT-0431
 - A/B AXIS (TR65) - ROT-0436
 - MAIN POWER DISCONNECT 100A - ELE-1600

Wrg_0067_6535_40tap_siemens810_std

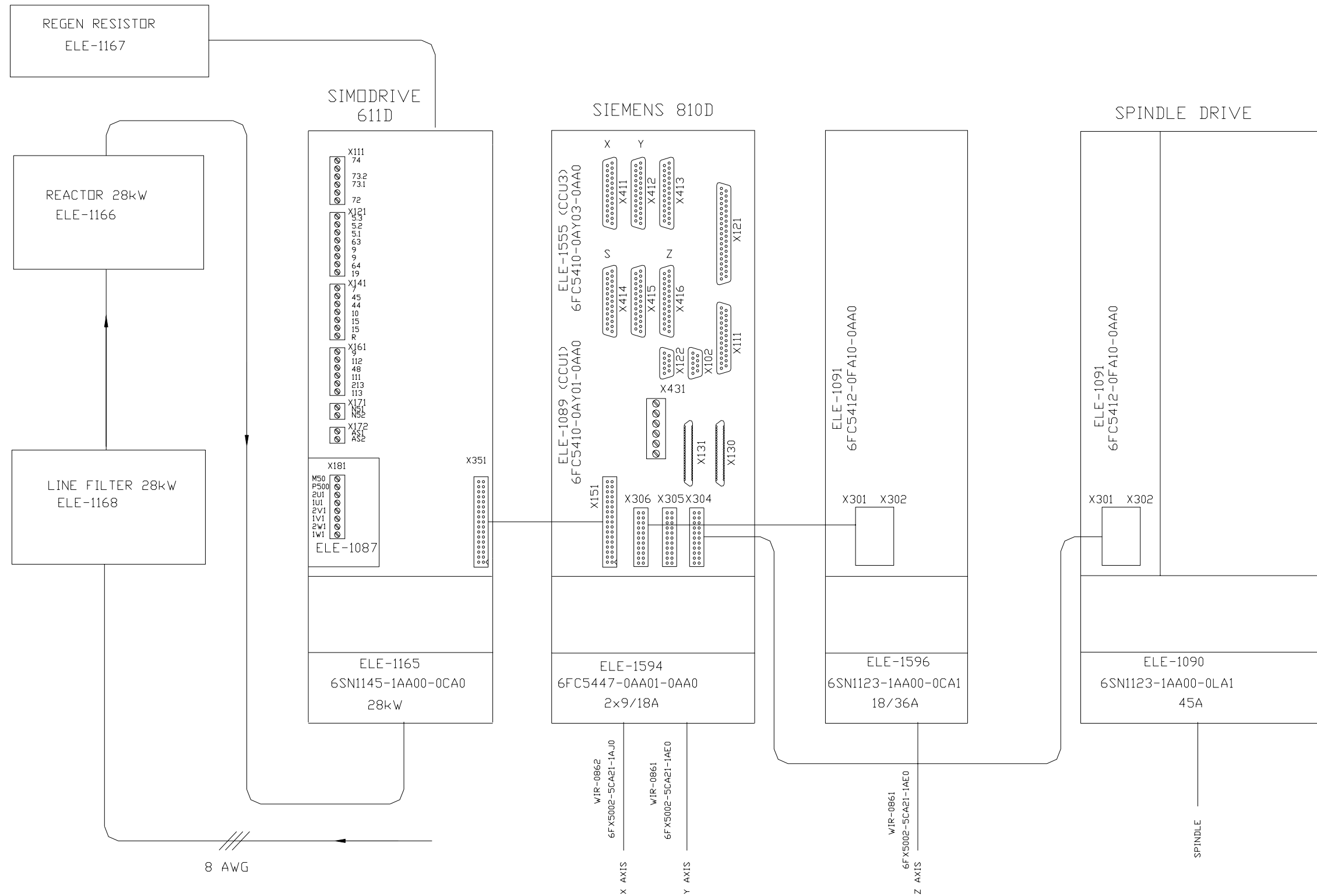

NOTE: -X, Y, Z AXES MOTOR - MTR-0224 1FT6086-8AC71-1AG0
 -Y, Z AXES SIGNAL CABLE - WIR-0741 6FX5002-2CA31-1AE0
 -X AXIS SIGNAL CABLE - WIR-0742 6FX5002-2CA31-1AJ0
 -Y, Z AXES POWER CABLE - WIR-0861 6FX5002-5CA21-1AE0
 -X AXIS POWER CABLE - WIR-0862 6FX5002-2CA21-1AJ0
 - FOR VHT USE ELE-1164 SPINDLE POWER SECTION

Wrg_0068A_atc_wiring

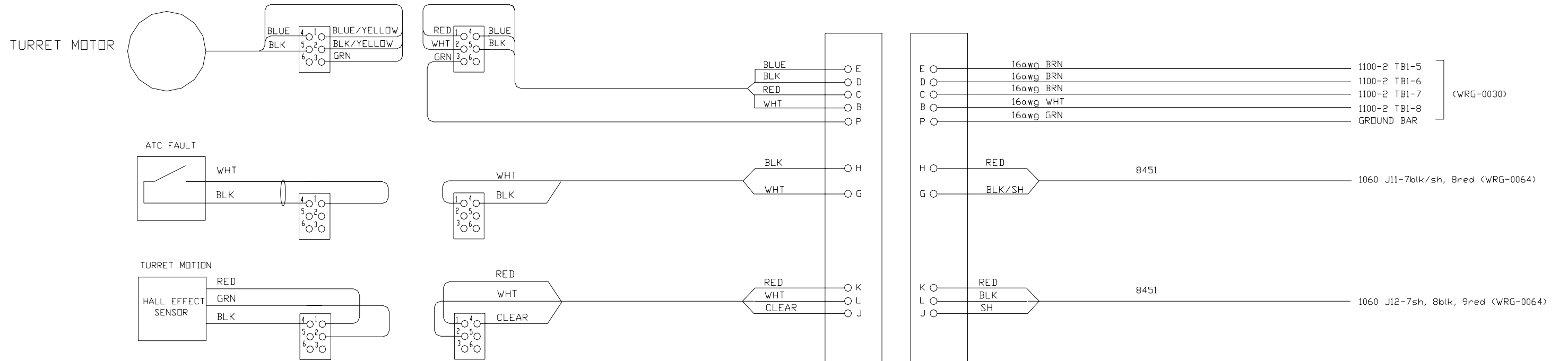
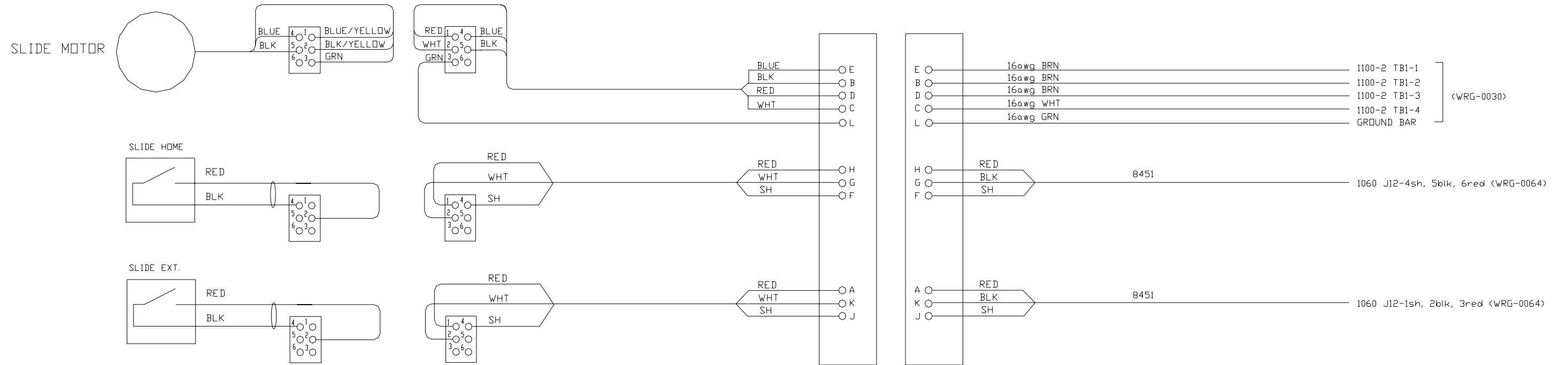

SECTION 8

Siemens

WRG_0002H_siemens_control_1of5

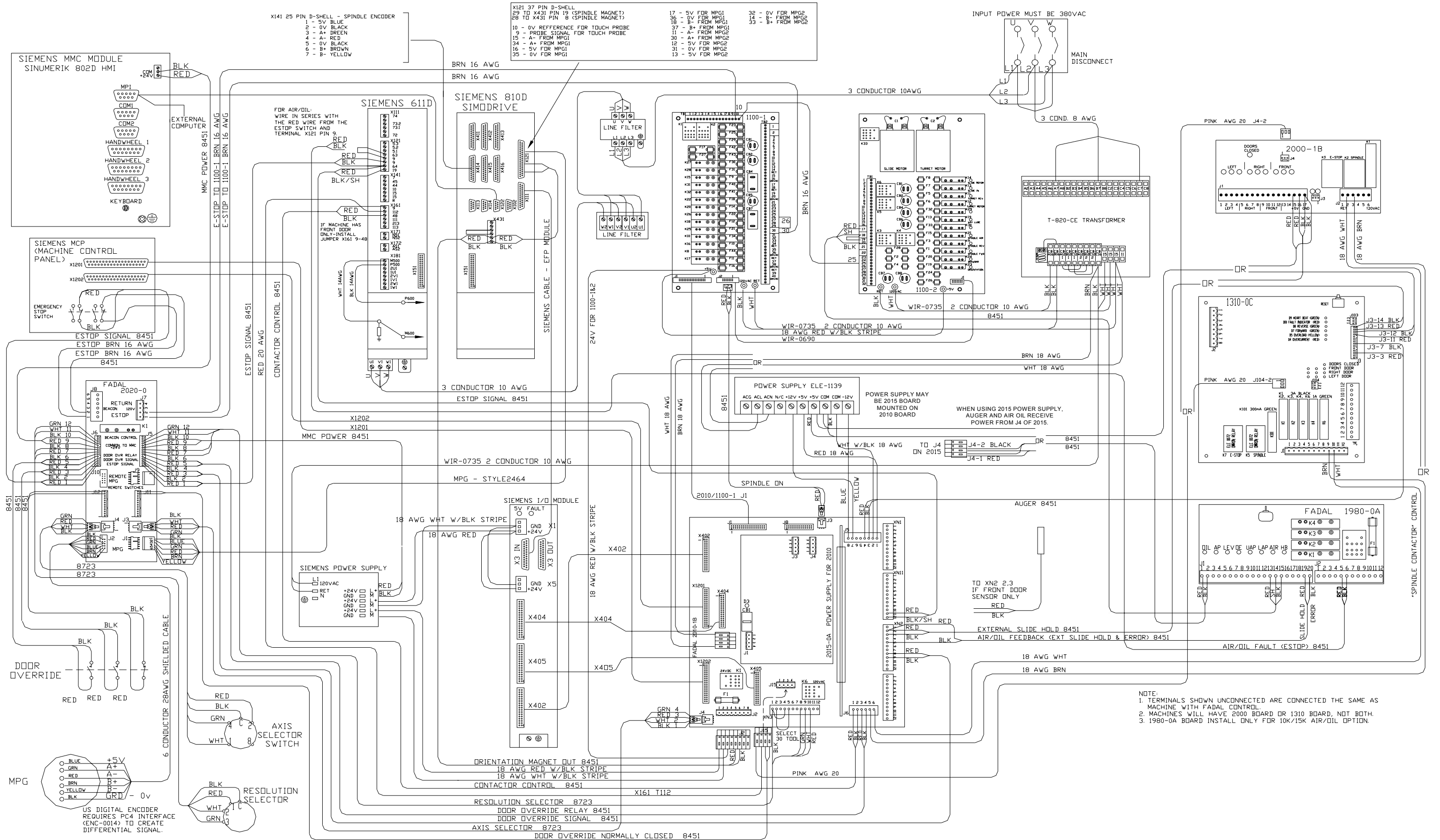

WRG_0002H_siemens_control_3of5

OPT-0186 VMC 3020
OPT-0233 VMC 4525

① STANDARD (NO SCALE)

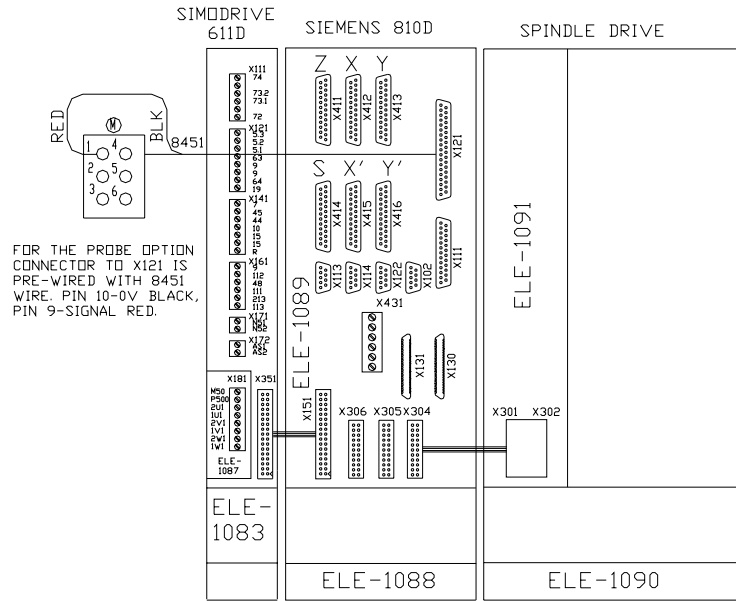

OPT-
② X, Y, SCALES FOR SIEMENS

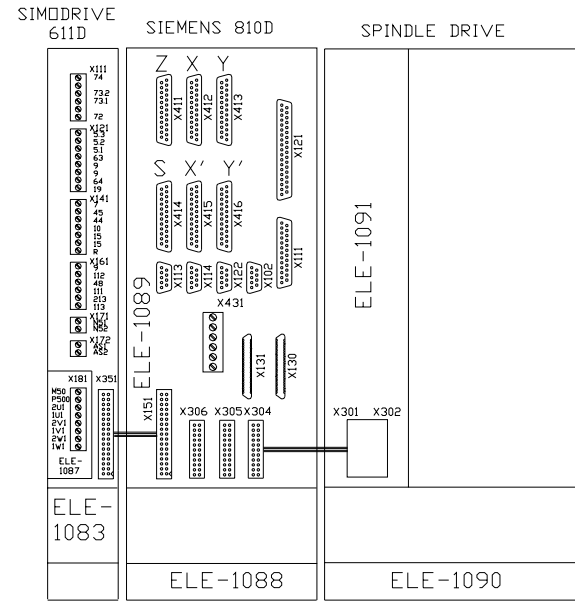

OPT-0197
③ X,Y,Z SCALES FOR SIEMENS

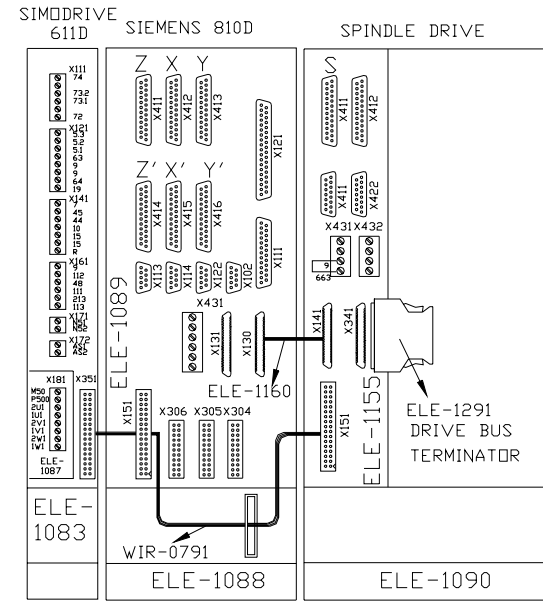

OPT-0199
④ A AXIS FOR SIEMENS

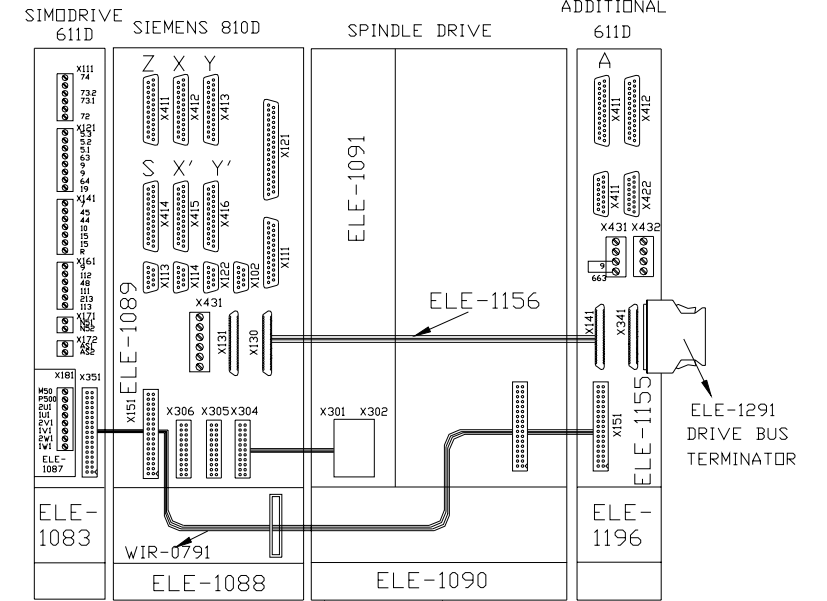

OPT-0197 & OPT-0199
⑤ A AXIS & X, Y, Z SCALE FOR SIEMENS

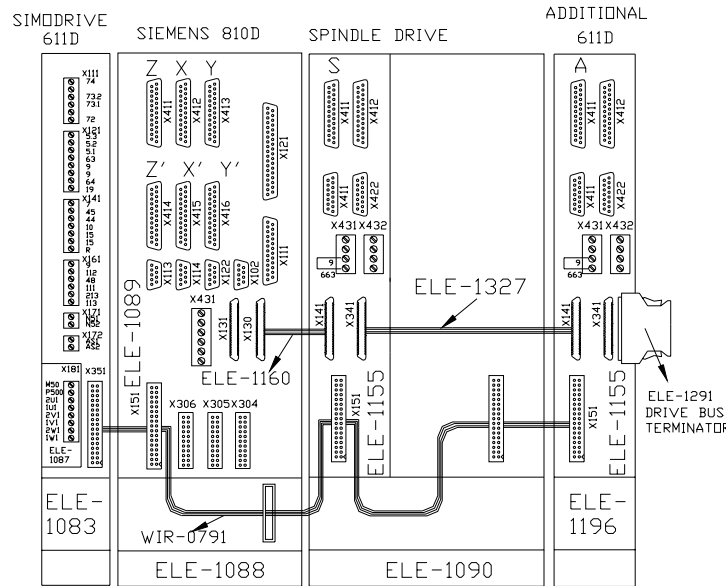

OPT-0200
⑥ A&B AXIS FOR SIEMENS

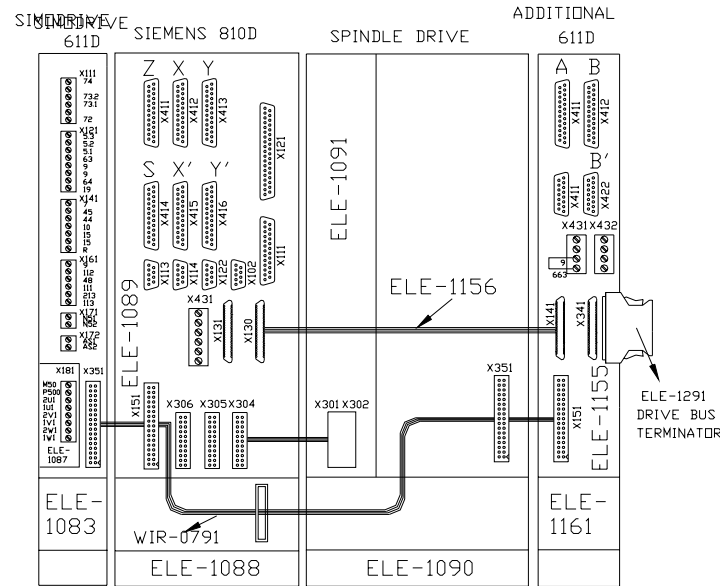

OPT-0197 & OPT-0200
⑦ A/B AXIS & X, Y, Z SCALE FOR SIEMENS

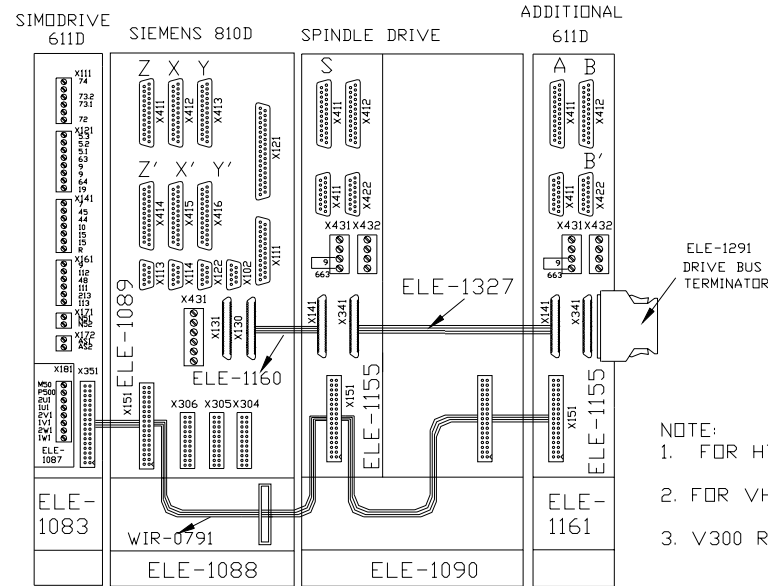

- NOTE:
- FOR HT - USE I/R MODULE SIMODRIVE 611D (16KW) ELE-1083, SPINDLE DRIVE 45 AMP ELE-1090
 - FOR VHT - USE U/E MODULE SIMODRIVE 611D (28KW) ELE-1165, SPINDLE DRIVE 60 AMP ELE-1164
 - V300 ROTARY TABLE - USE ELE-1242 CONTROL MODULE.

WRG_0002H_siemens_control_4of5_electrical

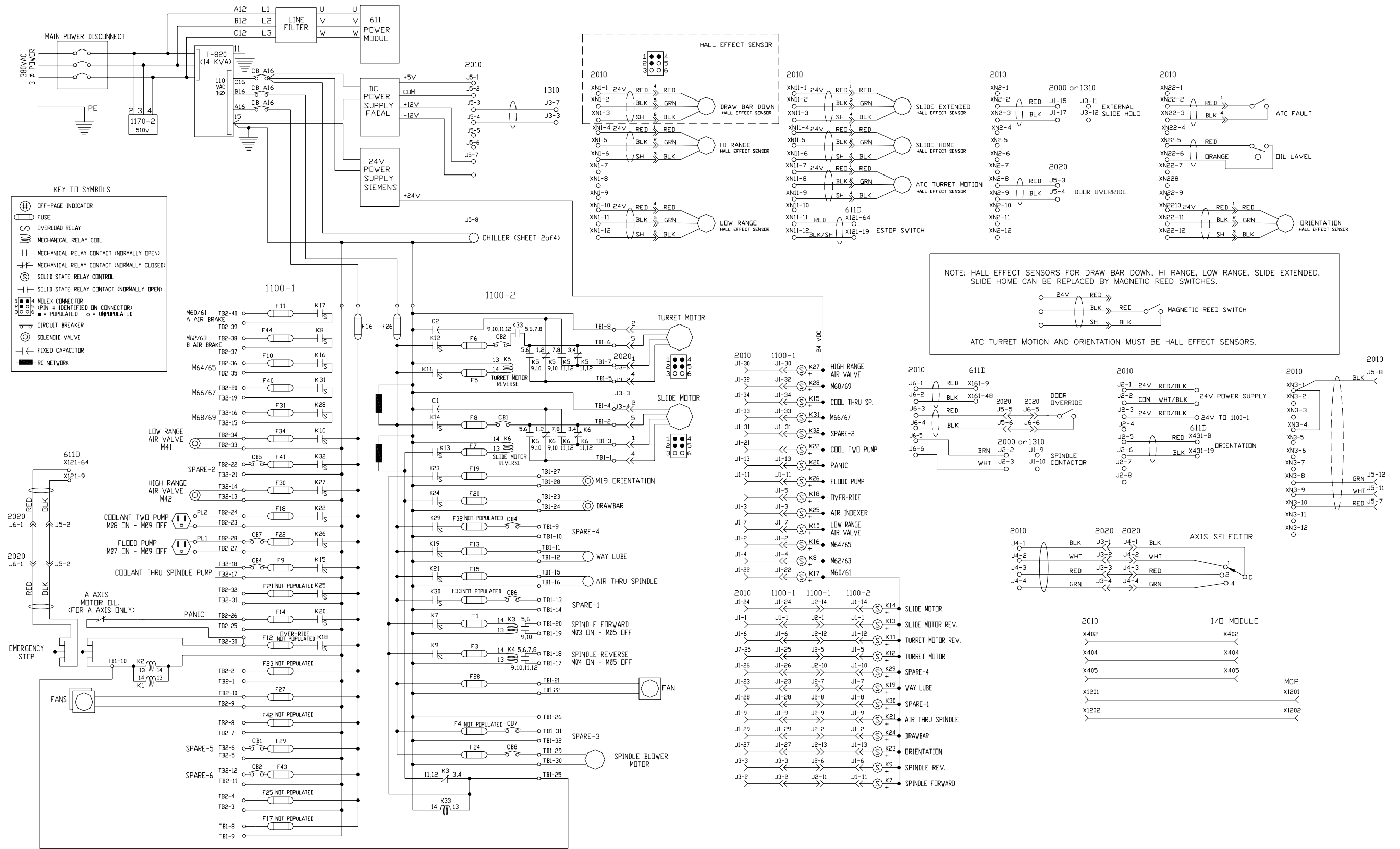

Wir_0019C_scale_cable_siemens

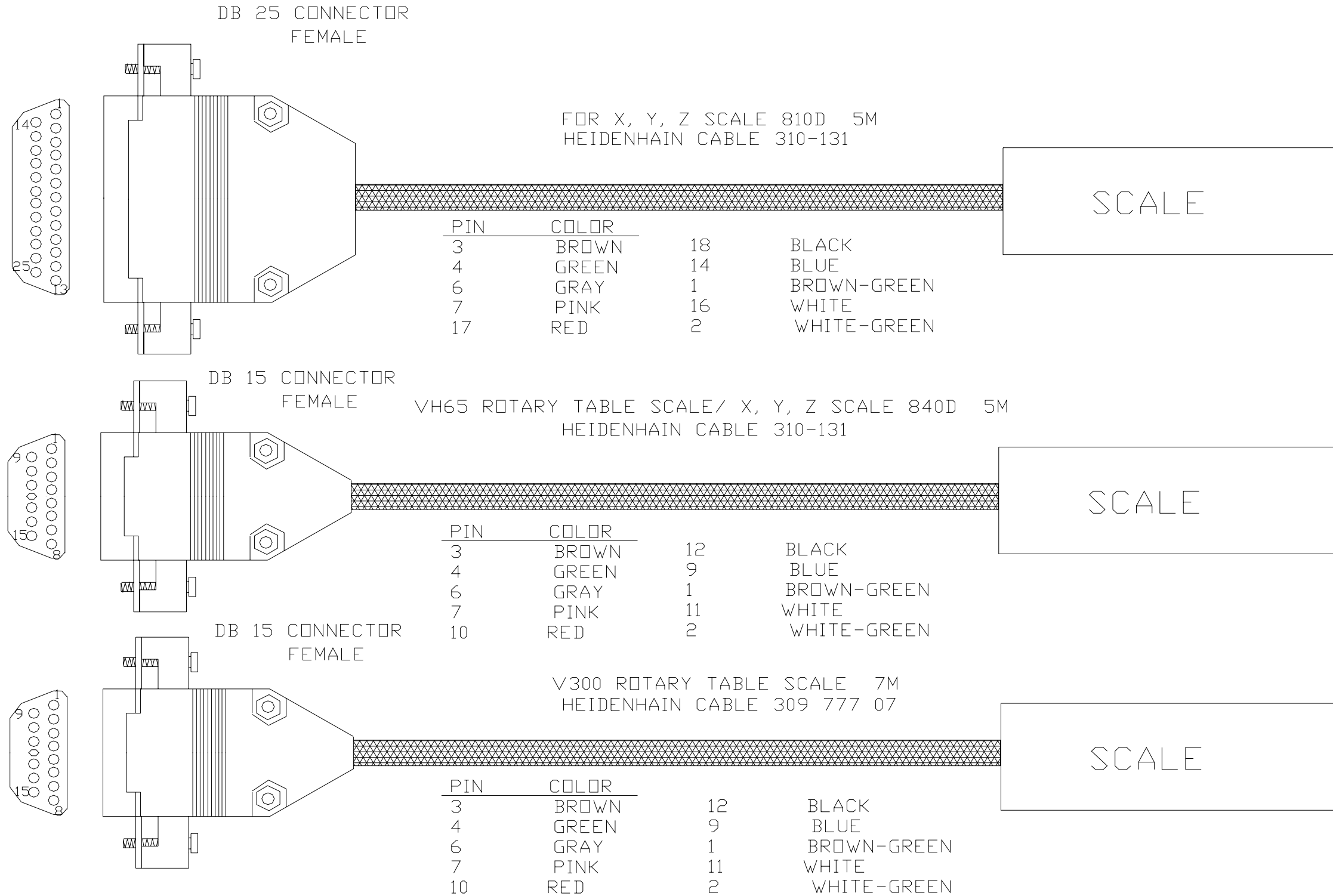

NOTE: OUTER SHIELD CONNECTED
TO CONNECTOR HOUSING
FOR ALL CABLES

Wrg_0031A_mp12_probe_siemens

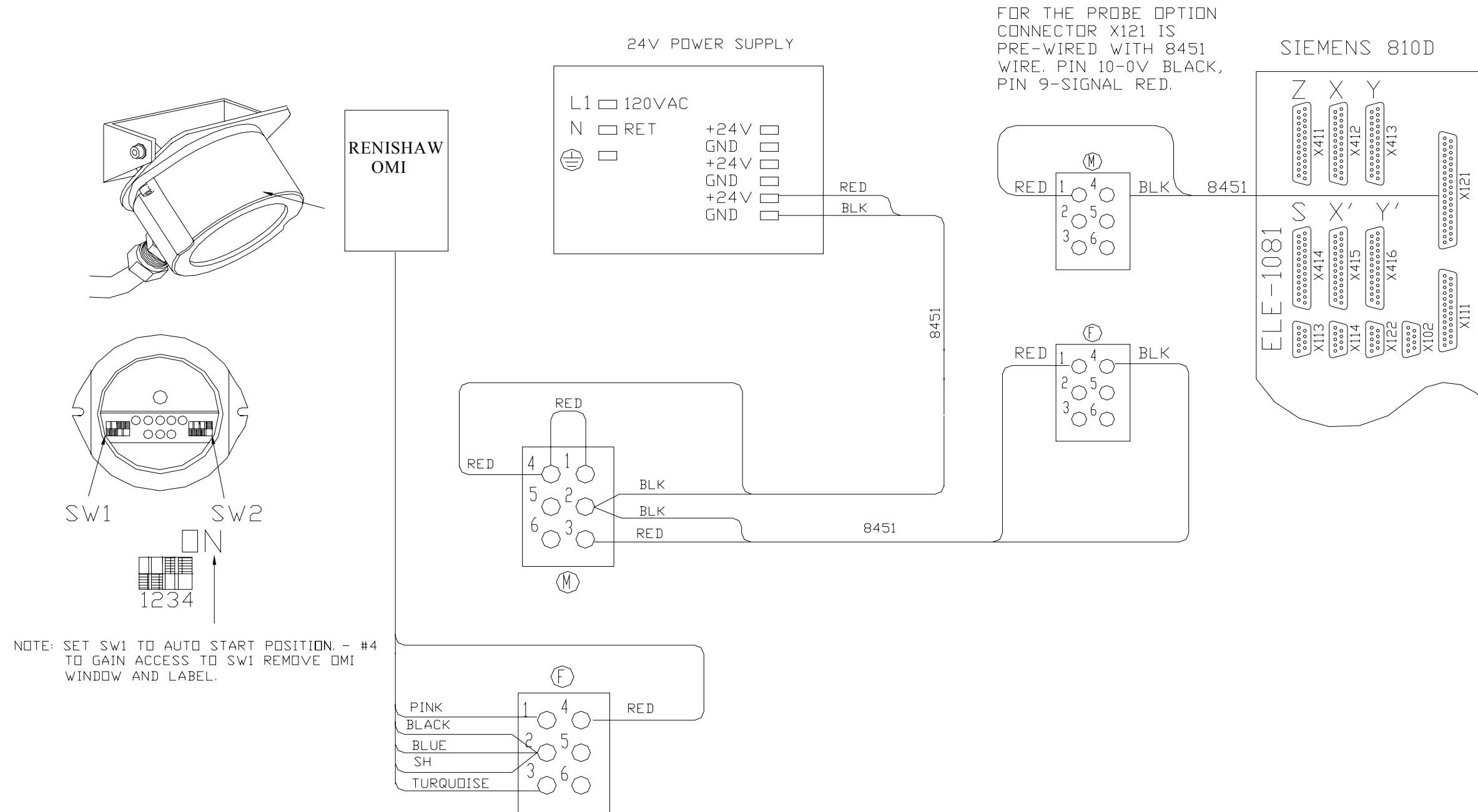

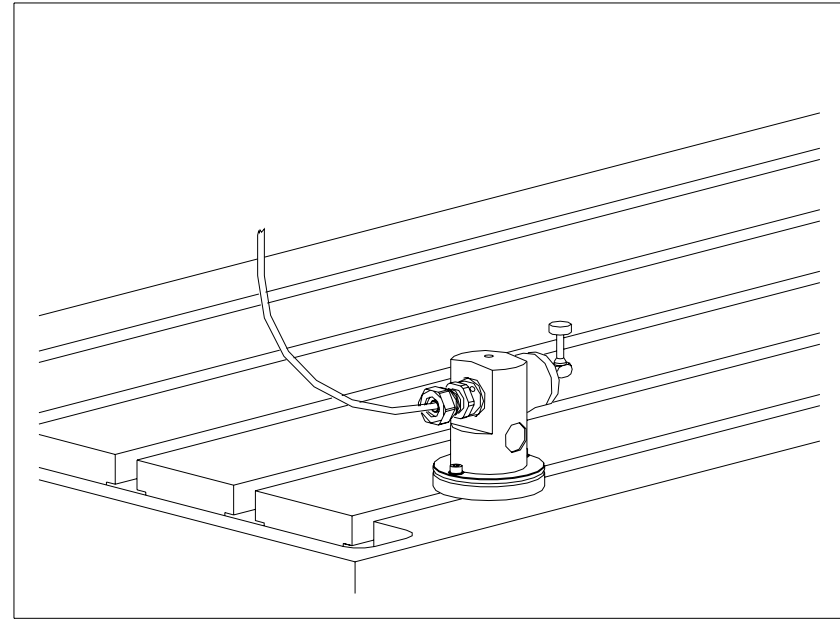

FOR THE PROBE OPTION
CONNECTOR X121 IS
PRE-WIRED WITH 8451
WIRE. PIN 10-0V BLACK,
PIN 9-SIGNAL RED.

SIEMENS 810D

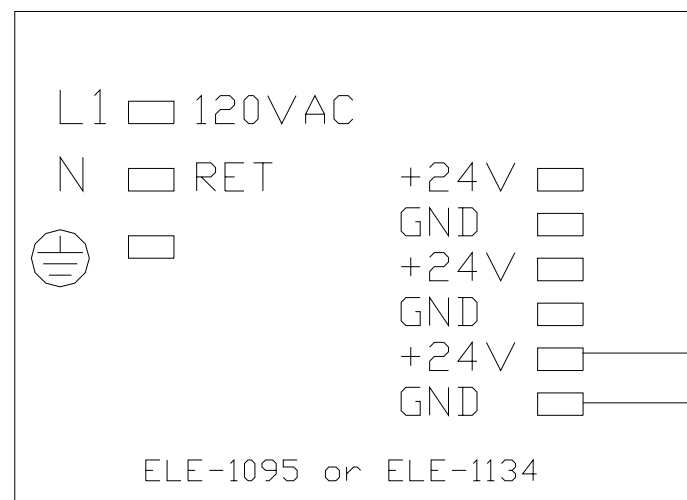
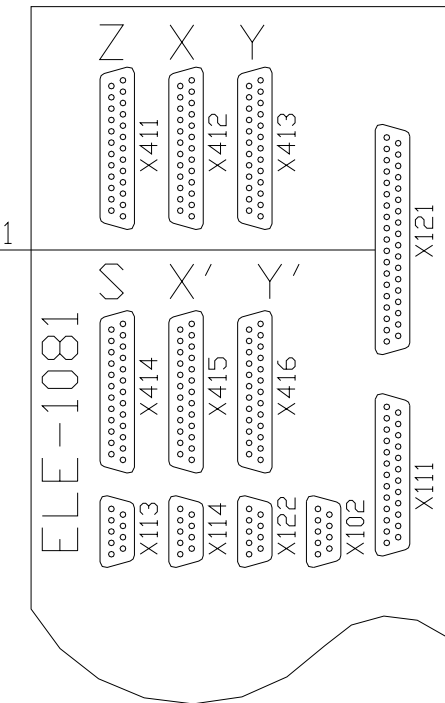
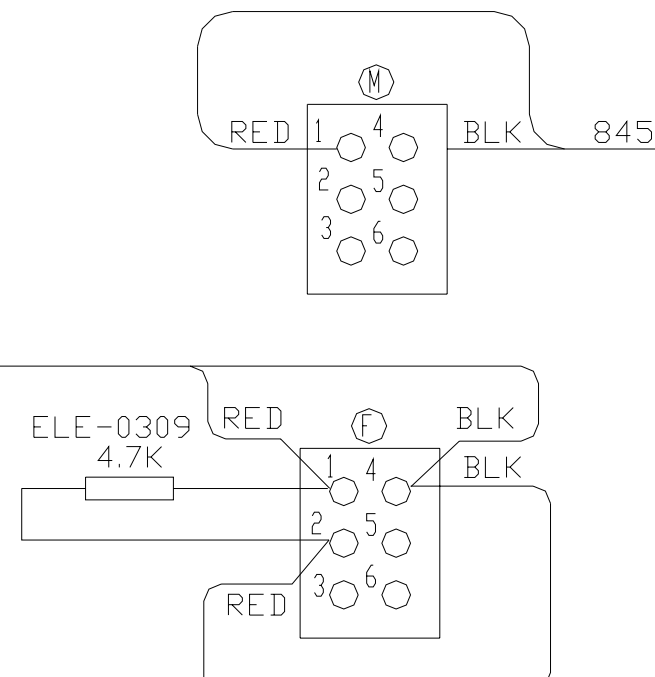

Wrg_0036D_mp12_ts27_combo_siemens

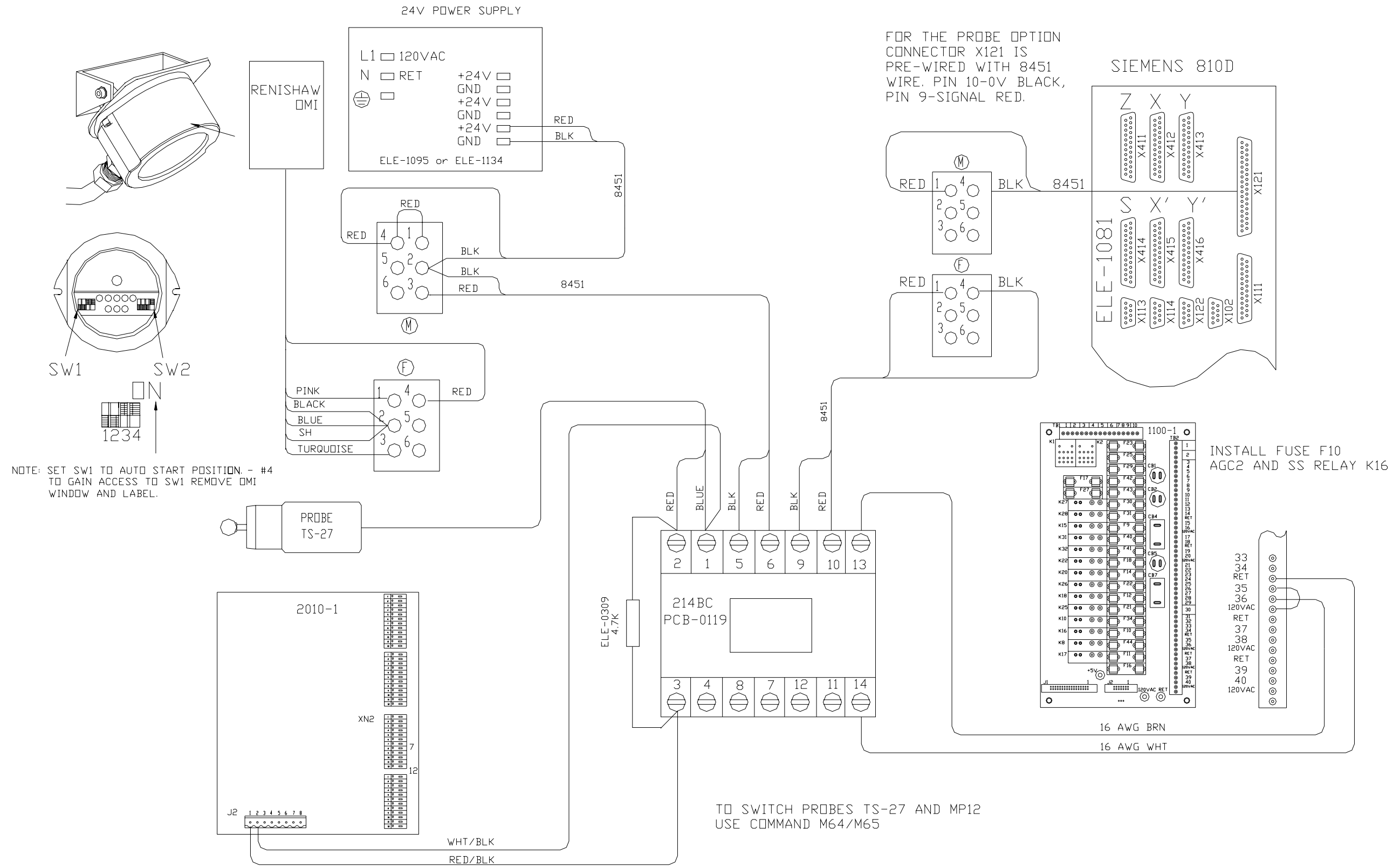

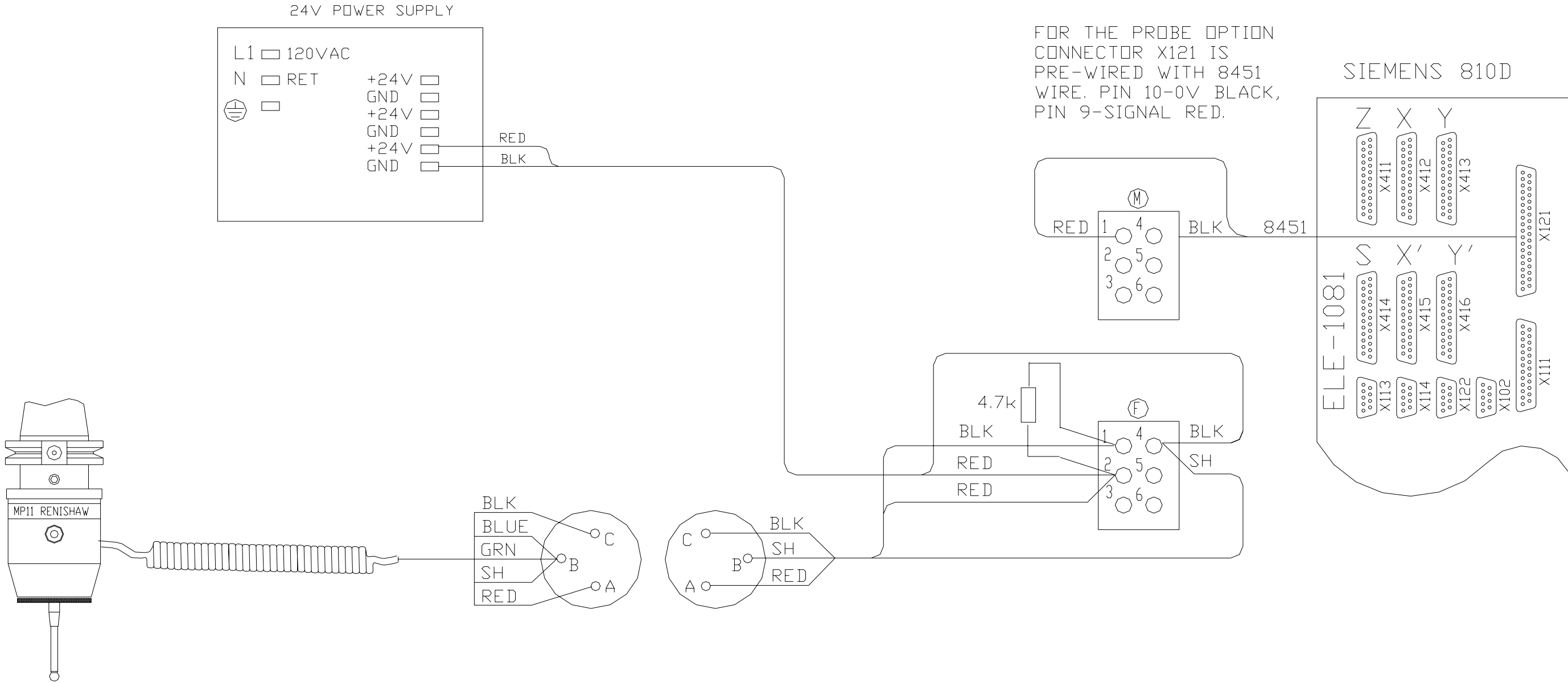

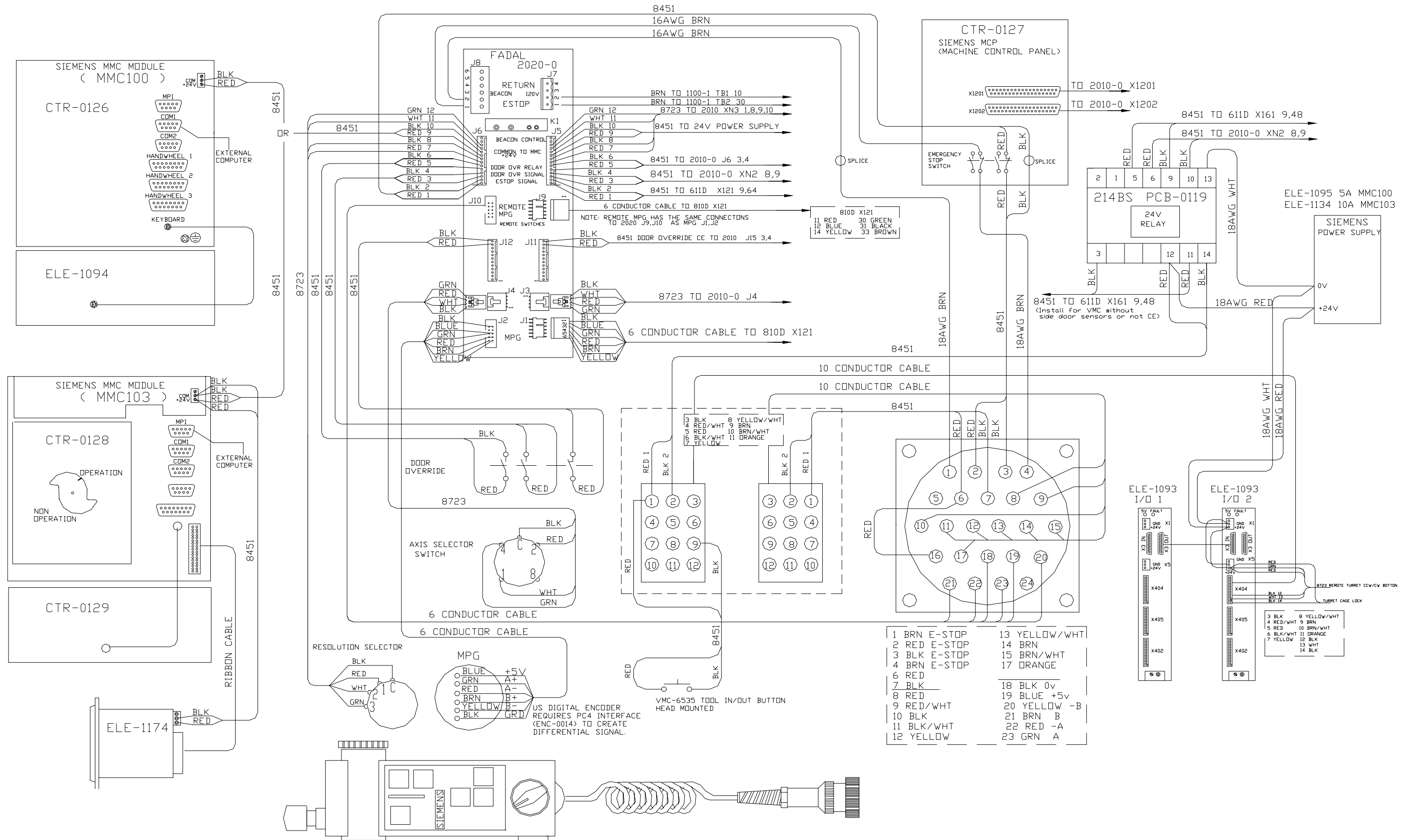

WRG_0060A_Dual_Arm_Tool_Changer_Siemens

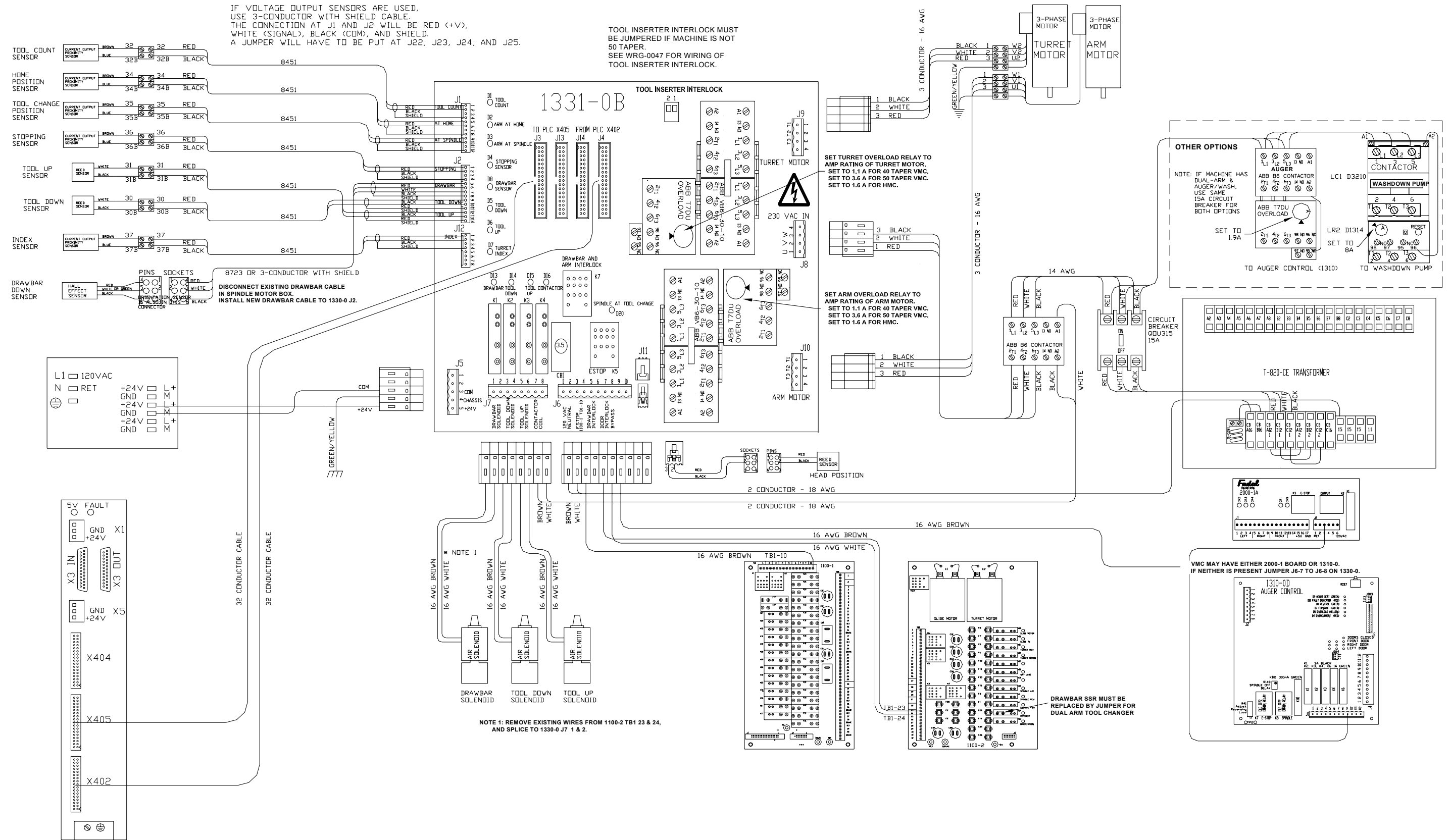

OPT-0266
STANDARD (X, Y, Z SCALE IF REQUIRE)

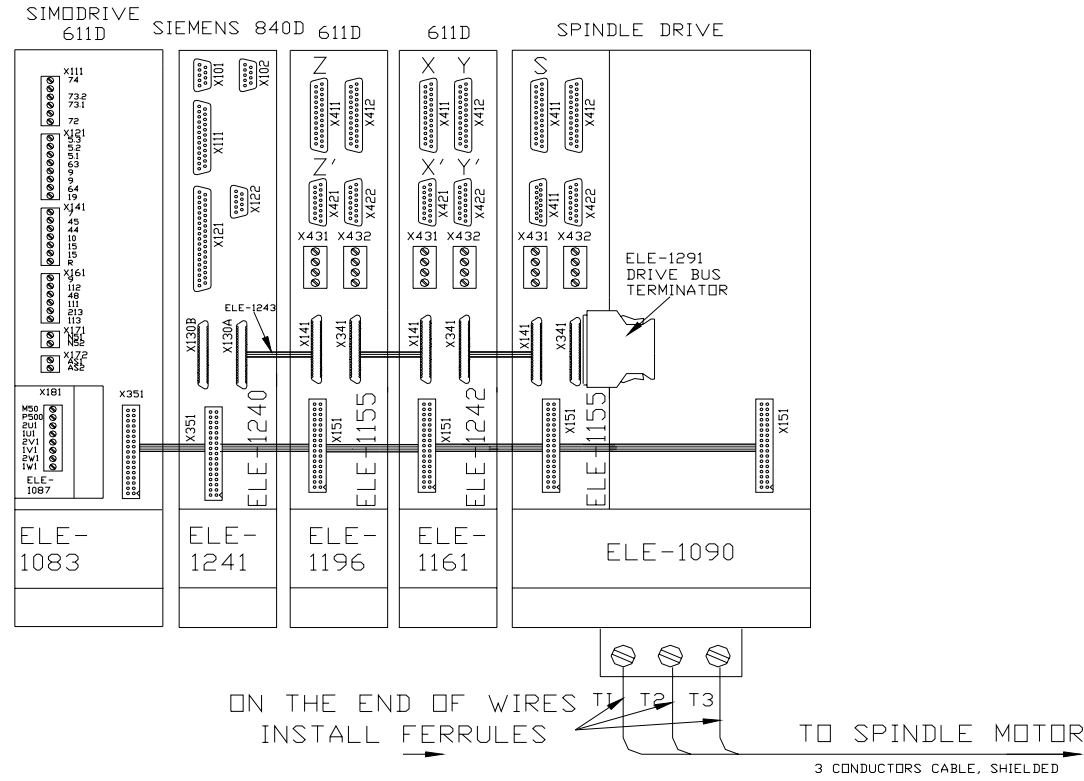

OPT-0267
A AXIS (X, Y, Z SCALE IF REQUIRE)

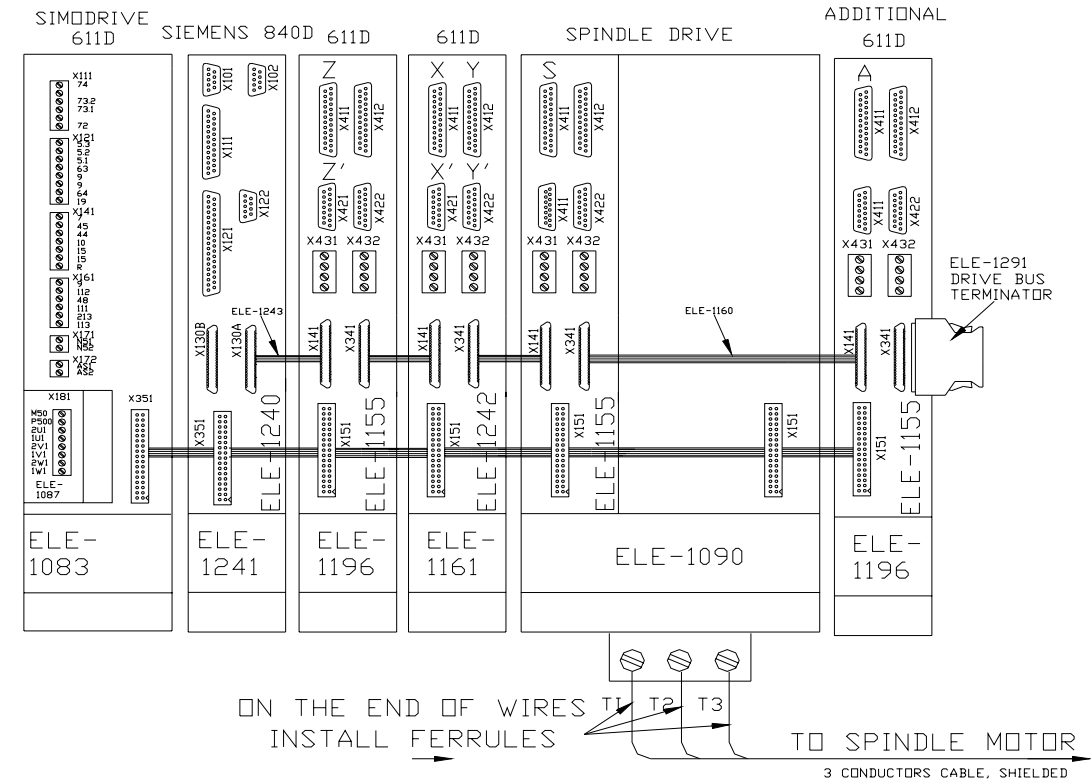

OPT-0268
A&B AXIS (X, Y, Z SCALE IF REQUIRE)

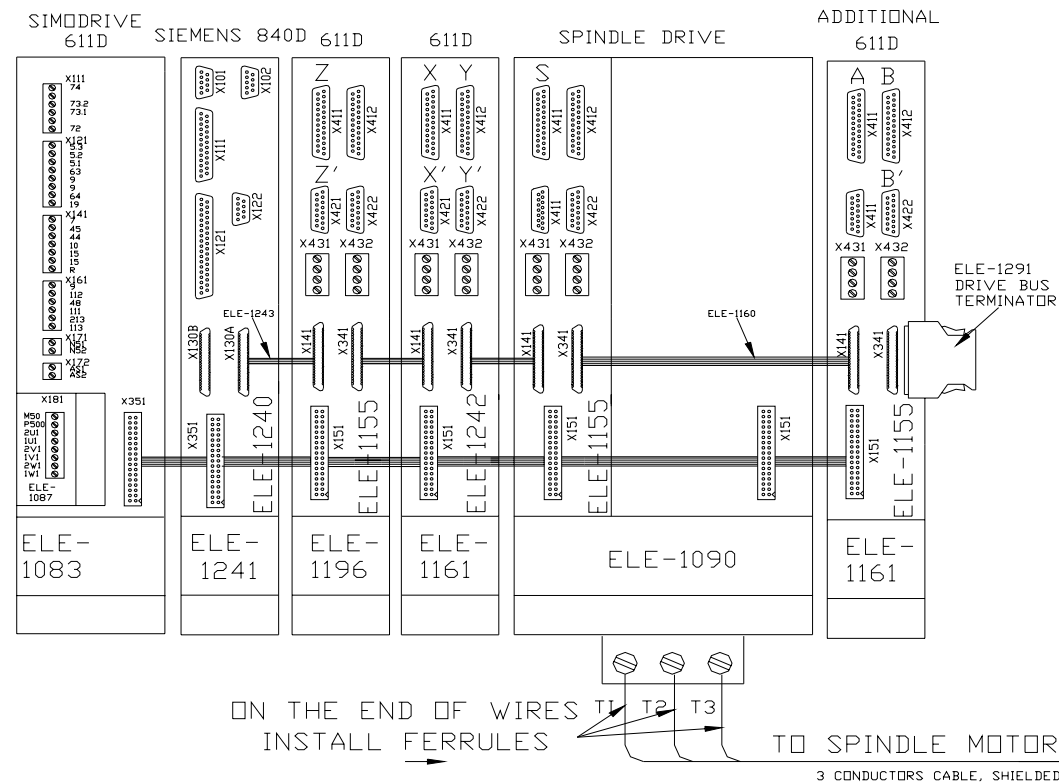

- NOTE: 1. X-X AXIS FEEDBACK
Y-Y AXIS FEEDBACK
Z-Z AXIS FEEDBACK
S-SPINDLE FEEDBACK
X'-X AXIS SCALE
Y'-Y AXIS SCALE
Z'-Z AXIS SCALE
A-A AXIS FEEDBACK
B-B AXIS FEEDBACK
B'-B' AXIS SCALE
2. FOR V300 ROTARY TABLE USE ELE-1242 CONTROL MODULE

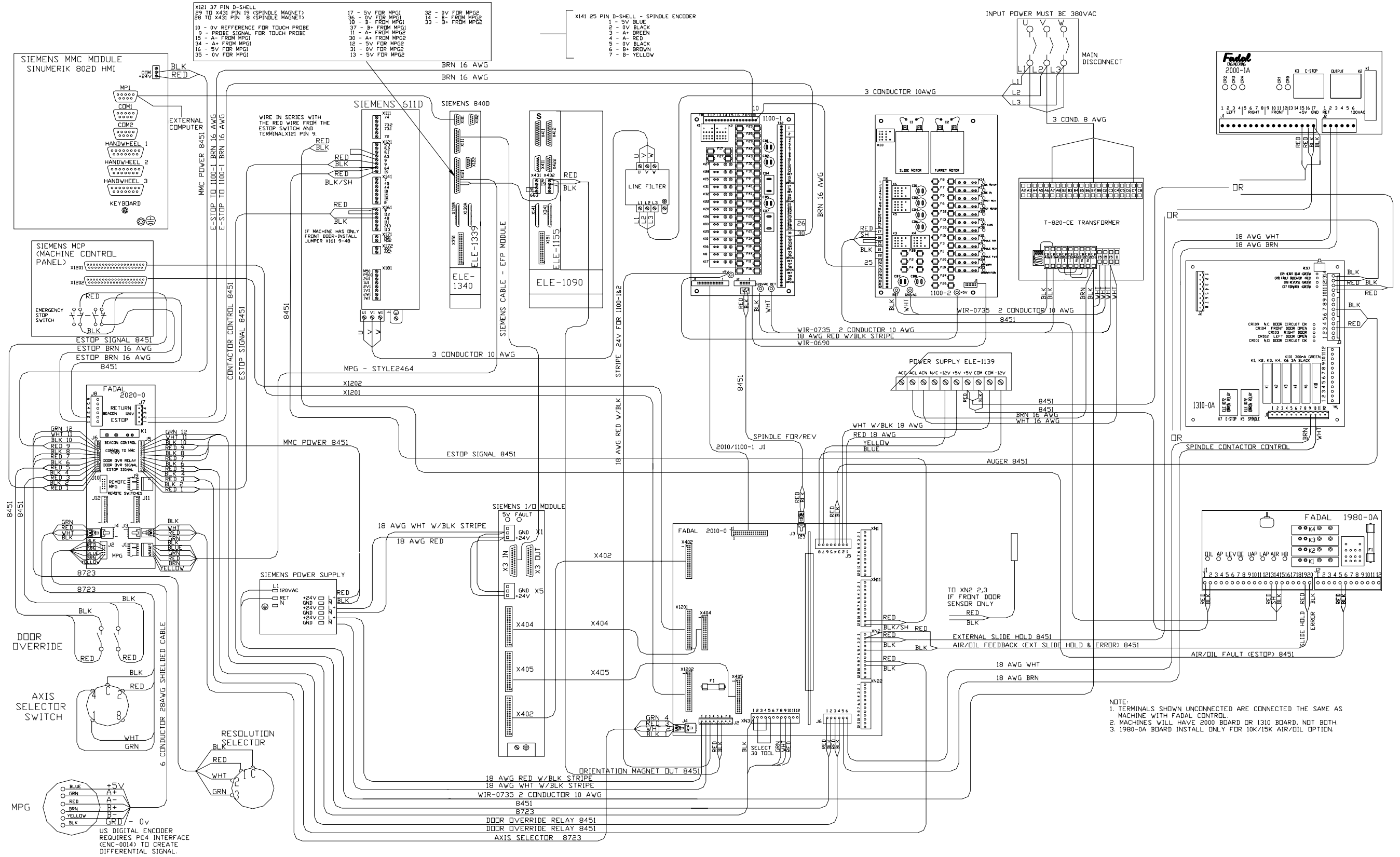

SECTION 9

EMC

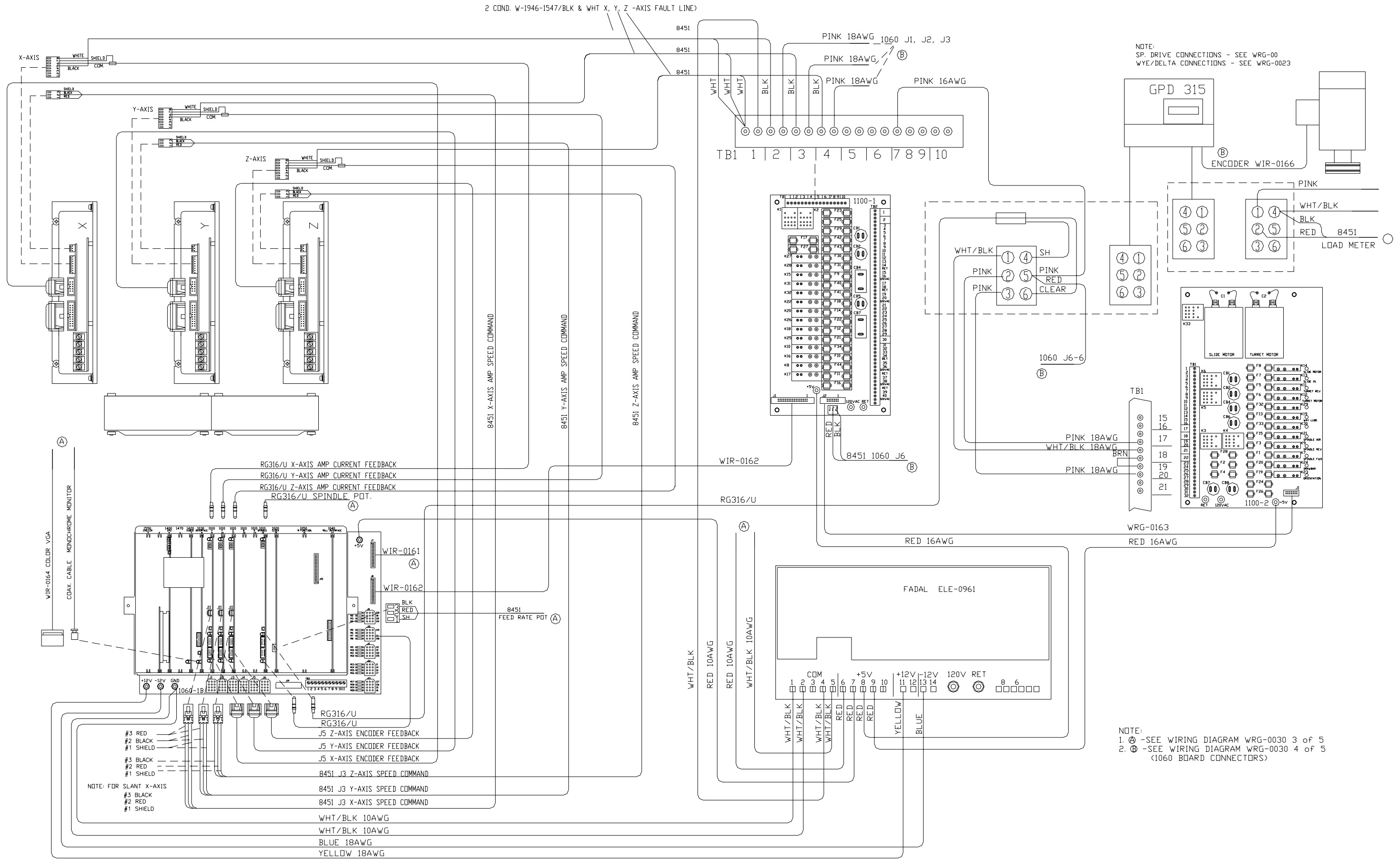

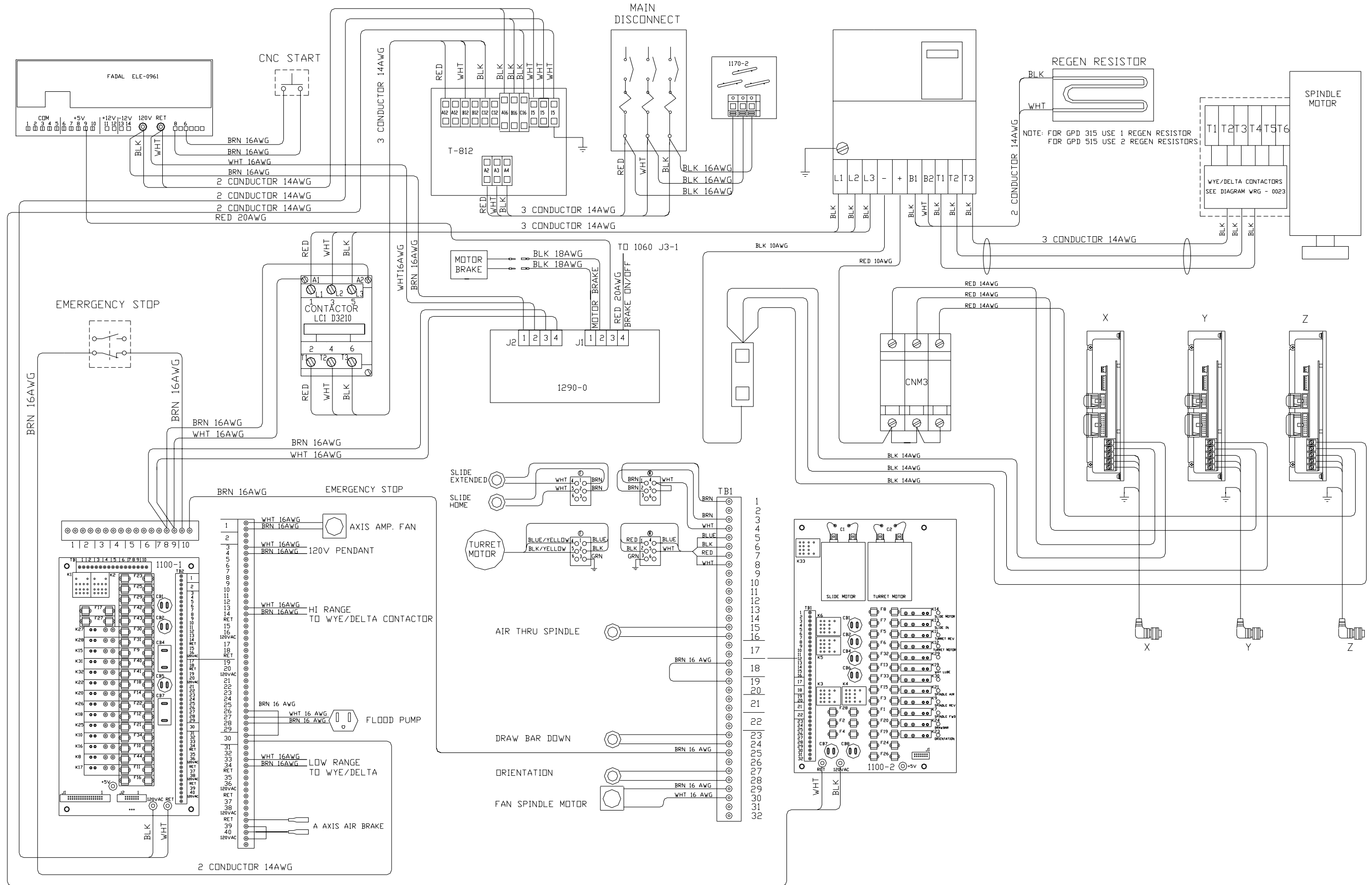

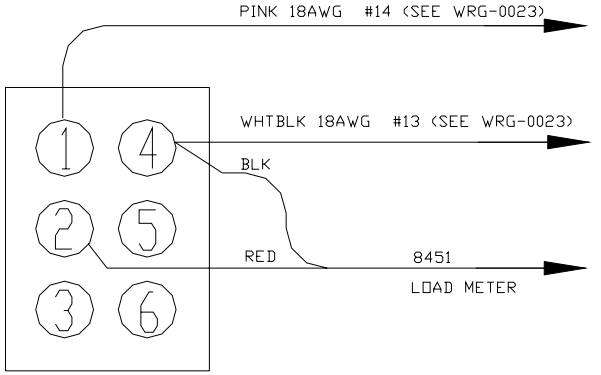
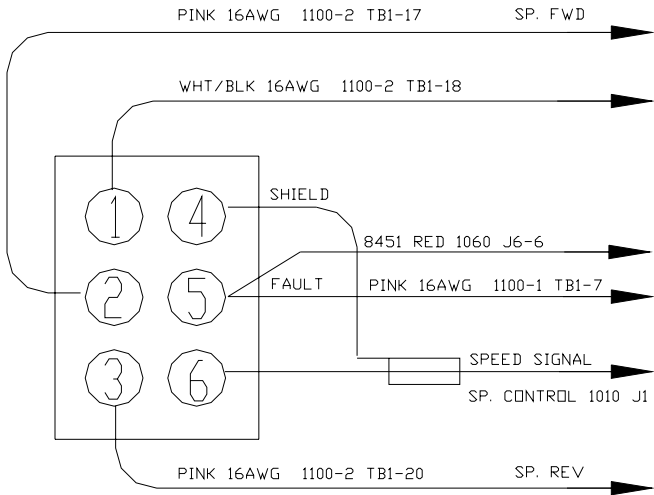
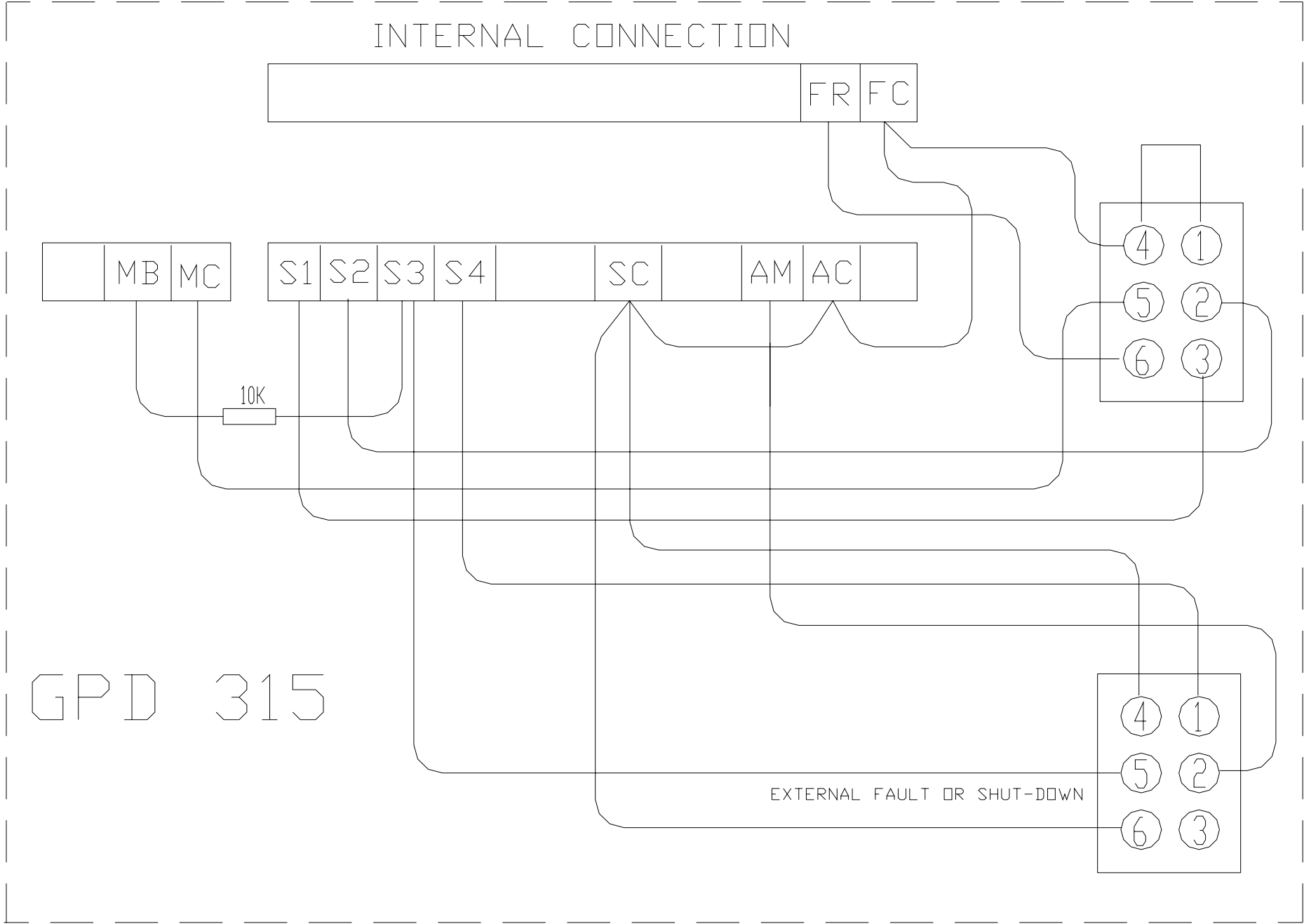

INTERNAL CONNECTION

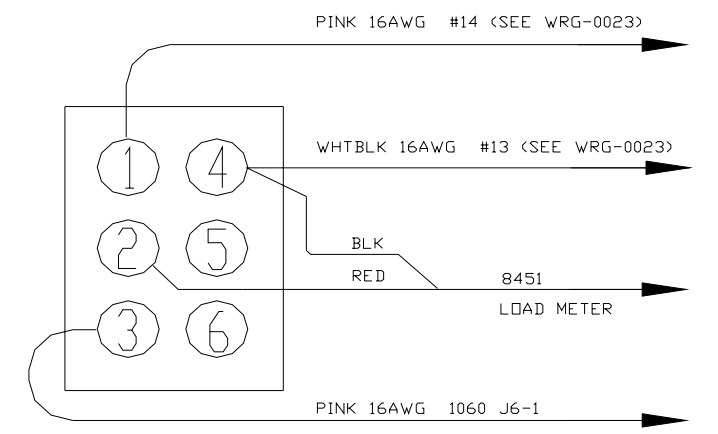
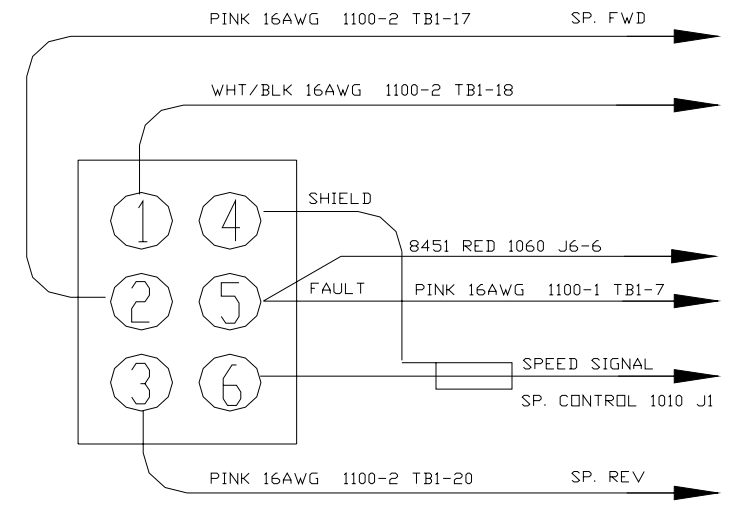
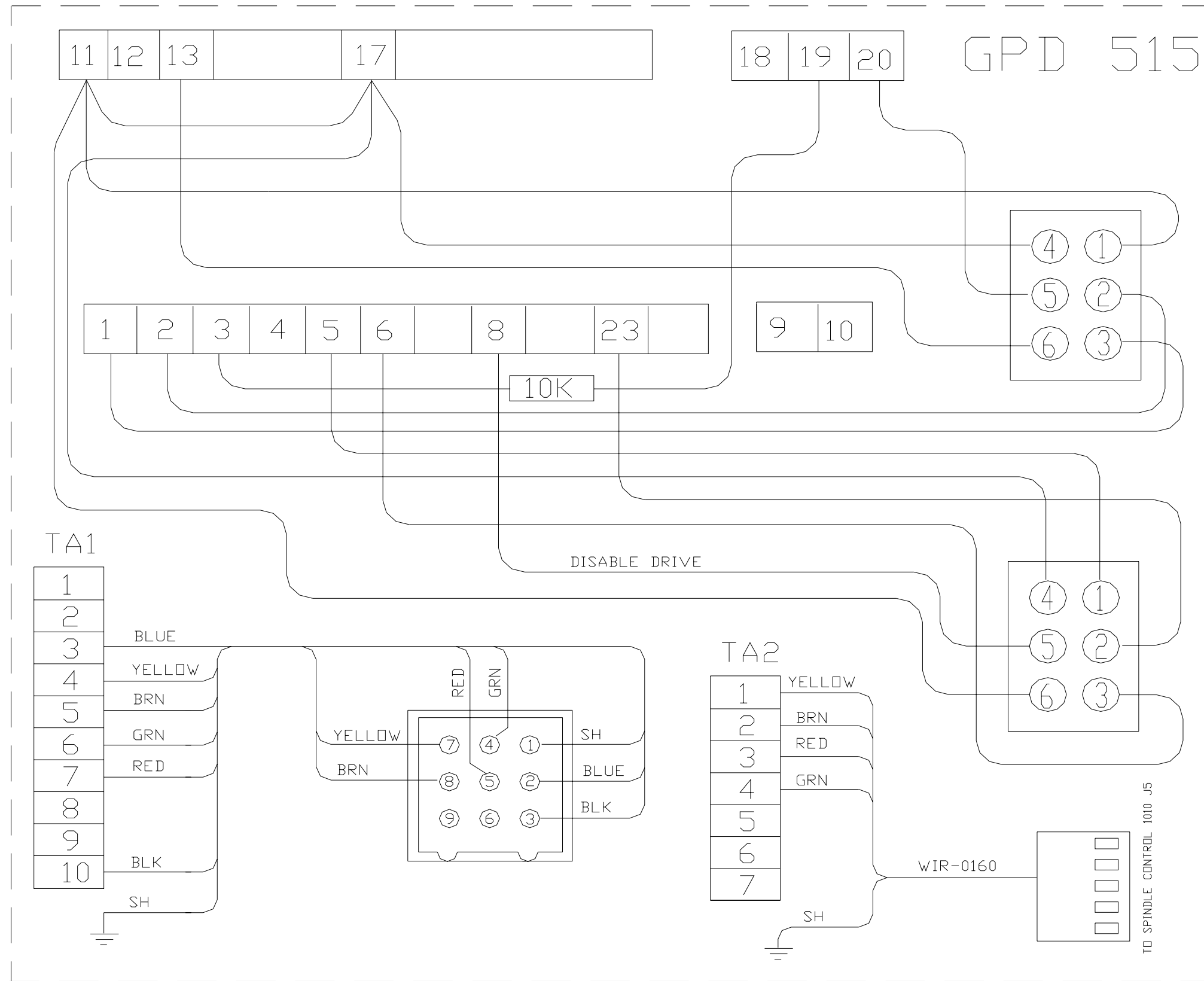

Wrg_0053A_emc_disk_drive_harness

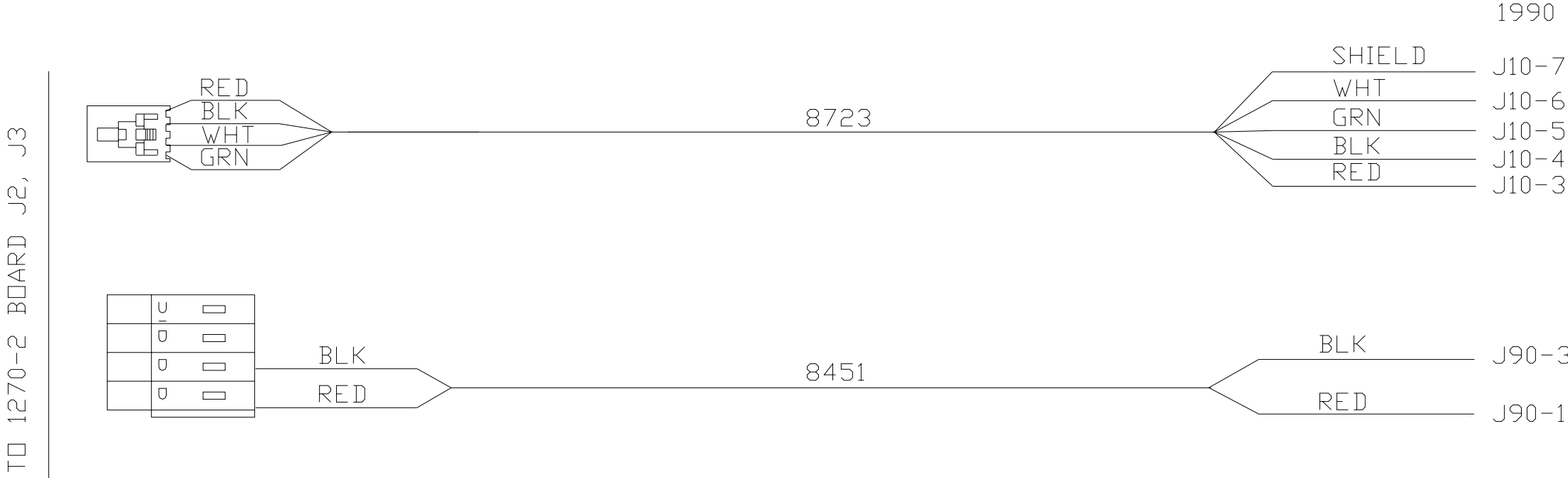

WRG_0041F_ce_door_lock_2030-0A_wiring_diagram_2of3

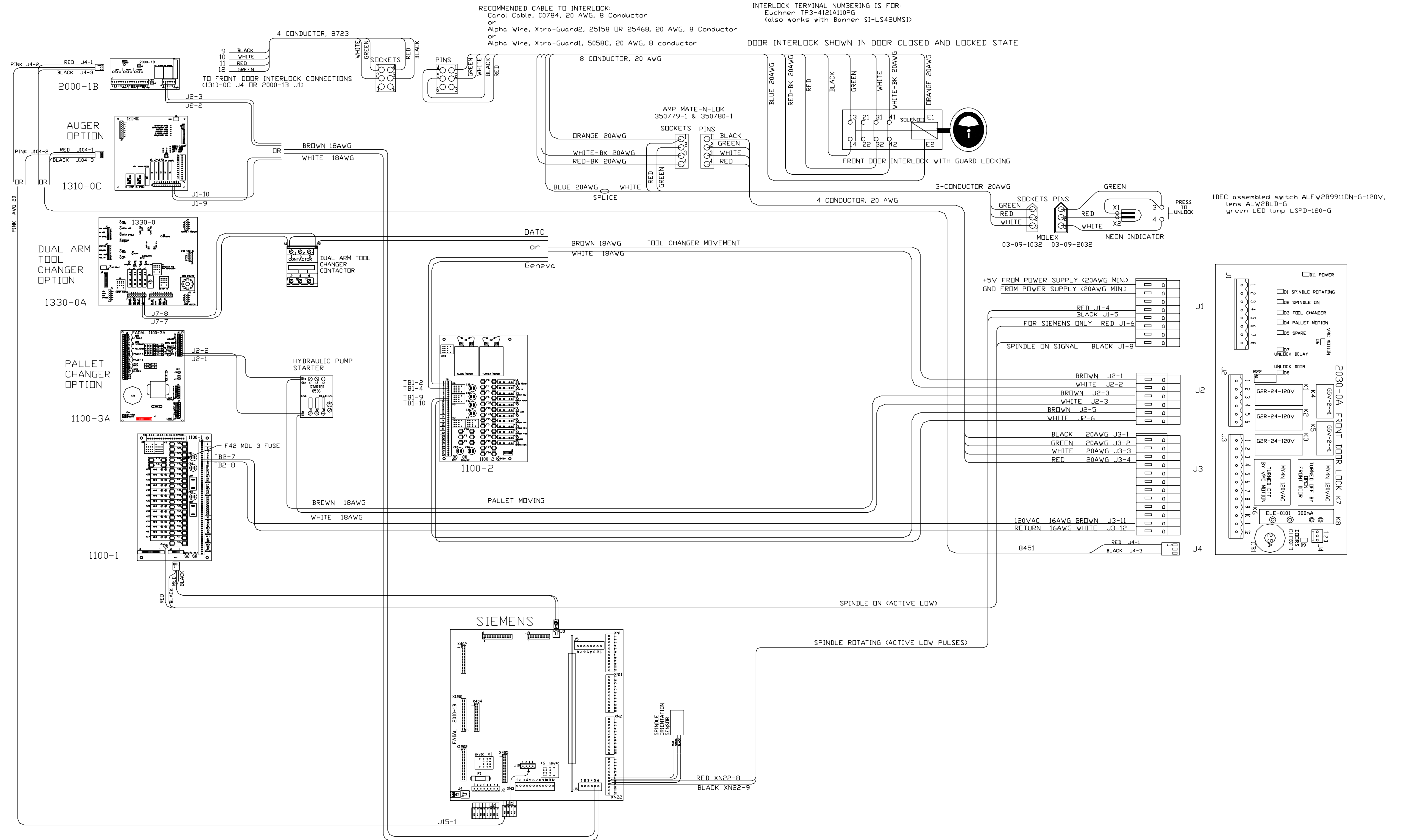

WRG_0041F_ce_door_lock EMC 2030-0A wiring diagram_3of3

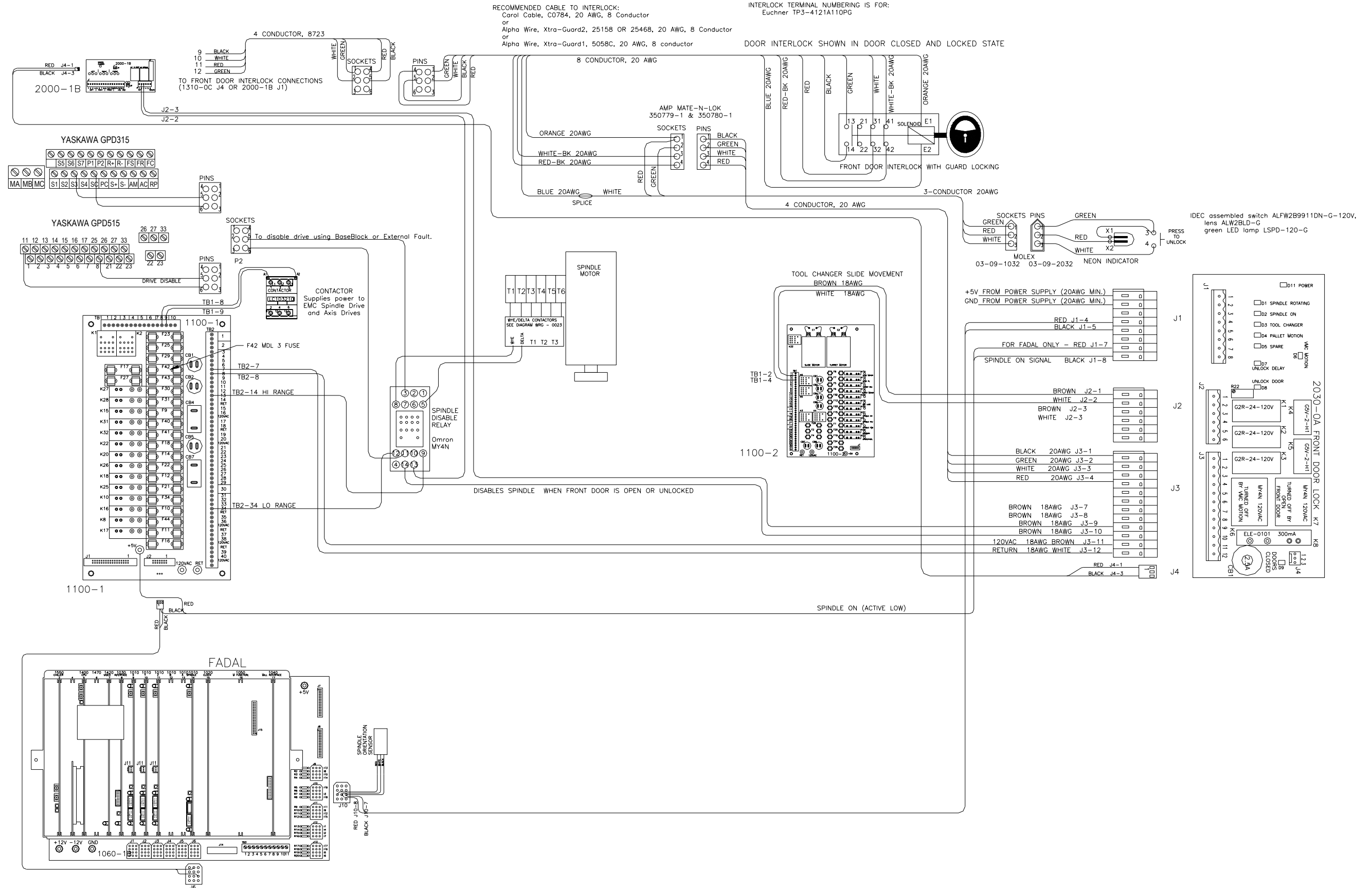

WRG_0049B_emc_4th_axis

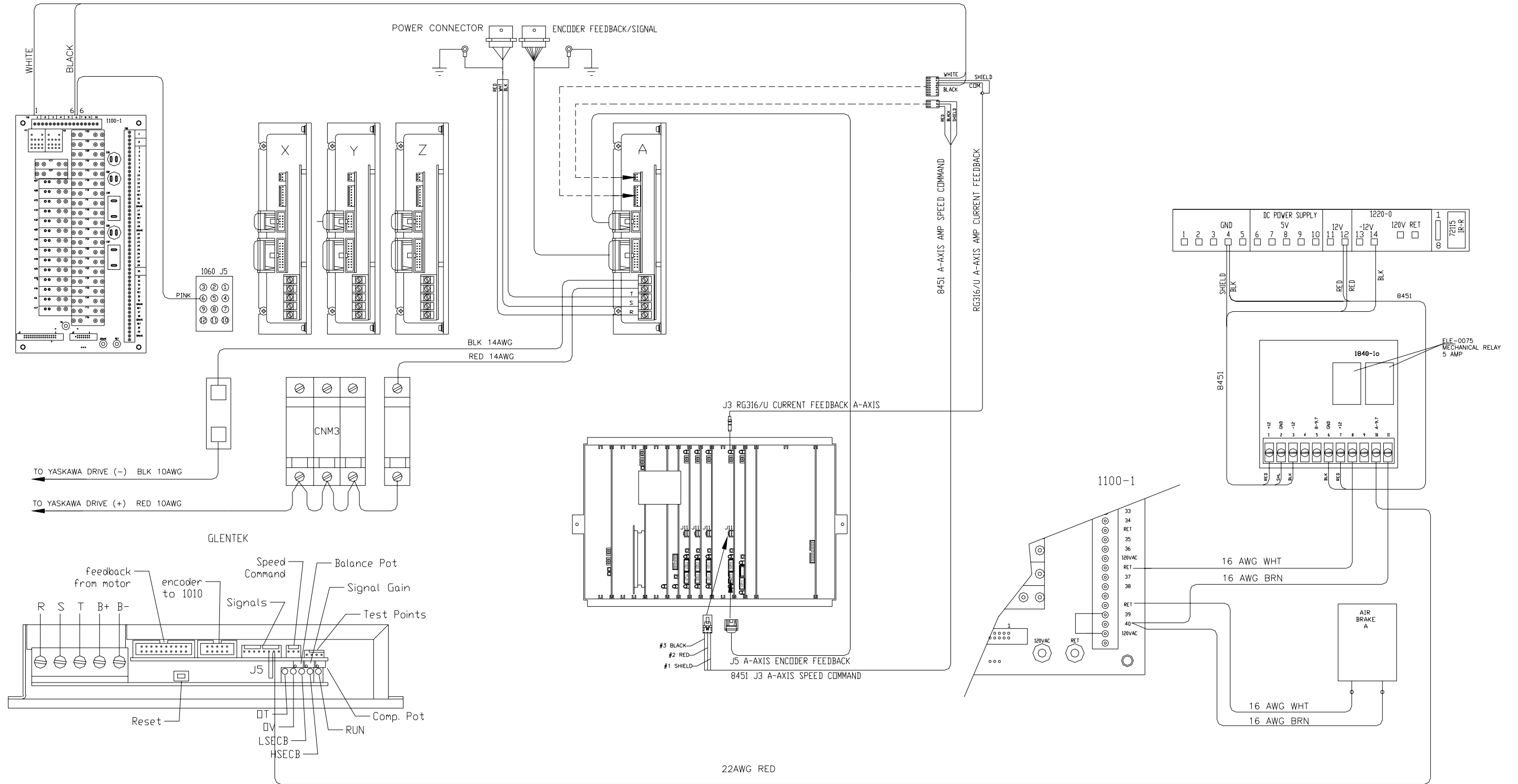

NOTE:

1. INSTALL FUSE F11 (AGC 2) AND SOLID STATE RELAY K17 (GREEN) ON 1100-1 BOARD.
2. USE AMPLIFIER AMP-0029 FOR VH65.
3. INSTALL JUMPER ON 4th AXIS AMPLIFIER IN J5 BETWEEN +LIMIT & -LIMIT (22 AWG RED).

SECTION 10

Chip Conveyor

WRG_0045B_CE_wiring_Hennig_Chip_Conveyor

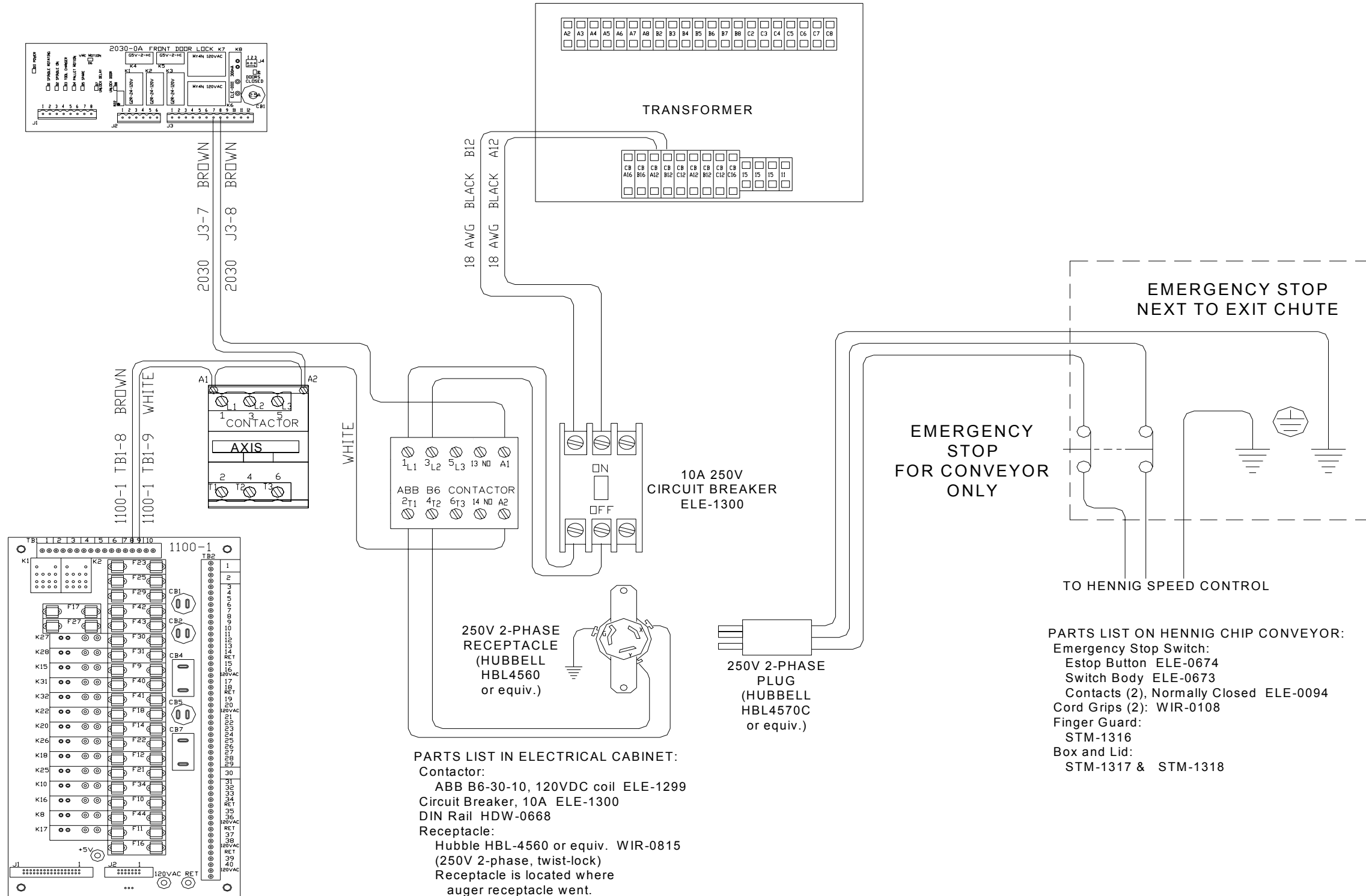

WRG_0062A_US wiring_Hennig_Chip_Conveyor

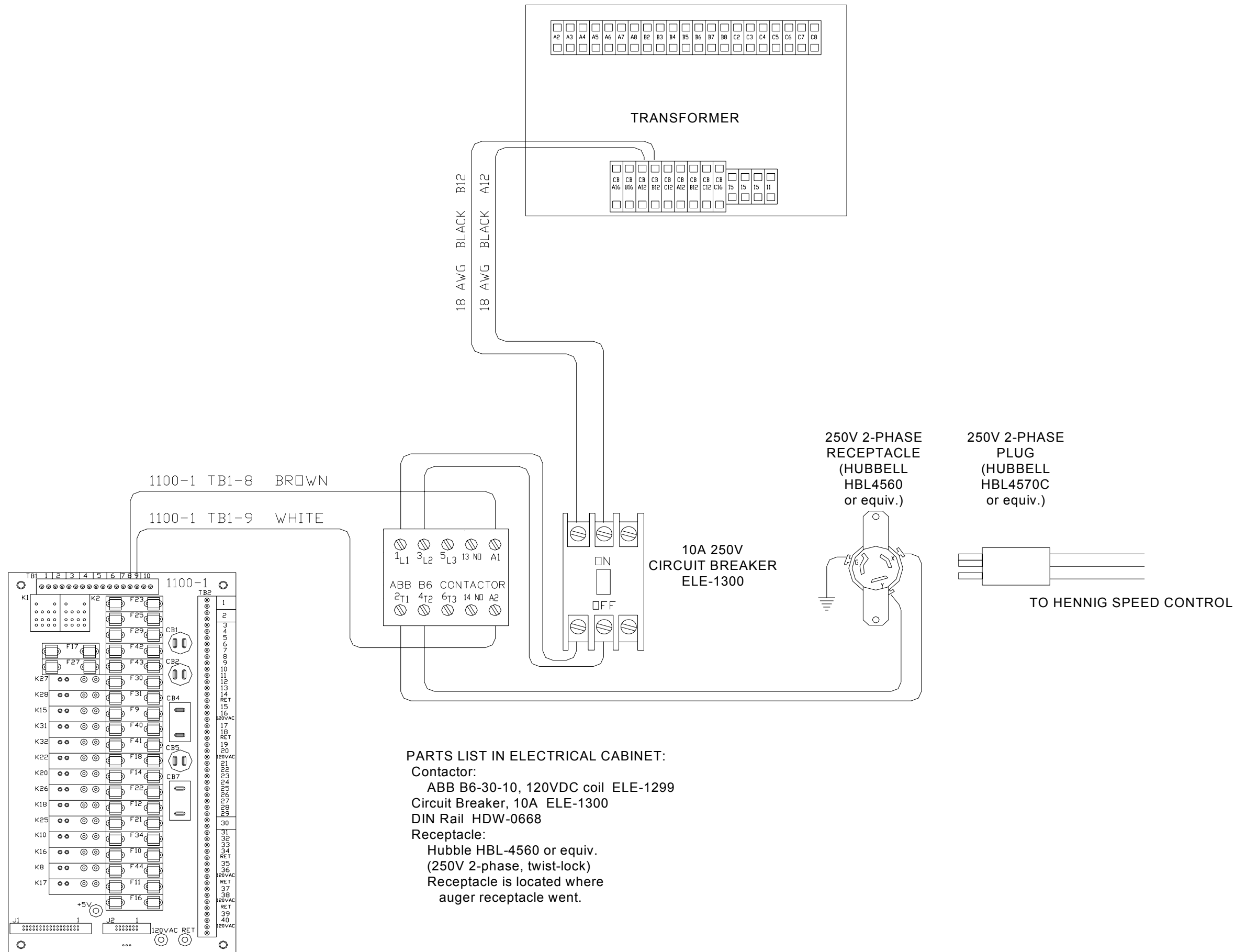

WRG_0063A_CE_wiring_Siemens_Hennig_Chip_Conveyor

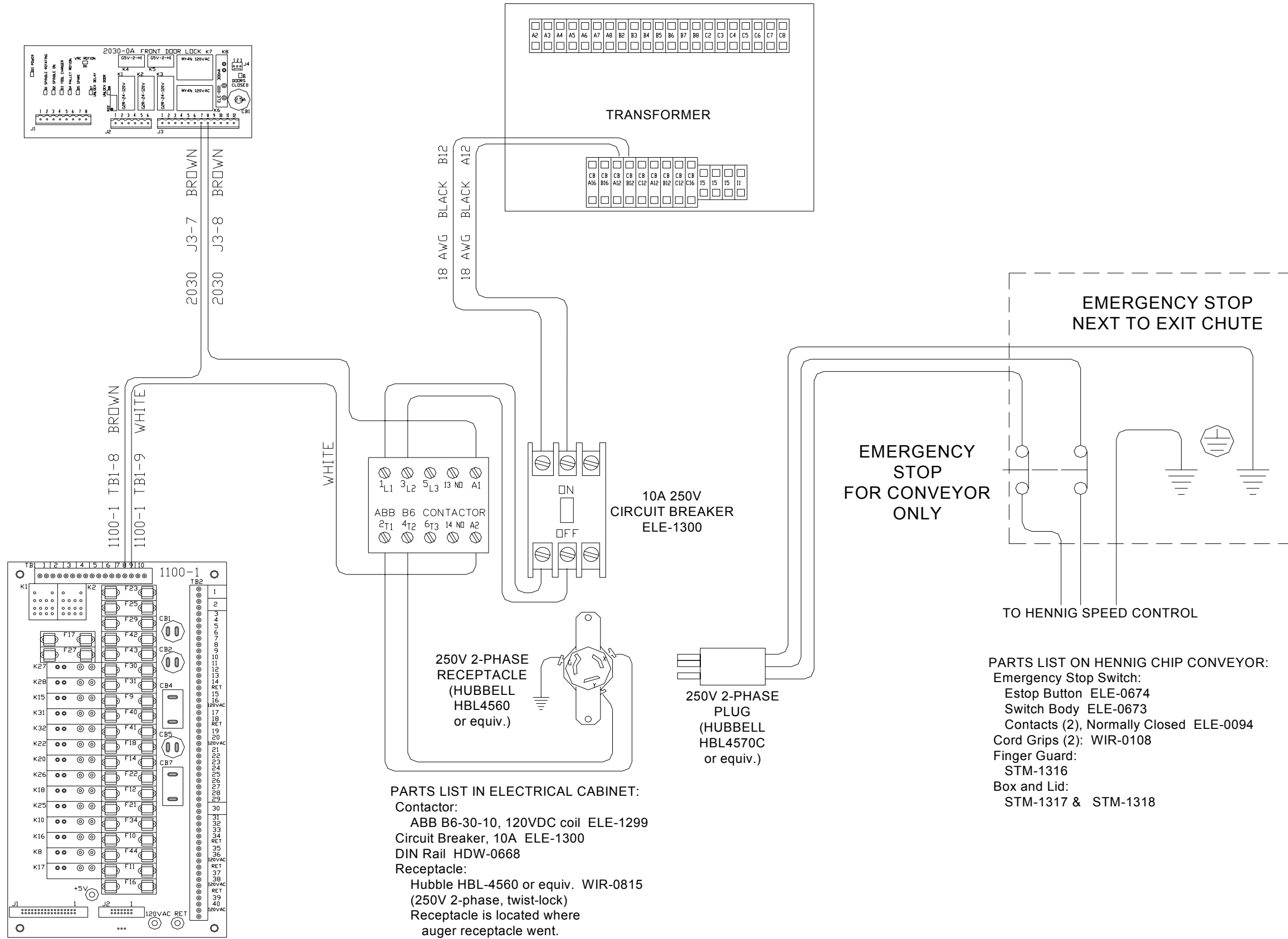

WRG_0083A_sht1of2_104D_US wiring_Hennig_Chip_Conveyor

PARTS LIST IN ELECTRICAL CABINET:

- Contactor:**
 ABB B6-30-10, 120VDC coil ELE-1299
 Circuit Breaker, 15A QOU315, ELE-1338
 DIN Rail HDW-0668
Relay and Socket:
 Omron MY4N, 120 VAC, ELE-0072
 Omron PYF14A-E, ELE-1440
Receptacle:
 Hubbell HBL-4560 or equiv. ELE-0815
 (250V 2-phase, twist-lock)
 Receptacle is located where
 auger receptacle went.

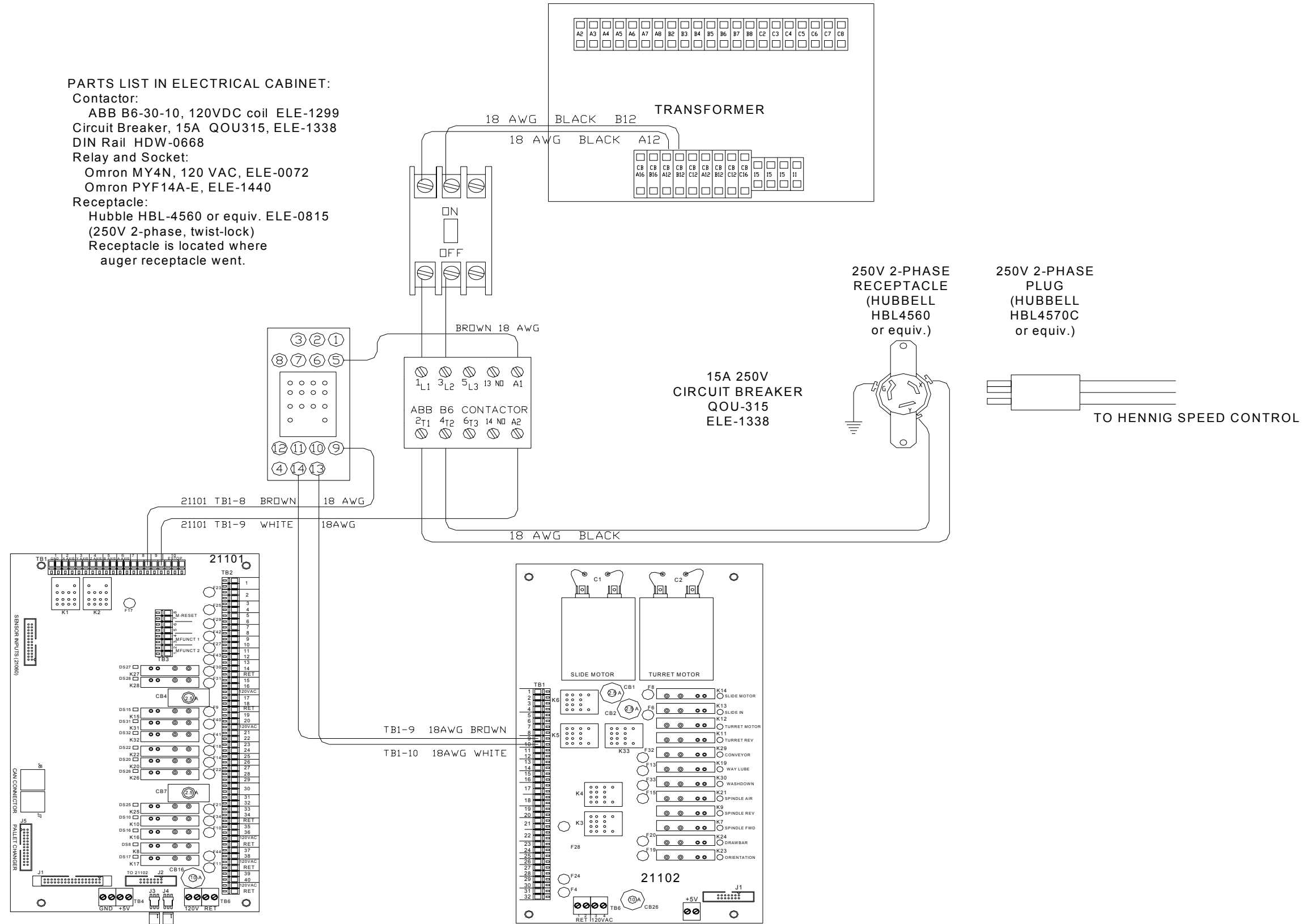

WRG_0083A_sht2of2_CE_wiring_Hennig_Chip_Conveyor 104D

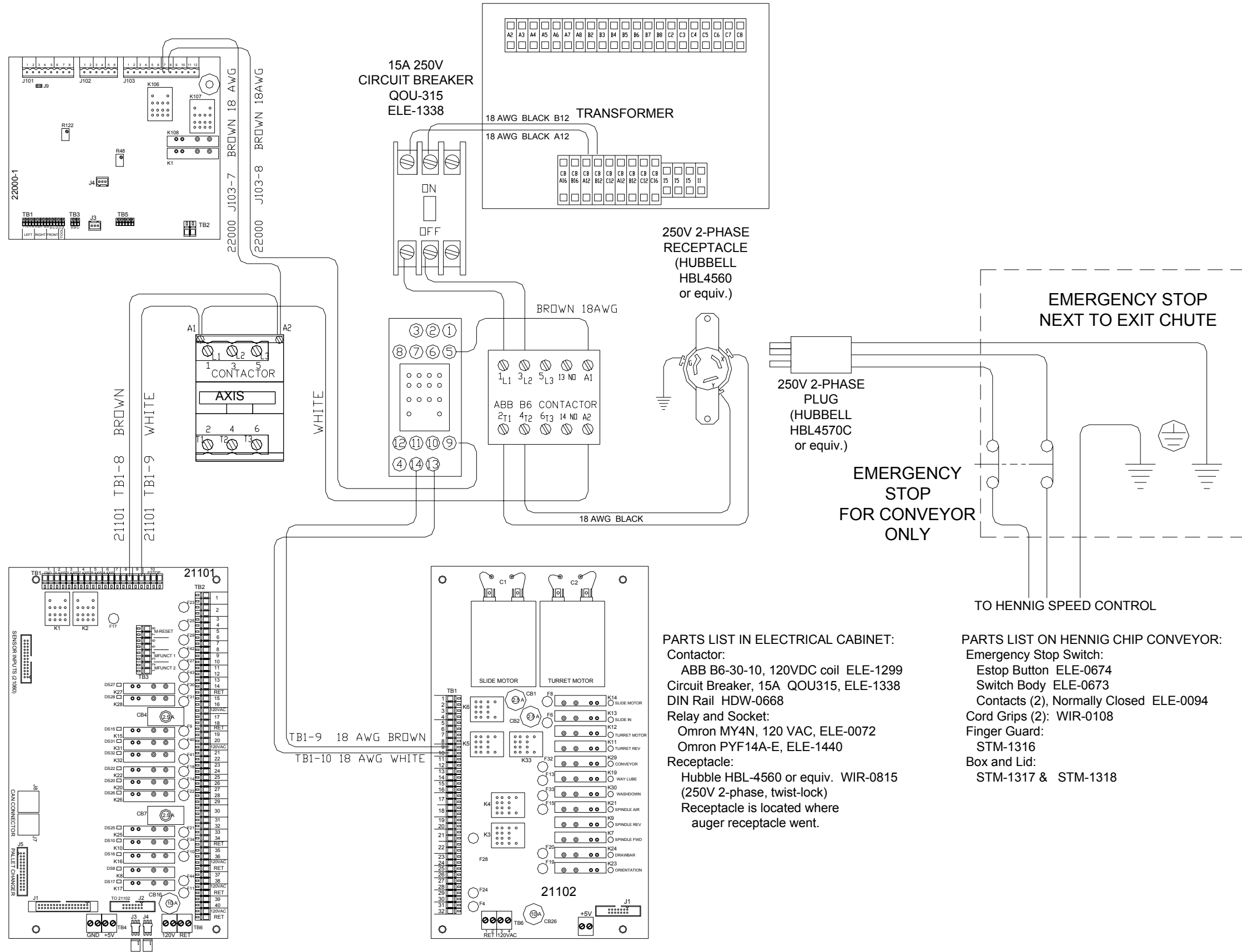

- PARTS LIST IN ELECTRICAL CABINET:**
- Contactor: ABB B6-30-10, 120VDC coil ELE-1299
 - Circuit Breaker, 15A QOU315, ELE-1338
 - DIN Rail HDW-0668
 - Relay and Socket: Omron MY4N, 120 VAC, ELE-0072
 - Omron PYF14A-E, ELE-1440
 - Receptacle: Hubble HBL-4560 or equiv. WIR-0815 (250V 2-phase, twist-lock)
 - Receptacle is located where auger receptacle went.

- PARTS LIST ON HENNIG CHIP CONVEYOR:**
- Emergency Stop Switch: Estop Button ELE-0674
 - Switch Body ELE-0673
 - Contacts (2), Normally Closed ELE-0094
 - Cord Grips (2): WIR-0108
 - Finger Guard: STM-1316
 - Box and Lid: STM-1317 & STM-1318

SECTION 11

Washdown

WRG_0037F_auger_washdown_coolantthru

1310 PIN LIST

- J1**
 - 120 VAC (INPUT)
 - PUMP
 - VALVE #1
 - VALVE #2
 - VALVE #3
 - 120 RETURN (INPUT)
 - E-STOP (INPUT)
 - CONTACTOR FOR AUGER
 - CONTACTOR FOR SPINDLE
 - RETURN FOR SPINDLE CONTACTOR
 - RETURN FOR AUGER CONTACTOR AND PUMP STARTER
 - RETURN FOR VALVE COILS
- J2**
 - 1-3. AUGER MOTOR
 - 4-7. 220 VAC
- J3**
 - START/STOP BUTTON
 - MODE SWITCH
 - M-FUNCTION INPUT
 - POT
 - +5V FOR PDT
 - GROUND
 - EXTERNAL RESET
 - +5V
 - +5V (INPUT)
 - GROUND (INPUT)
 - EXTERNAL SLIDE HOLD OUTPUT
 - GROUND FOR EXTERNAL SLIDE HOLD
- J4**
 - LEFT DOOR SWITCH (BLK)
 - LEFT DOOR SWITCH (WHT)
 - LEFT DOOR SWITCH (RED)
 - LEFT DOOR SWITCH (GRN)
 - RIGHT DOOR SWITCH (BLK)
 - RIGHT DOOR SWITCH (WHT)
 - RIGHT DOOR SWITCH (RED)
 - RIGHT DOOR SWITCH (GRN)
 - FRONT DOOR SWITCH (BLK)
 - FRONT DOOR SWITCH (WHT)
 - FRONT DOOR SWITCH (RED)
 - FRONT DOOR SWITCH (GRN)

- K1 - SSR ELE-0070 TURN ON PUMP.
- K2 - SSR ELE-0070 VALVE 1.
- K3 - SSR ELE-0070 VALVE 2.
- K4 - SSR ELE-0070 VALVE 3.
- K6 - SSR ELE-0070 3 POLE RELAY 240V.
- K101 - SSR ELE-0101 SPINDLE RELAY

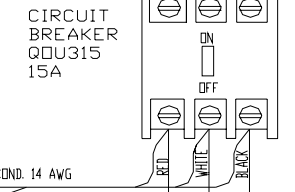
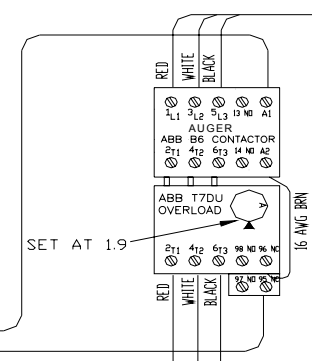
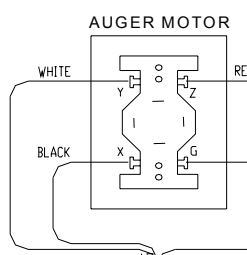
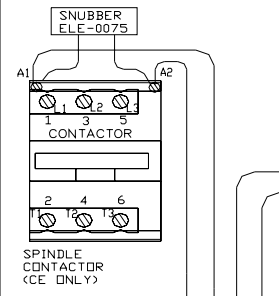

T-820 TRANSFORMER

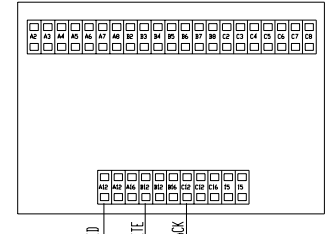

NOTE: IF MACHINE HAS ALSO HAS PALLET CHANGER AND DUAL ARM TDL CHANGER THEN A SECOND 15 A CIRCUIT BREAKER WILL BE REQUIRED. UL LIMIT FOR BRANCH MOTOR PROTECTION IS 15 A.

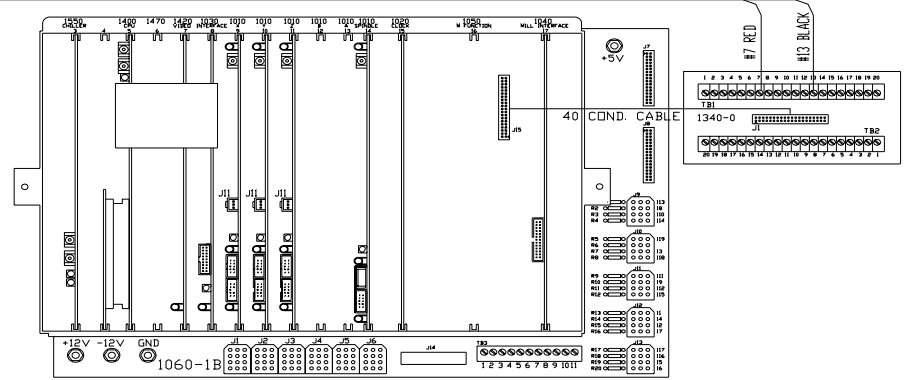
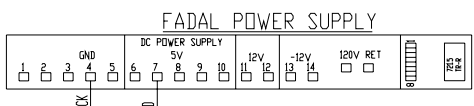
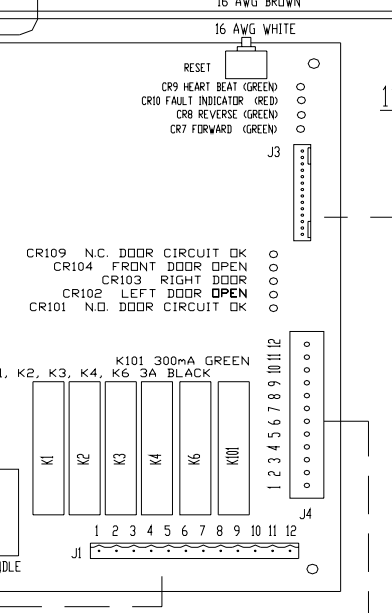
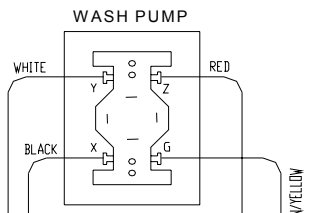
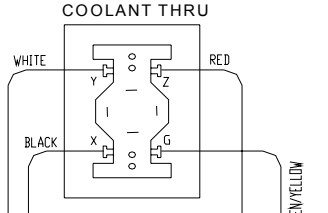
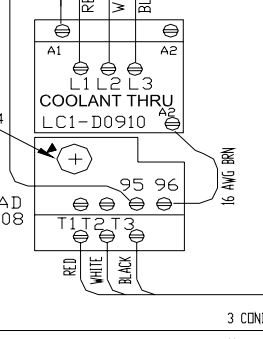
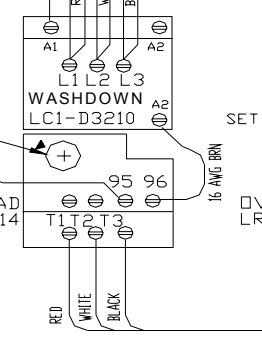
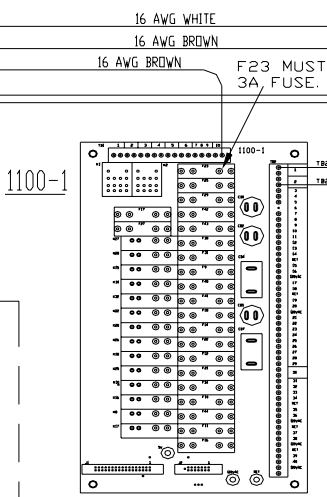

NOTE: REMOVE DOOR INTERLOCK FROM J13 PIN 8 & INSTALL AUGER INTERLOCK

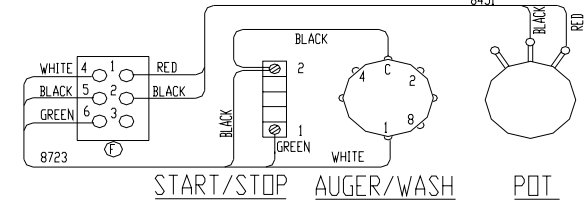
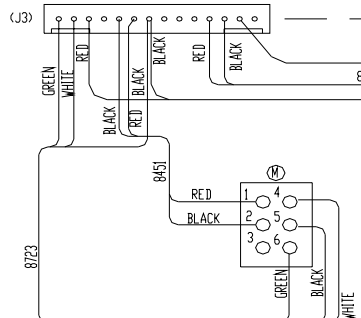
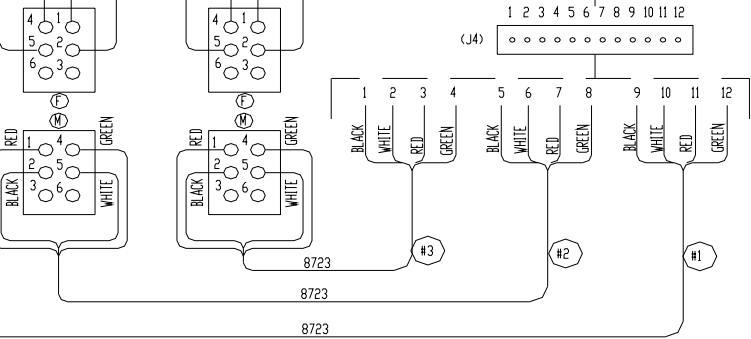
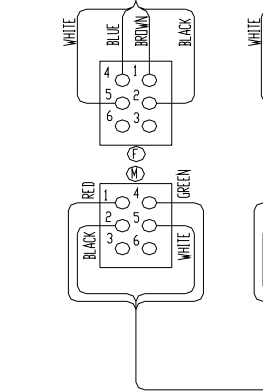
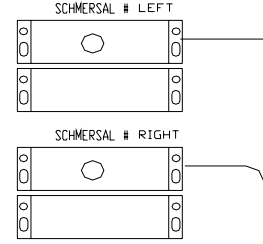

WRG_0044D_6535_washdown

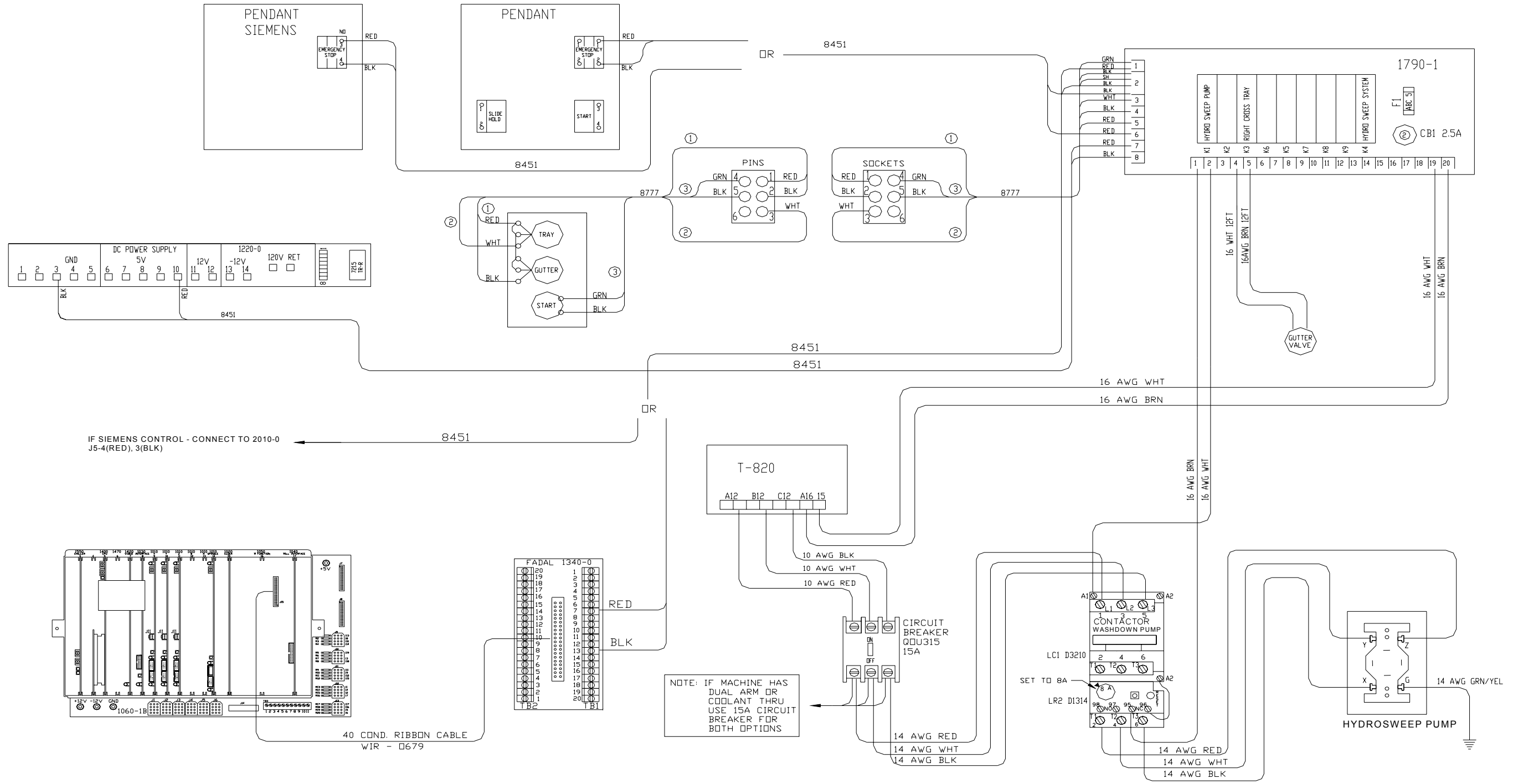

Wrg_0081X_15of22_hmc_wash_conv_cool

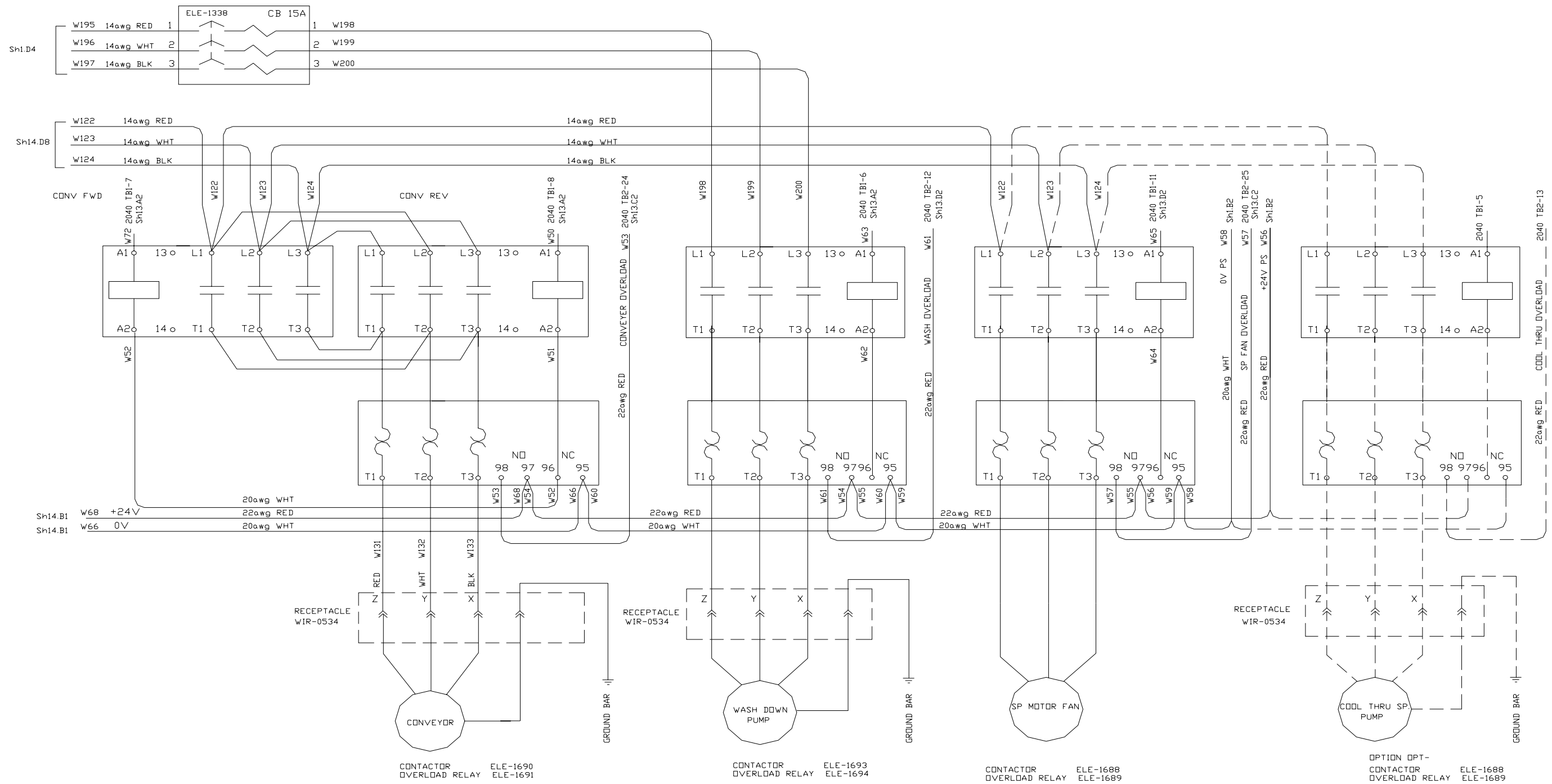

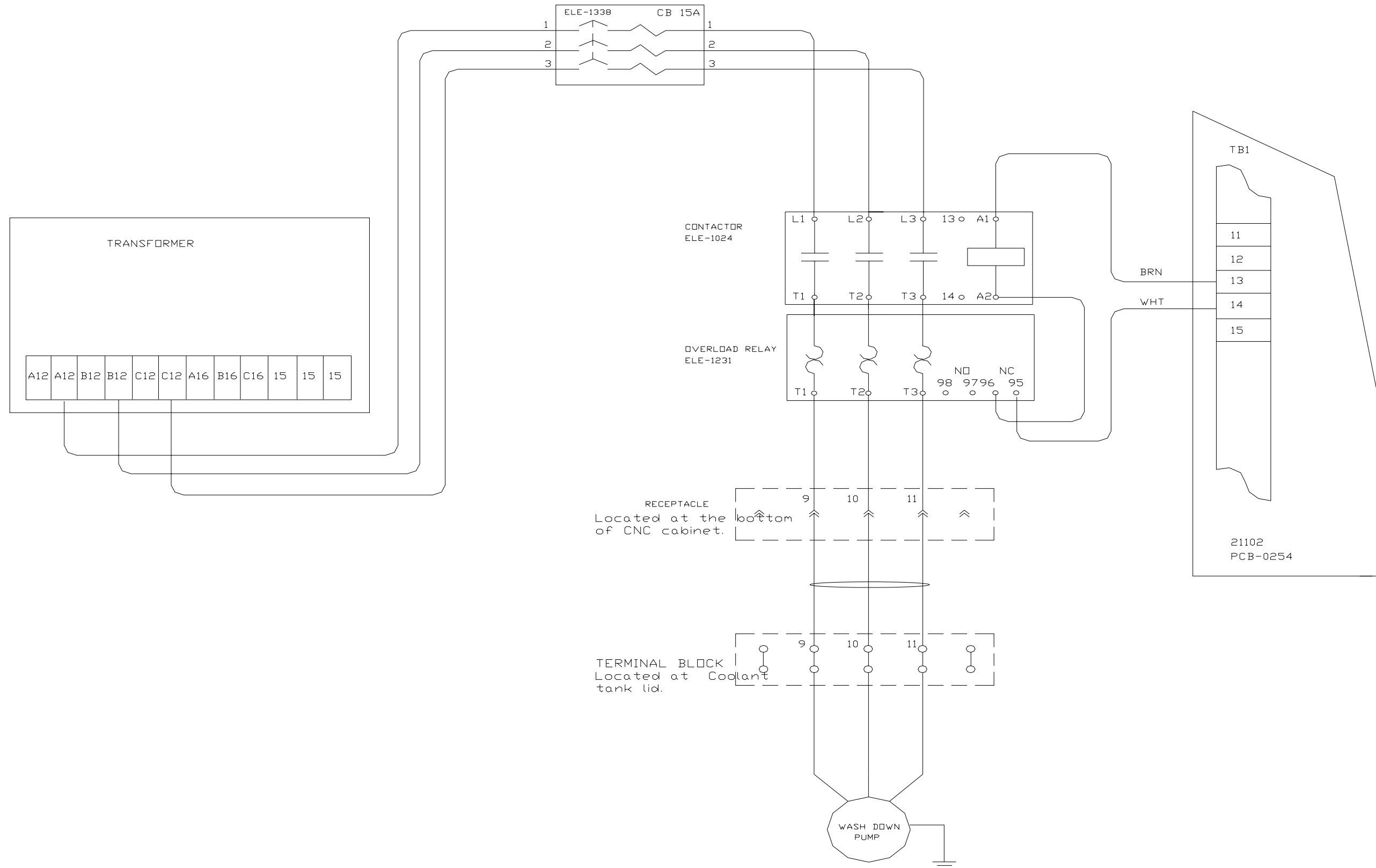

WRG_0693J_auger_washdown_wiring_diagram

1310 PIN LIST

- J1**
 - 120 VAC (INPUT)
 - PUMP
 - VALVE #1
 - VALVE #2
 - VALVE #3
 - 120 RETURN (INPUT)
 - E-STOP (INPUT)
 - CONTACTOR FOR AUGER
 - CONTACTOR FOR SPINDLE
 - RETURN FOR SPINDLE CONTACTOR
 - RETURN FOR AUGER CONTACTOR
 - AND PUMP STARTER
 - RETURN FOR VALVE COILS
- J2**
 - 1-3. AUGER MOTOR
 - 4-7. 220 VAC
- J3**
 1. START/STOP BUTTON
 - MODE SWITCH
 - M-FUNCTION INPUT
 - POT
 - +5V FOR POT
 - +5V
 - GROUND
 - EXTERNAL RESET
 - +5V
 - +5V (INPUT)
 - GROUND (INPUT)
 - EXTERNAL SLIDE HOLD OUTPUT
 - GROUND FOR EXTERNAL SLIDE HOLD
- J4**
 1. LEFT DOOR SWITCH (BLK)
 2. LEFT DOOR SWITCH (WHT)
 3. LEFT DOOR SWITCH (RED)
 4. LEFT DOOR SWITCH (GRN)
 5. RIGHT DOOR SWITCH (BLK)
 6. RIGHT DOOR SWITCH (WHT)
 7. RIGHT DOOR SWITCH (RED)
 8. RIGHT DOOR SWITCH (GRN)
 9. FRONT DOOR SWITCH (BLK)
 10. FRONT DOOR SWITCH (WHT)
 11. FRONT DOOR SWITCH (RED)
 12. FRONT DOOR SWITCH (GRN)

- K1 - SSR ELE-0070 TURN ON PUMP.
- K2 - SSR ELE-0070 VALVE 1.
- K3 - SSR ELE-0070 VALVE 2.
- K4 - SSR ELE-0070 VALVE 3.
- K6 - SSR ELE-0070 3 POLE RELAY 240V.
- K101 - SSR ELE-0101 SPINDLE RELAY

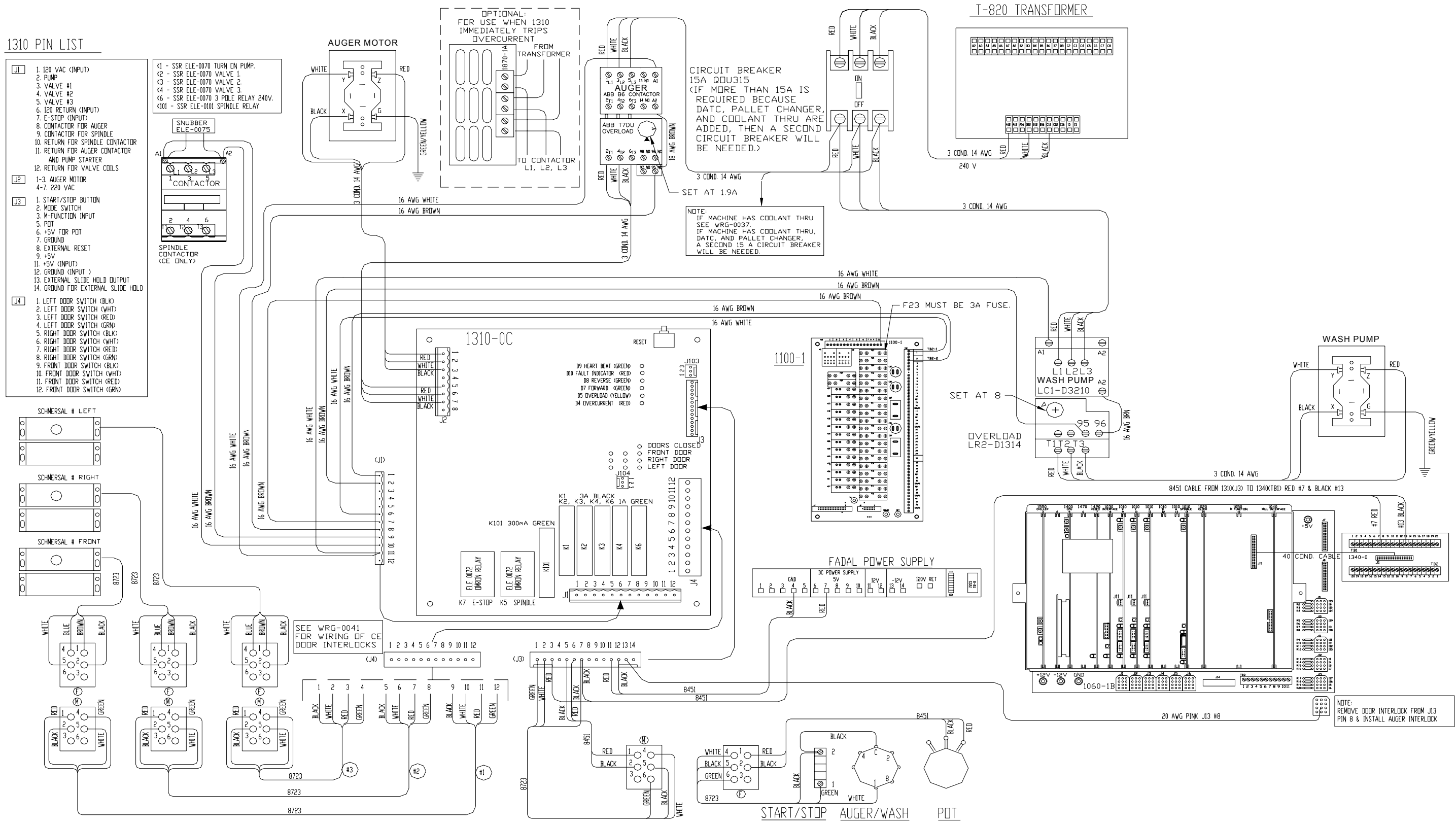

SECTION 12

104D

Wrg_0069A_01of12_104d_21101_std

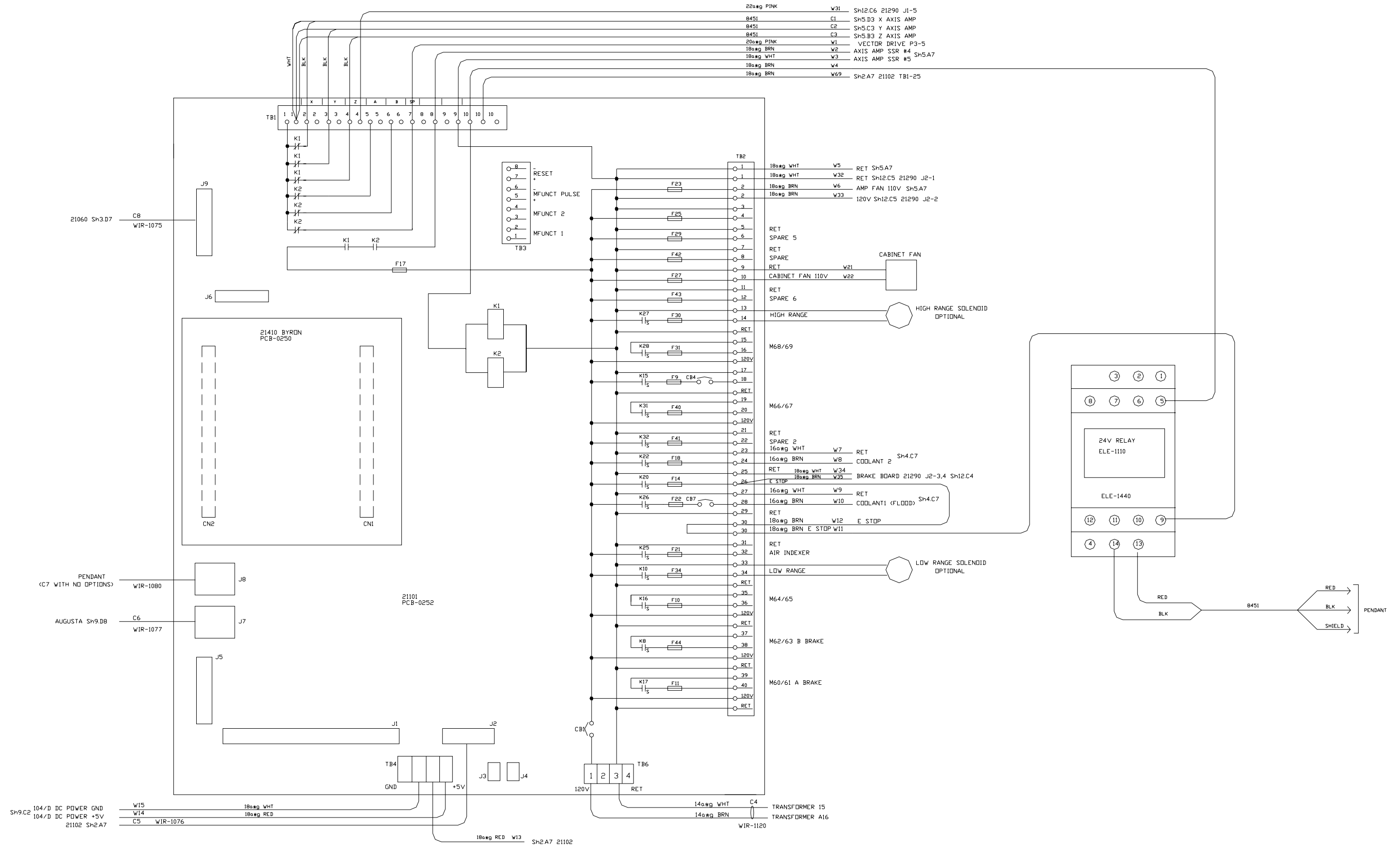

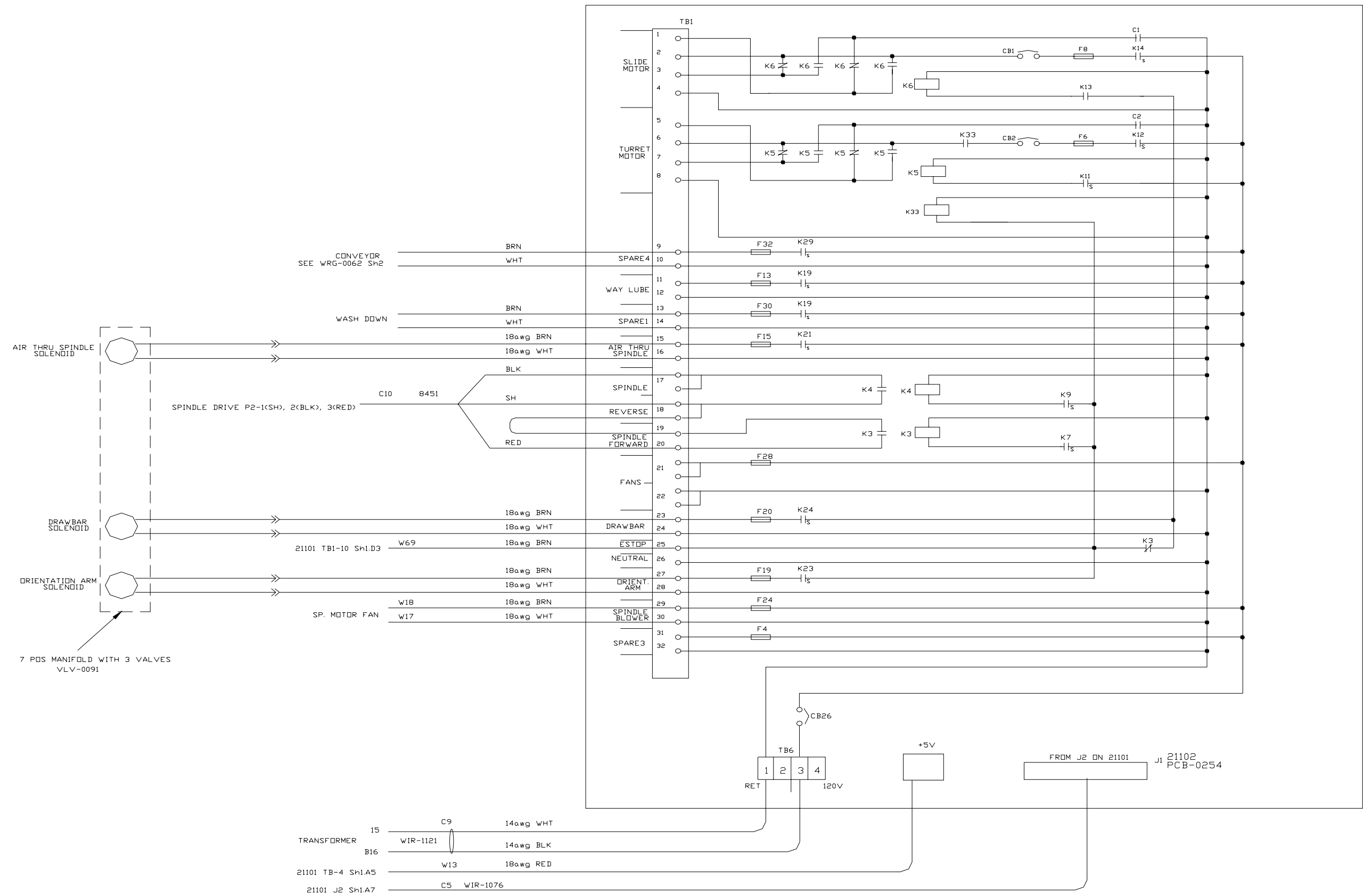

Wrg_0069A_03of12_104d_21060_std

104/D +12VDC Sh9.C2 W19 220wg YELLOW
 104/D DIGITAL IN-1 Sh9.A8 W20 220wg RED ORIENTATION MAGNET
 21101 J9 Sh1.C8 C10

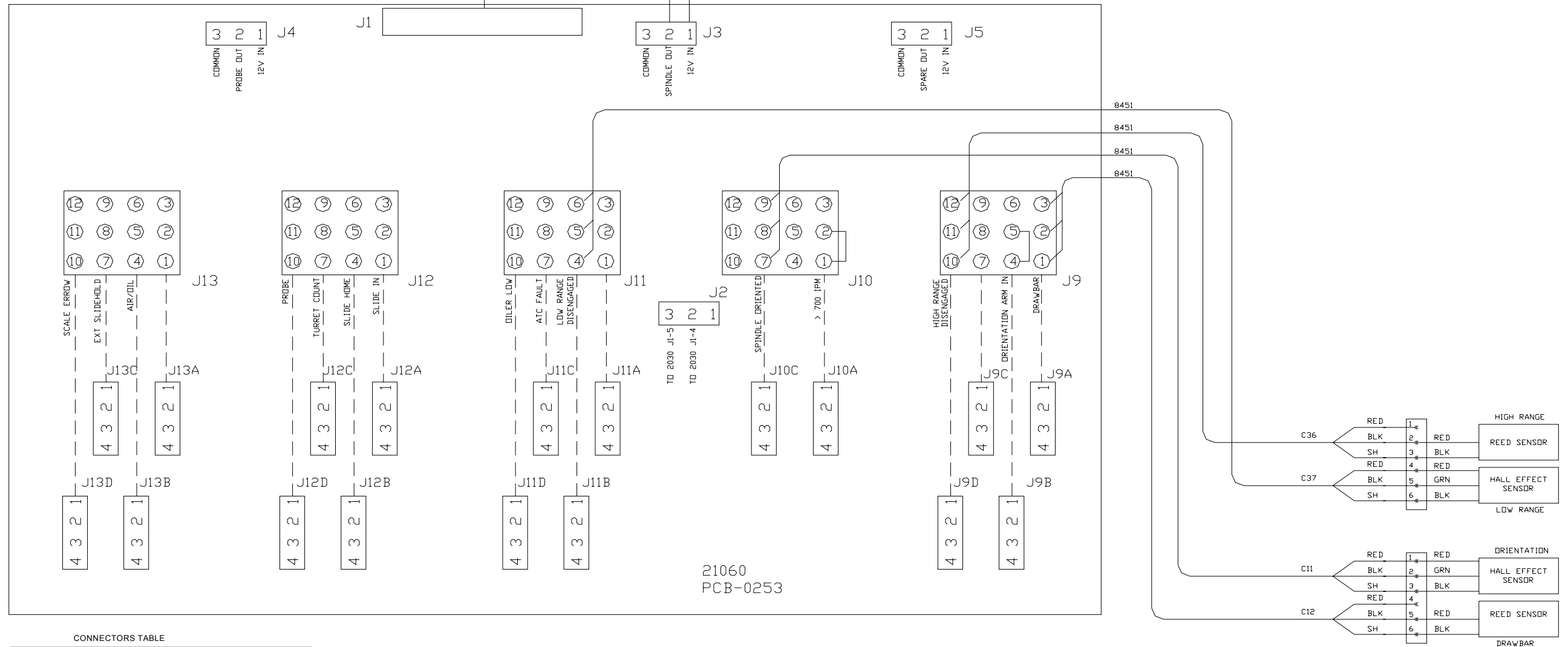

21060
PCB-0253

CONNECTOR J1

PIN	SIGNAL
1	SLIDE EXTENDED
2	TURRET COUNT
3	SPINDLE ORIENTED
4	SLIDE HOME
5	EXT SLIDE HOLD
6	SCALE ERROR
7	PROBE
8	OVER 700 IPM
9	ORIENTATION ARM
10	LOW RANGE
11	SPARE
12	AIR/OIL
13	ATC FAULT
14	DRAWBAR DOWN
15	HI RANGE
16	OILER LOW
17	SPARE
18	SPARE
19	+5V
20	+5V
21	+5V
22	+5V
23	COM
24	COM
25	COM
26	COM

CONNECTORS TABLE

	PIN	SENSOR
J9/J9A	1-SH, 2-BLK, 3-RED	DRAWBAR
J9/J9D	10-SH, 11-BLK, 12-RED	HI RANGE
J10/J10C	7-SH, 8-BLK, 9-RED	SPINDLE ORIENTED
J11/J11B	4-SH, 5-BLK, 6-RED	LOW RANGE
J11/J11C	7-SH/BLK, 8-RED	ATC FAULT
J11/J11D	10-ORANGE, 11-RED	OILER LOW
J12/J12A	1-SH, 2-BLK, 3-RED	SLIDE EXTENDED
J12/J12B	4-SH, 5-BLK, 6-RED	SLIDE HOME
J12/J12C	7-SH, 8-BLK, 8-RED	TURRET COUNT
J13/J13C	7-SH/BLK, 8-RED	EXT SLIDE HOLD/DOOR INTERLOCK

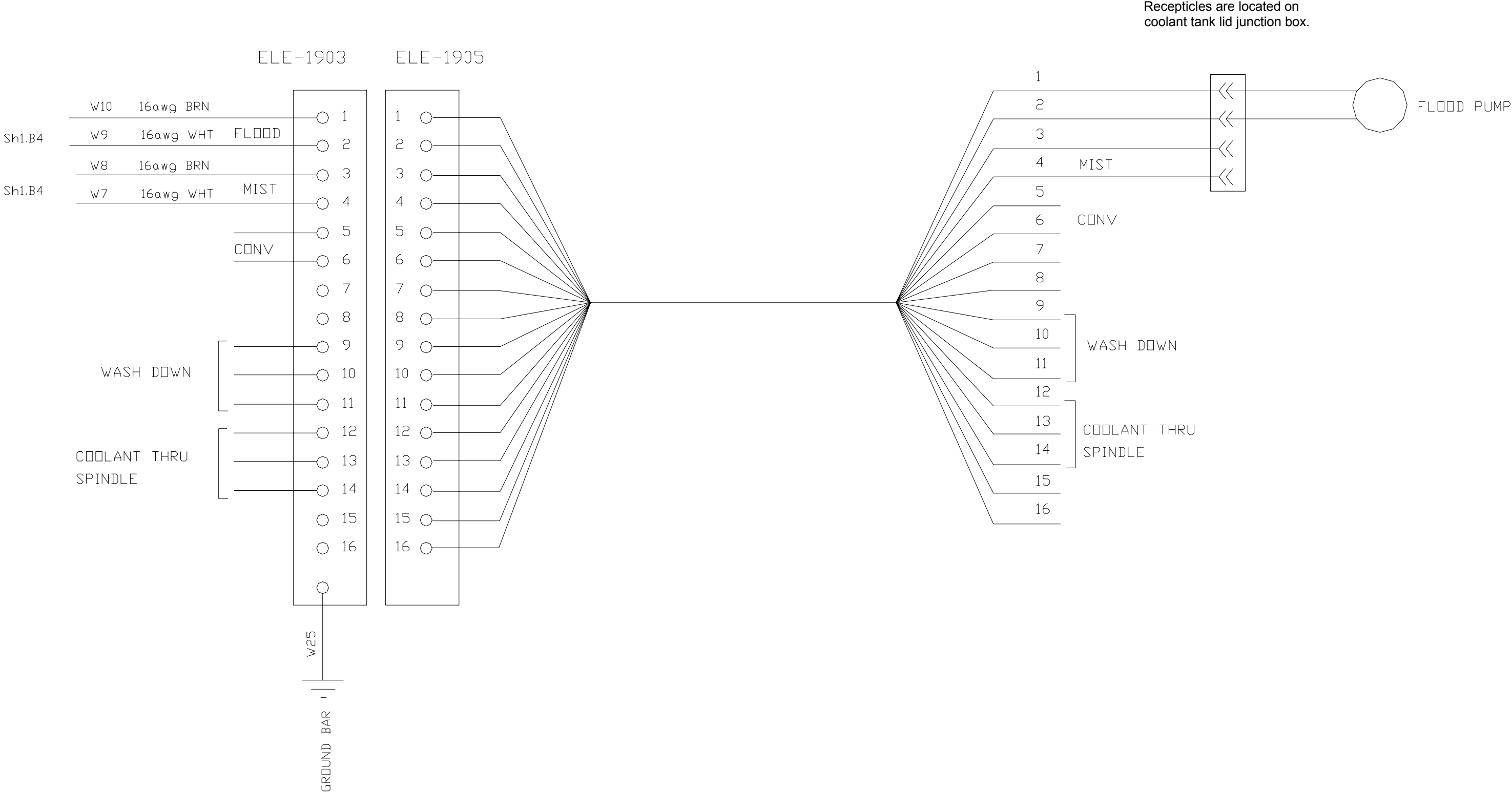

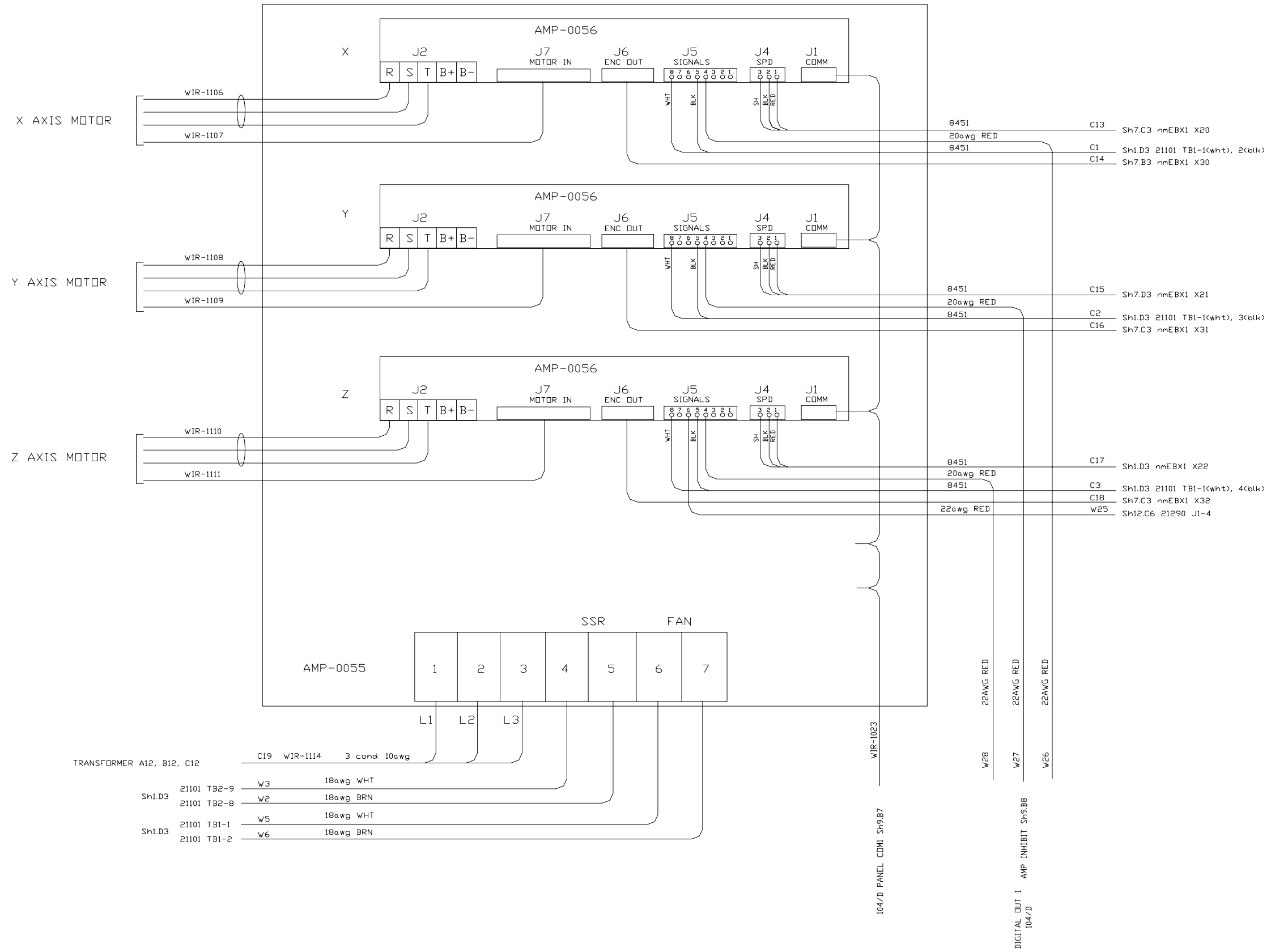

Wrg_0069A_06of12_104d_dc_power_supply_std

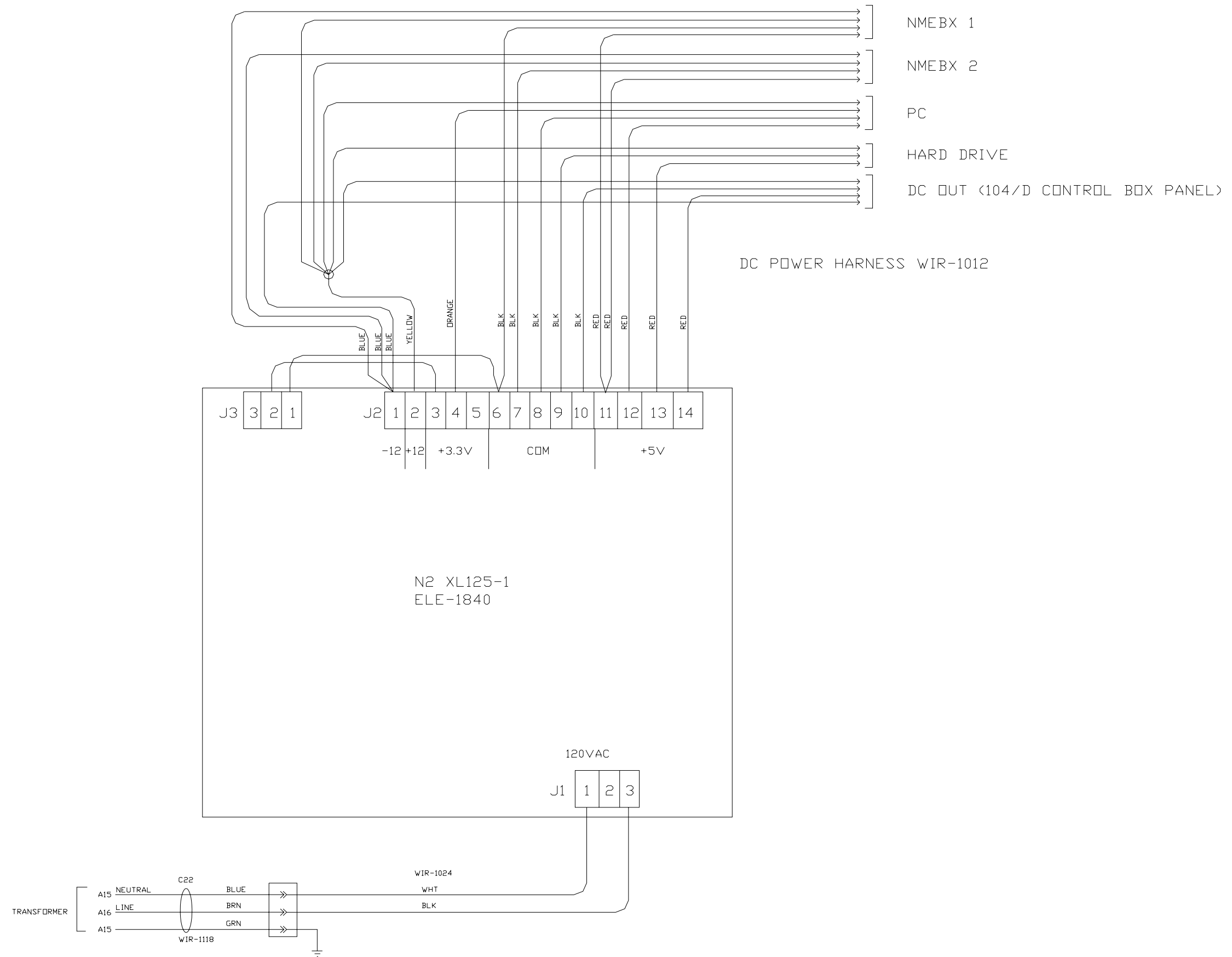

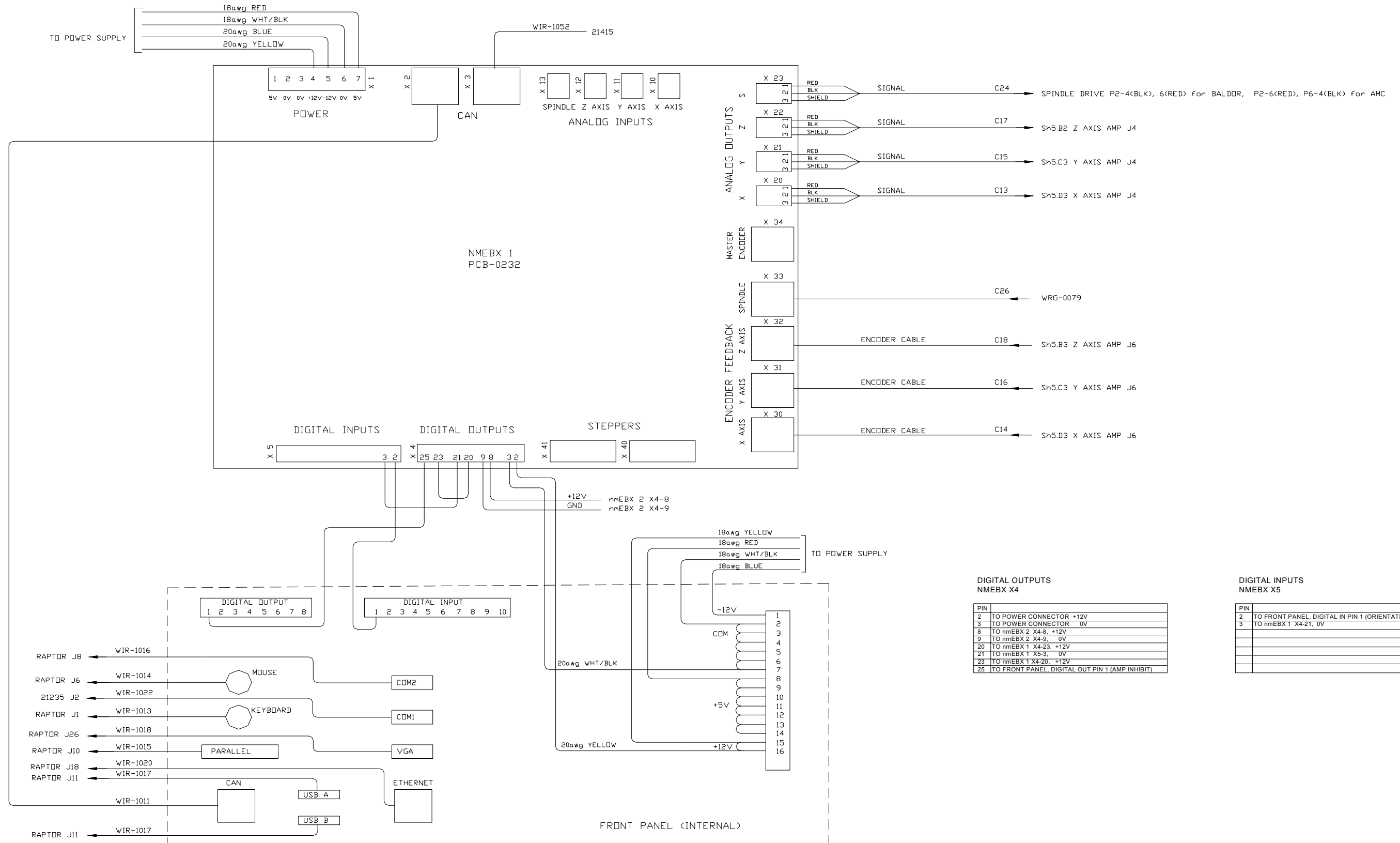

DIGITAL OUTPUTS NMEBX X4

PIN	DESCRIPTION
2	TO POWER CONNECTOR +12V
3	TO POWER CONNECTOR 0V
8	TO nmEBX 2 X4-8, +12V
9	TO nmEBX 2 X4-9, 0V
20	TO nmEBX 1 X4-23, +12V
21	TO nmEBX 1 X5-3, 0V
23	TO nmEBX 1 X4-20, +12V
25	TO FRONT PANEL, DIGITAL OUT PIN 1 (AMP INHIBIT)

DIGITAL INPUTS NMEBX X5

PIN	DESCRIPTION
2	TO FRONT PANEL, DIGITAL IN PIN 1 (ORIENTATION MAGNET)
3	TO nmEBX 1 X4-21, 0V

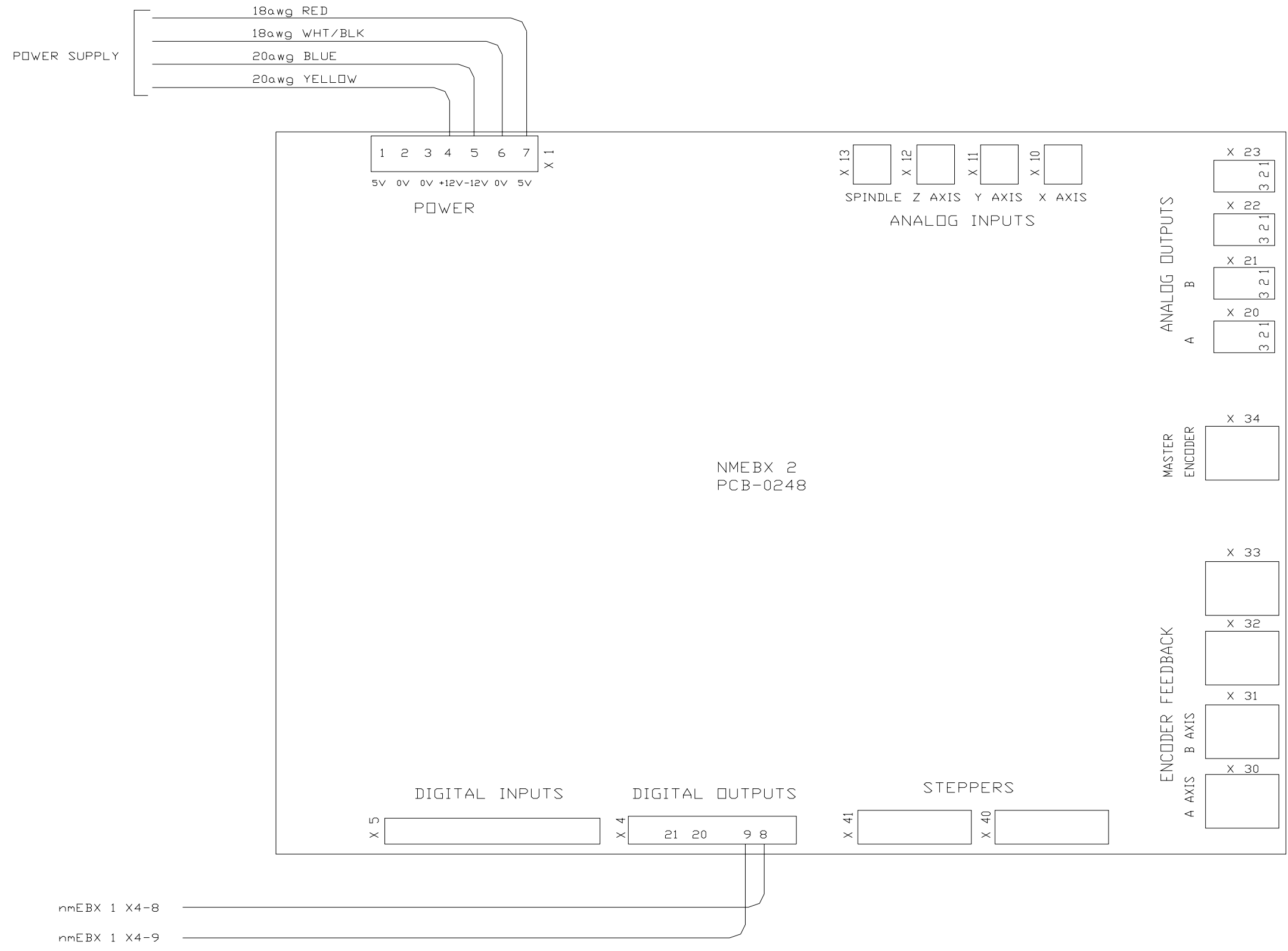

Wrg_0069A_09of12_104d_box_panel_std

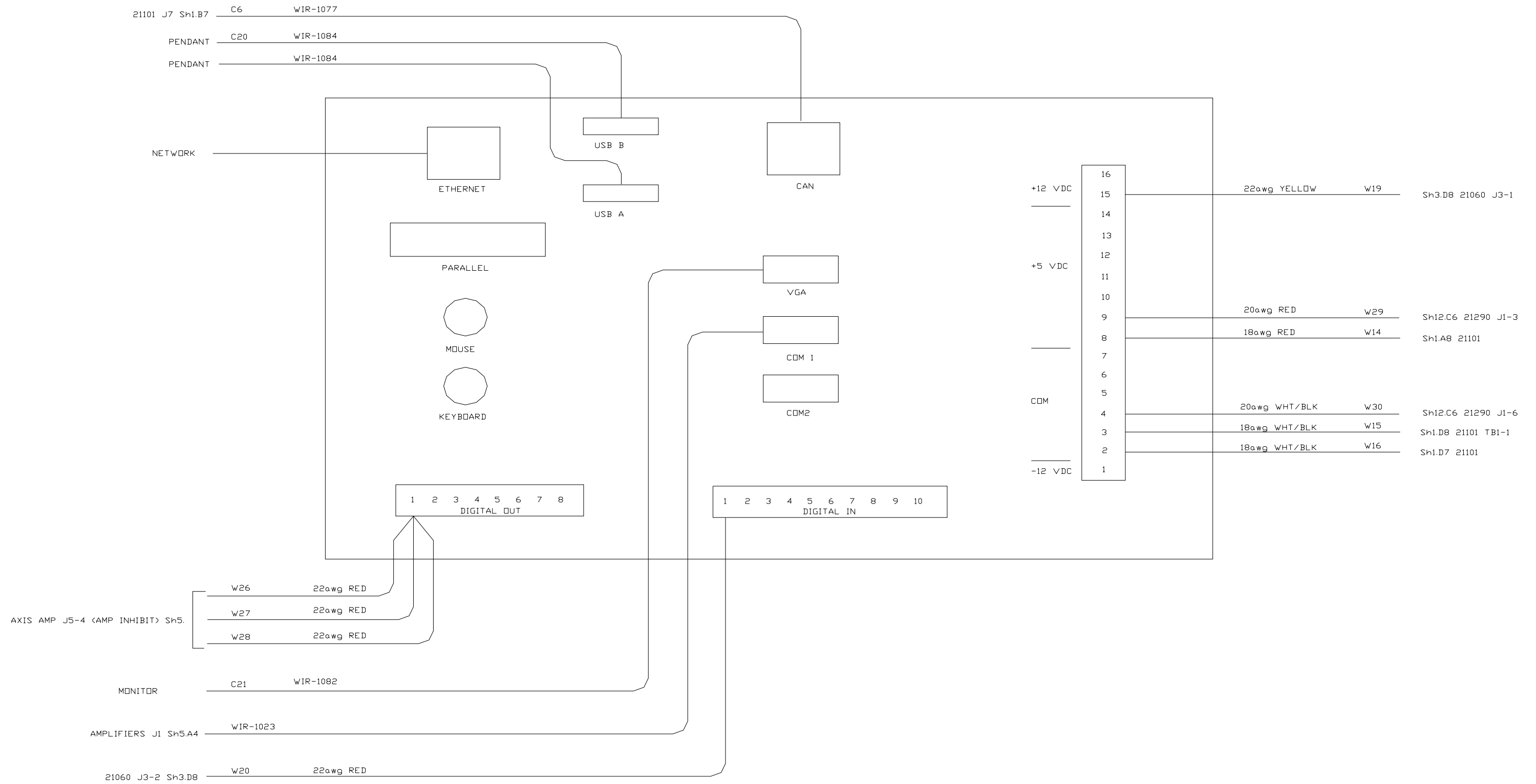

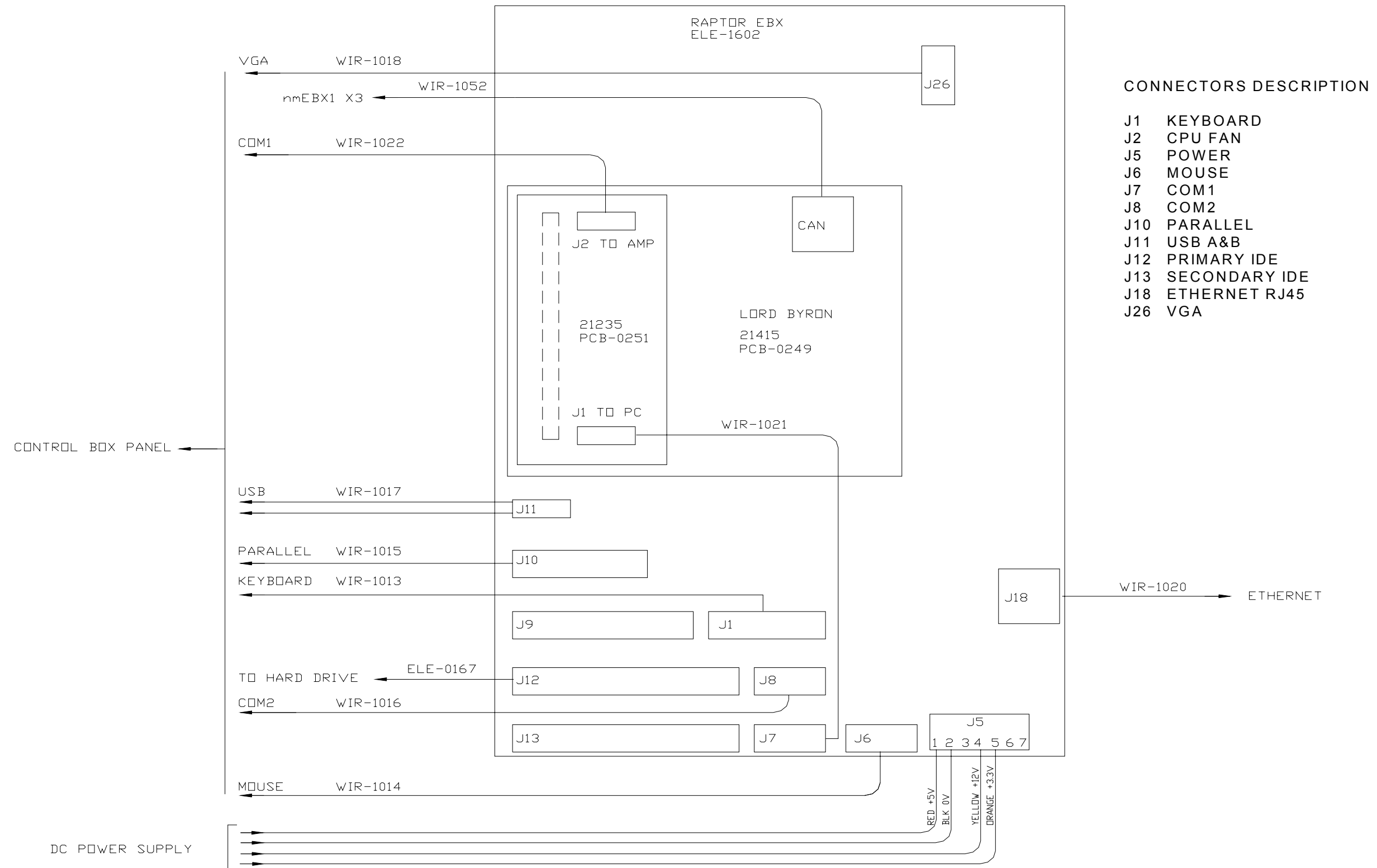

Wrg_0069A_11of12_104d_24vdc_power_supply_std

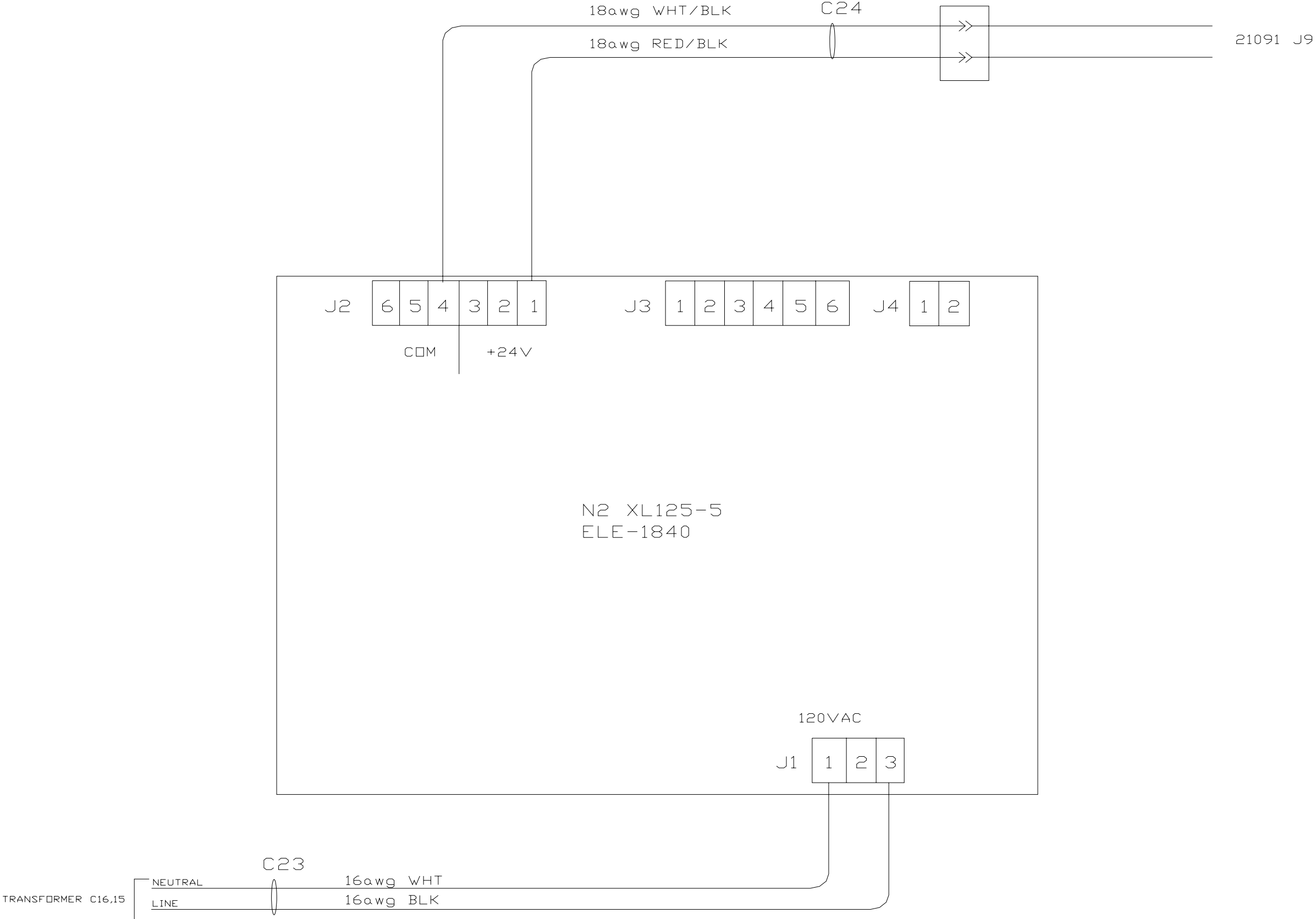

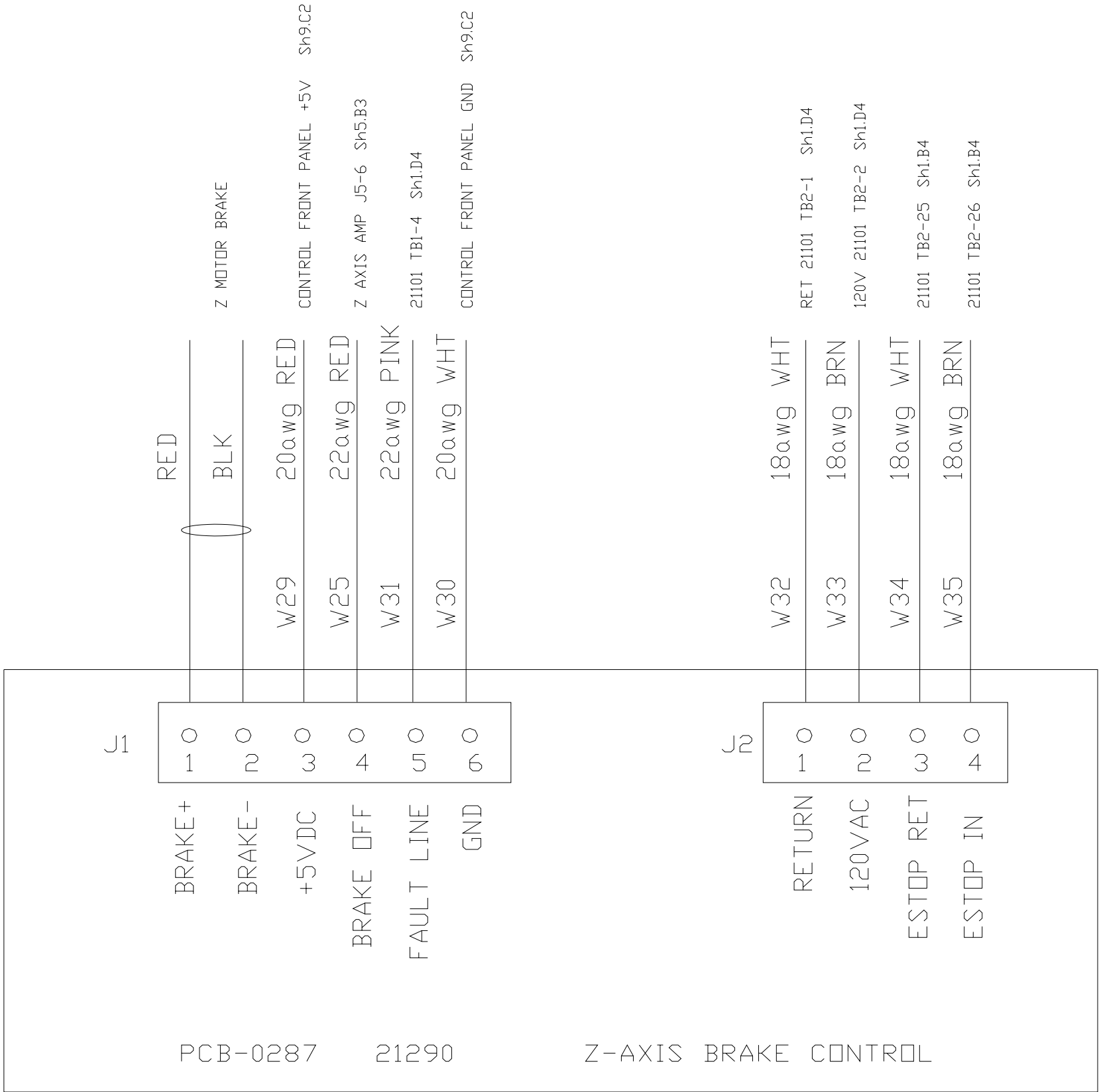

Wrg_0070A_1of5_104d_can_ethernet_usb_cable

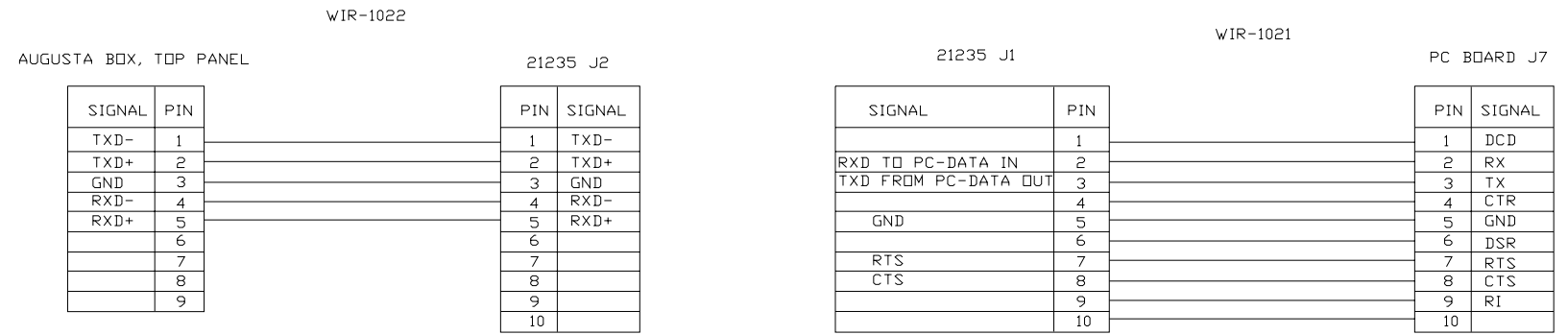
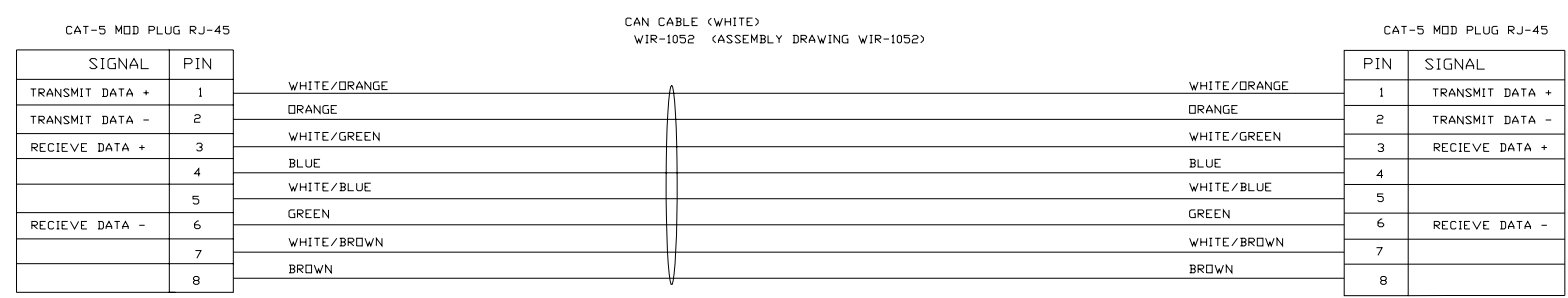
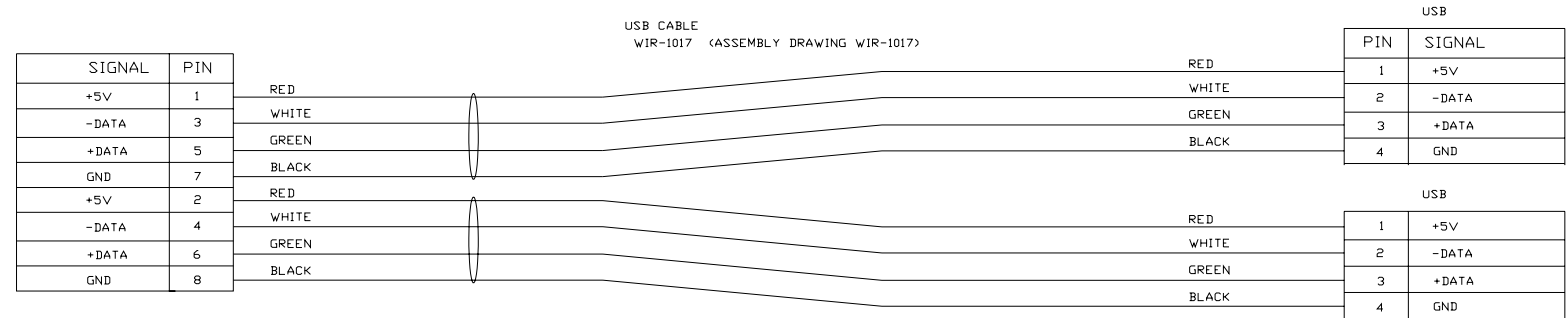
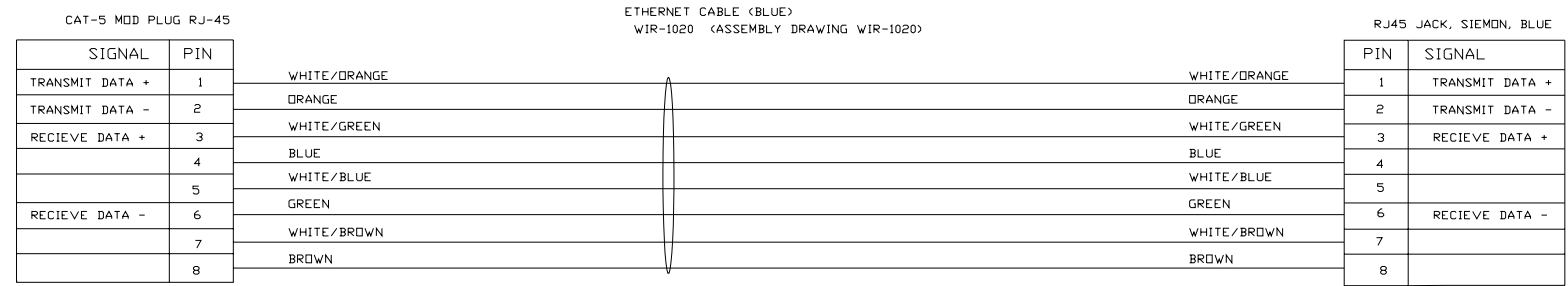
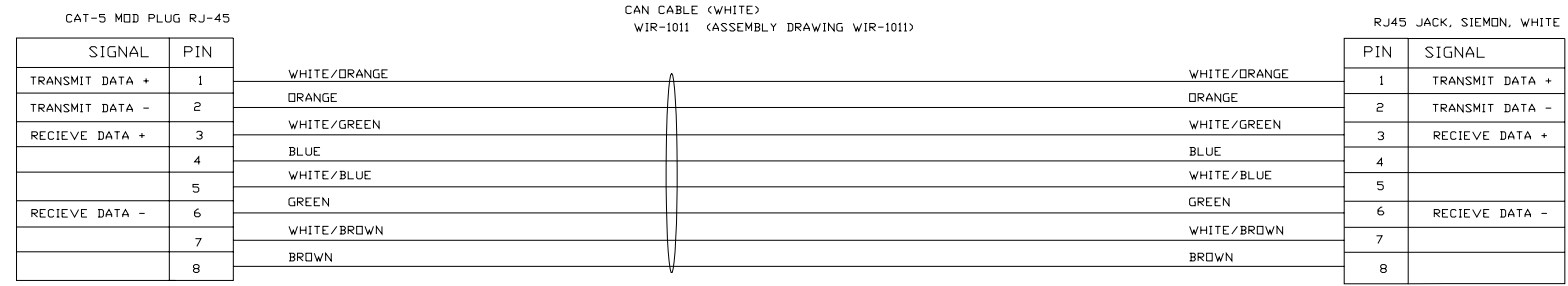

Wrg_0070A_2of5_104d_in_out_nmebx

WIR-1019 (ASSEMBLY DRAWING WIR-1019)

nmEBX 2
DIGITAL OUT

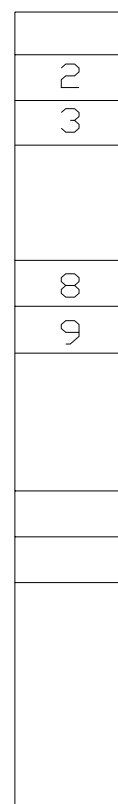

nmEBX 1
DIGITAL OUT

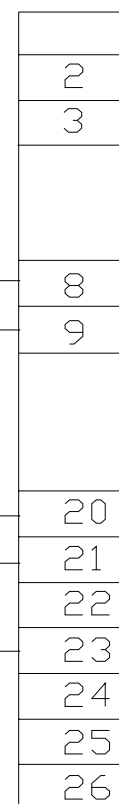

22awg YELLOW POWER CONNECTOR +12V
22awg WHT/BLK POWER CONNECTOR 0V

+12V 22awg YELLOW
0V 22awg WHT/BLK

+12V

22awg RED DIGITAL OUT (AUGUSTA BOX PANEL) - 1

nmEBX 1
DIGITAL IN



22awg RED DIGITAL IN (AUGUSTA BOX PANEL) - 1

0V

Wrg_0070A_3of5_104d_keyboard_mause_cable

MOUSE
WIR-1014 (ASSEMBLY DRAWING WIR-1014)

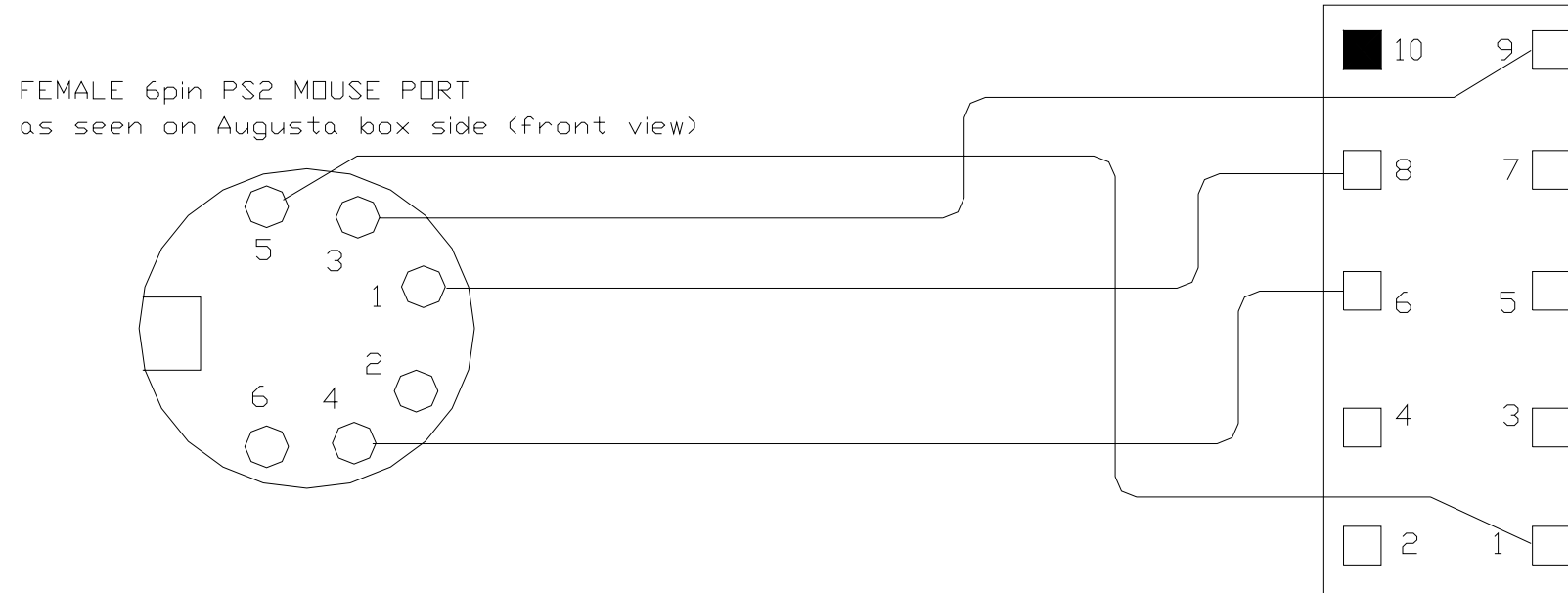

MOUSE CON. 10pin

PIN	SIGNAL
1	CLOCK
6	+5V
8	DATA
9	GROUND
10	MECHANICAL KEY

KEYBOARD
WIR-1013 (ASSEMBLY DRAWING WIR-1013)

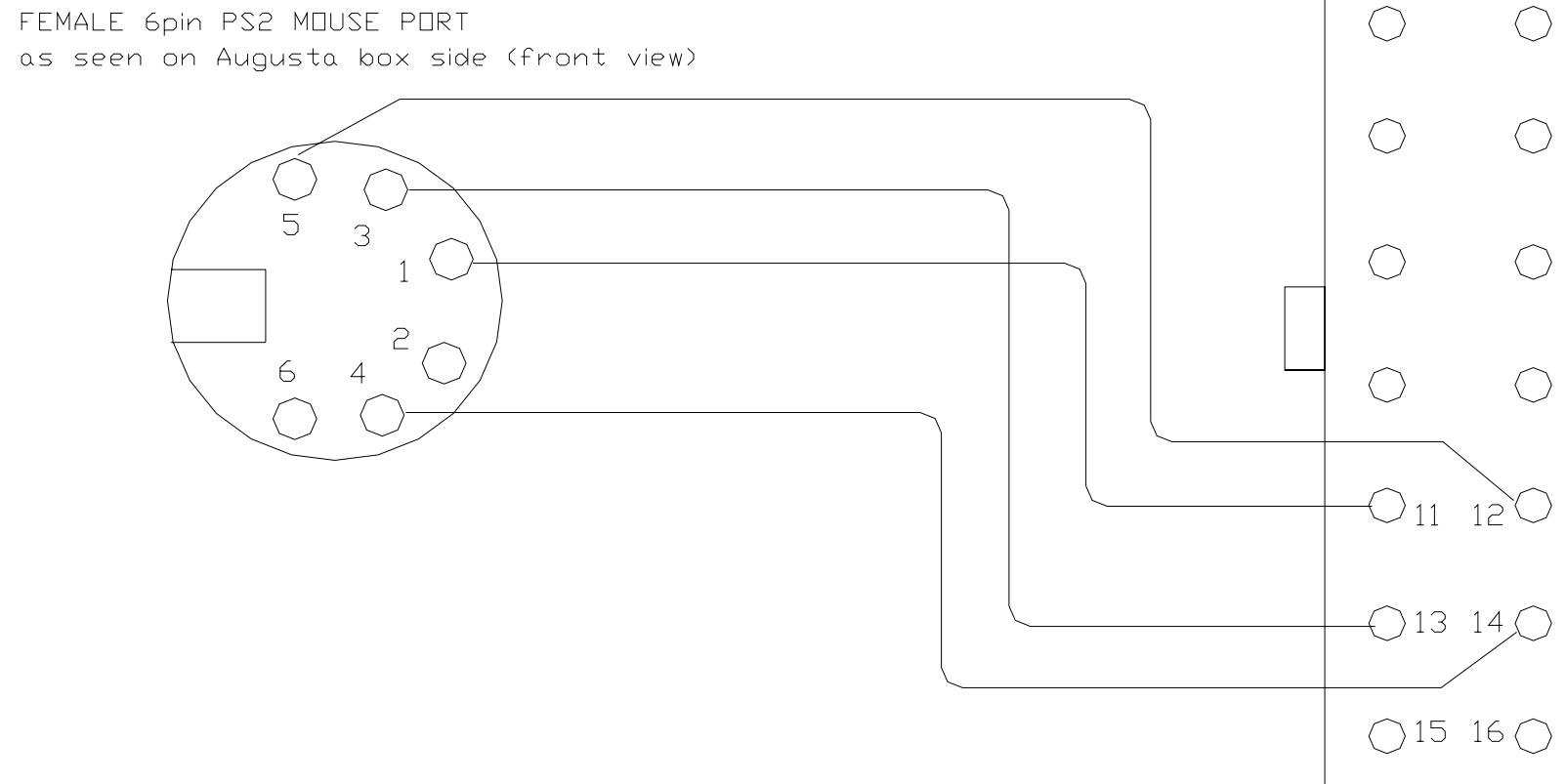

KEYBOARD CON. 16pin

PIN	SIGNAL
11	DATA
12	CLOCK
13	KEYBOARD GROUND
14	+5V

Wrg_0070A_4of5_104d_power_harness_internal

WIR-1012 (ASSEMBLY DRAWING WIR-1012)

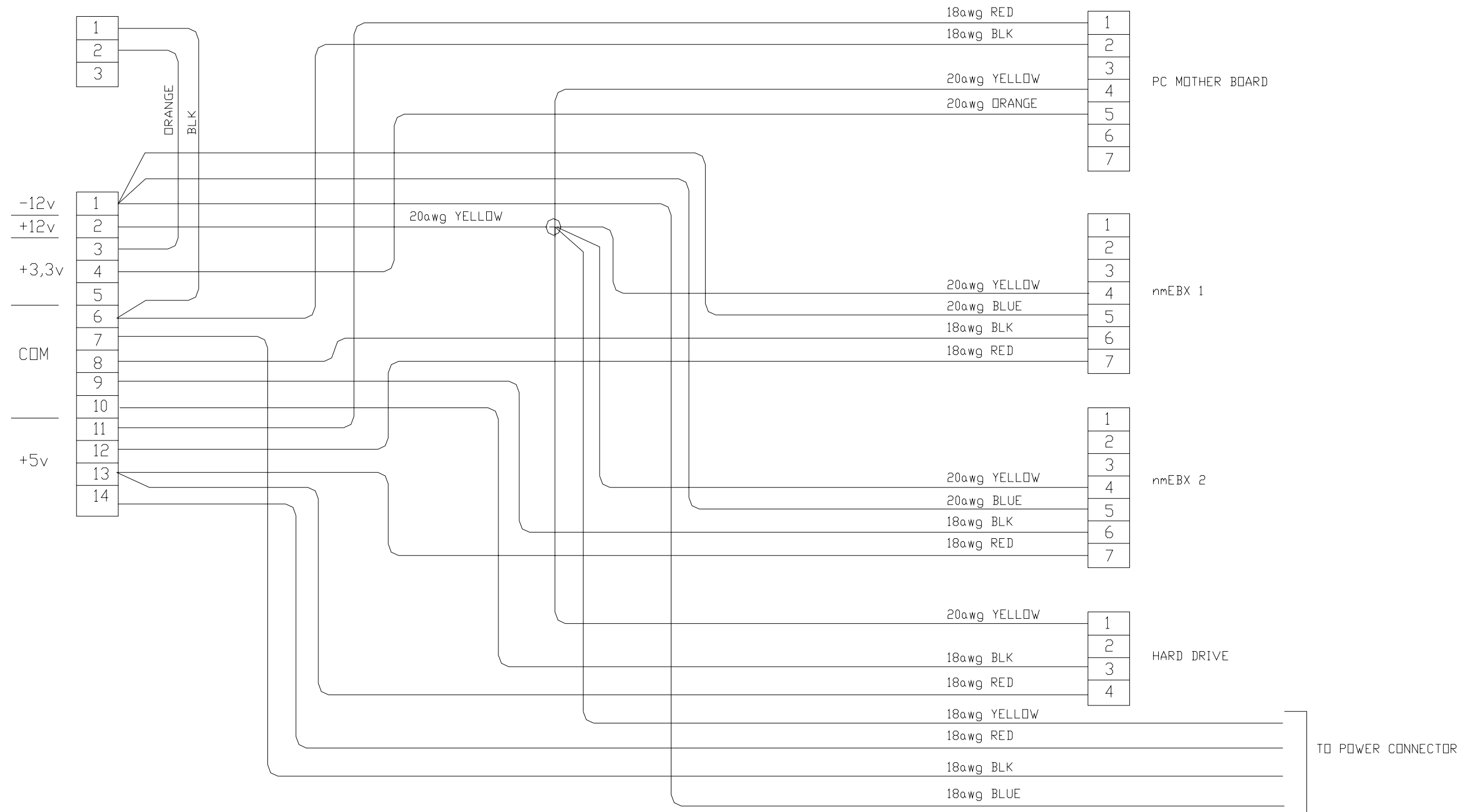

WIR-1024 (ASSEMBLY DRAWING WIR-1024)

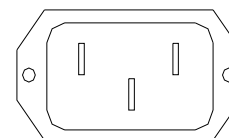
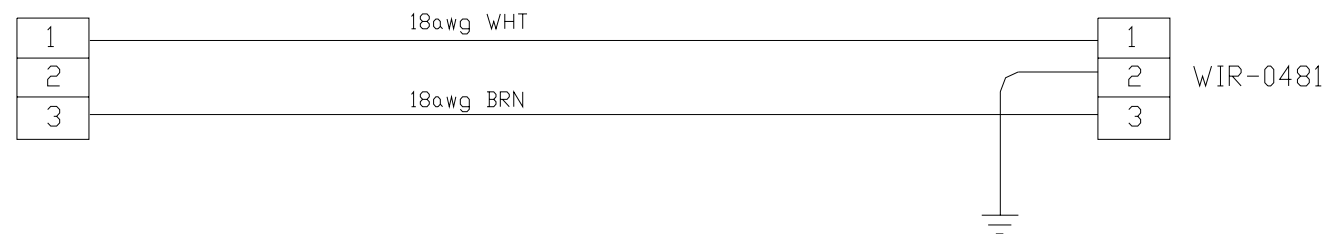

WRG_0074X_1of4_104d_control_cable

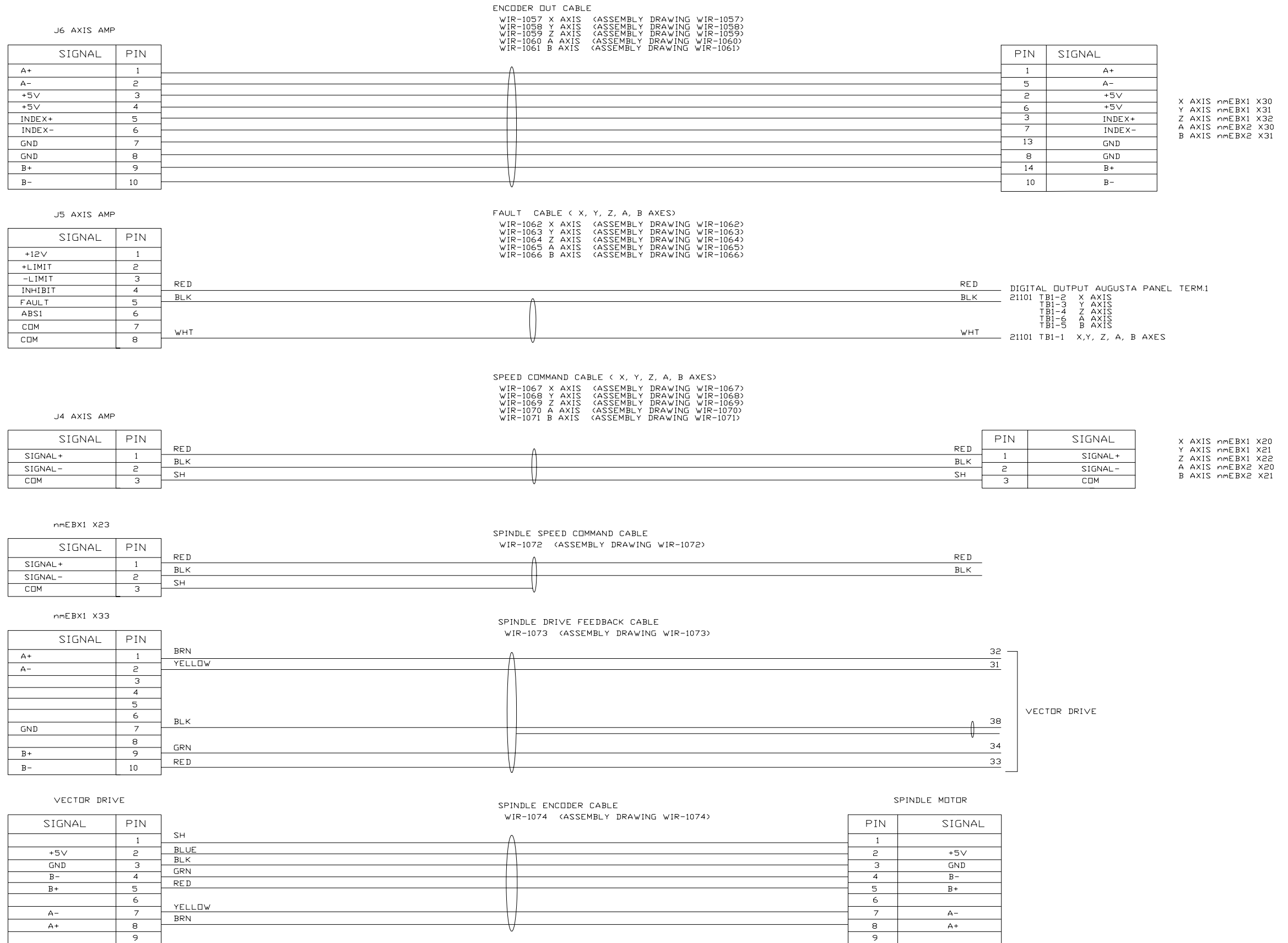

WRG_0074X_2of4_104d 21060 to 21101 21101 to 21102 cable

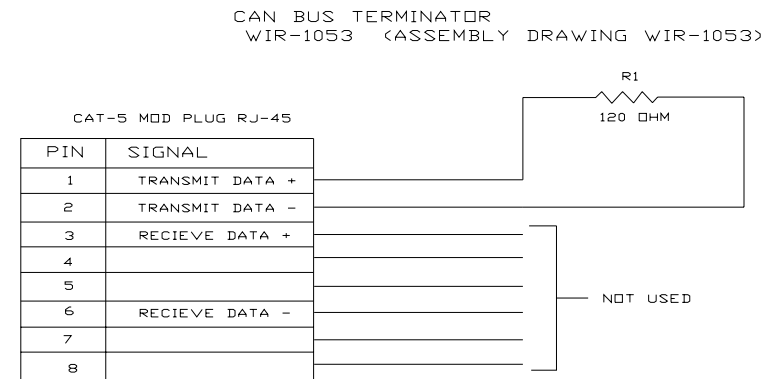
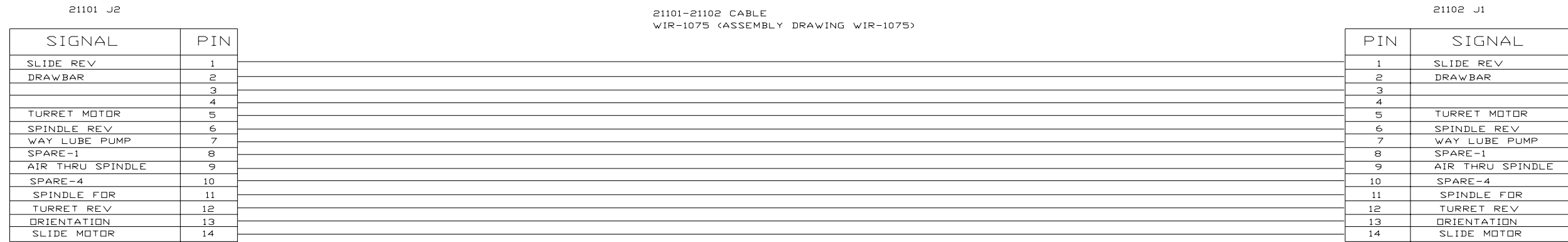
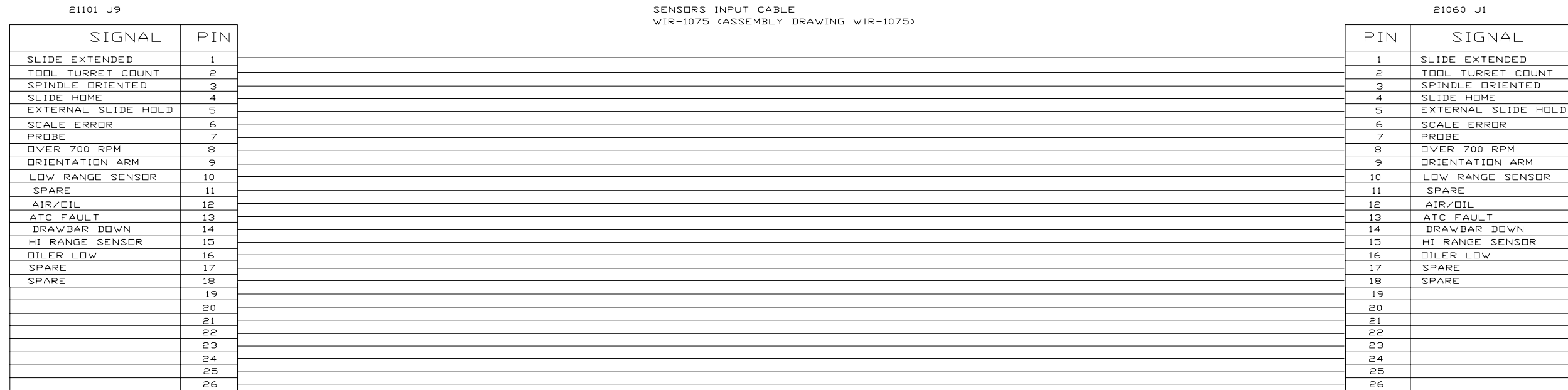

WRG_0074X_3of4_104d can vga usb cable

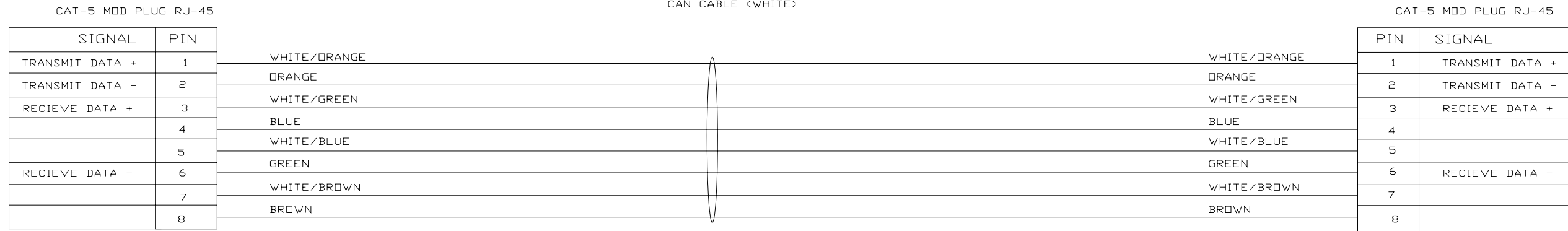

WIR-1077 AUGUSTA PANEL - 21101 J7 <ASSEMBLY DRAWING WIR-0077>
 WIR-1078 21101 J8 - 21550 J6 <ASSEMBLY DRAWING WIR-0078>
 WIR-1079 21550 J5 - 21330 J17 <ASSEMBLY DRAWING WIR-0079>
 WIR-1080 21330 J16 - INTERMIDIATION CONNECTION <ASSEMBLY DRAWING WIR-0080>
 WIR-1081 INTERMIDIATION CONNECTION - 21090 J7 <ASSEMBLY DRAWING WIR-0081>

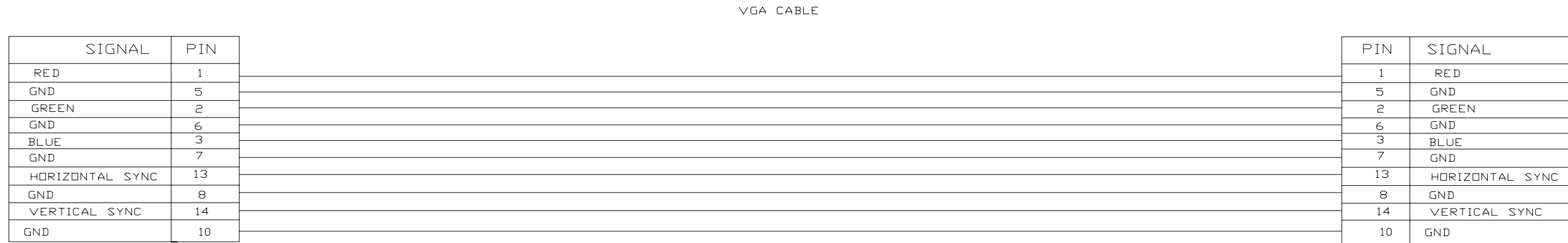

WIR-1082 AUGUSTA PANEL - INTERMEDIATE CONNECTION <ASSEMBLY DRAWING WIR-0082>
 WIR-1083 INTERMEDIATE CONNECTION - MONITOR <ASSEMBLY DRAWING WIR-0083>

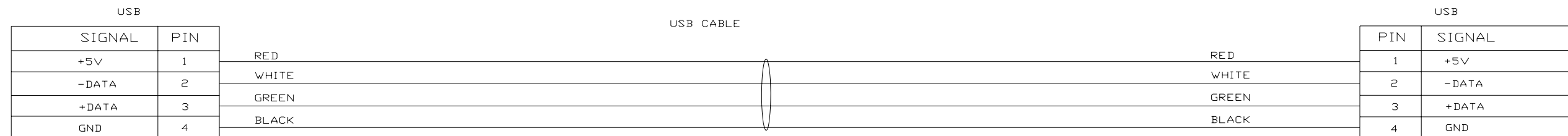

WIR-1084 AUGUSTA PANEL - INTERMEDIATE CONNECTION <ASSEMBLY DRAWING WIR-0084>
 WIR-1085 INTERMEDIATE CONNECTION - KEYBOARD <ASSEMBLY DRAWING WIR-0085>

WRG_0074X_4of4_104d motor signal power cable

AMP J7

X, Y, Z, A, B AXES SIGNAL CABLE
WIR-xxxx (ASSEMBLY DRAWING WIR-xxxx)

MOTOR SIGNAL

SIGNAL	PIN
A+	1
A-	2
+5V	3
+5V	4
M+	5
M-	6
COM	7
COM	8
B+	9
B-	10
ENCODER ERROR	11
nc	12
nc	13
U	14
V	15
W	16
TEMP	17
+5V	18
COM	19
SHIELD	20

PIN	SIGNAL
F	A+
G	A-
S	+5V FOR ENCODER
V	+5V FOR ENCODER
U	M+
K	M-
E	COM FOR ENCODER
R	COM FOR ENCODER
H	B+
J	B-
T	ENCODER ERROR
M	HALL U
A	HALL V
B	HALL W
L	TEMP
N	+5V FOR HALL
P	COM FOR HALL
C	ENCODER SHIELD
D	HALL SHIELD

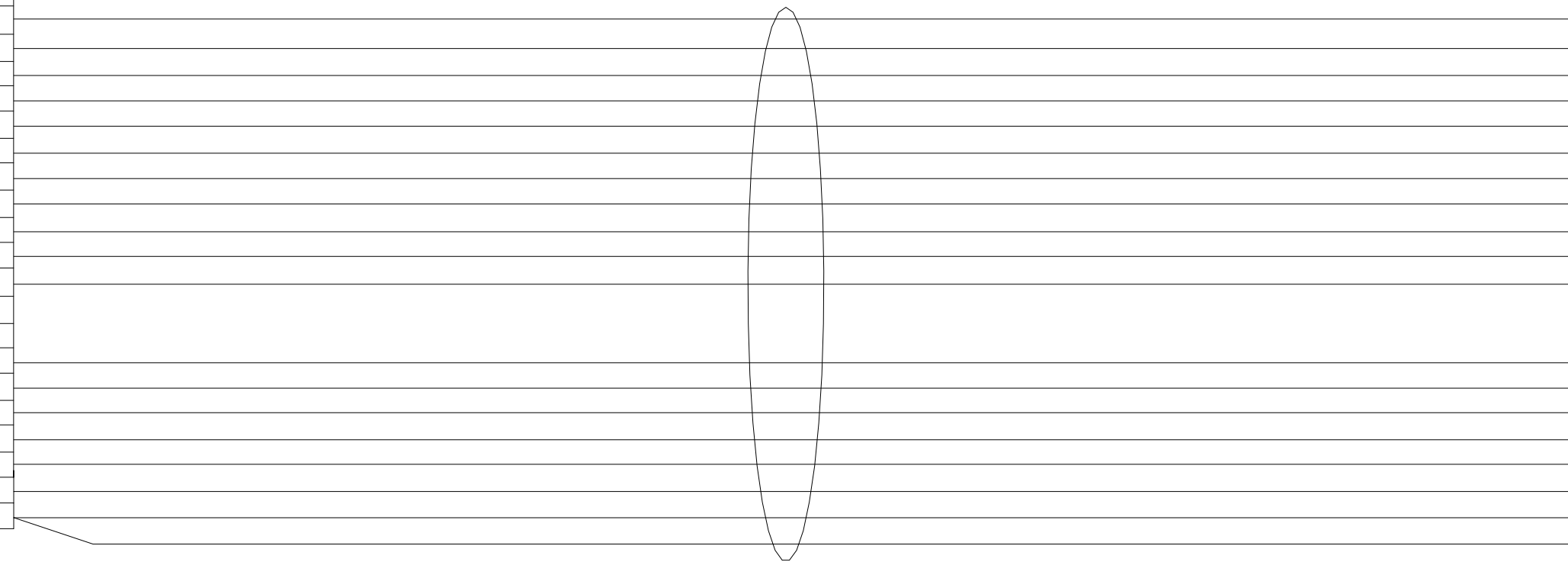

X, Y, Z, A, B AXES POWER CABLE
WIR-xxxx (ASSEMBLY DRAWING WIR-xxxx)

MOTOR POWER

RED
WHT
BLK
GRN/YELLOW

PIN	SIGNAL
A	PHASE R
B	PHASE S
C	PHASE T
D	GND
E	NC

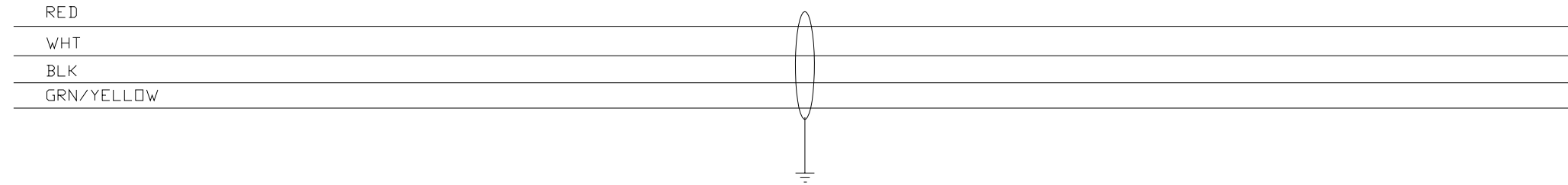

WRG_0075X_1of6_104D_trans240

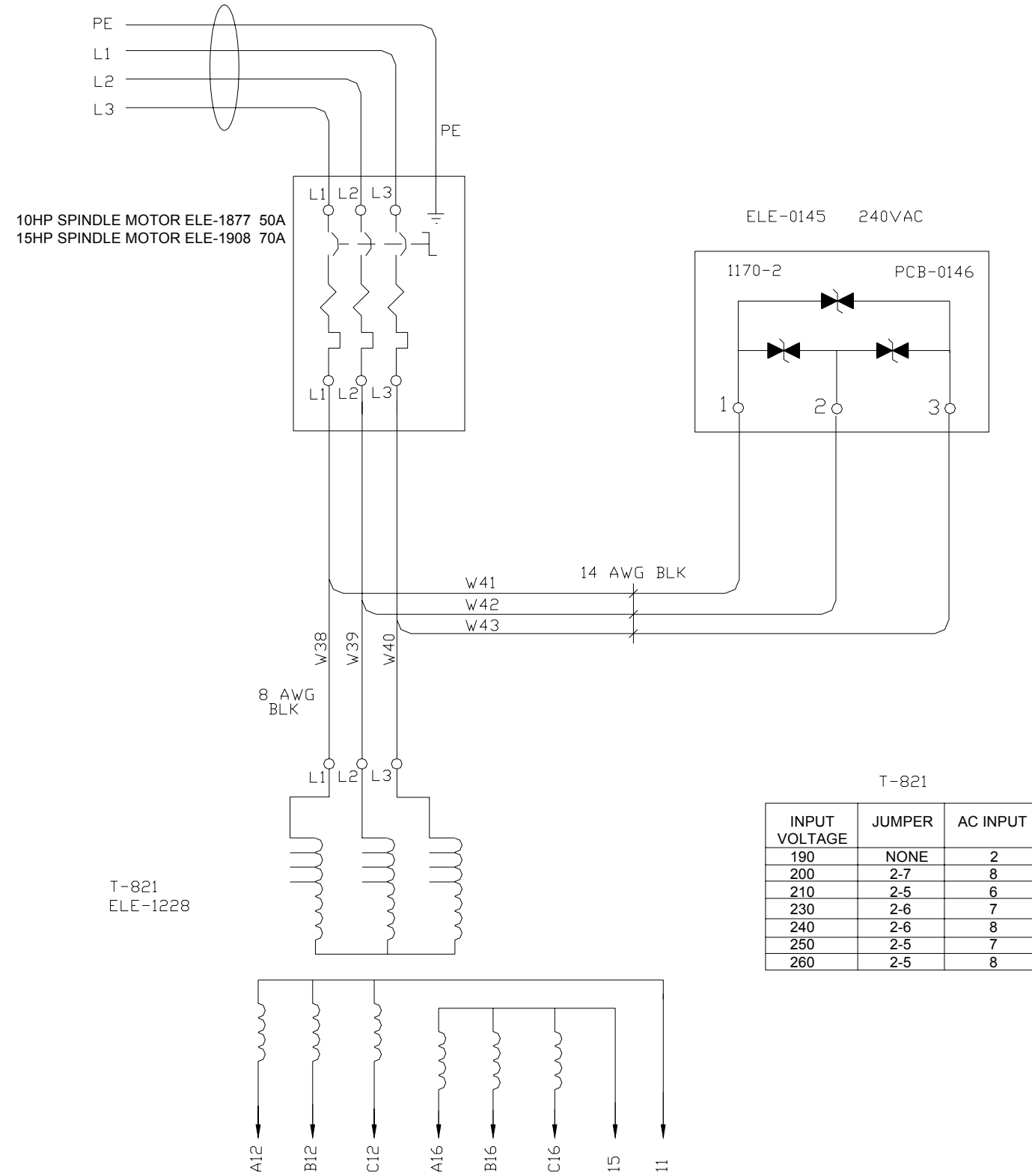

T-821

INPUT VOLTAGE	JUMPER	AC INPUT
190	NONE	2
200	2-7	8
210	2-5	6
230	2-6	7
240	2-6	8
250	2-5	7
260	2-5	8

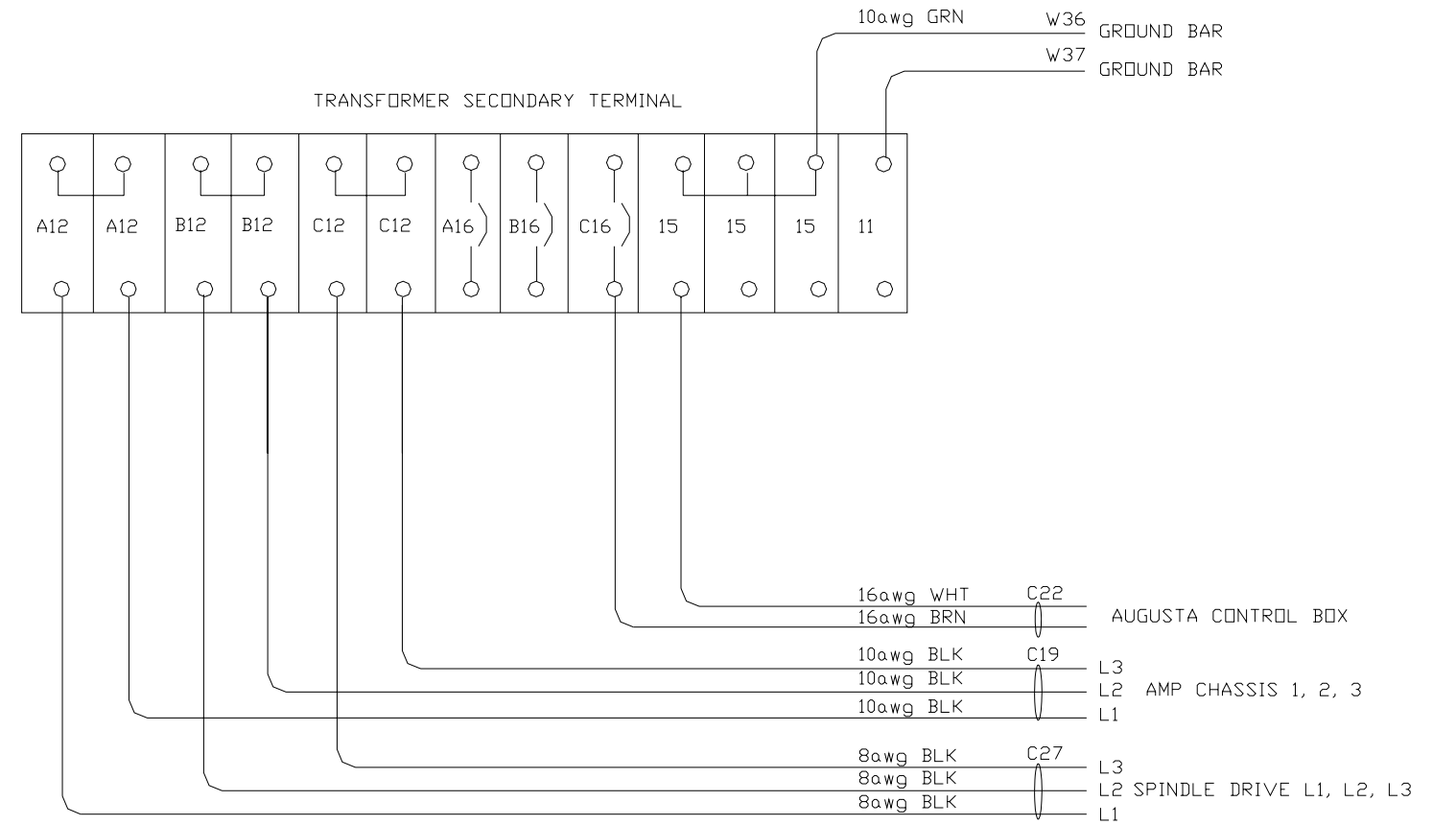

WRG_0075X_2of6_104D_trans480

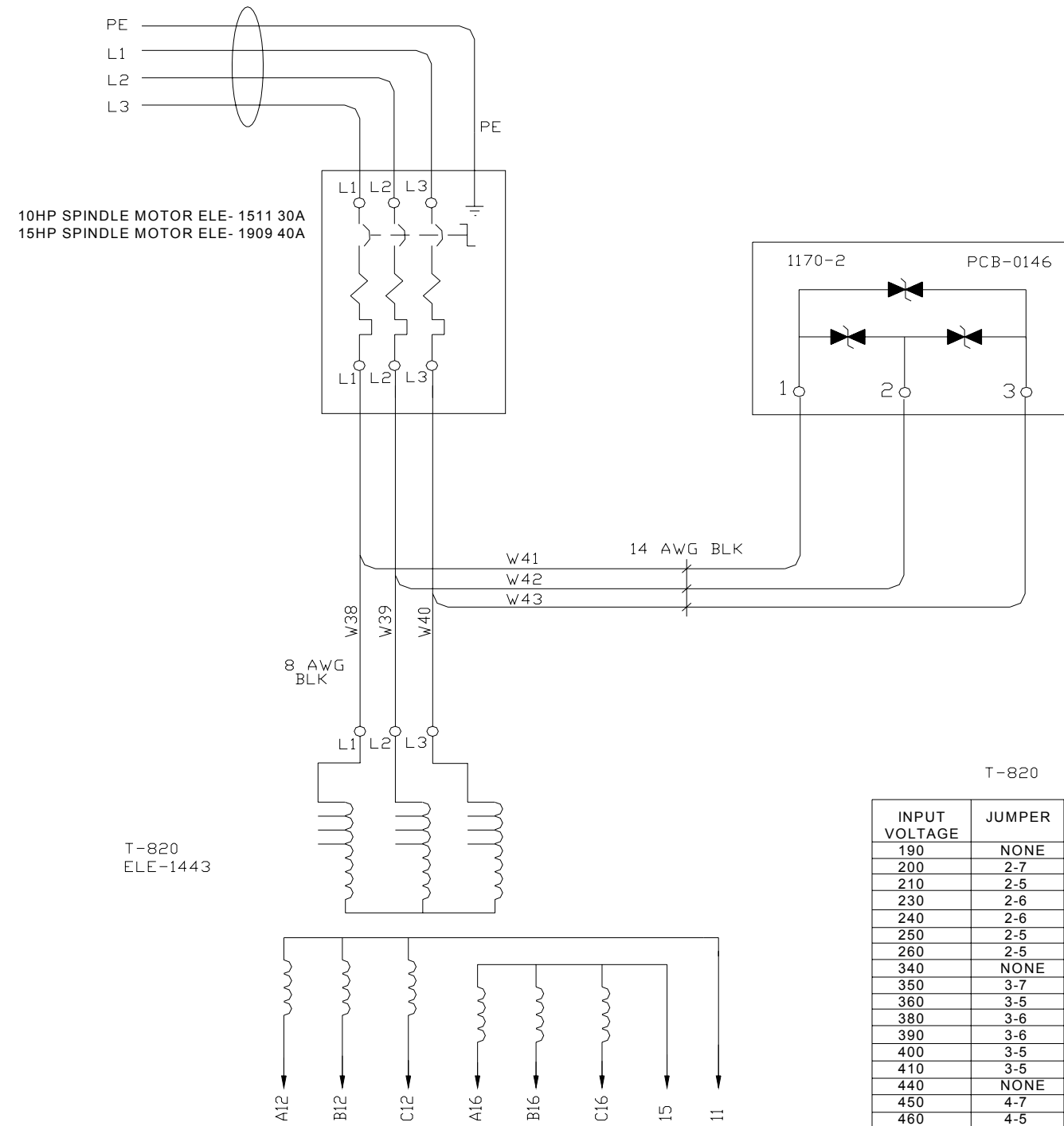

T-820

INPUT VOLTAGE	JUMPER	AC INPUT
190	NONE	2
200	2-7	8
210	2-5	6
230	2-6	7
240	2-6	8
250	2-5	7
260	2-5	8
340	NONE	3
350	3-7	8
360	3-5	6
380	3-6	7
390	3-6	8
400	3-5	7
410	3-5	8
440	NONE	4
450	4-7	8
460	4-5	6
480	4-6	7
490	4-6	8
500	4-5	7
501	4-5	8

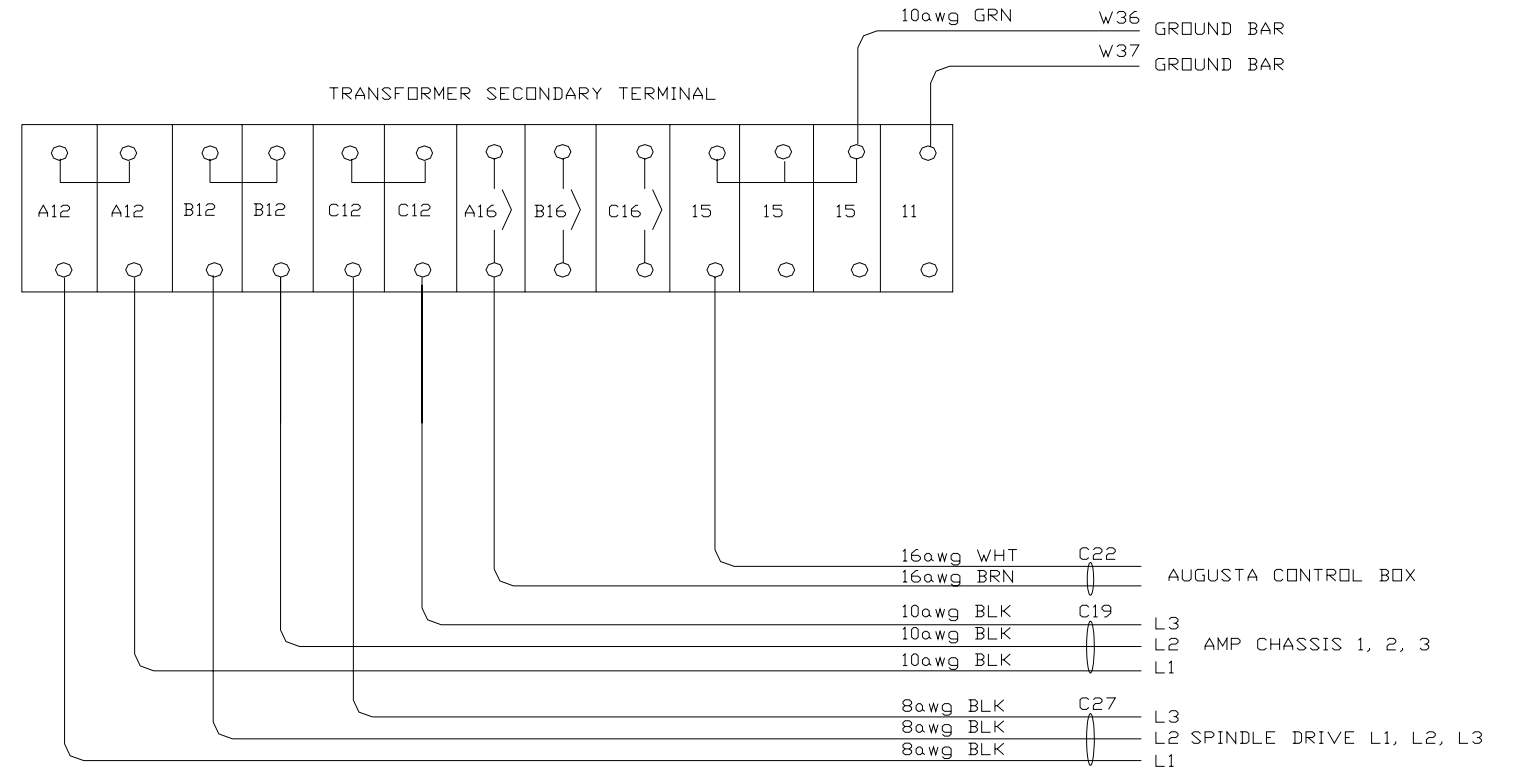

WRG_0075X_3of6_104D_transVHT

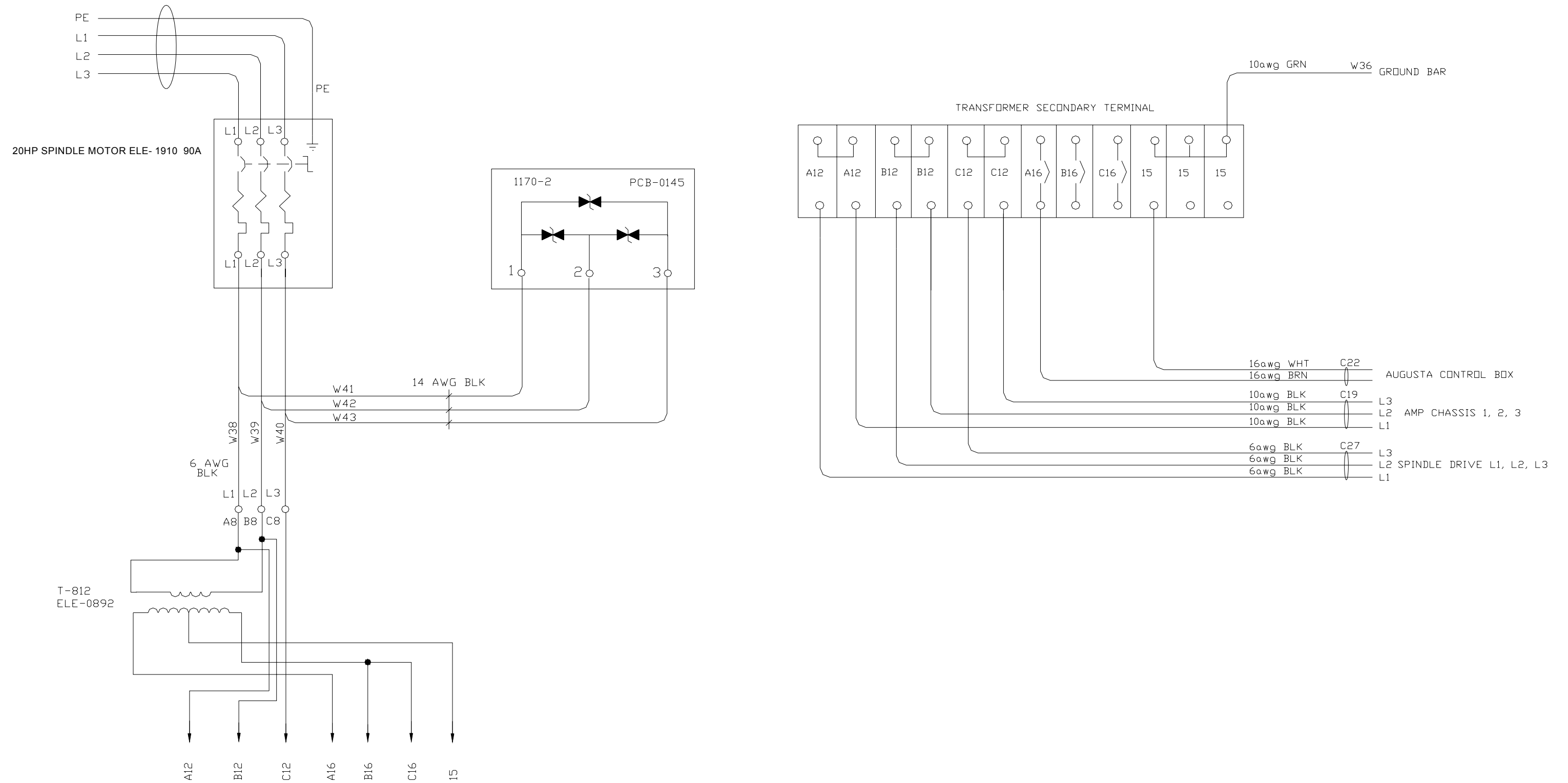

WRG_0075X_4of6_104D_transCE

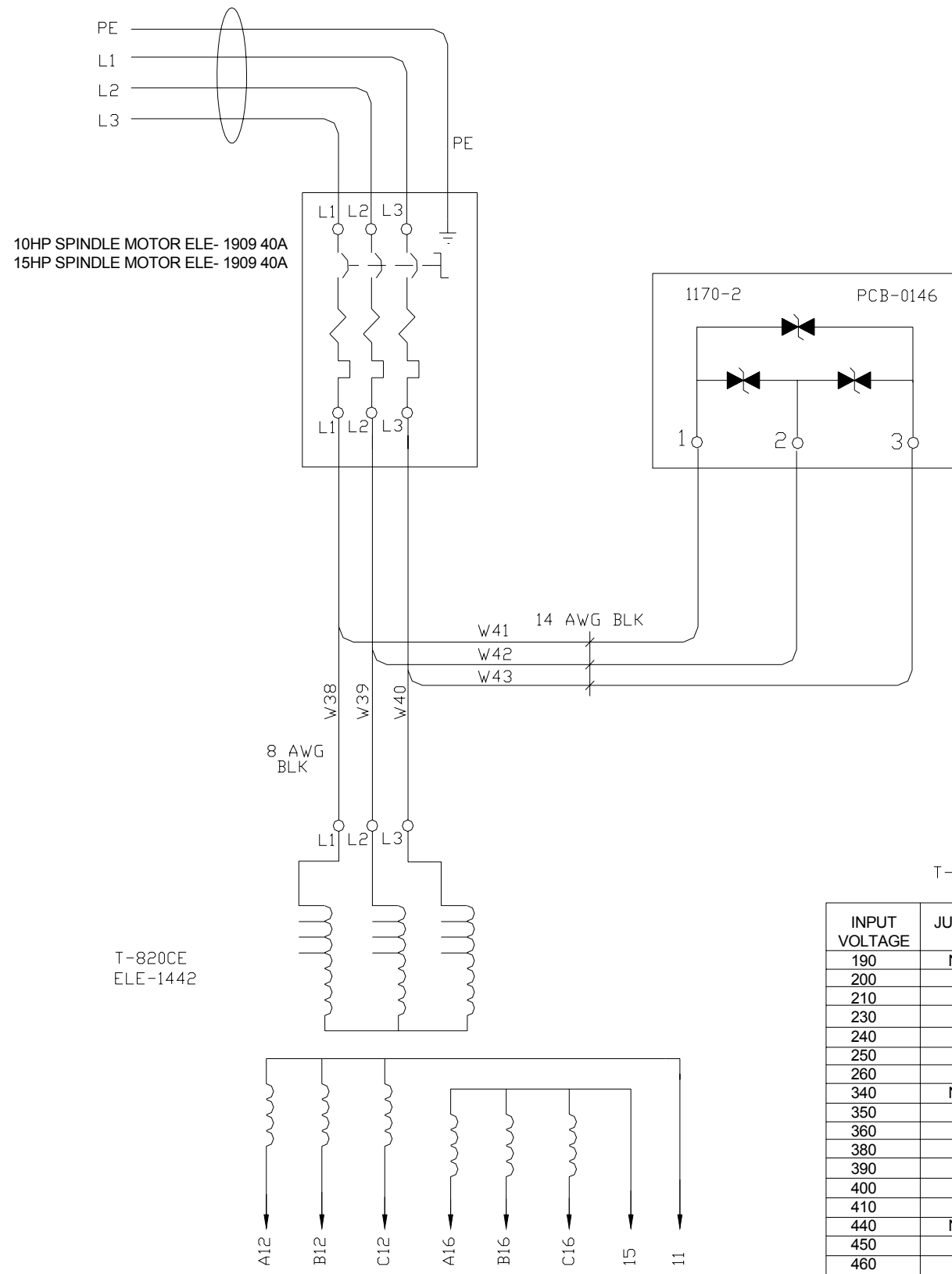

T-820

INPUT VOLTAGE	JUMPER	AC INPUT
190	NONE	2
200	2-7	8
210	2-5	6
230	2-6	7
240	2-6	8
250	2-5	7
260	2-5	8
340	NONE	3
350	3-7	8
360	3-5	6
380	3-6	7
390	3-6	8
400	3-5	7
410	3-5	8
440	NONE	4
450	4-7	8
460	4-5	6
480	4-6	7
490	4-6	8
500	4-5	7
501	4-5	8

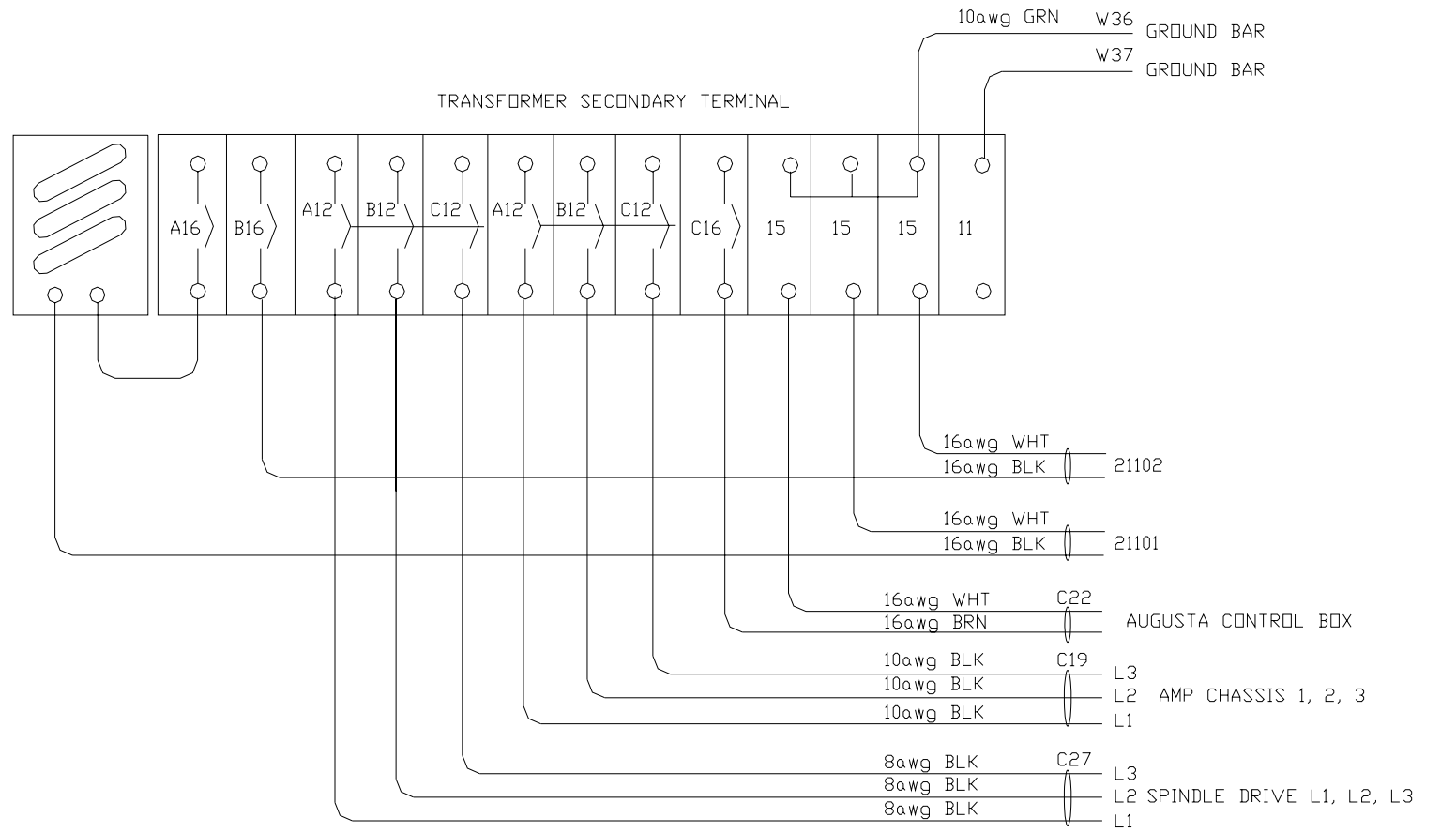

WRG_0075X_5of6_104D_transVHTCE

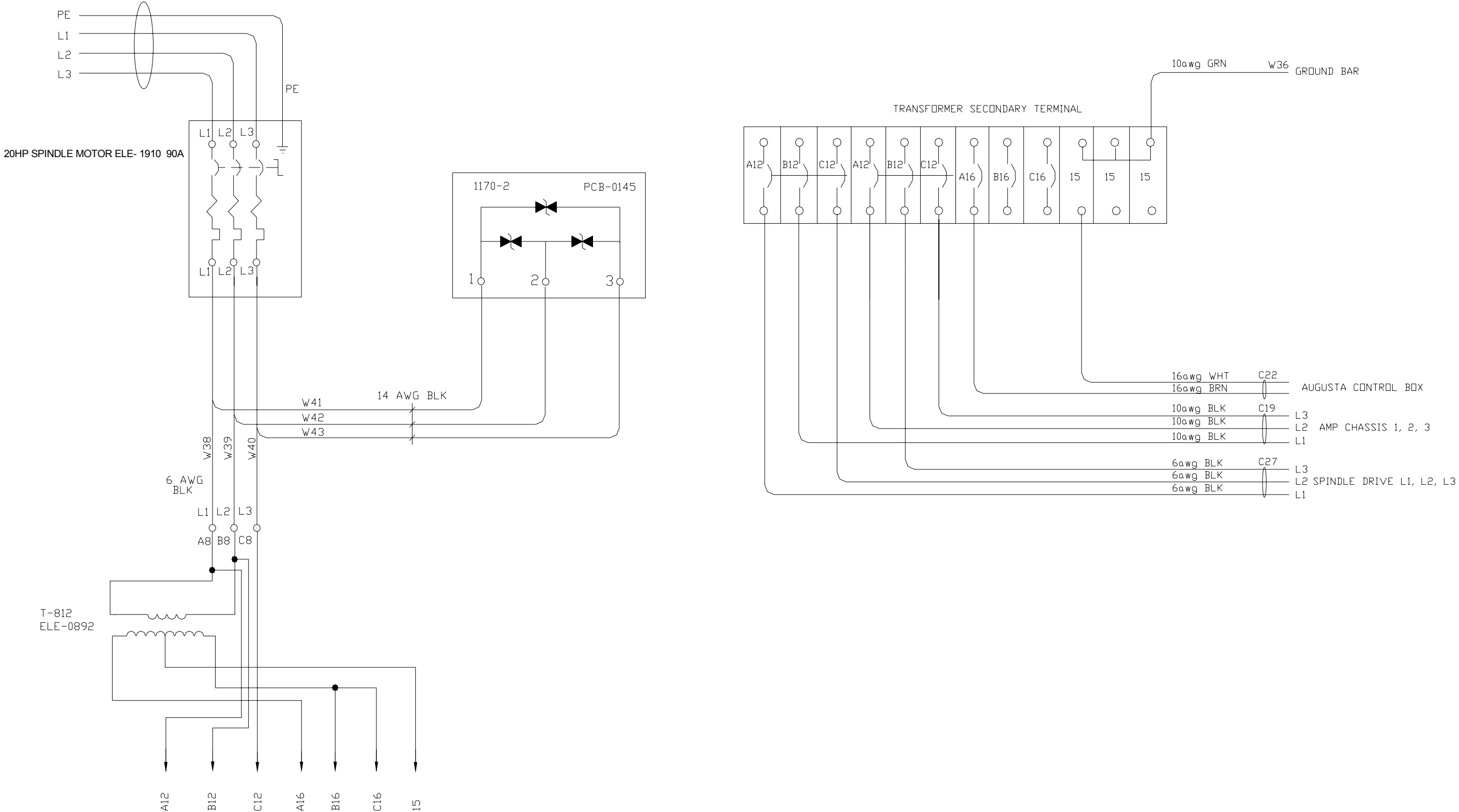

WRG_0075X_6of6_104D_trans_single_ph

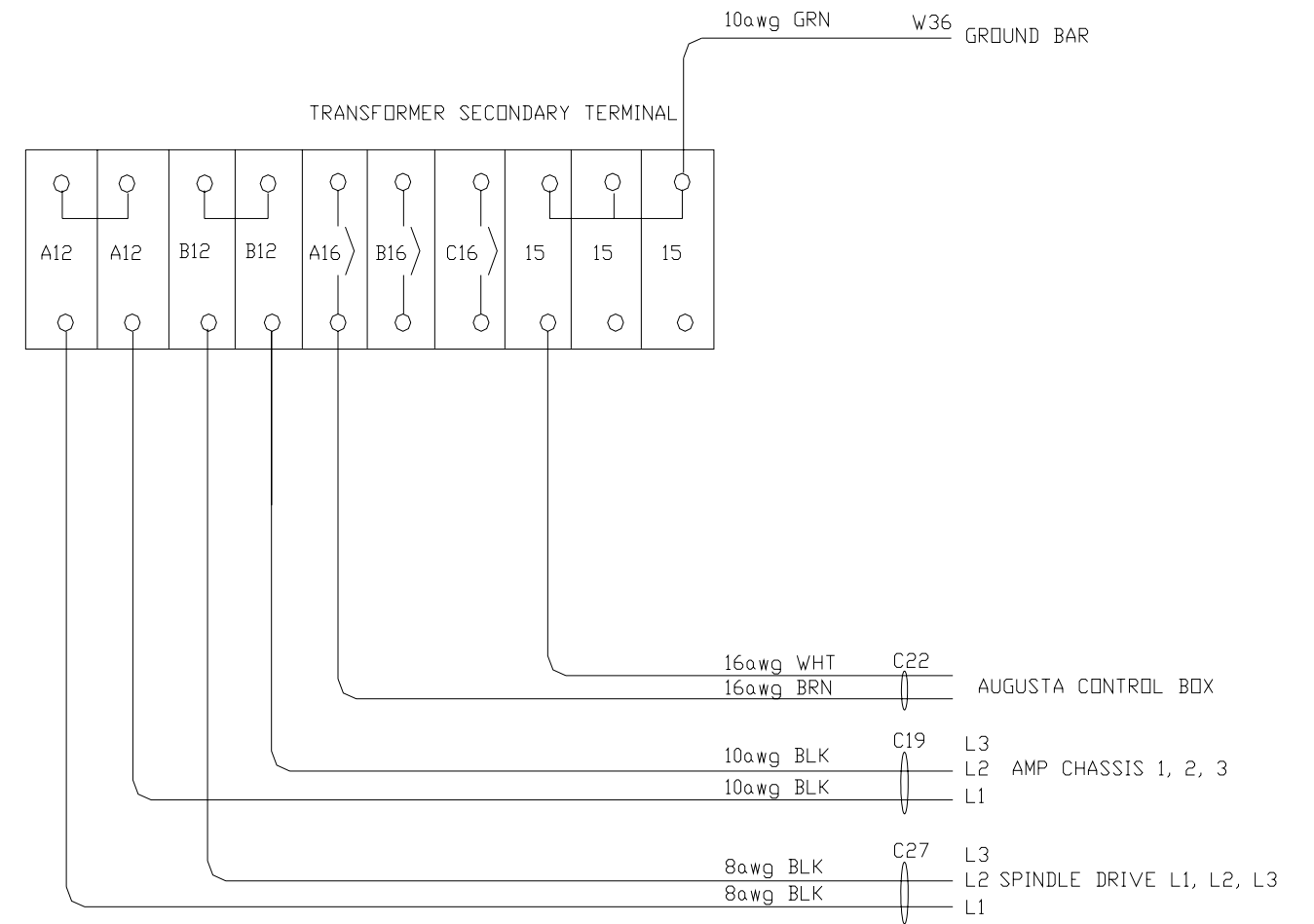
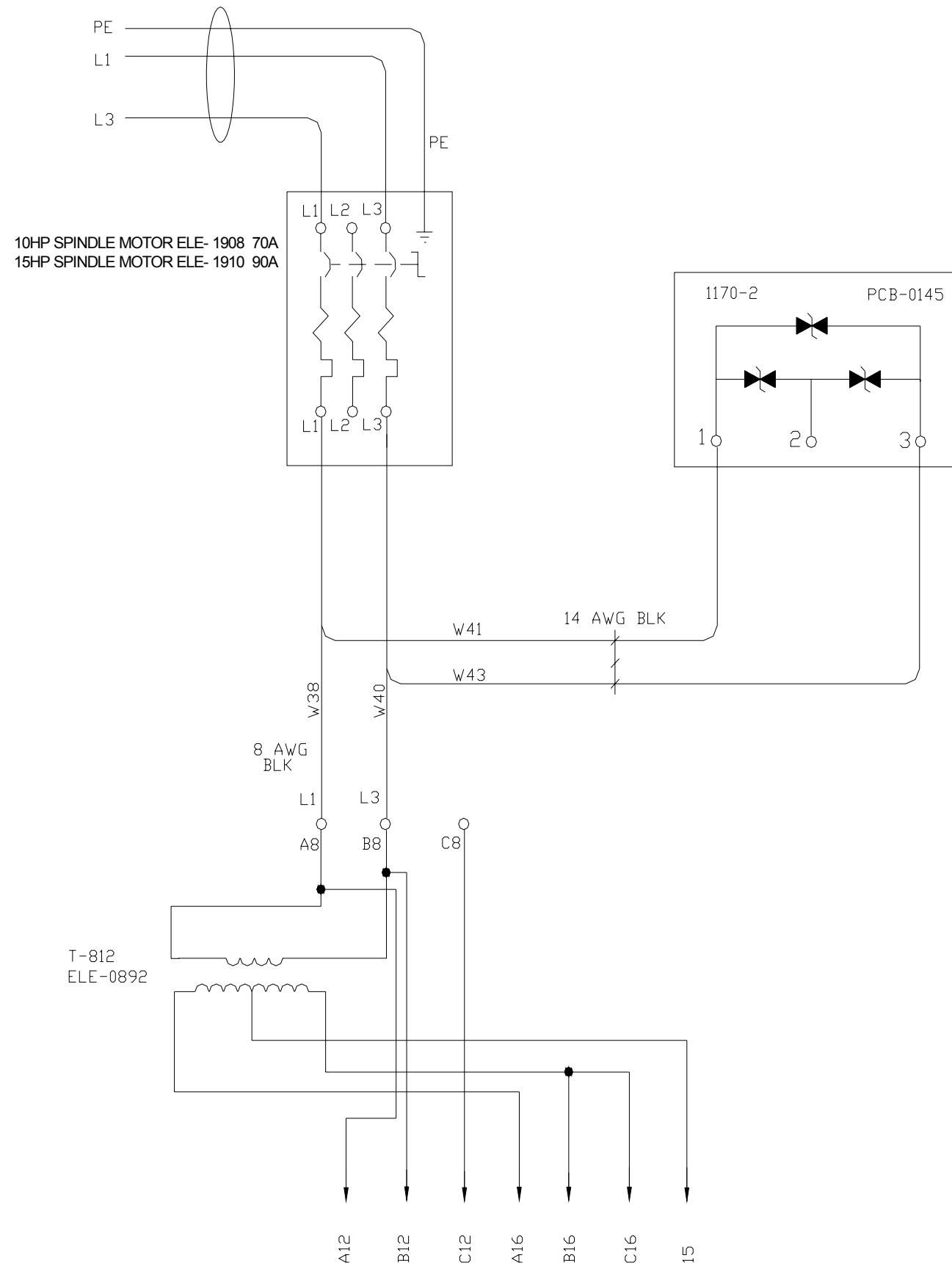

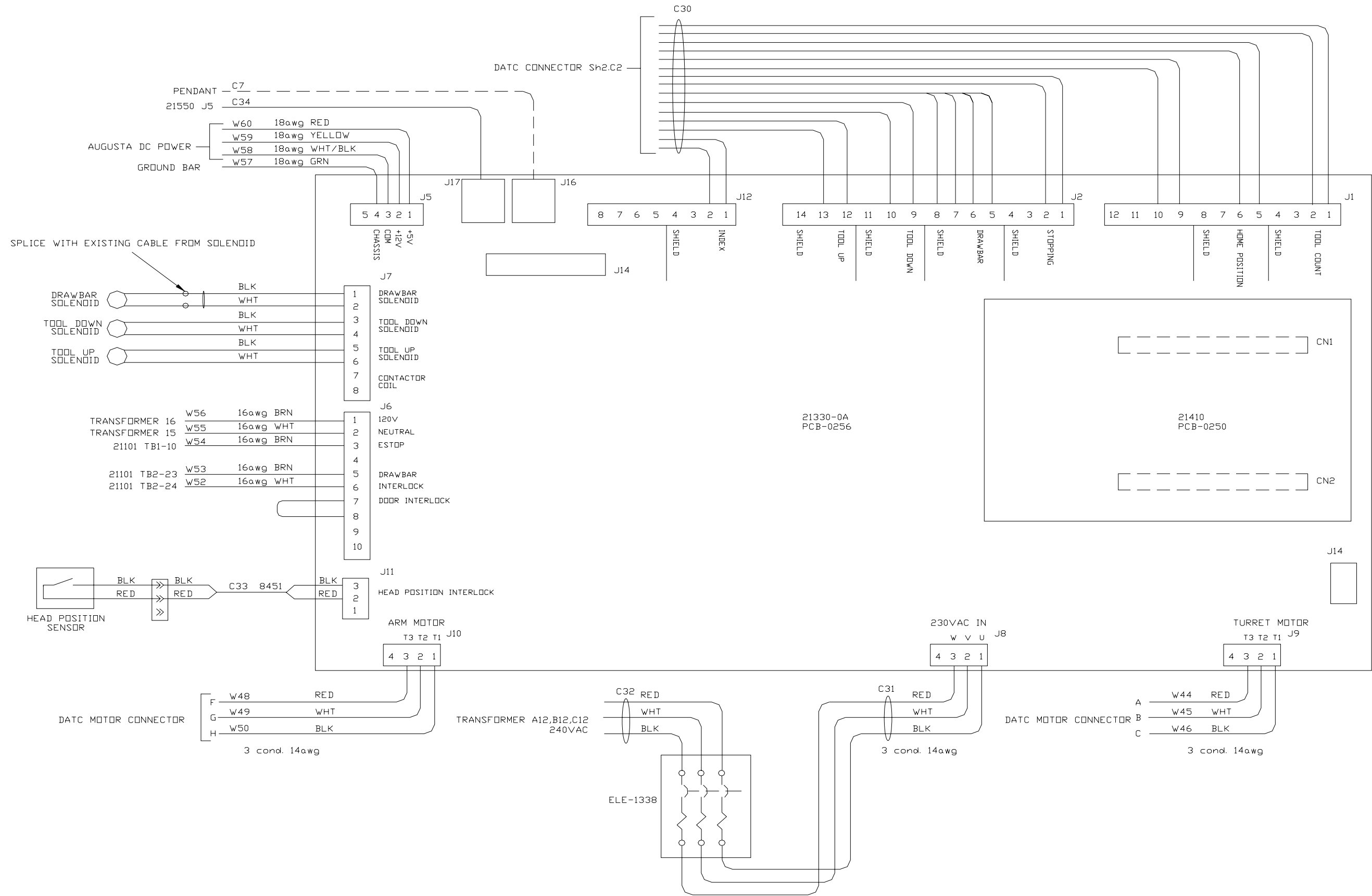

NOTE: UNNAMED WIRES AND CABLES BELONG TO DATC HARNESS

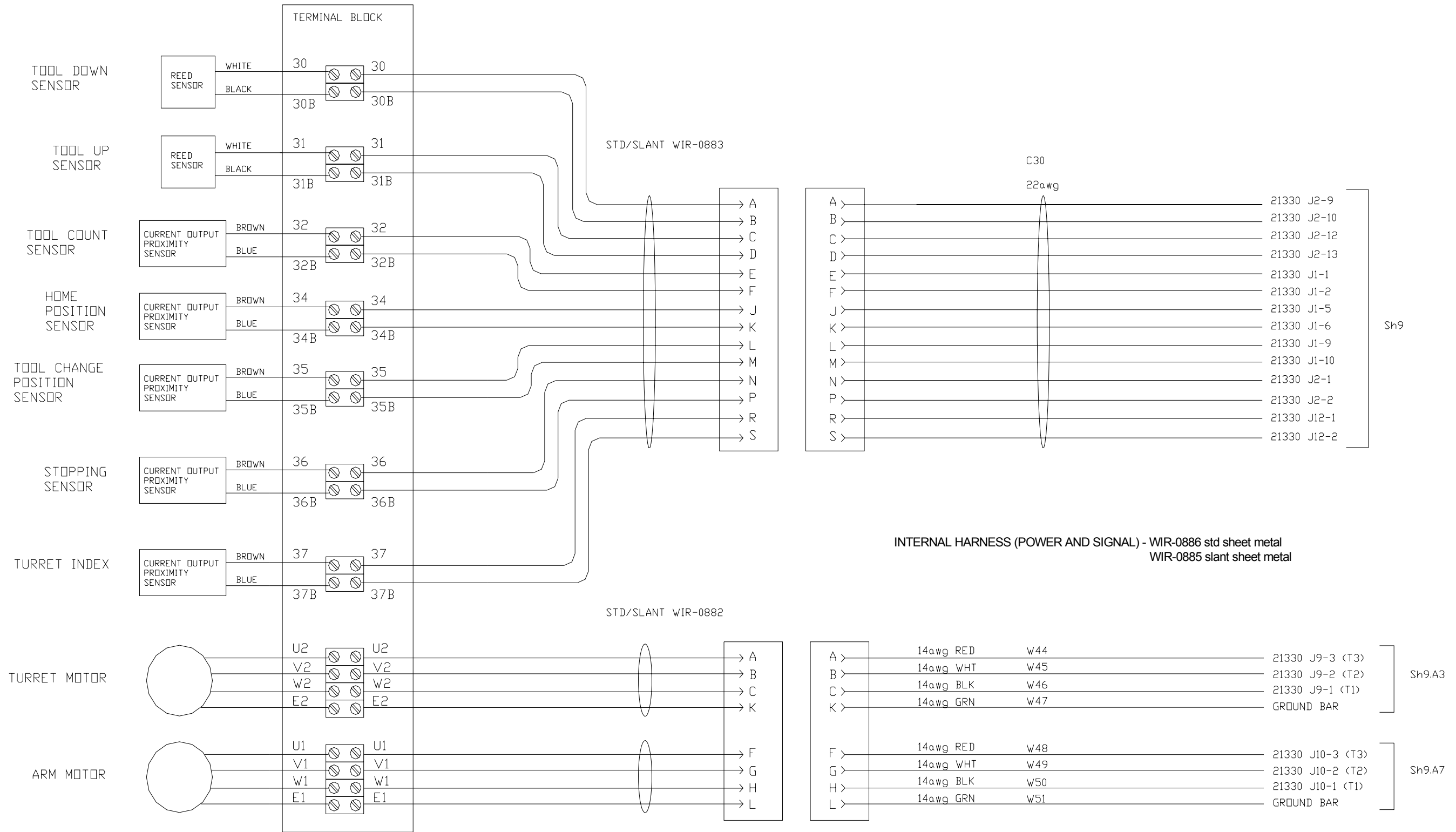

NOTE: - TOOL CHANGER JUNCTION BOX IS MOUNTED ON TOOL CHANGER.

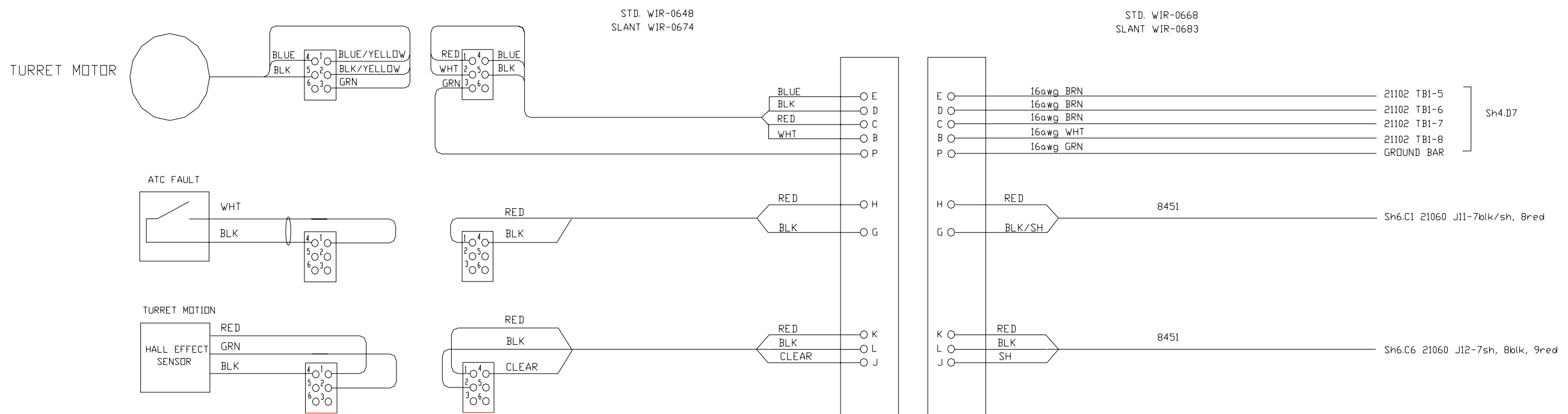
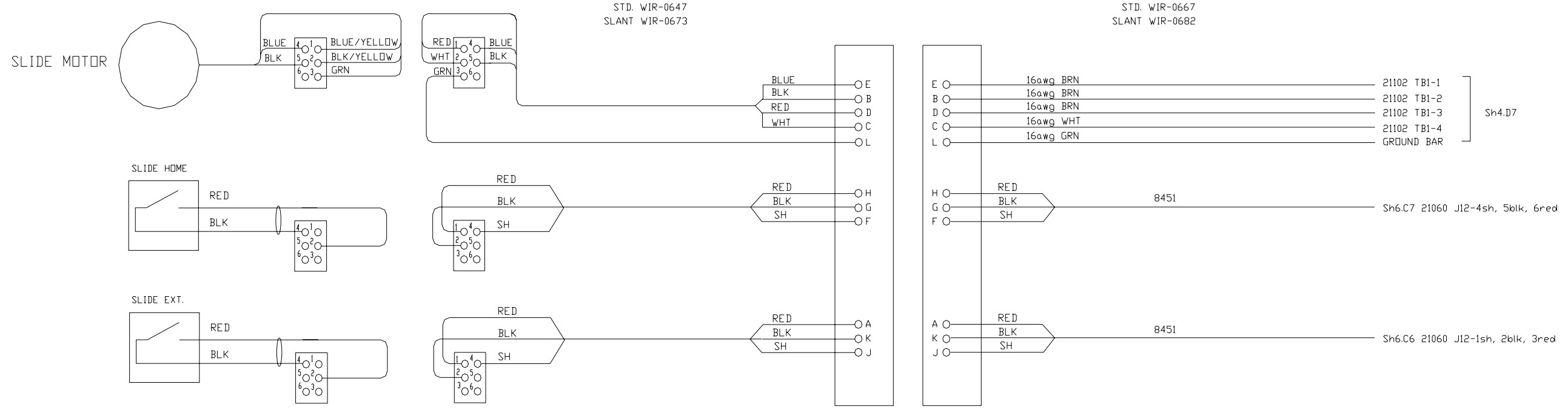

WRG_0079X_104D_spindle_drive

BALDOR VECTOR DRIVE

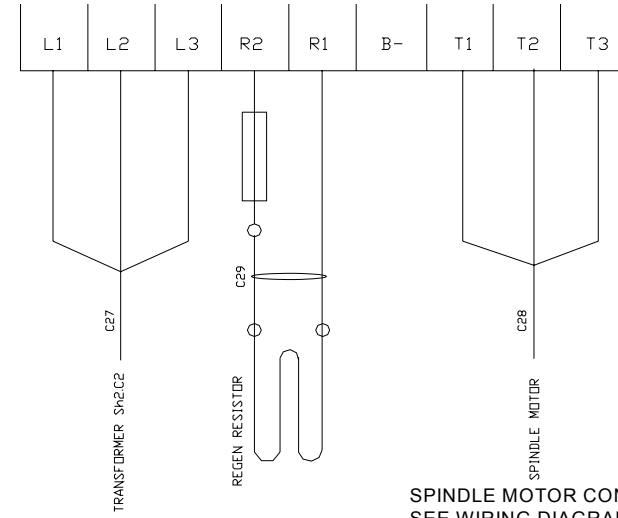
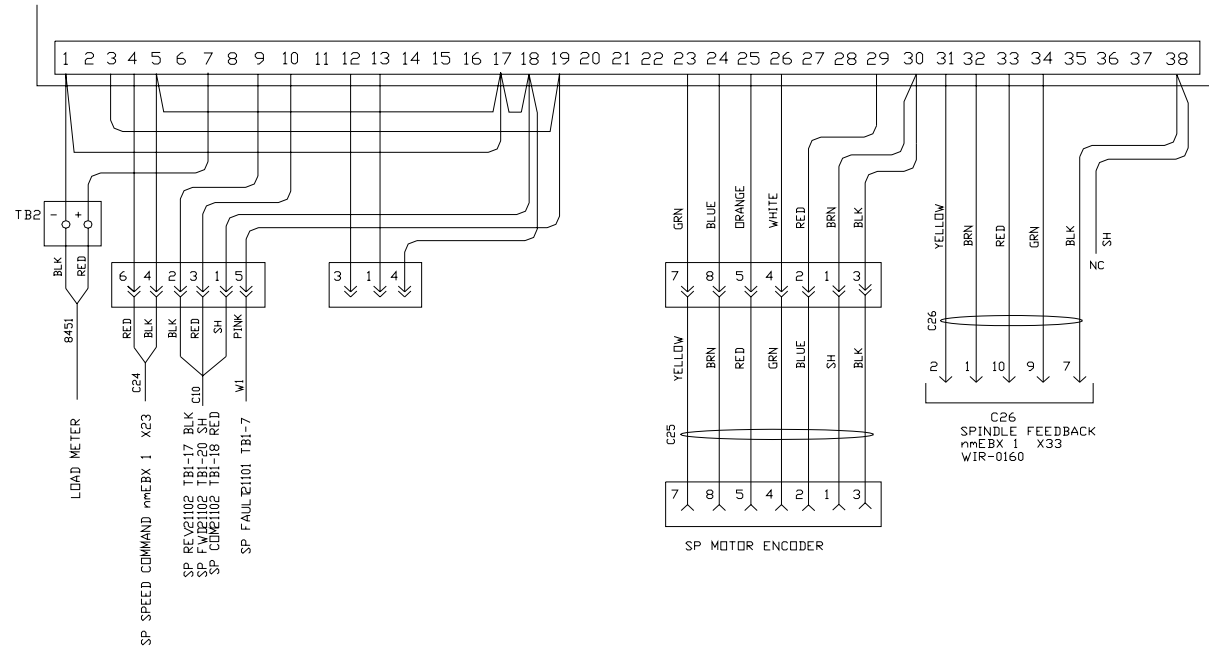

VMC-2016L, 3016L, 2216
3016, 4020 STD 10000 RPM **INV-0041**
VMC-2216, 3016, 3020, 4020
4525, 6030, 8030 10000 RPM **INV-0020**

SPINDLE MOTOR CONNECTIONS
SEE WIRING DIAGRAMS: WRG-0023(WYE DELTA)
WRG-0024

AMC VECTOR DRIVE

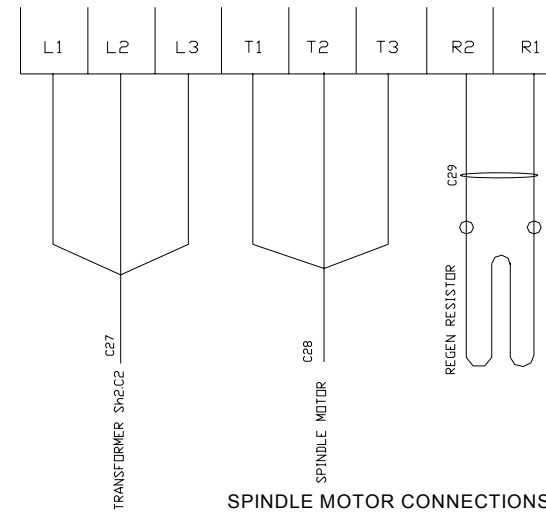
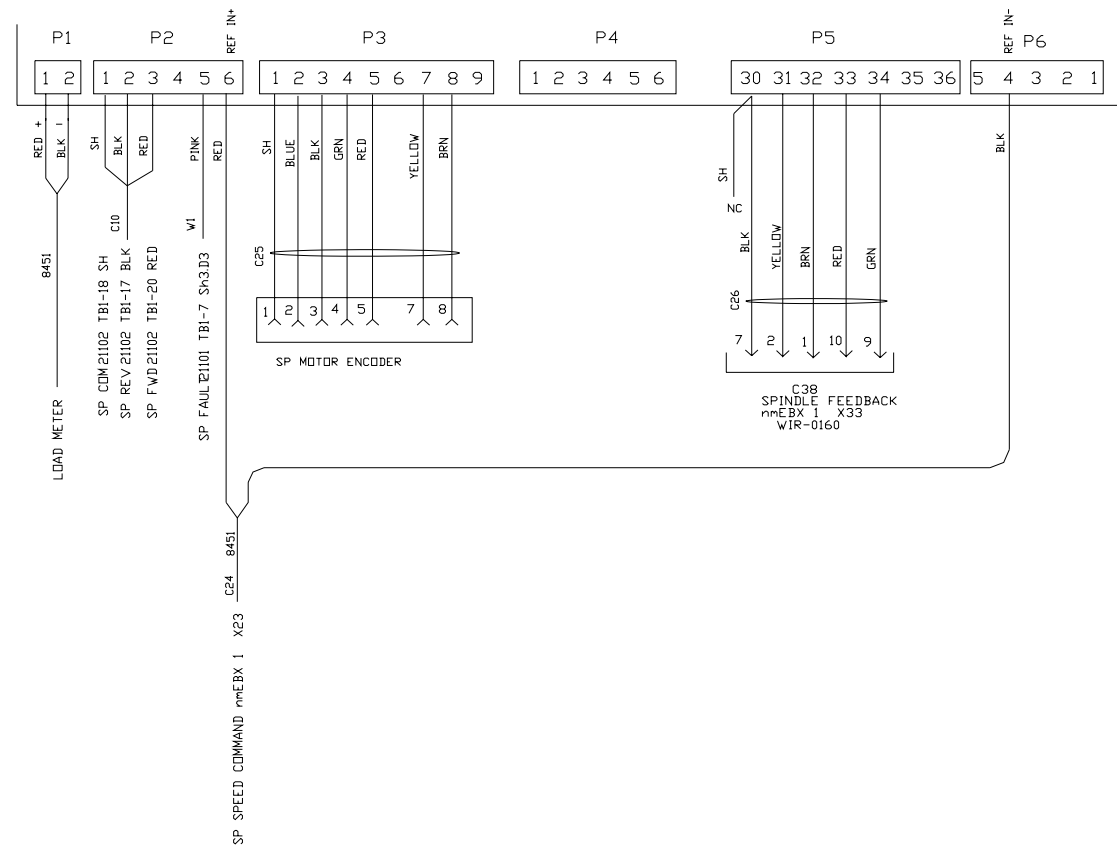

VMC-2216, 3016, 3020, 4020
4525, 6030, 8030 10000 RPM **INV-0056**

SPINDLE MOTOR CONNECTIONS
SEE WIRING DIAGRAMS: WRG-0023(WYE DELTA)
WRG-0024

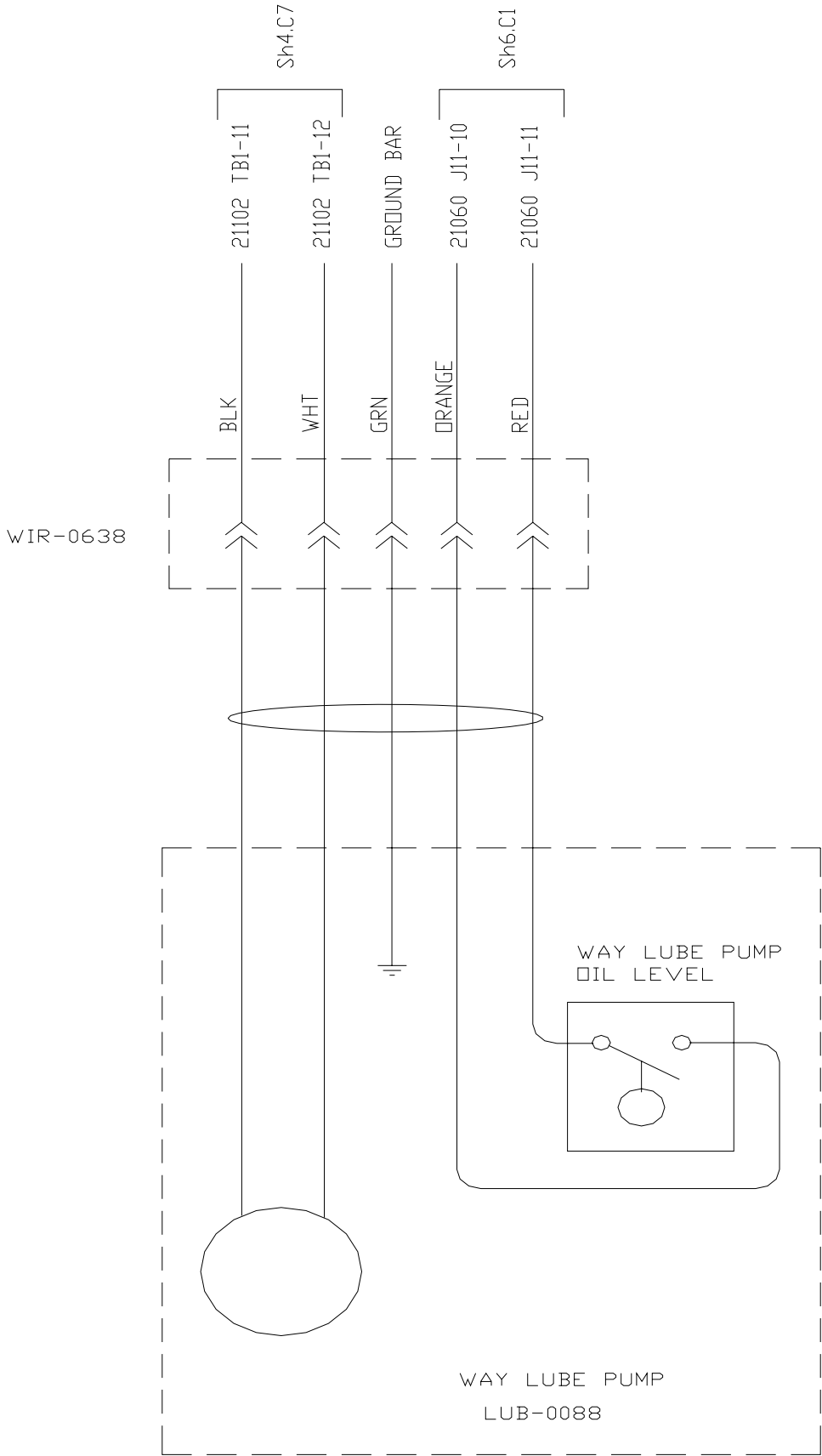

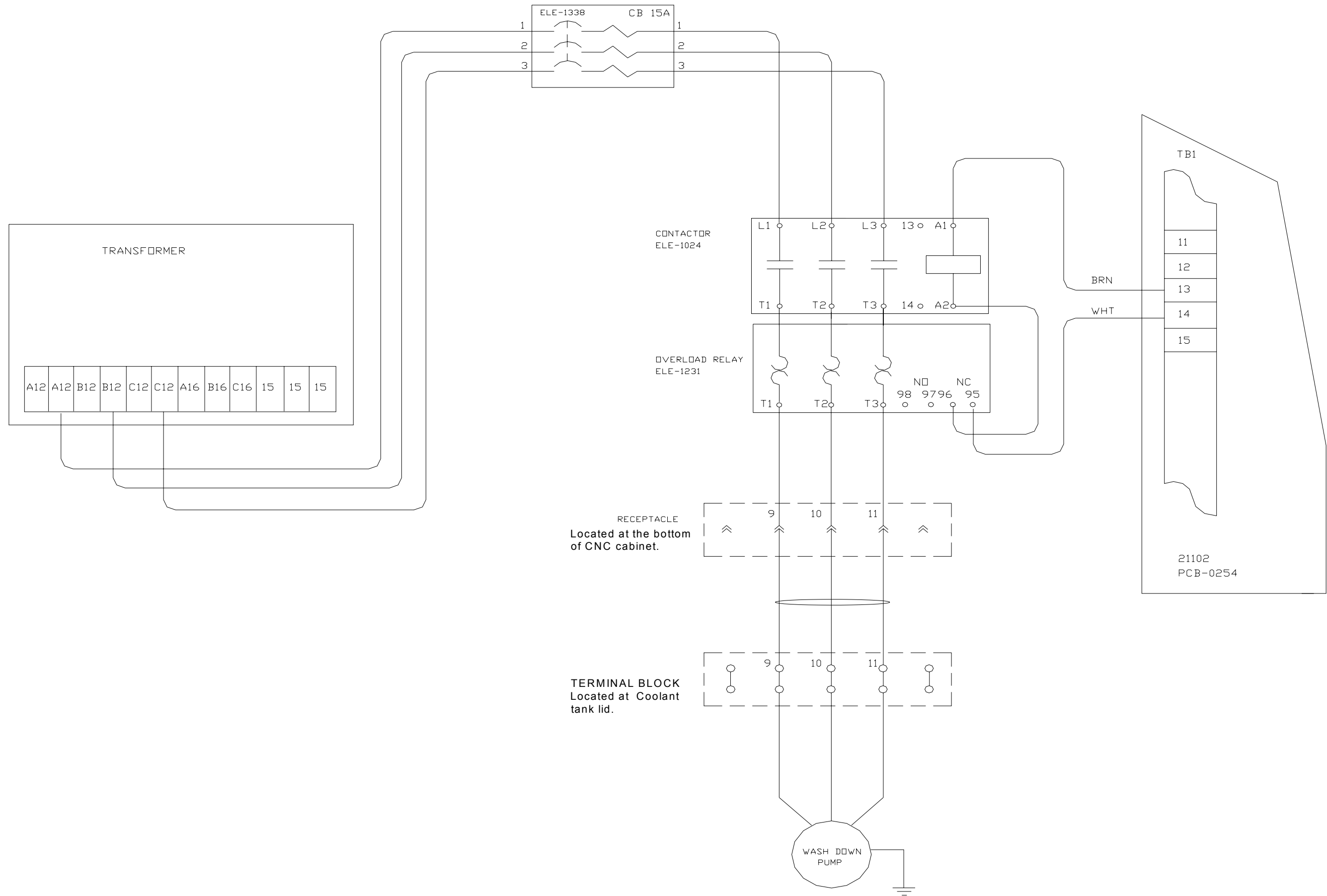

WRG_0083A_sht1of2_104D_US wiring_Hennig_Chip_Conveyor

PARTS LIST IN ELECTRICAL CABINET:

Contactors:

ABB B6-30-10, 120VDC coil ELE-1299
 Circuit Breaker, 15A QOU315, ELE-1338
 DIN Rail HDW-0668

Relay and Socket:

Omron MY4N, 120 VAC, ELE-0072
 Omron PYF14A-E, ELE-1440

Receptacle:

Hubble HBL-4560 or equiv. ELE-0815
 (250V 2-phase, twist-lock)
 Receptacle is located where
 auger receptacle went.

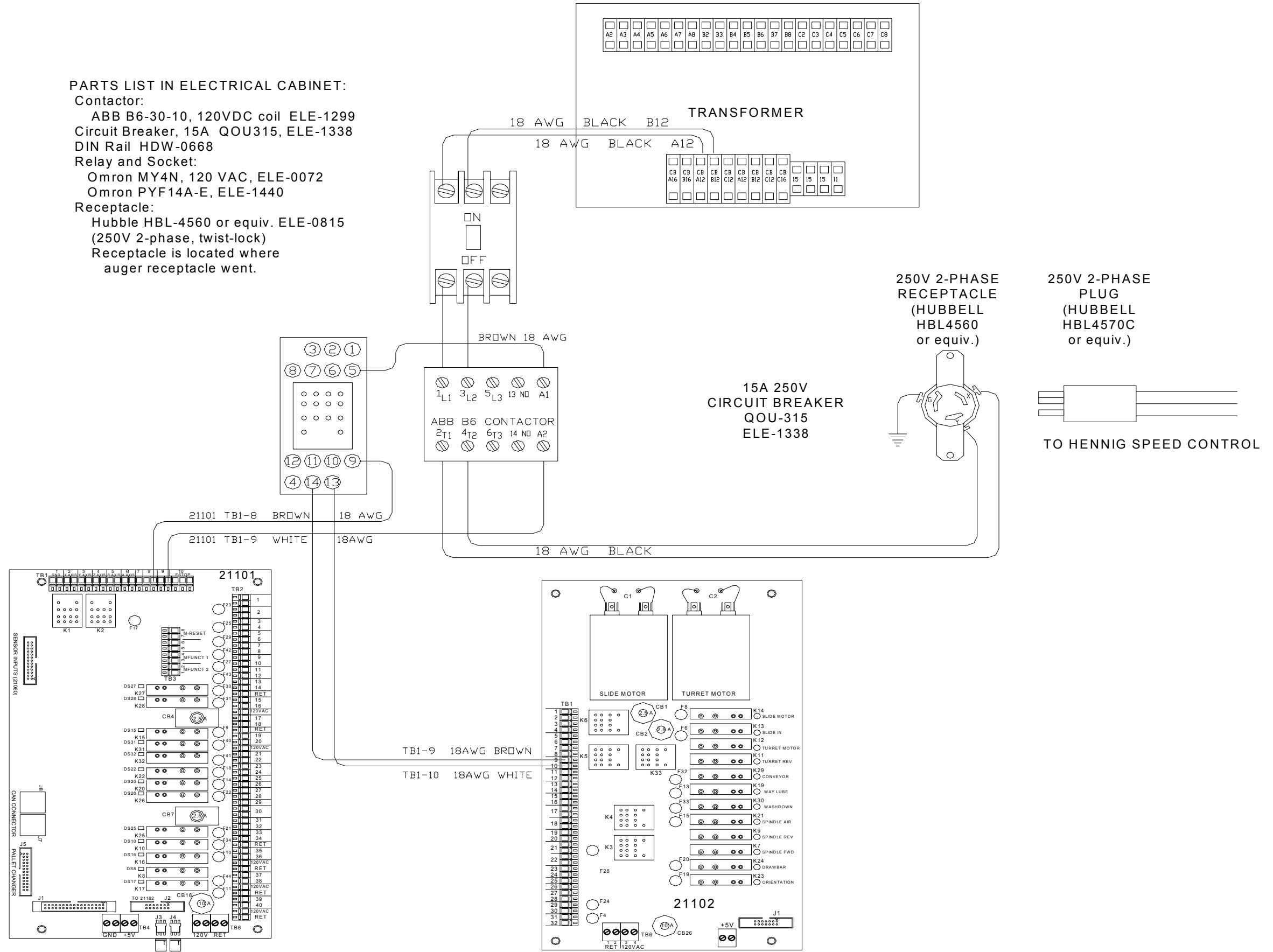

WRG_0083A_sht2of2_CE_wiring_Hennig_Chip_Conveyor 104D

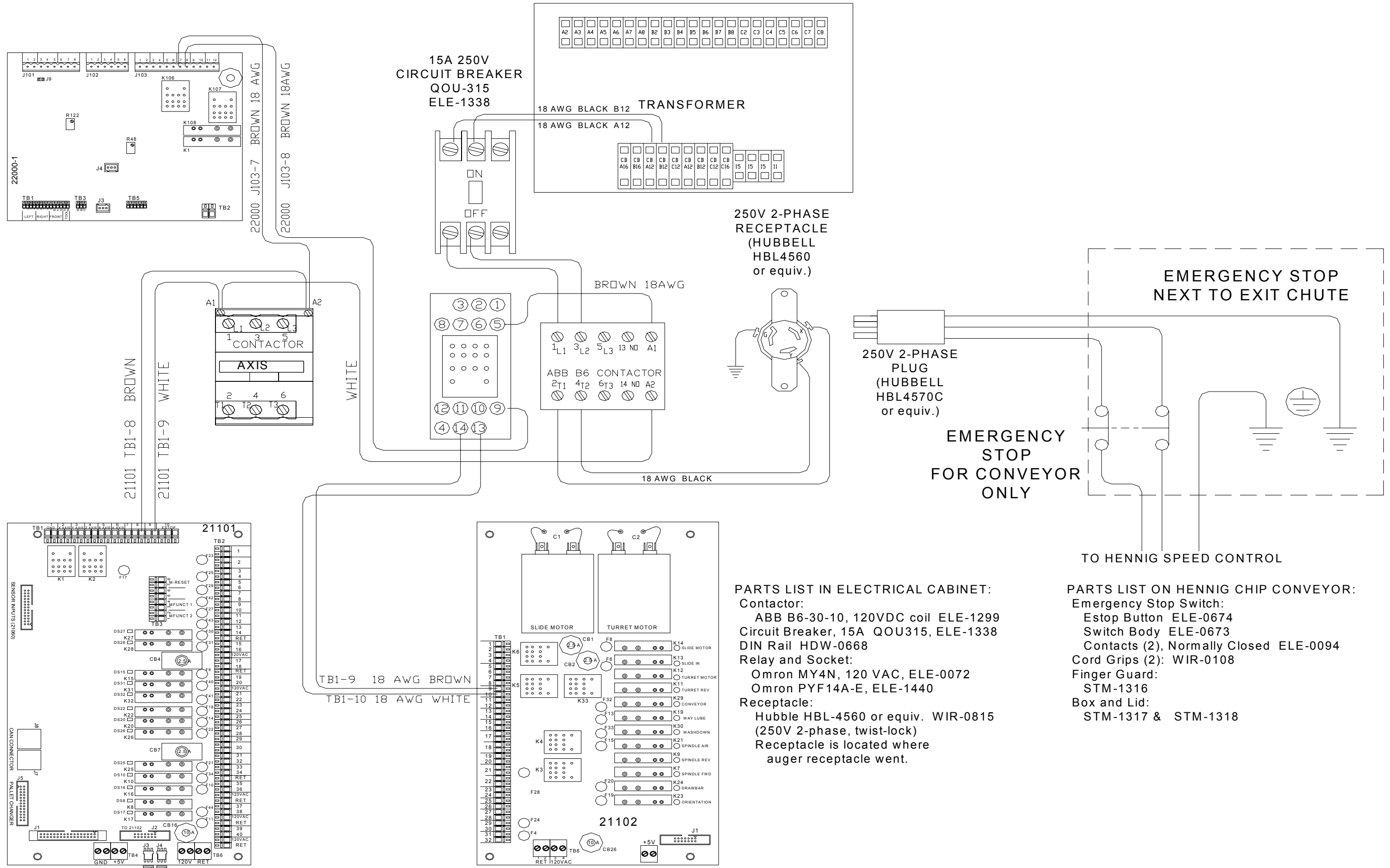

Wrg_0084_104d_pendant_21091

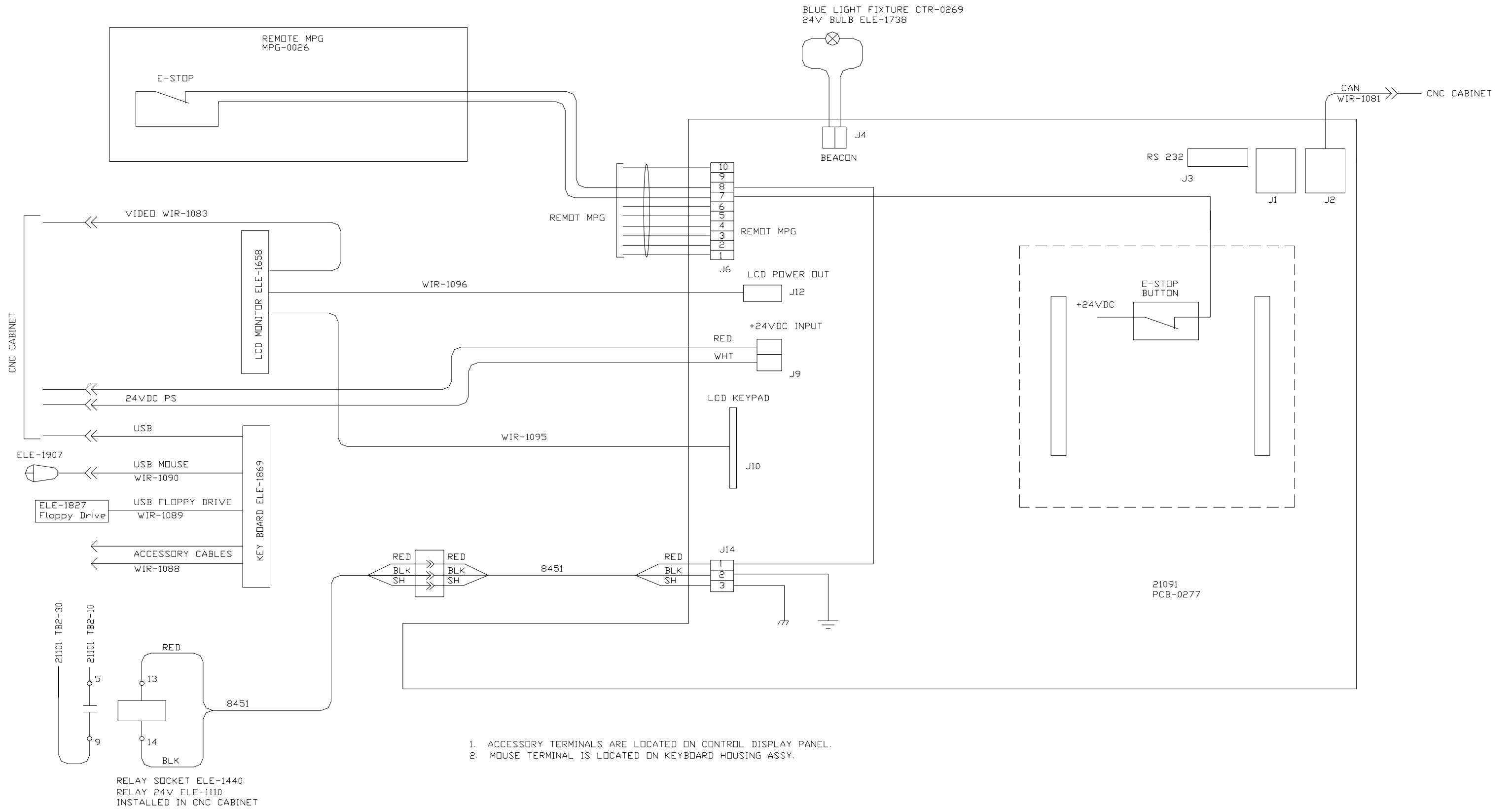

WRG_0087A_CE_Interlock_Wiring_Diagram_104D

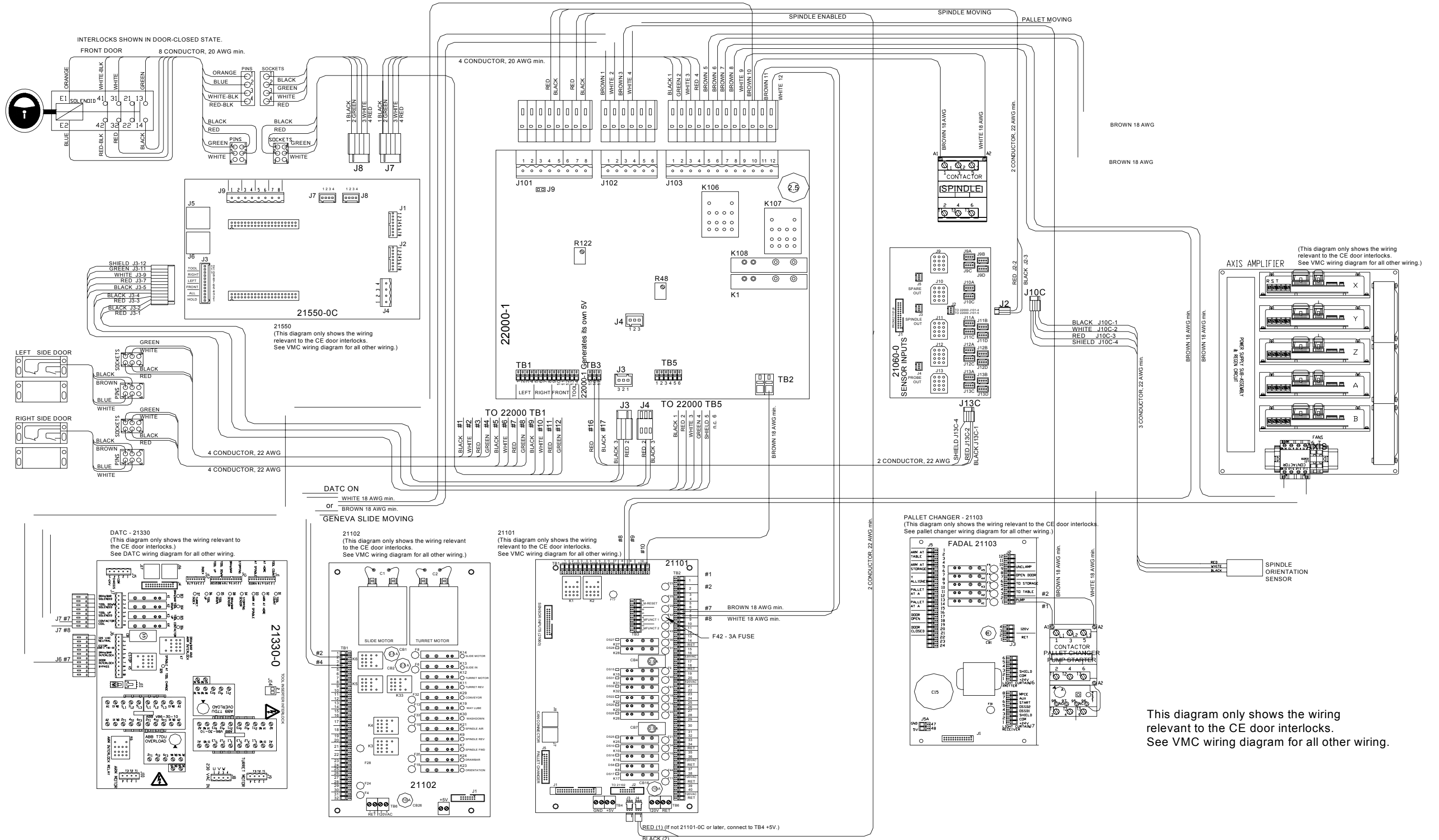

This diagram only shows the wiring relevant to the CE door interlocks. See VMC wiring diagram for all other wiring.

SECTION 13

TRM

Wrg_0055A_trm_power_in_1of8

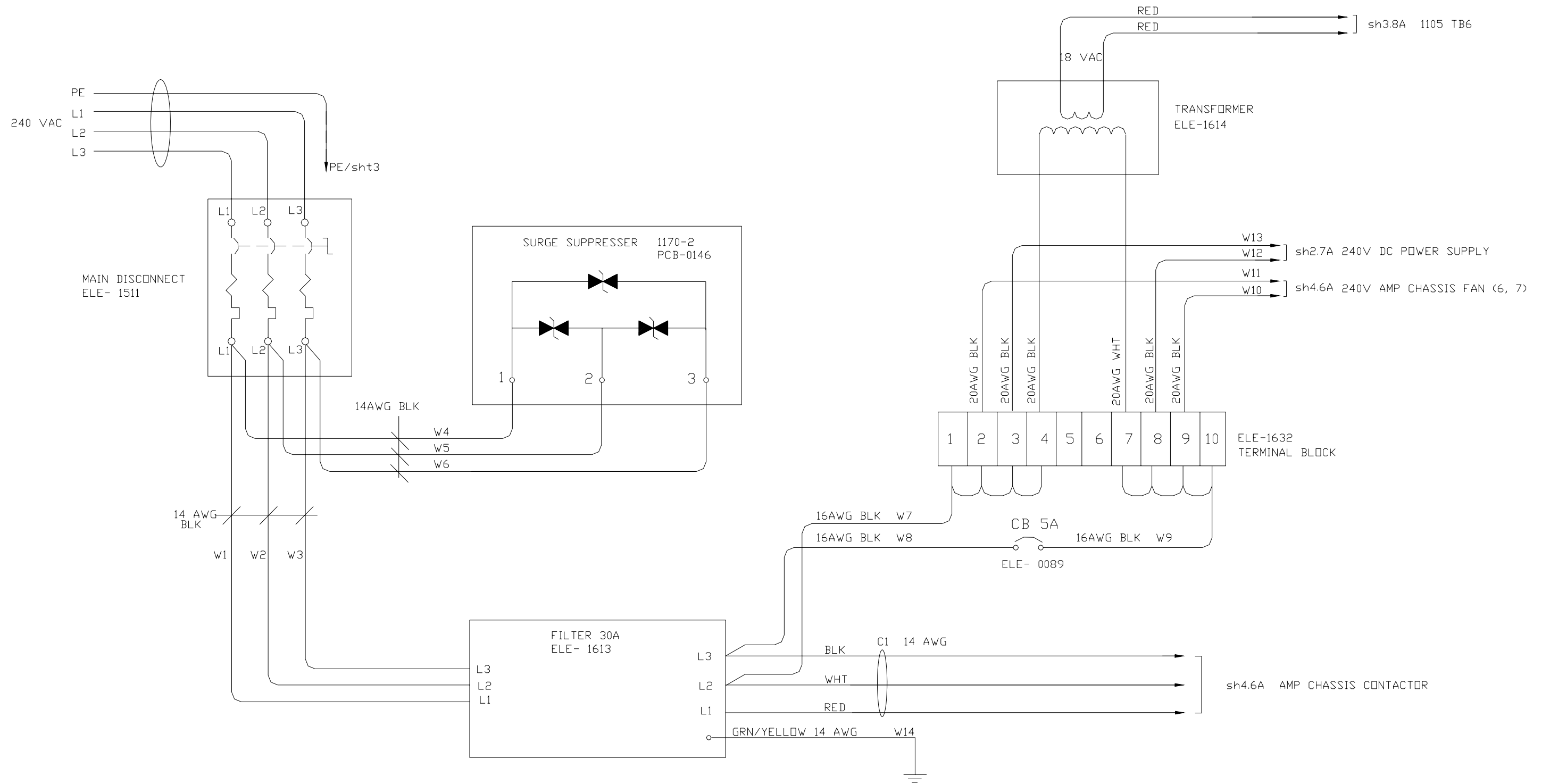

NOTE: GROUND WIRE IS CONNECTED TO GROUND BAR

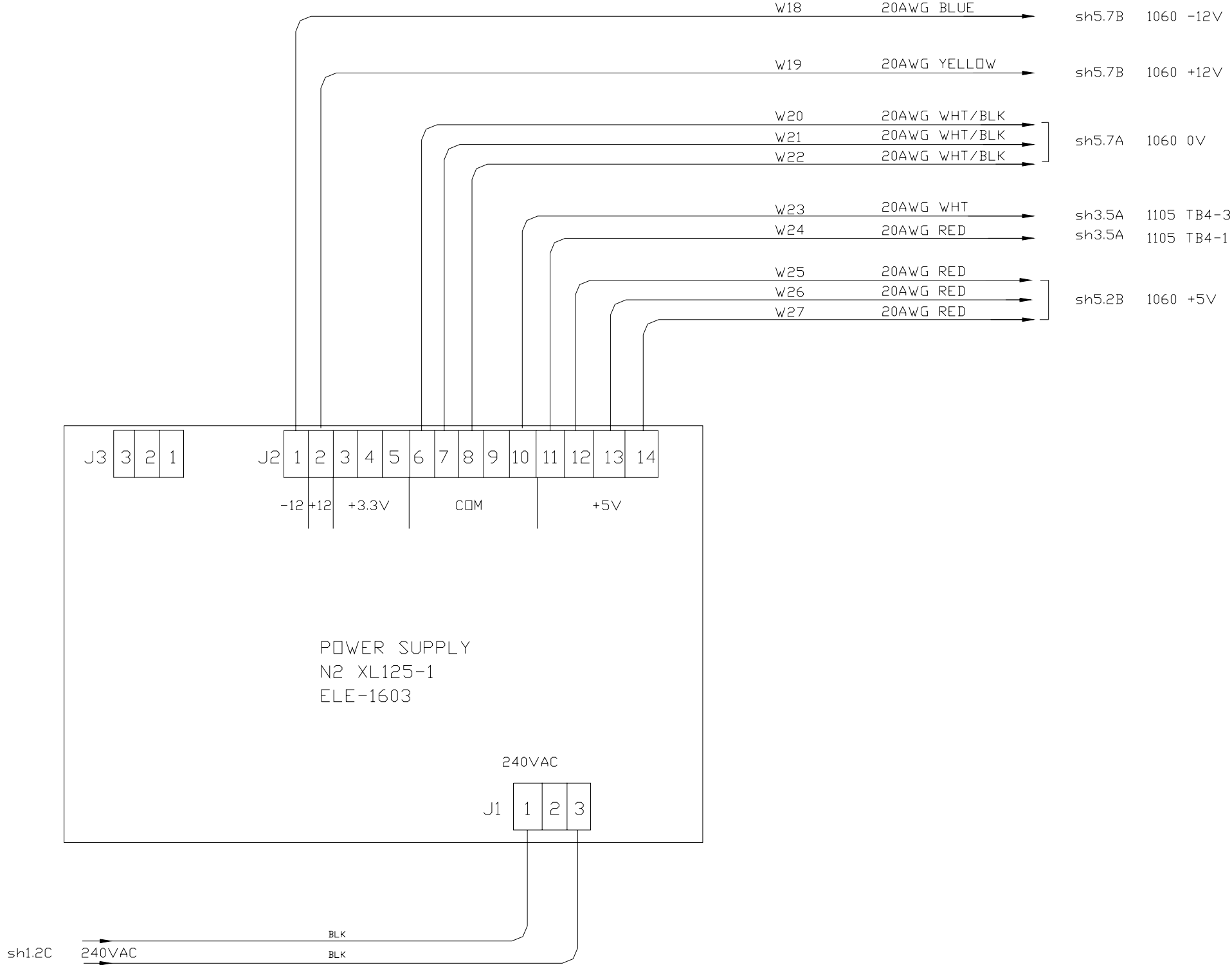

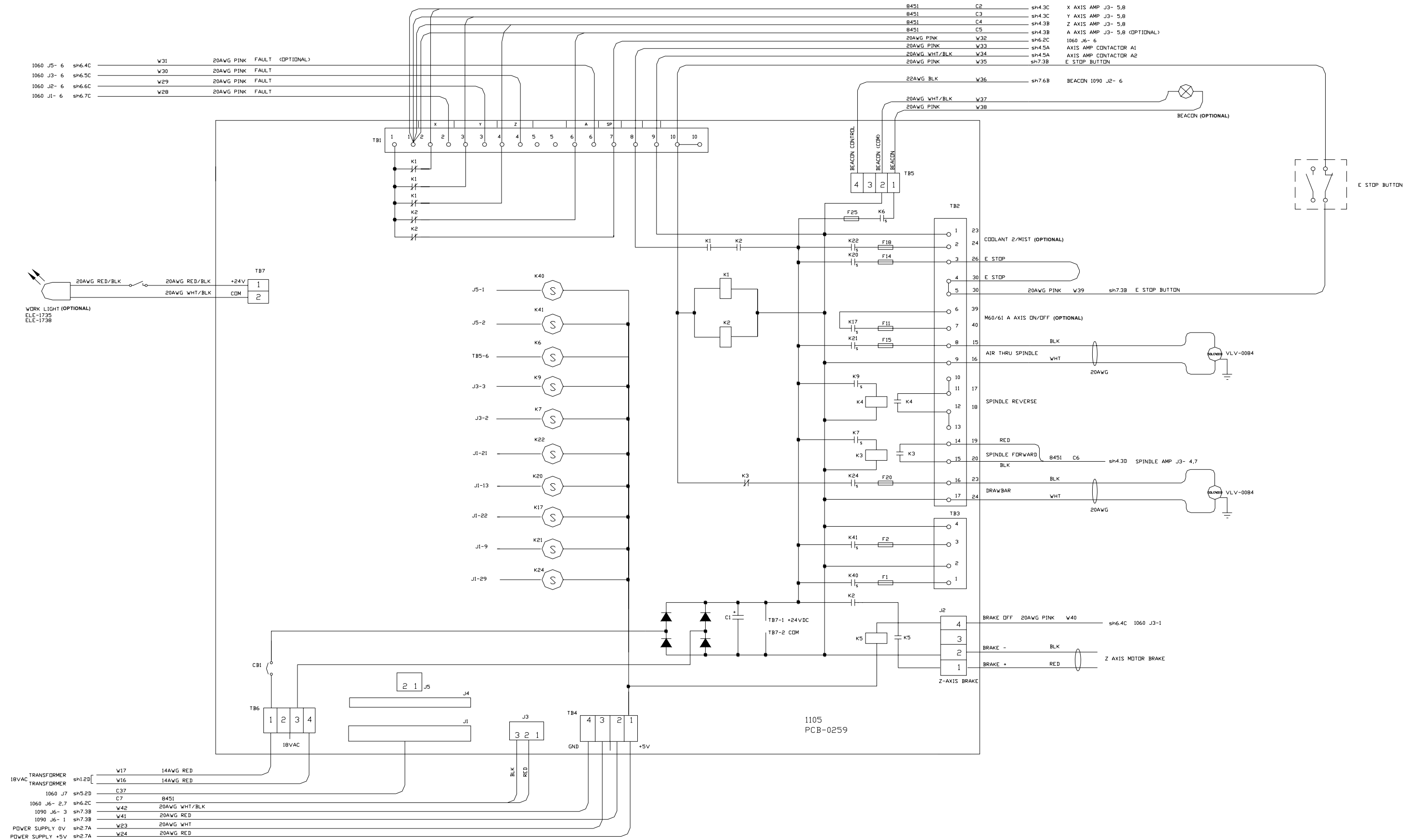

Wrg_0055A_trm_amp_4of8

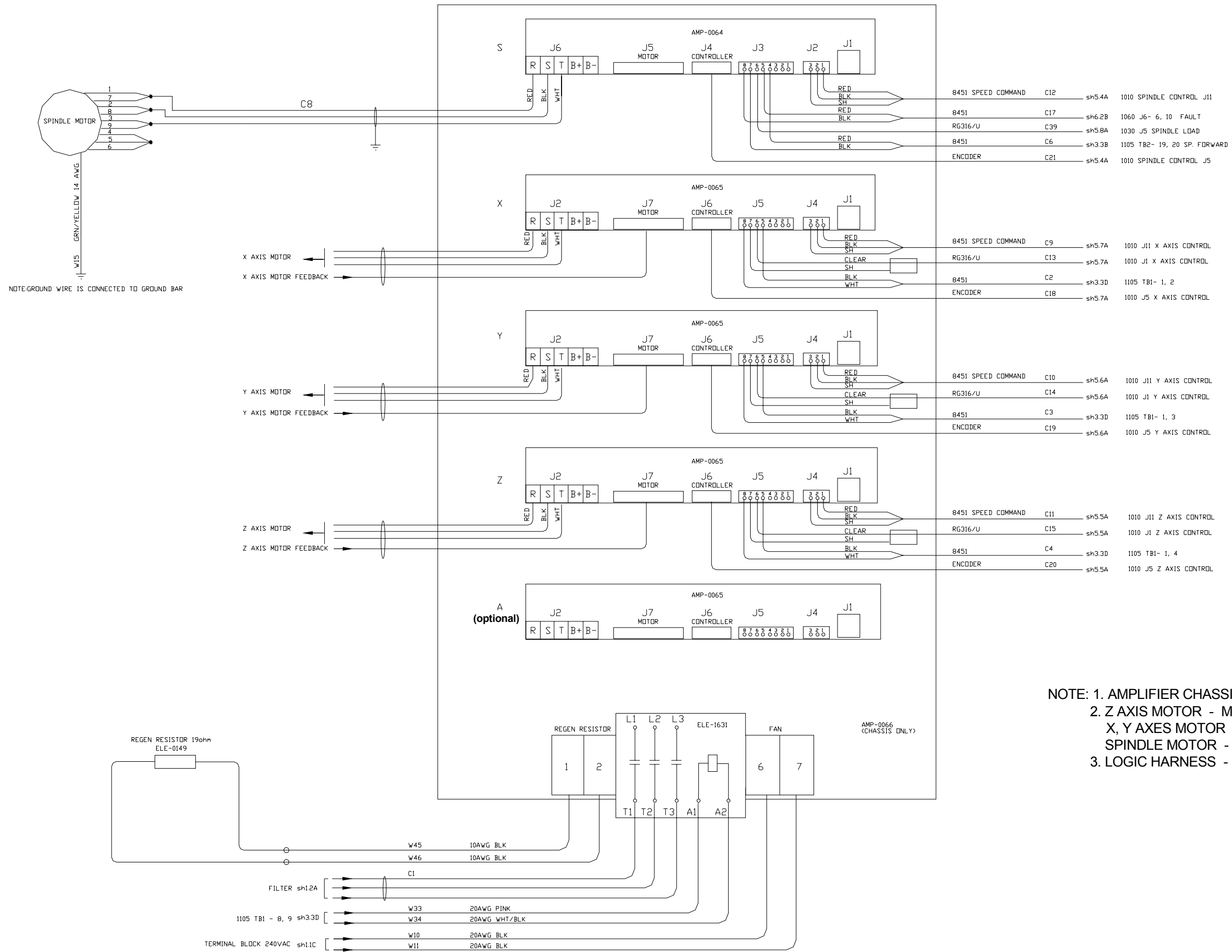

- NOTE: 1. AMPLIFIER CHASSIS WITH AMPLIFIERS - AMP-0063**
2. Z AXIS MOTOR - MTR-0233
X, Y AXES MOTOR - MTR-0234
SPINDLE MOTOR - MTR-0232
3. LOGIC HARNESS - CABLES C2, C3, C4, C6,
C9, C10, C11, C12,
C13, C14, C15, C17,
C18, C19, C20, C21
MAKE UP HARNESS WIR-0681

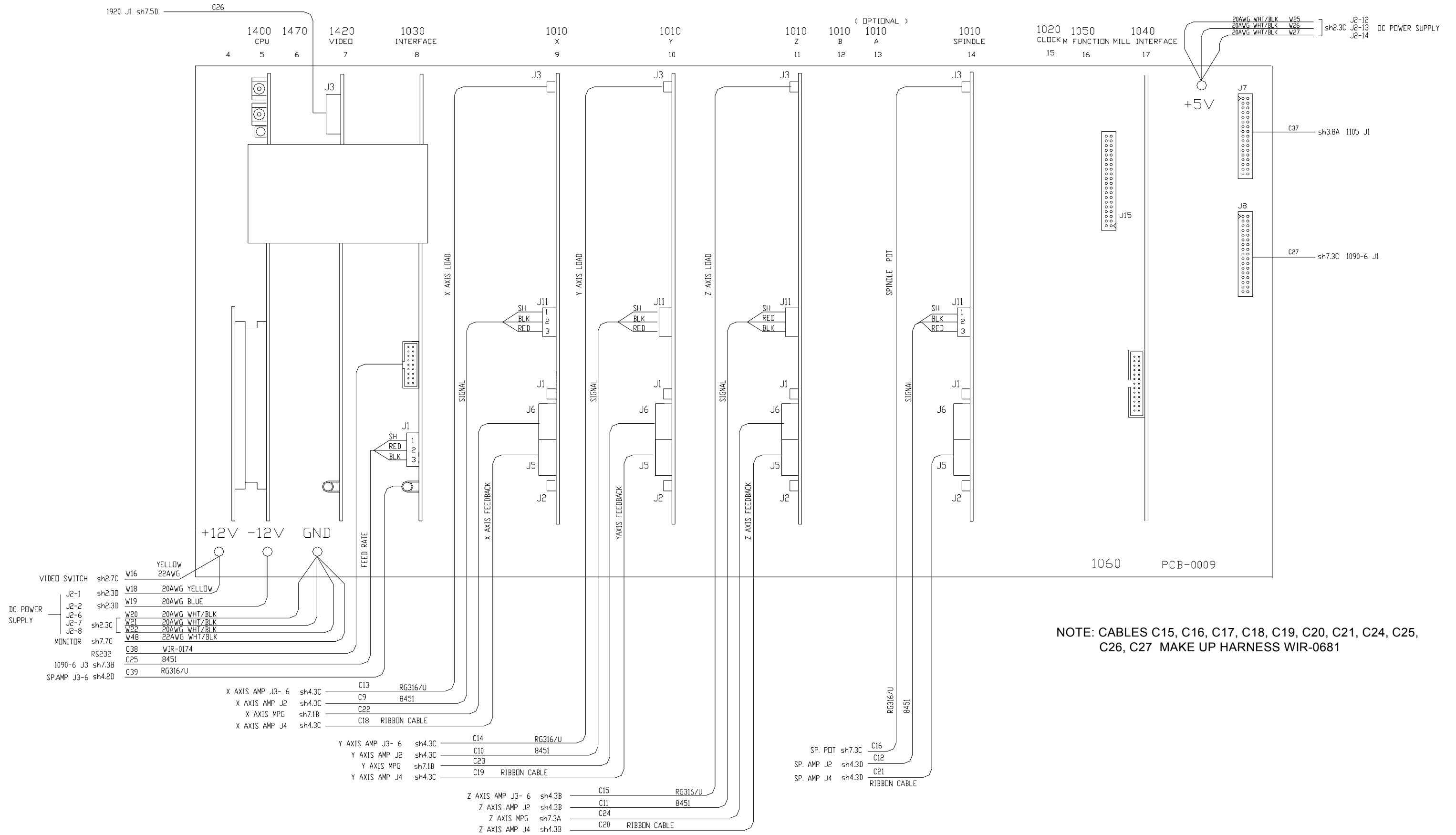

NOTE: CABLES C15, C16, C17, C18, C19, C20, C21, C24, C25, C26, C27 MAKE UP HARNESS WIR-0681

Wrg_0055A_trm_1060connectors_6of8

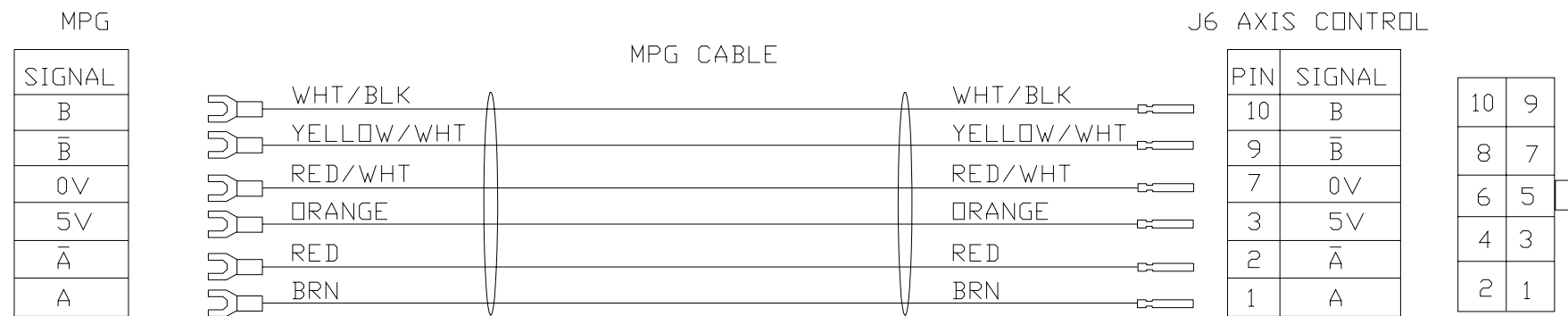
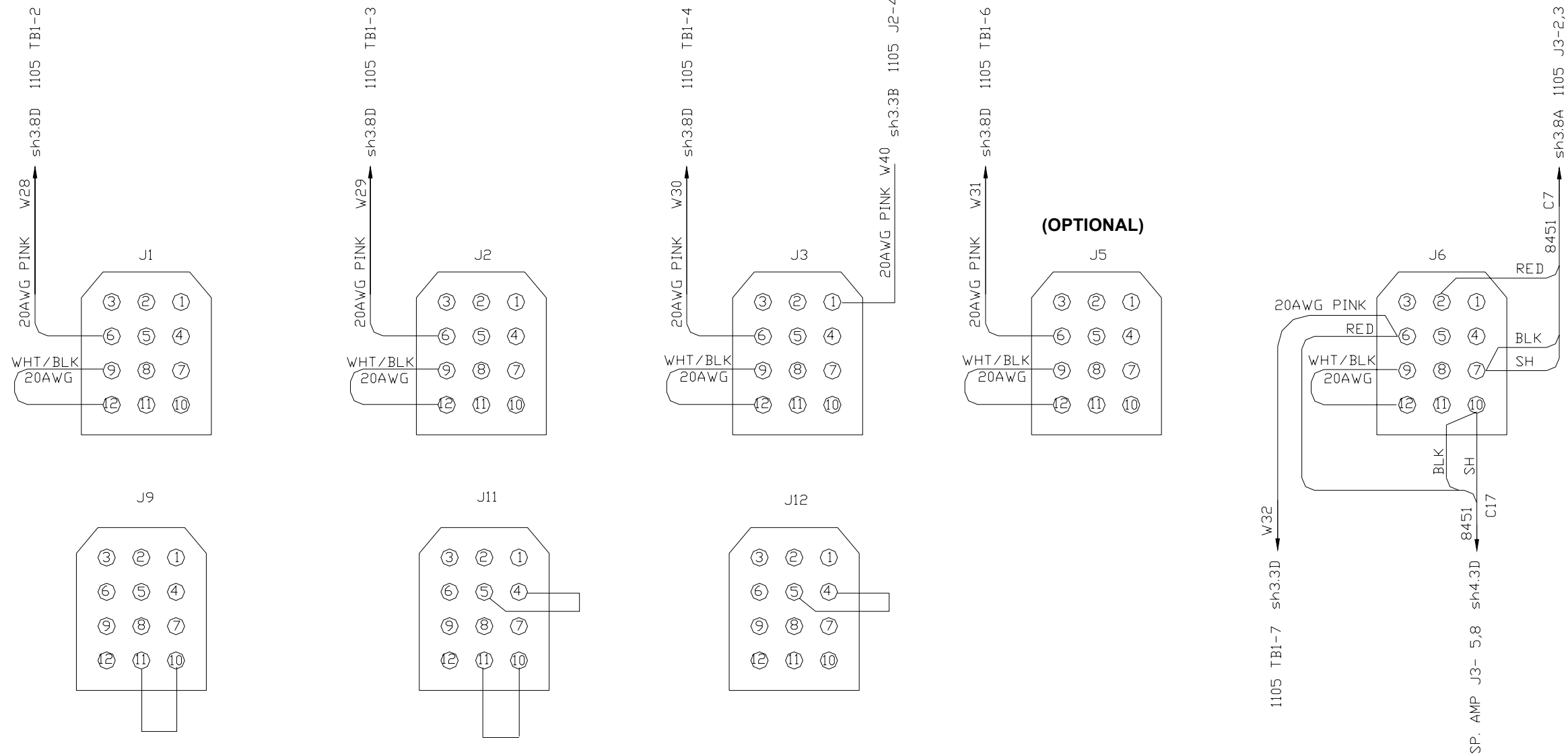

X AXIS 13ft WIR-0931
 Y AXIS 9ft WIR-0932
 Z AXIS 3ft WIR-0933

NOTE: J1, 2, 3, 4, 5, 9, 11, 12 - MOLEX CONNECTOR WIR-0045

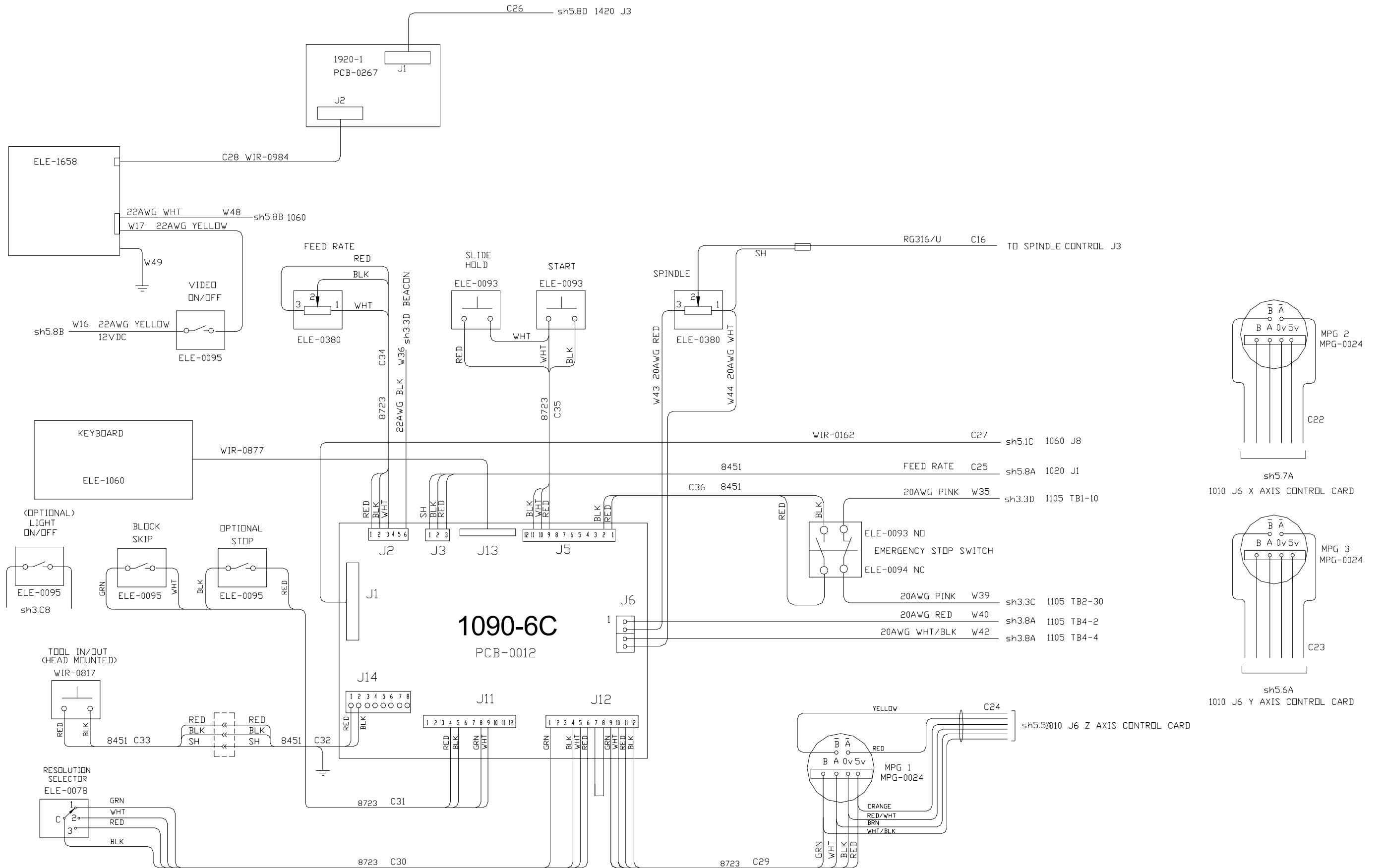

WIRES

NAME	TYPE	FADAL #	FROM - TO	SHEET
W1	14awg BLK	WIR-0916	MAIN DISCONNECT - FILTER	1
W2	14awg BLK	WIR-0917	MAIN DISCONNECT - FILTER	1
W3	14awg BLK	WIR-0918	MAIN DISCONNECT - FILTER	1
W4	14awg BLK	WIR-0919	MAIN DISCONNECT - 1170-2	1
W5	14awg BLK	WIR-0920	MAIN DISCONNECT - 1170-2	1
W6	14awg BLK	WIR-0921	MAIN DISCONNECT - 1170-2	1
W7	16awg BLK	WIR-0910	FILTER - TERMINAL BLOCK	1
W8	16awg BLK	WIR-0911	FILTER - CB	1
W9	16awg BLK	WIR-0912	CB - TEMINAL BLOCK	1
W10	20awg BLK	WIR-0913	TERMINAL BLOCK - AMP FAN	1, 4
W11	20awg BLK	WIR-0914	TERMINAL BLOCK - AMP FAN	1, 4
W12	20awg BLK	WIR-0915	TERMINAL BLOCK - DC POWER SUPPLY	1, 2
W13	20awg BLK	WIR-0915	TERMINAL BLOCK - DC POWER SUPPLY	1, 2
W14	20awg YELLOW		1060 +12V - SWITCH VIDIO ON/OFF , 7	
W15	20awg BLK/WHT		TRANSFORMER - VIDIO ON/OFF SWITCH	1, 7
W16	12awg RED		TRANSFORMER - 1105 TB-6	1, 3
W17	12awg RED		TRANSFORMER - 1105 TB-6	1, 3
W18	20awg BLUE	WIR-0922	DC POWER SUPPLY - 1060	2, 5
W19	20awg YELLOW	WIR-0922	DC POWER SUPPLY - 1060	2, 5
W20	20awg WHT/BLK	WIR-0922	DC POWER SUPPLY - 1060	2, 5
W21	20awg WHT/BLK	WIR-0922	DC POWER SUPPLY - 1060	2, 5
W22	20awg WHT/BLK	WIR-0922	DC POWER SUPPLY - 1060	2, 5
W23	20awg WHT/BLK	WIR-0922	DC POWER SUPPLY - 1105 TB-4	2, 3
W24	20awg RED	WIR-0922	DC POWER SUPPLY - 1105 TB-4	2, 3
W25	20awg RED	WIR-0922	DC POWER SUPPLY - 1060	2, 5
W26	20awg RED	WIR-0922	DC POWER SUPPLY - 1060	2, 5
W27	20awg RED	WIR-0922	DC POWER SUPPLY - 1060	2, 5
W28	20awg PINK	WIR-0923	1105 TB1-2 - 1060 J1-6	3, 6
W29	20awg PINK	WIR-0924	1105 TB1-3 - 1060 J2-6	3, 6
W30	20awg PINK	WIR-0925	1105 TB1-6 - 1060 J5-6	3, 6
W32	20awg PINK	WIR-0975	1105 TB1-7 - 1060 J6-6	3, 6
W33	20awg PINK	WIR-0944	1105 TB1-8 - AXIS AMP CONTACTOR A1	3, 4
W34	20awg WHT/BLK	WIR-0945	1105 TB1-9 - AXIS AMP CONTACTOR A2	3, 4
W35	20awg PINK	WIR-0973	1105 TB1-10 - E STOP BUTTTON	3, 7
W36	22awg BLK		1105 TB5-6 - 1090 J2-6	3, 7
W37	20awgWHT/BLK		1105 TB5-4 - BEACON	3
W38	20awg RED		1105 TB5-3 - BEACON	3
W39	20awg PINK	WIR-0974	1105 TB2-5 - E STOP BUTTON	3, 7
W40	20awg PINK	WIR-0948	1105 J2-4 - 1060 J3-1	3, 6
W41	20awg RED		1105 TB4-2 - 1090 J6-1	3, 7
W42	20awg WHT/BLK	WIR-0949	1105 TB4-4 - 1090 J6-3	3, 7
W43	20awg RED	WIR-0905	1090 J6-2 - SPINDLE PDT	3, 7
W44	20awg WHT	WIR-0906	1090 J6-4 - SPINDLE PDT	3, 7
W45	10awg BLK		AMP CHASSIS - REGEN RESISTOR	4
W46	10awg BLK		AMP CHASSIS - REGEN RESISTOR	4
W47	20awg BLK		TERMINAL BLOCK JUMPER	4
W48	22awg WHT		1060 - MONITOR	4, 7
W49	14awg GRN		MONITOR - GROUND BAR	7

CABLES

NAME	TYPE	FADAL #	FROM - TO	SHEET
C1	3cond. 14awg	WIR-0909	FILTER - AMP. CHASSIS	1, 4
C2	8451	WIR-0893	1105 TB1-1,2 - X AXIS AMP J3-5,8	3, 4
C3	8451	WIR-0894	1105 TB1-1,3 - Y AXIS AMP J3-5,8	3, 4
C4	8451	WIR-0895	1105 TB1-1,4 - Z AXIS AMP J3-5,8	3, 4
C5	8451		1105 TB1-1,6 - A AXIS AMP J3-5,8	3, 4
C6	8451	WIR-0896	1105 TB2-19,20 - SP. AMP J3-5,8	3, 4
C7	8451	WIR-0927	1105 J3-2,3 - 1060 J6-2,7	3, 6
C8	3cond. 14awg	WIR-0908	SP. AMP J6 - SP. MOTOR	6
C9	8451	WIR-0978	X AXIS AMP J2 - X AXIS CONTROL J11	4, 5
C10	8451	WIR-0880	Y AXIS AMP J2 - Y AXIS CONTROL J11	4, 5
C11	8451	WIR-0981	Z AXIS AMP J2 - Z AXIS CONTROL J11	4, 5
C12	8451	WIR-0979	SP. AMP J2 - SP. CONTROL J11	4, 5
C13	RG316/U	WIR-0893	X AXIS AMP J3-6,7 - X AXIS CONTROL J3	4, 5
C14	RG316/U	WIR-0894	Y AXIS AMP J3-6,7 - Y AXIS CONTROL J3	4, 5
C15	RG316/U	WIR-0895	Z AXIS AMP J3-6,7 - Z AXIS CONTROL J3	4, 5
C16	RG316/U		SP. PDT - SP. CONTROL J3	4, 5
C17	8451	WIR-0896	SP. AMP J3-5,8 - 1060 J6-6,10	4, 5
C18	RIBBON CABLE	WIR-0890	X AXIS AMP J4 - Y AXIS CONTROL J5	4, 5
C19	RIBBON CABLE	WIR-0891	Y AXIS AMP J4 - Y AXIS CONTROL J5	4, 5
C20	RIBBON CABLE	WIR-0892	Z AXIS AMP J4 - Z AXIS CONTROL J5	4, 5
C21	RIBBON CABLE	WIR-0889	SP. AMP J4 - SP. CONTROL J5	4, 5
C22		WIR-0931	X AXIS CONT J6 - X AXIS MPG	5, 7
C23		WIR-0932	Y AXIS CONT J6 - Y AXIS MPG	5, 7
C24		WIR-0933	Z AXIS CONT J6 - Z AXIS MPG	5, 7
C25	8451	WIR-0901	1030 J1 - 1090 J3	5, 7
C26		WIR-1010	1420 J3 - 1920-0 J1	5, 7
C27		WIR-0989	1060 J8 - 1090 J1	5, 7
C28		WIR-0984	1920-0 J2 - MONITOR	7
C29	8723	WIR-0899	1090 J12 - Z AXIS MPG	7
C30	8723	WIR-0899	1090 J12 - RESOLUTION SELECTOR	7
C31	8723	WIR-0900	1090 J11 - OPT. STOP/BLOCK SKIP	7
C32	8451	WIR-0941	1090 J14 - TOOL IN/OUT CONNECTOR	7
C33	8451	WIR-0969	TOOL IN/OUT CONNECTOR - BUTTON	7
C34	8723	WIR-0897	FEED RATE PDT - 1090 J2	7
C35	8723	WIR-0898	1090 J5 - START/SLIDE HOLD BUTTON	7
C36	8451	WIR-0898	1090 J5 - E STOP BUTTON	7
C37		WIR-0988	1105 J1 - 1060 J7	5, 7
C38			RS232 PORT - 1030 J3	5
C39	RG316/U	WIR-0896	SP. AMP J3-6 - 1030 J5	4, 5

WRG_0071A_trm_a_axis

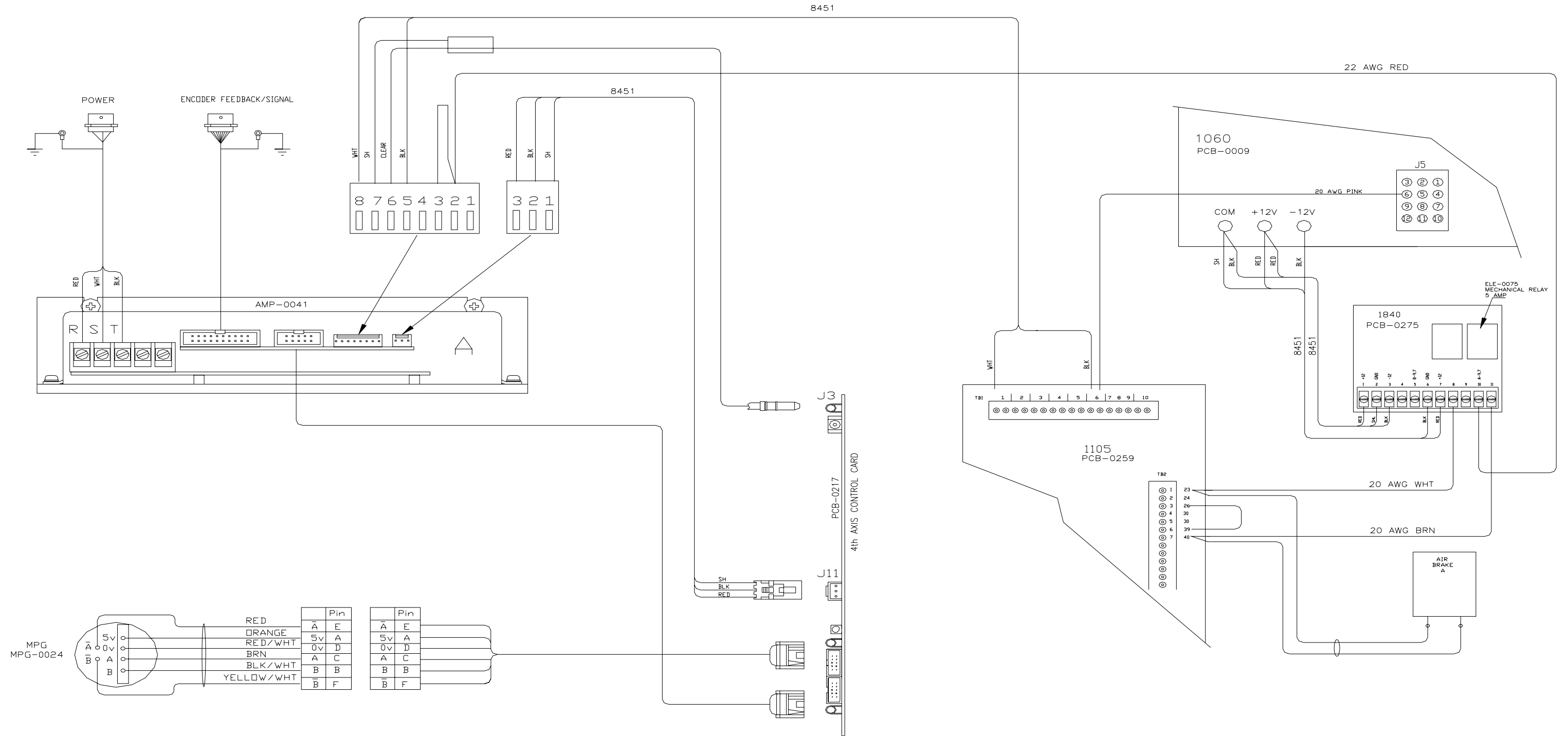

WIR-0985 - TRM SERVO DISCONNECT A AXIS