

240

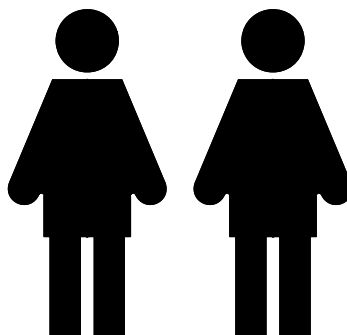
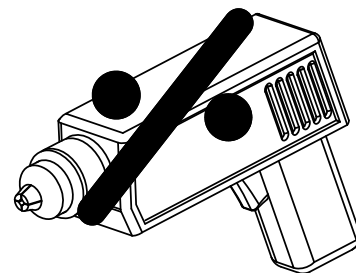
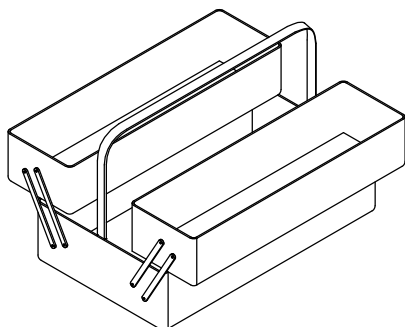
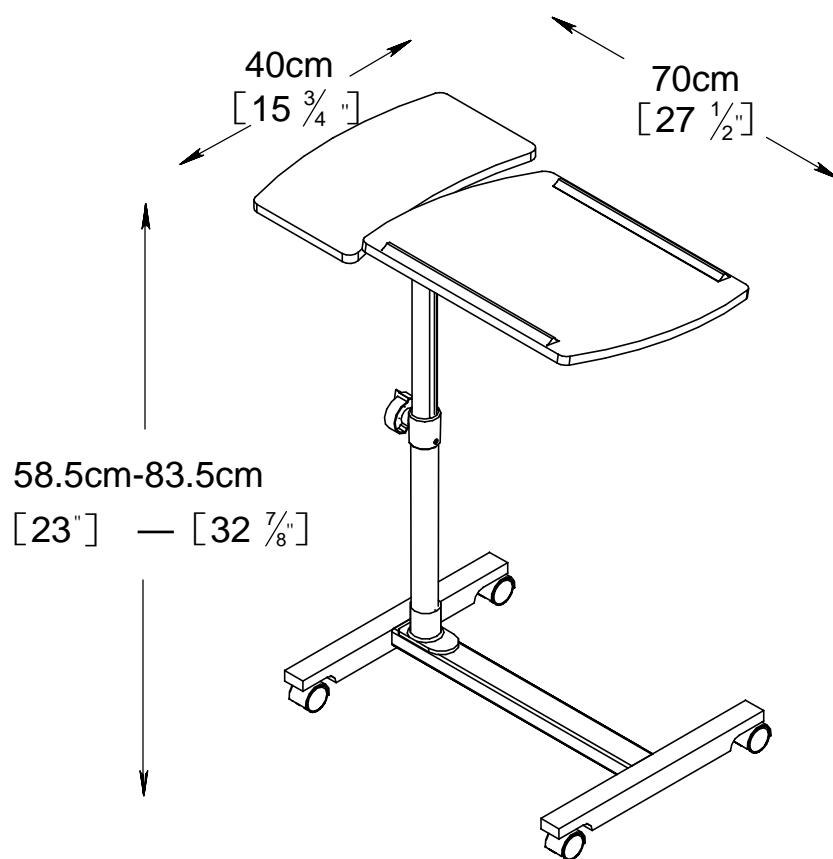

WICHTIG - FÜR SPÄTERE VERWENDUNG  
AUFBEWAHREN - SORGFÄLTIG LESEN

AVIS - Ces instructions doivent être sauvegardées  
Pour utilisation future - Les instructions doivent  
être suivies

IMPORTANTE, conservar estas instrucciones  
para futuro uso. Siga estas instrucciones atentamente

VIGTIGT - Samvejledningen skal opbevares  
i arkiv til senere brug - Skal gennemlæses nøje

NOTICE - These instructions must be saved  
for future use - Instructions must be followed

TEILCHECKLISTE  
 DISTINTA DELLE PARTI  
 TJEKLISTE  
 CHECK LIST  
 LISTE DE CONTROLE

Réf./No.	Réf./Art.	Qty./Stck./Quantité	Size / Maß / Dimension (mm)	Qty./Stck./Quantité	✓
1	56xx000024001	1	586x480x38		
2	56xx000024002	1			
3	56xx000024003	1			
4	56xx000024004	2			
5	56xx000024005	1	234x400x15		
6	56xx000024006	1	485x400x27		

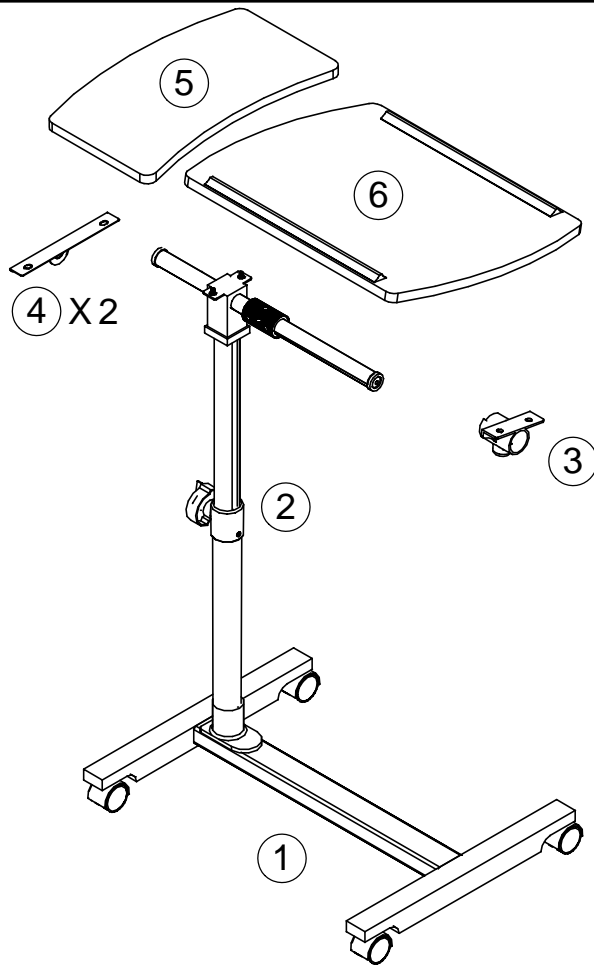

Sollten Sie eventuelle Ersatzteile  
 oder Reklamationsteile fordern,  
 dann bitten wir Sie, diese Seite  
 mitzubringen.

En cas de service apres - vente, veuillez nous  
 retourner ce coupon.

En caso de necesitar piezas de repuesto,  
 por favor adjunte esta página.

Skulle de få brug for reklamationsdele,  
 beder vi dem medsende denne side.

If you should be in the need of spareparts,  
 please enclose this page.

Name/Nom/Nombre/Navn: \_\_\_\_\_

Adresse/Dirección/Address: \_\_\_\_\_

PLZ/Code postale/CP/Post.nr: \_\_\_\_\_

Telefon/Telephone/Telefono/Phone: \_\_\_\_\_

Oberfläche/Finition/Tratamiento/  
 Behandlung/Treatment: \_\_\_\_\_









No./Référence: \_\_\_\_\_

Ursache/Motif/Motivo/Årsag/Reason: \_\_\_\_\_

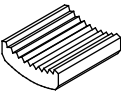
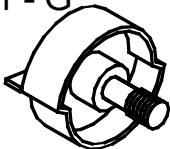

TEILCHECKLISTE - LISTE DE CONTROLE - LISTADO DE CONTROL- TJEKLISTE - CHECK LIST

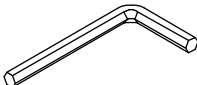
Réf./No.	Réf./Art.	Qty./Stck./Quantité	✓
A	980315	2	
B	980316	2	
C	9803203	2	
D	9803204	8	
E	9803205	2	
F	9803206	1	
G	983209	1	
H	69004	1	
I	982724	1	
J	983210	1	

<p>2 - A</p>  <p>Ø40x52mm (Ø40 x 2")</p>	<p>2 - B</p>  <p>Ø40x52mm (Ø40 x 2")</p>	<p>2 - C</p>  <p>Ø8x30mm (Ø8 x 1 1/5")</p>	<p>8 - D</p>  <p>M6x12mm (M6 x 1/2")</p>	<p>2 - E</p> 	<p>1 - F</p> 
<p>1 - G</p> 	<p>1 - H</p>  <p>4mm</p>	<p>1 - I</p>  <p>6mm</p>	<p>1 - J</p> 		

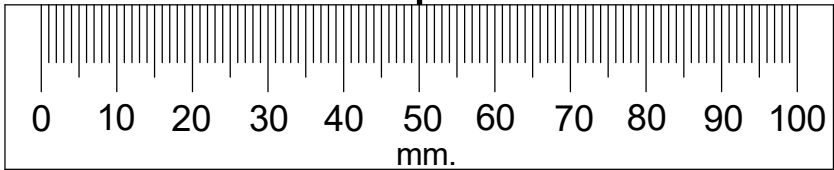
<p>Geehrter Kunde. Hier haben Sie die Möglichkeit die mitgelieferten Schrauben nachzumessen.</p> <p>Cher Client. La règle ci jointe vous permet de mesurer la visserie.</p> <p>Estimado cliente. aquí podrá medir la tornillería adjunta.</p> <p>Kære kunde. Her har De muligheden for at måle medsendte beslag.</p> <p>Dear Customer. Below you have the opportunity to measure the Enclosed Hardware.</p>	<p>Name/Nom/Nombre/Navn: _____</p> <p>Adresse/Dirección/Address: _____</p> <p>PLZ/Code postale/CP/Post.nr: _____</p> <p>Telefon/Telephone/Telefono/Phone: _____</p> <p>Oberfläche/Finition/Tratamiento/ Handling/Treatment: _____</p> <p>No./Référence: _____</p> <p>Ursache/Motif/Motivo/Årsag/Reason: _____</p>
 <p>0 10 20 30 40 50 60 70 80 90 100 mm.</p>	

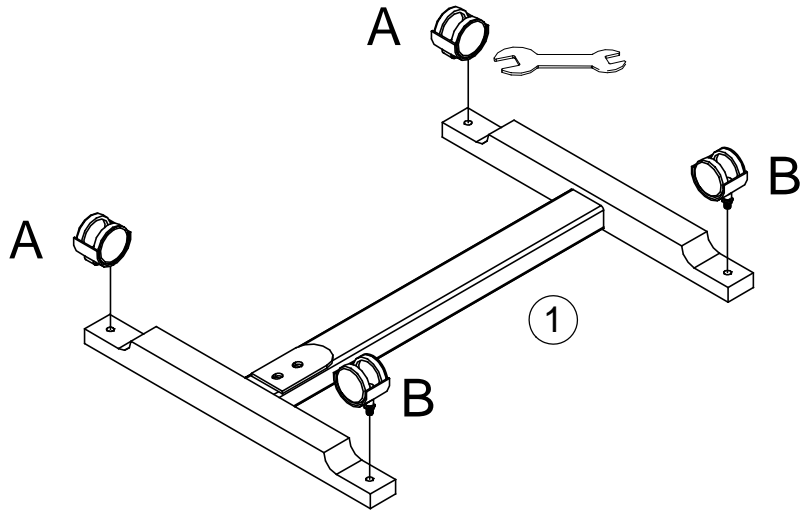

1
2 - A
2 - B
1 - J

2
2 - C
1 - I

<b>3</b>	2 - E 	1 - F 	1 - G 
----------	--	--	--

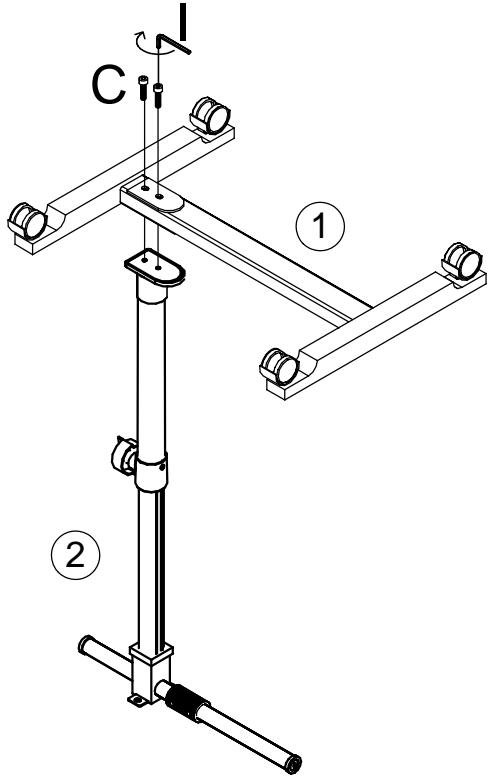

<b>4</b>	8 - D 	1 - H 
----------	--	--

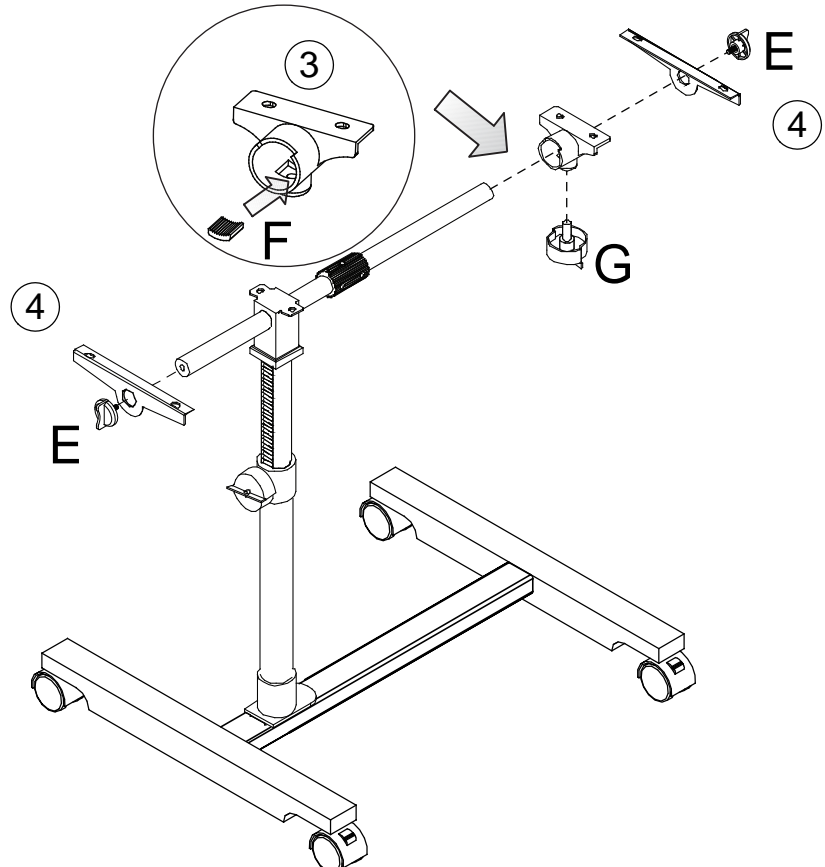

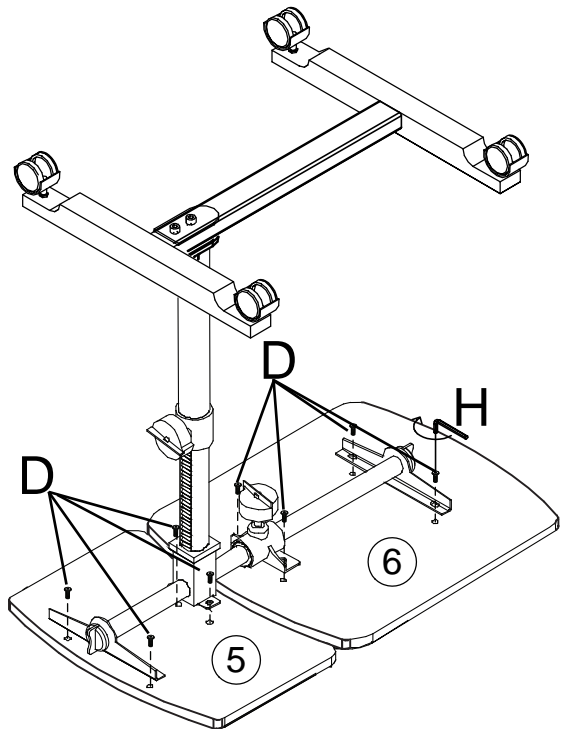
5

