

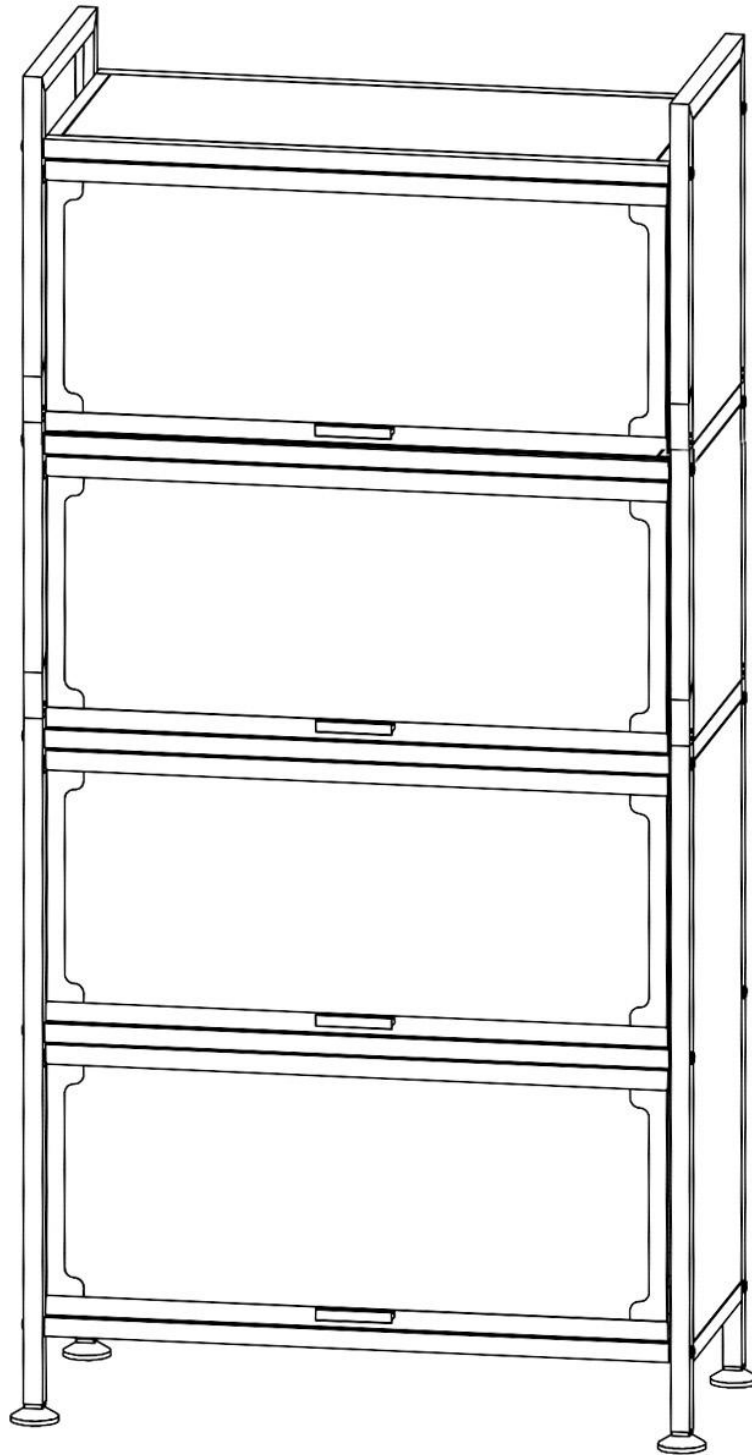



Joybos® 5-Tier Kitchen Utility Storage Cabinet with Dust-Proof Cabinet Doors

---Installation Instruction

1、 Product demonstration

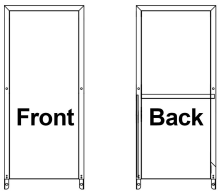
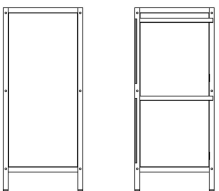
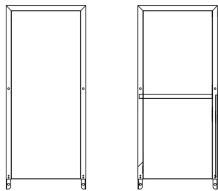
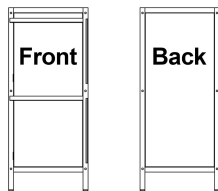
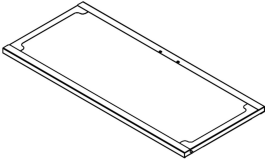
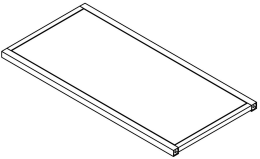
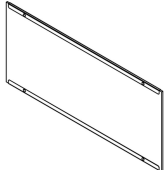
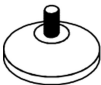
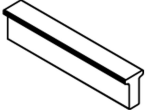

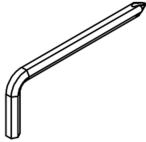
2、Parts list

| NO. | A1 | B1 | A2 | B2 |
|------|---|---|--|---|
| Pic. |  |  |  |  |
| Name | Right Upper Side Frame | Right Lower Side Frame | Left Upper Side Frame | Left Lower Side Frame |
| Qty. | 1 | 1 | 1 | 1 |
| NO. | C | D | E | F |
| Pic. |  |  |  |  |
| Name | Cabinet Door | Laminate | Backboard | Foot Pad |
| Qty. | 4 | 5 | 4 | 4 |
| NO. | G | H | I | J |
| Pic. |  |  |  |  |
| Name | Handle | Big Screw | Hexagon Wrench | Small Screw |
| Qty. | 4 | 20 | 1 | 8 |

3、 Installation steps

Step 1: Install foot pads to the left and right lower side frame;

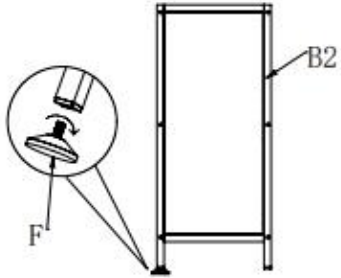

Step 2: Use large screws to connect the left and right lower side panels, (the screws do not need to be tightened);

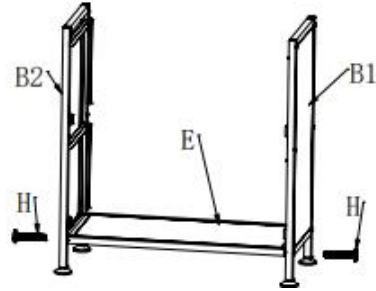

Step 3: Install one of backboards;

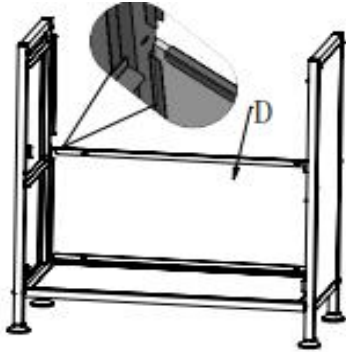

Step 4: Use large screws to connect the left and right lower side panels;

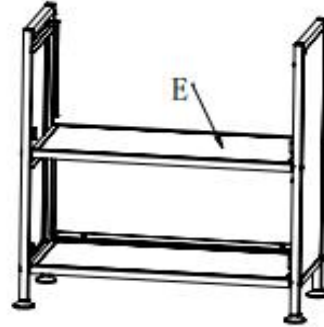

Step 5: Install one of backboards;

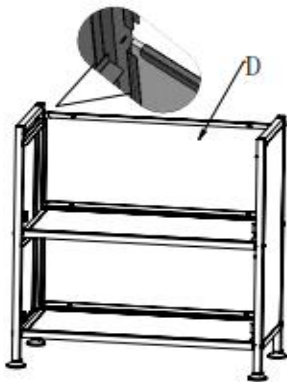

Step 6: Align the left and right upper side panels with the card slots and install them;

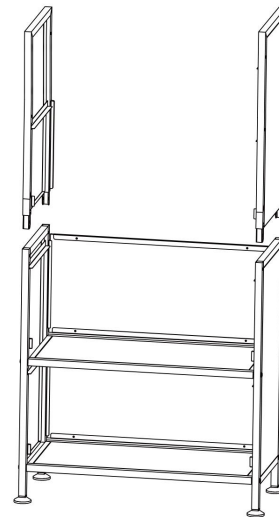

Step 7: Follow steps 2 and 3 to connect the remaining backboards and laminates with large screws;

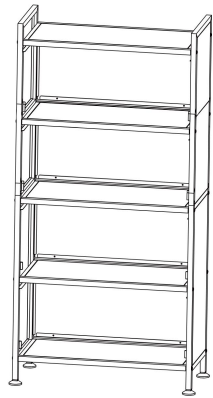

Step 8: Tighten all the screws with a Hexagon Wrench;

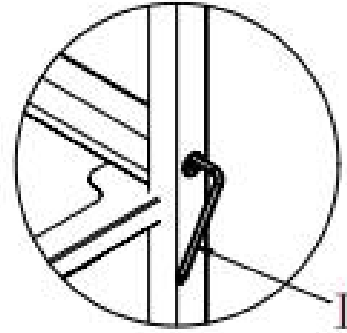

Step 9: Use small screws to install the door handle on the cabinet door;

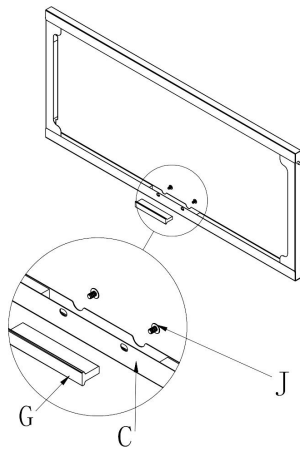

©

Step 10: Install the cabinet door by pressing the snap button on the cabinet door;

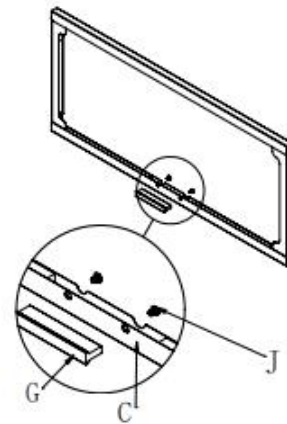

Step 11: Complete installation.

