

As with the PZX machines, the PVX manual folding machine is also one of the models designed with an ergonomic folding beam, suitable for daily work in workshops. The central release of the folding beam allows the operator an optimal position which minimizes the effort required for repetitive folding.

The sleek and robust engineering design of the PVX machine provides high rigidity for excellent folding quality as well as high accuracy, even with thicker sheets. Its numerous adjustment options and additional equipment provide even more productivity and flexibility of use.

Machine sizes available: 2 m and 3 m

Exist in manual version, semi-electric and segmented clamping beam

Manual workshop folding machines: PVX2040 and PVX3080

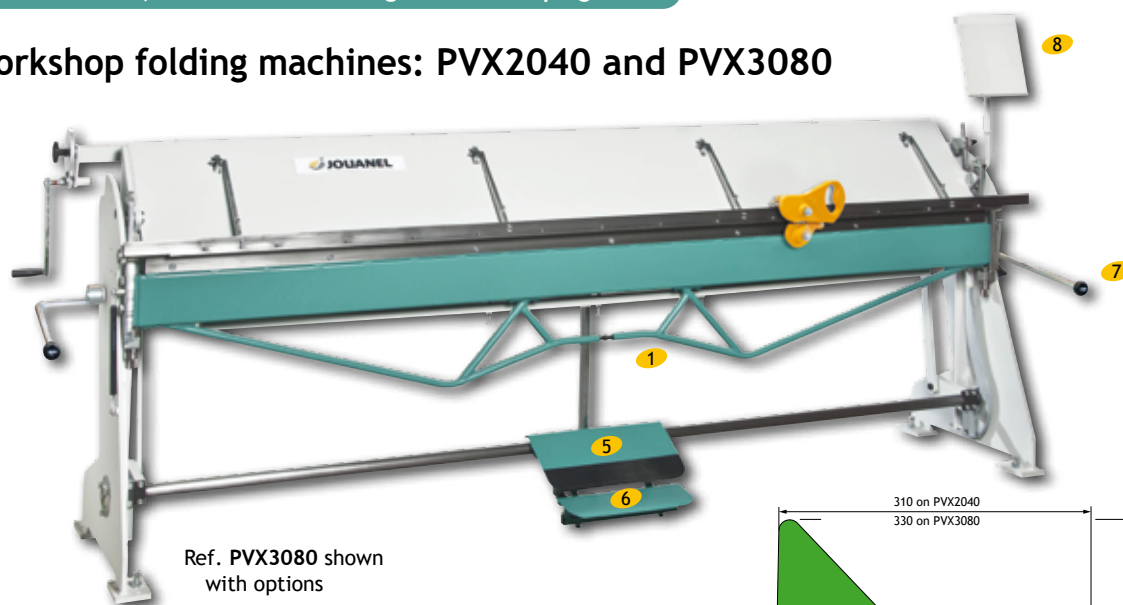

Standard equipment

- Ergonomic folding beam with narrow 15 mm interchangeable tool for making close reverse bends **1**
- Interchangeable clamping beam tool: 27° **2**
- Cylinder assists bending and ensures work reliability and rapidity, rotation of folding beam on needle roller bearings
- Angle scale **3**
- Graduated angle gauge **4**
- Operation of the upper beam by clamping **5** / opening foot pedal **6** and with a lever on both sides of the machine **7**
- Vertical adjustment of the folding beam is easy using the graduated wheel, allowing the radius setting and facilitating reverse bends
- Console and tool support **8**
- Folding beam pins mounted on roller bearings

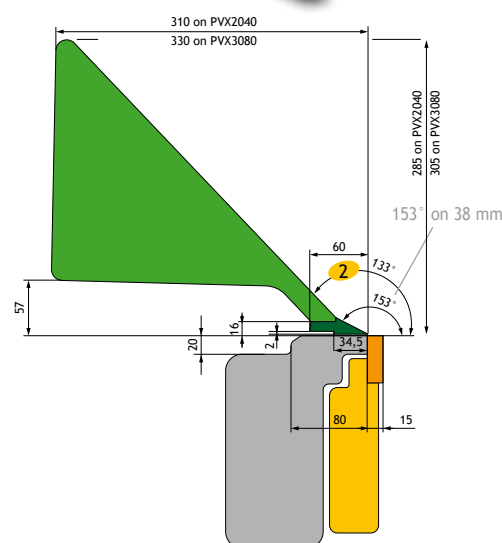

Features	PVX2040	PVX3080
Useful folding length (mm)	2040	3080
Capacity zinc / S235JR steel (mm)*	1,5/1,2	1,2/1,0
Clamping beam opening (mm)	110	110
Dimensions (mm)	2 738 x 795 x 1 215	3 775 x 795 x 1 215
Gross weight (kg)	620	850

* Capacity with standard tool of 15 mm



3 Angle scale



4 Graduated angle gauge

Options

- Additional narrow 12 mm-folding beam tool Ref. PVX-REG12-2040 / PVX-REG12-3080 (capacity - 30%)
- Additional wide 20 mm-folding beam tool Ref. PVX-REG20-2040 / PVX-REG20-3080 (capacity + 20%)
- Other options: see pages 15 to 17

Manual workshop folding machines with segmented clamping beam - PVXT



Manual workshop folding machines with segmented clamping beam: PVX2040T and PVX3080T

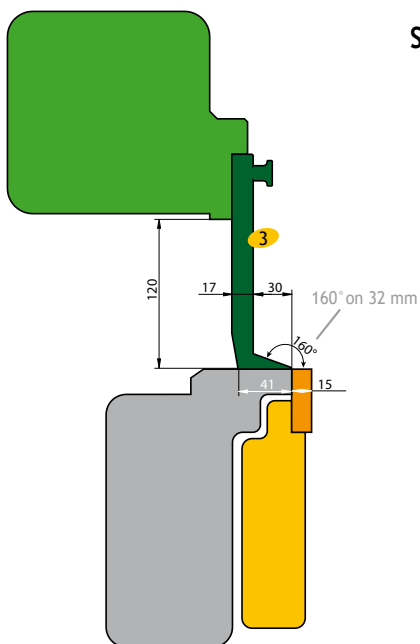

Standard equipment

- Quick disassembly of the segments with pull-device **1**
- Clamping beam with engraved segments (width of the segments)
- Left **2** and right corner segments (30 mm)
- Interchangeable clamping beam segmented tool: 20° **3**
- Automatic clamping beam lock
- Ergonomic folding beam **4** with narrow 15 mm interchangeable tool for making close reverse bends
- Cylinder assists bending and ensures work reliability and rapidity, rotation of folding beam on needle roller bearings
- Graduated angle gauge **5**
- Angle scale **6**
- Operation of the upper beam by clamping **7** / opening foot pedal **8** and with a lever on both sides of the machine **9**
- Vertical adjustment of the folding beam is easy using the graduated wheel, allowing the radius setting and facilitating reverse bends
- Console and tool support **10**
- Support for segments **11**
- Folding beam pins mounted on roller bearings

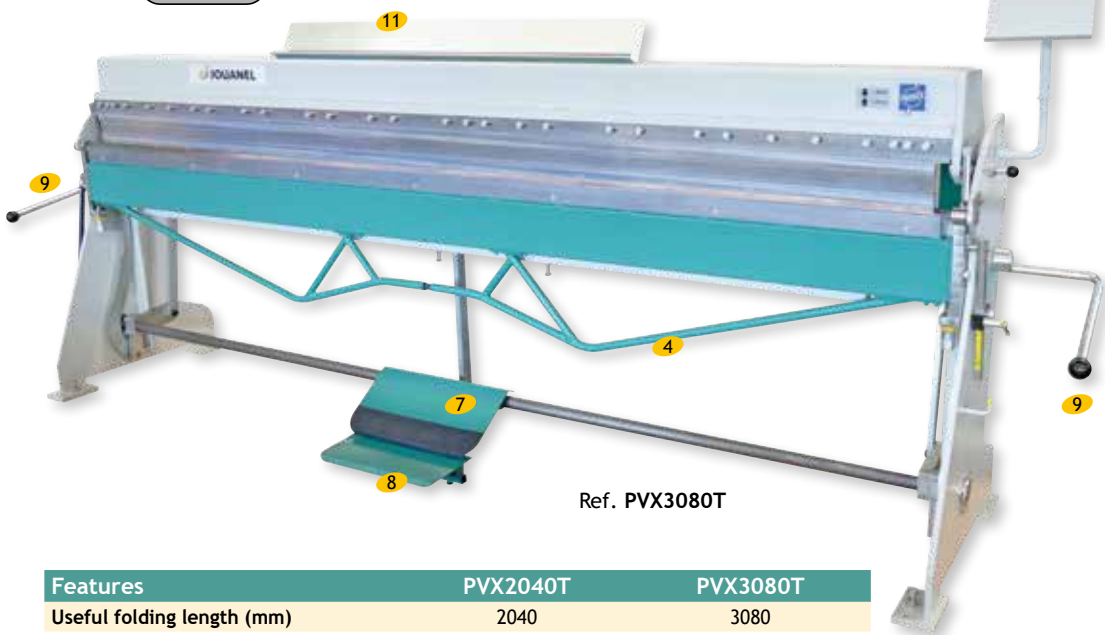
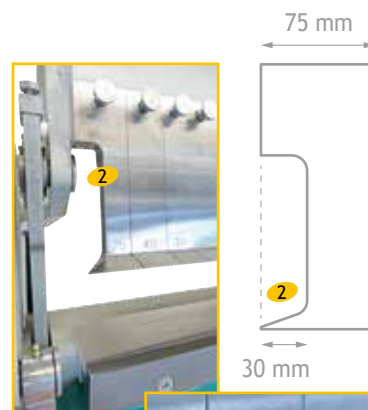

Ref. PVX3080T



1 Quick disassembly of the segments with pull-device



5 Graduated angle gauge

6 Angle scale

Features	PVX2040T	PVX3080T
Useful folding length (mm)	2040	3080
Capacity zinc / S235JR steel (mm)*	1,2 / 1	1 / 0,8
Clamping beam tool angle	160°	160°
Clamping beam opening (mm)	95	95
Useful segment height (mm)	120	120
Dimensions (mm)	2710 L x 800 l x 1400 H	3750 L x 800 l x 1400 H
Gross weight (kg)	670	915
Useful segment height (mm)	25, 30, 35, 50, 75, 75, 100, 150, 200, 200, 200, 300, 300, 300	25, 30, 35, 40, 50, 75, 75, 100, 100, 150, 150, 200, 200, 250, 250, 250, 300, 300, 300

* Capacity with standard 15 mm-tool

Options

- Additional narrow 12 mm-folding beam tool Ref. PVX-REG12-2040 / PVX-REG12-3080 (capacity - 30%)
- Additional wide 20 mm-folding beam tool Ref. PVX-REG20-2040 / PVX-REG20-3080 (capacity + 20%)
- Other options: see pages 15 to 17

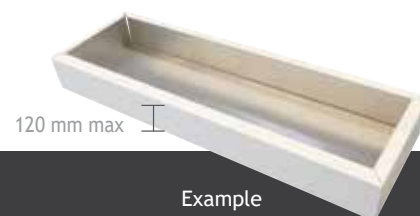

• Semi-electric workshop folding machines: PVX2040PE and PVX3080PE

PVXPE folding machines with electric clamping beams have the same folding capacities as the PVX manual machines. The electric clamping beam lock gives the operator more comfort, ergonomics and faster working speed.

- The clamping beam releases automatically upon fold completion, no need for pedal activation
- Moveable foot operated control, more convenient for clamping large-sized sheets
- Flattening folds is easy and effortless with this motorized clamping beam
- Clamping beam height can be adjusted easily
- Security device prevents crushing

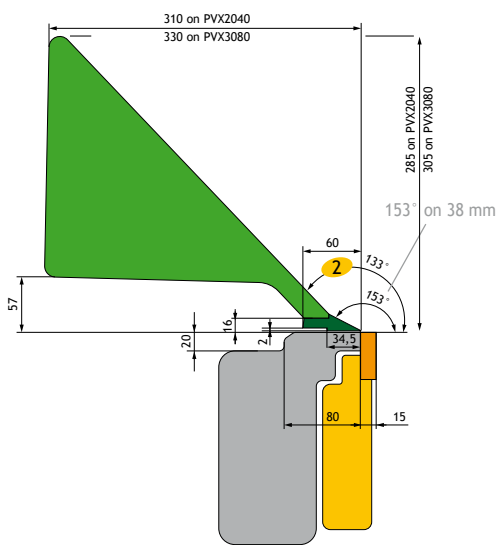

Ref. PVX3080PE

Standard equipment

- Ergonomic folding beam **1** with narrow 15 mm interchangeable tool for making close reverse bends
- Interchangeable clamping beam tool: 20° **2**
- Cylinder assists bending, ensures work reliability and rapidity, rotation of folding beam on needle roller bearings
- Graduated angle gauge **3**
- Angle scale **4**
- Clamping operated by foot pedal **5**
- Automatic clamping beam release once folding is complete
- Manual release operated by foot pedal **6**
- Vertical adjustment of the folding beam is easy using the graduated wheel, allowing the radius setting and facilitating reverse bends
- Console and tool support **7**
- Folding beam pins mounted on roller bearings



3 Graduated angle gauge



4 Angle scale

• Options

- Additional narrow 12 mm-folding beam tool
Ref. PVX-REG12-2040 and PVX-REG12-3080 (capacity - 30%)
- Additional wide 20 mm-folding beam tool
Ref. PVX-REG20-2040 and PVX-REG20-3080 (capacity + 20%)
- Other options: see pages 15 to 17

Features	PVX2040PE	PVX3080PE
Useful folding length (mm)	2040	3080
Capacity zinc / S235JR steel (mm)*	1,5/1,2	1,2/1,0
Clamping beam opening (mm)	110	110
Power supply (V)**	220 V single-phase	220 V single-phase
Power (kW)	0,25	0,25
Dimensions (mm)	2 600 x 795 x 1 215	3 600 x 795 x 1 215
Gross weight (kg)	706	936

* Capacity with standard 15 mm-tool

** Voltage choice to be specified upon order

Semi-electric folding machines with segmented clamping beam - PVXTPE

● Semi-electric folding machines with segmented clamping beam: PVX2040TPE and PVX3080TPE

PVXTPE folding machines with electric clamping beams have the same folding capacities as the PVXT manual machines. The electric clamping beam lock gives the operator more comfort, ergonomics and faster working speed.

- The clamping beam releases automatically upon fold completion, no need for pedal activation
- Moveable foot operated control, more convenient for clamping large-sized sheets
- Flattening folds is easy and effortless with this motorized clamping beam
- Clamping beam height can be adjusted easily
- Security device prevents crushing

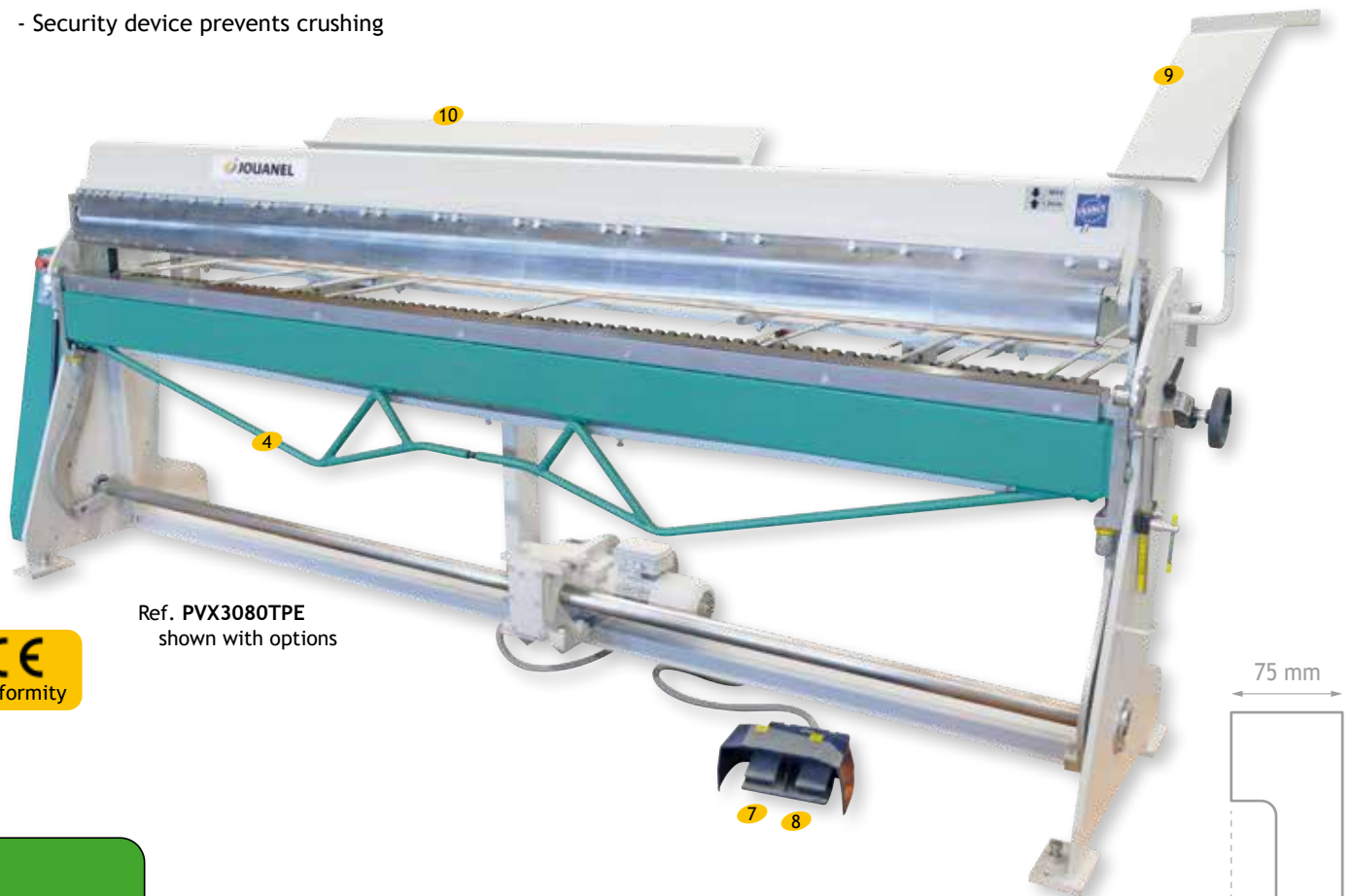

Ref. PVX3080TPE
shown with options

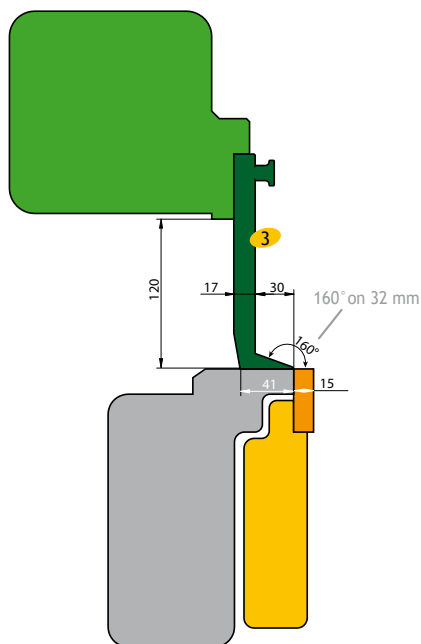
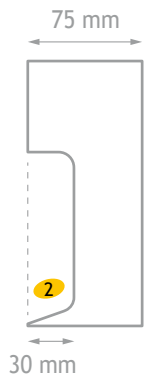

Standard equipment

- Quick disassembly of the segments with pull-device **1**
- Clamping beam with engraved segments (width of the segments)
- Left **2** and right corner segments (30 mm)
- Interchangeable clamping beam segmented tool: 20° **3**
- Automatic clamping beam lock
- Ergonomic folding beam **4** with narrow 15mm interchangeable tool for making close reverse bends
- Cylinder assists bending and ensures work reliability and rapidity, rotation of folding beam on needle roller bearings
- Graduated angle gauge **5**
- Angle scale **6**
- Clamping operated by foot pedal **7**
- Automatic clamping beam release once folding is complete
- Manual release operated by foot pedal **8**
- Vertical adjustment of the folding beam is easy using the graduated wheel, allowing the radius setting and facilitating reverse bends
- Console and tool support **9**
- Support for segments **10**
- Folding beam pins mounted on roller bearings



Semi-electric folding machines with segmented clamping beam - PVXTPE

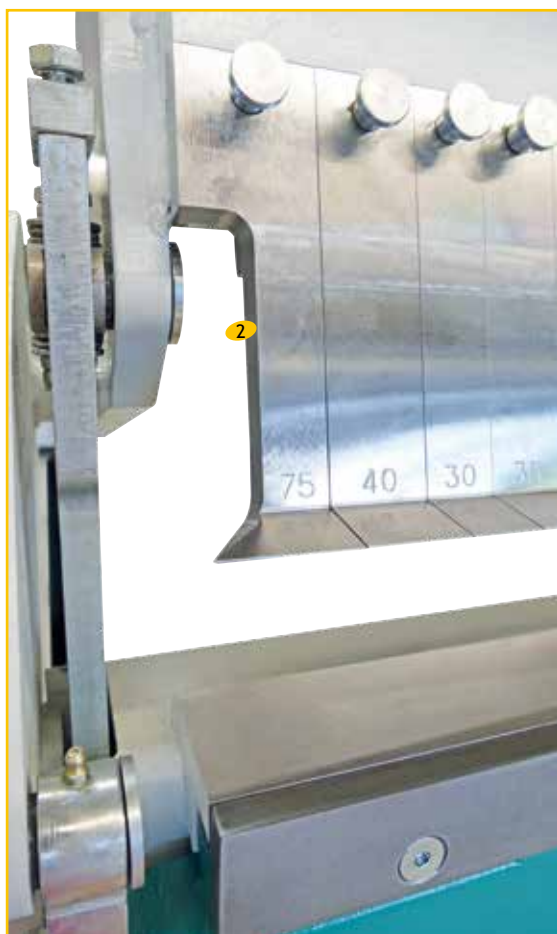

1 Quick disassembly of the segments with pull-device

5 Graduated angle gauge

6 Angle scale

Features	PVX2040TPE	PVX3080TPE
Useful folding length (mm)	2040	3080
Capacity zinc / S235JR steel (mm)*	1,2 / 1	1 / 0,8
Clamping beam tool angle	160°	160°
Clamping beam opening (mm)	95	95
Useful segment height (mm)	120	120
Dimensions (mm)	2 600 L x 800 l x 1400 H	3 600 L x 800 l x 1400 H
Gross weight (kg)	855	1130
Power supply (V)**	220 V single-phase	220 V single-phase
Power (kW)	0,25	0,25
Segments width (mm)	25, 30, 35, 50, 75, 75, 100, 150, 200, 200, 200, 300, 300, 300	25, 30, 35, 40, 50, 75, 75, 100, 100, 150, 150, 200, 200, 200, 250, 250, 250, 300, 300, 300

* Capacity with standard 15 mm-tool

** Voltage choice to be specified upon order

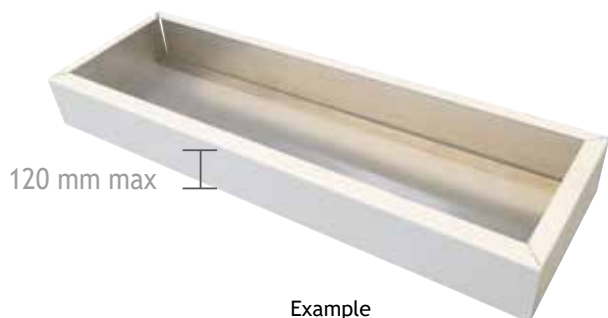

Options

- Additional narrow 12 mm-folding beam tool
Ref. PVX-REG12-2040 and PVX-REG12-3080 (capacity - 30%)
- Additional wide 20 mm-folding beam tool
Ref. PVX-REG20-2040 and PVX-REG20-3080 (capacity + 20%)
- Other options: see pages 15 to 17

Additional equipment for PCA, PCX, PZX, PVX, PBS, PVS

BACK GAUGES

● Sliding back gauge type GAS ①

- For folding machines PBS, 2 adjustable gauge arms from 25 to 500 mm, Ref. **PBS-GAS**



● Sliding back gauge type X ②

- For folding machine Ref. PCA2040, 2 adjustable gauge arms from 55 to 510 mm, Ref. **PCAB2040**
- For folding machine Ref. PCA2040, adjustable gauge arm from 55 to 510 mm, Ref. **PCABS2**
- For folding machine Ref. PCX1020, 2 adjustable gauge arms from 40 to 510 mm, Ref. **PCXB1020**
For folding machines Ref. PCX2040A and PZX2040, 2 adjustable gauge arms from 40 to 510 mm, Ref. **PCXB2040**
For folding machines Ref. PCX2540A and PZX2540, 2 adjustable gauge arms from 40 to 510 mm, **PCXB2540**
- For folding machines Ref. PCX1020, PCX2040A, PCX2540A and PZX2040, PZX2540, additional gauge arm from 40 mm to 510 mm, Ref. **PCXBS2-2.5**
- For folding machine Ref. PCX3080A, 2 adjustable gauge arms from 65 to 530 mm, Ref. **PCXB3040**
- For folding machine Ref. PCX3080A, additional gauge arm from 65 to 530 mm, Ref. **PCXBS3**
- For folding machines Ref. PVX2040, Ref. PVX2040T, Ref. PVX2040PE, Ref. PVX2040TPE, 2 adjustable gauge arms from 60 to 750 mm, Ref. **PVXB2040**
For folding machines Ref. PVX3080, Ref. PVX3080T, Ref. PVX3080PE, Ref. PVX3080TPE, 2 adjustable gauge arms from 60 to 750 mm, Ref. **PVXB3080**
- For folding machines Ref. PVX2040, Ref. PVX2040T, Ref. PVX2040PE, Ref. PVX2040TPE, Ref. PVX3080, Ref. PVX3080T, Ref. PVX3080PE, Ref. PVX3080TPE, additional gauge arm: 750 mm, Ref. **PVXBS-C750**
- For folding machines Ref. PVS2050M and PVS3080MR 2 adjustable gauge arms from 60 to 750 mm, Ref. **PVSB2040** and **PVSB3080**
- For folding machines Ref. PVS2050M and PVS3080MR additional gauge arm up to: 750 mm, Ref. **PVSB-C750**

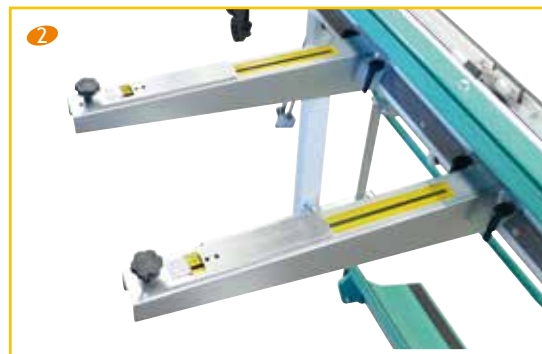

● Rack-operated back gauge type GAC, equipped with a digital counter ③

- For folding machines Ref. PBS2040 and Ref. PBS2540, adjustable from 25 to 500 mm, Ref. **GAC-PZA-PBS-PZS**



● Belt-type back gauge ④

Gauge equipped with 4 repositionable fingers over the length, setting of the gauge by digital counter ⑤, lateral control

- For folding machine Ref. PVS2050M adjustable gauge from 5 to 500 mm, Ref. **PVSB2040**
- For folding machine Ref. PVS3080MR adjustable gauge from 5 to 750 mm, Ref. **PVSB3080**
- For folding machines Ref. PVX2040, Ref. PVX2040T, Ref. PVX2040PE, Ref. PVX2040TPE, adjustable gauge from 5 to 750 mm, Ref. **PVXBC2040**
For folding machines PVX3080, Ref. PVX3080T, Ref. PVX3080PE, Ref. PVX3080TPE, adjustable gauge from 5 to 750 mm, Ref. **PVXBC3080**
- For folding machines Ref. PVX2040, Ref. PVX2040T, Ref. PVX2040PE, Ref. PVX2040TPE, adjustable gauge from 5 to 750 mm, Ref. **PVXBC2040**
- For folding machine Ref. PZX2040, adjustable gauge from 5 to 750 mm, Ref. **PZXBC2040**



Additional equipment for PCA, PCX, PZX, PVX, PBS, PVS

WORKSHOP BENCH AND BACK TABLES

● Zinc workbench adapted to folding machine ⁶

Length 2 090 x 1 500 mm
Table with incorporated setting tools for metal sheet tracing
3 storage levels and 4 racks

- For folding machine Ref. PBS2040, Ref. ETB2040

Workshop bench equipped with cutting accessories and clamping beam with guide rail (OPTIONS)



● Back table for folding machine ⁷

Table equipped with full lengthwise tool
Integrated and adjustable sliding back gauge

- Length 2 000 mm x 1 280 mm

- For folding machine Ref. PCX2040A, Ref. ETBX2040C gauge stroke 45 to 1000 mm
- For folding machine Ref. PZX2040, Ref. ETBX2040 gauge stroke 60 to 1000 mm
- For folding machines Ref. PVX2040, Ref. PVX2040T, Ref. PVX2040PE, Ref. PVX2040TPE Ref. ETBX2040V gauge stroke 60 to 1000 mm

- Length 2 500 mm x 1 280 mm

- For folding machine Ref. PCX2540A, Ref. ETBX2540C gauge stroke 45 to 1000 mm
- For folding machine Ref. PZX2540, Ref. ETBX2540 gauge stroke 60 to 1000 mm



BEADING ACCESSORIES

● Beading accessory with gear train: 14, 16 or 18 mm Ø, type ABH and ABV

(Please specify the Ø upon order)

- For folding machine Ref. PCX1020 Ref. ABH14-1020 / Ref. ABH16-1020 / ABH18-1020
- For folding machines Ref. PCX2040A and PZX2040 Ref. ABH14-16-2040 / ABH18-2040
- For folding machines Ref. PCX2540A and PZX2540 Ref. ABH16-2540 / ABH18-2540
- For folding machine Ref. PCX3080A Ref. ABH16-3080 / ABH18-3080
- For folding machine Ref. PBS2040 Ref. ABH14-16-2040BS / ABH18-2040BS
- For folding machine Ref. PVS2050M Ref. ABH14-16-2040VS / ABH18-2040VS
- For folding machine Ref. PVS3080MR Ref. ABH16-3080VS / ABH18-3080VS
- For folding machines Ref. PVX2040, Ref. PVX2040T Ref. PVX2040PE, Ref. PVX2040TPE : Ref. ABV14-16-2040 / ABV18-2040
- For folding machines Ref. PVX3080, Ref. PVX3080T Ref. PVX3080PE, Ref. PVX3080TPE : Ref. ABV16-3080 / ABV18-3080

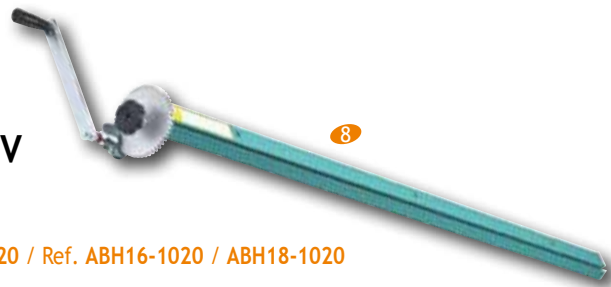

Capacity of beading accessory with gear train* (mm)	ABH/ABV			
	1020	2040	2540	3080
Ø 14	0,80	0,65	-	-
Ø 16	1,00	0,80	0,65	0,55
Ø 18	1,00	0,80	0,80	0,70

* Capacity zinc or copper (in mm)

● Beading accessory with gear train Ø 14, 16 mm type ABA (Specify the Ø upon order)

- For folding machine Ref. PCA2040 Ref. ABA2040



Zinc capacity (mm)	ABA2040
14-mm Ø rod (make a bead with 16-mm outer. Ø)	0,65
16-mm Ø rod (make a bead with 18-mm outer. Ø)	0,80

CUTTING ACCESSORIES

● RCS and RGS: Guide rails ⁹ (for CCM roller shear)

- For folding machine Ref. PCX1020 Ref. RCX1020
- For folding machine Ref. PCX2040A Ref. RCX2040A
- For folding machines Ref. PCX2540A and PZX2540 Ref. RCX2540A
- For folding machine Ref. PCX3080A Ref. RCX3080
- For folding machine Ref. PBS2040 Ref. RGS2040A



● Roller shear: CCM ¹⁰ (guide rail required)

- Handy, robust aluminum body
- Tempered steel rollers for a longer lifespan
- Guide rail and 2 grip handles for an accurate cut
- Capacity zinc 0,8 mm, steel 0,63 mm



● Guide rail: RCA, RZX and RVX ¹¹ (for roller shear CCMA)

- For folding machine Ref. PCA2040, Ref. RCA2040
- For folding machine Ref. PZX2040, Ref. RZX2040A
- For folding machine Ref. PVX2040, Ref. RVX2040
- For folding machine Ref. PVX3080, Ref. RVX3080



● Roller shear: CCMA ¹² (guide rail required)

- Handy, robust aluminum body
- Tempered steel rollers for a longer lifespan
- Guide rail and 2 grip handles ensure an accurate cut
- Capacity zinc 0,8 mm - steel 0,7 mm - 1050-H44 aluminum 0,8 mm



MISCELLANEOUS



● 180° Hem closing tool: OFP-180

for regular folding over the whole length

- From a seam at 135° it enables a plating at 180°
- Sets of 4 rollers
- Adjustable final roller for a perfect setting, according to material and thickness
- Folding capacity 0,8 mm steel



 YouTube
DEMONSTRATION VIDEO
available on YouTube® / Channel "Jouanel Industrie"

