

PDL

**PRESSA OLEODINAMICA
PER PIEGATURE**

PRESS FOR BENDING



| PDL.A



| PDL.S

PDL.A - COMANDO A PEDALE
RITORNO AUTOMATICO
PDL.A - CONTROLS BY PÉDAL
AUTOMATIC RETURN

PDL.S - SEMICICLO CON LEVA
PDL.S - SEMIAUTOMATIC BY LEVER

SICODAN®

Din forhandler af:

SICMI

PRESSE OLEODINAMICHE

PDL

PRESSA OLEODINAMICA PER PIEGATURE

PRESS FOR BENDING

CARATTERISTICHE

Punzone di piegatura e prisma a V, supporto mobile con 2 guide laterali, telaio monolitico, rete di protezione posteriore, supporti anteriori con asta millimetrata, stae di ssaggio del prisma e fori di registro.

UTILIZZO

Piegature.

COMANDI

CICLO CON PEDALE, microns di arresto discesa/salita, risalita automatica.
SEMICICLO CON LEVA e microns di arresto.

ACCESSORI

Pressostato, contapezzi, supporti millimetrati posteriori, lettura digitale per quote, supporti anteriori con riscontri regolabili.

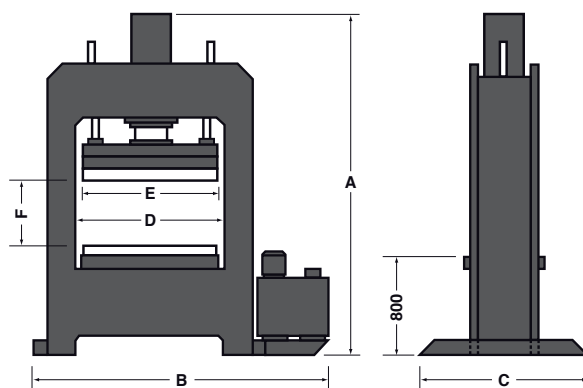

FEATURES

Bending punch and "V" prisma, movable support with 2 lateral slides, monolithic frame, protection grate on the back, front supports with millimetric bar, clamps for prisma and adjusting holes.

USE

Bending works.

CONTROLS

AUTOMATIC BY PEDAL, microns for up/downstroke stop, automatic table return.
SEMI-AUTOMATIC BY LEVER and microns for stop.

OPTIONALS

Pressure switch, piece counter, millimetric supports on the back, digital readout of dimensions, front supports with adjustable trucks.

MODELLO Model	Tonn.	A	B	C	D	E Punzone Punch	F	CORSA Stroke	VELOCITÀ AVVICINAMENTO mm/sec Approaching speed	VELOCITÀ LAVORO mm/sec Working speed	KW	PESO Weight kg
PDL 40	40	2200	1850	1050	900	835	250	500	9	9	4	1200
PDL 70	70	2300	1850	1050	900	835	250	500	10	5	4	1300
PDL 100	100	2300	2100	1050	1050	850	200	500	10	4	4	1900
PDL 100 B	100	2300	2650	1300	1550	1000	200	500	10	4	4	2600
PDL 100 C	100	2400	2650	1300	1550	1500	200	500	10	4	4	2700
PDL 150	150	2600	2700	1400	1550	1000	200	500	9	3	4	4300
PDL 150 C	150	2600	2700	1400	1550	1500	200	500	9	3	4	4500
PDL 200	200	2750	2750	1600	1550	1000	200	500	10	3	5,5	5900
PDL 200 C	200	2750	2750	1600	1550	1500	200	500	10	3	5,5	6300
PDL 300 D	300	3000	3300	1800	2000	1500	200	500	9	2	7,5	10300
PDL 400 D	40	3000	3400	1800	2000	1500	200	500	9	2	7,5	12000

Sicmi si riserva il diritto di apportare modifiche eventuali senza impegno di aggiornare il presente prospetto.
Sicmi reserves all rights to make any changes without obligation to update this specification.



SICMI S.R.L. - S. QUIRICO 43018 SISSA - TRECASALI (PARMA) ITALY VIA
IV NOVEMBRE, 35 - TEL. +39 0521 873346/44 - FAX +39 0521 872952
info@sicmi.it - www.sicmi.it

SICODAN[®]

SICMI

PRESSE OLEODINAMICHE