

Babylon Build Guide

Notes:

- Kit Includes
- 1x Babylon Case
- 1x Fr4 Plate
- 1x AD65 PCB - Solder ONLY. PCB is already VIA ready by default.
- 1x PCB Shims
- 2x Complete Gasket Sets
- 1x Complete Rubber Feet Sets
- 2x 70a NBR Orings (5in OD x 3/8in CS)
- 1x All necessary screws (4x M3x5mm Socket Head, 4x M2x3mm Pan Head)

Babylon Build Guide

Notes:

- Build Path needs to include all of the demonstrated steps, except 5B or 5C.
- One of the following, Steps 5B OR 5C, must be used to complete the build path. The other can be excluded if preferred.
- Mounting Methods
 - If 5B is used, and 5C excluded, Babylon is a Float-Mount configuration.
 - This configuration has more flex and bounce, but the plate is allowed to freely move inside the case.
 - Acoustics will be more poppy compared to Gasket.
 - If 5C is used, and 5B excluded, Babylon is a Gasket Mount configuration.
 - This configuration has less flex and bounce, but the plate is fixed by gaskets and will not move.
 - Acoustics will be more muted compared to Float.
 - If BOTH 5B and 5C are used, Babylon is a hybrid mount, retaining a mild poppy sound signature and more limited plate movement when typing.
 - IF **NEITHER** 5B or 5C are used, Babylon will not function.

STEP 1: Attach Daughterboard JST Cable and insert the Daughterboard into the Bottom Case.

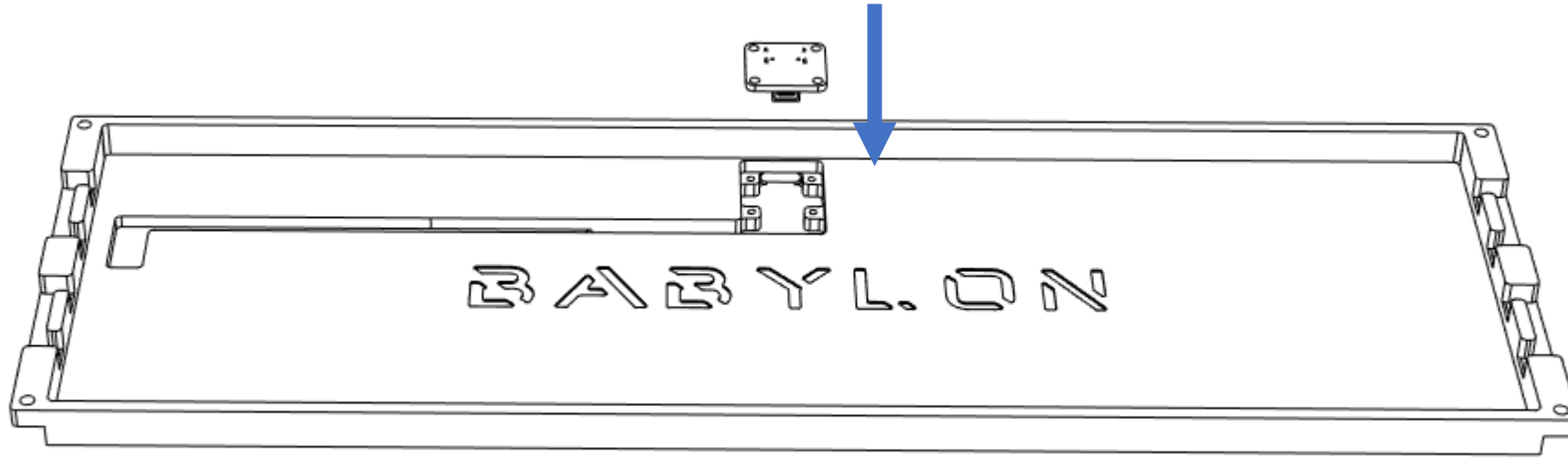

Notes:

- Daughterboard is secured with 4x provided M2x3mm Screws.
- It should be mounted Upside Down (as shown).

STEP 2: Attach Gasket Pads to the Bottom Case.

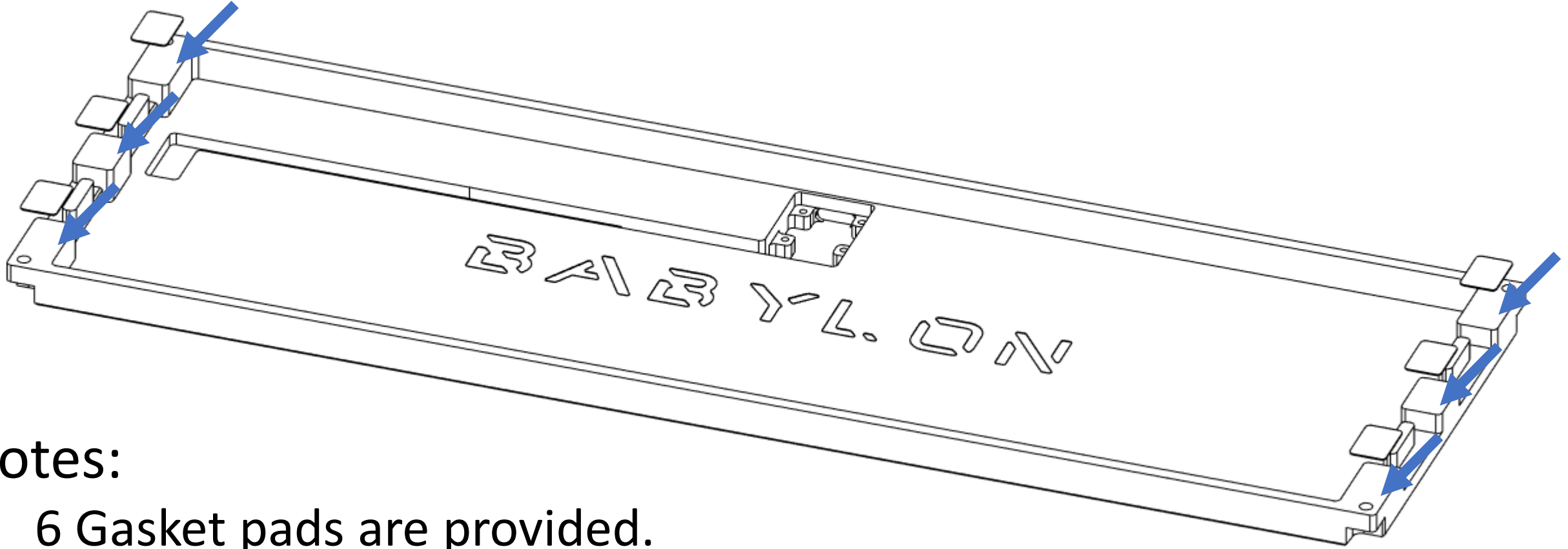

Notes:

- 6 Gasket pads are provided.
- Some gasket pads may still have paper attached to the back after removal. Use tweezers to remove these.
- This is similar to a “force-break” mod and deskey film pads can be substituted.

STEP 3: Attach PORON gaskets to the top case

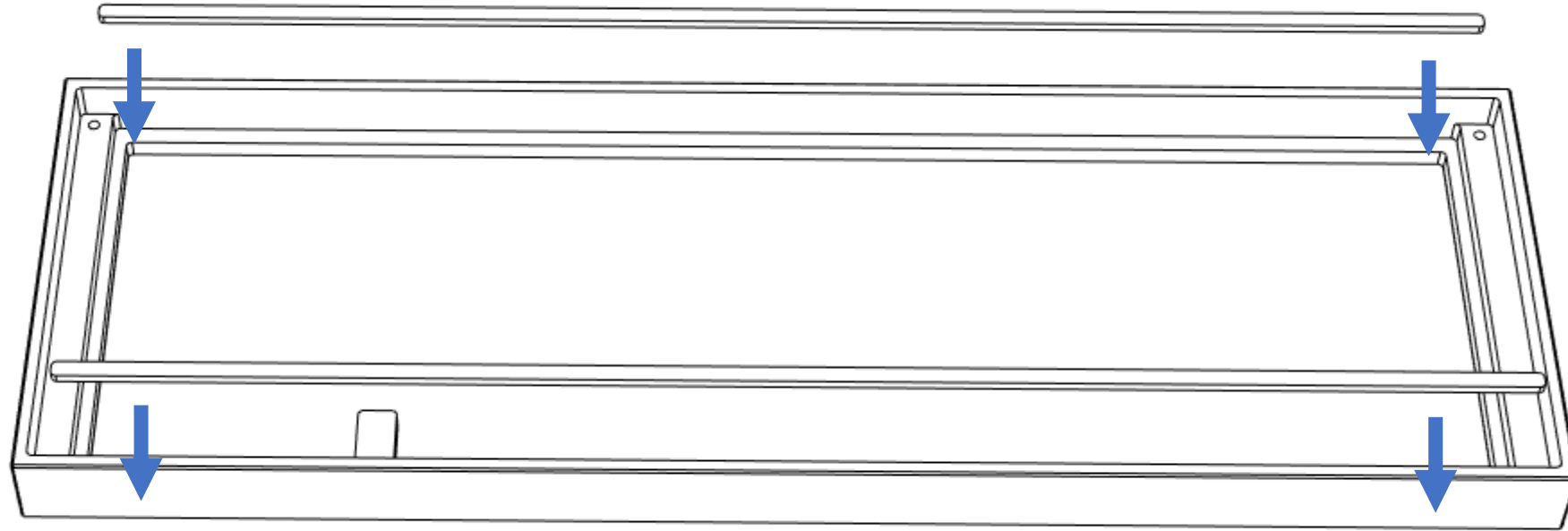

Notes:

- Gaskets are likely to stretch since they are so long. Any mishandling will stretch them.
- Stretching is ok. Just cut off the excess.

STEP 4: Assemble the PCB/Plate Assembly

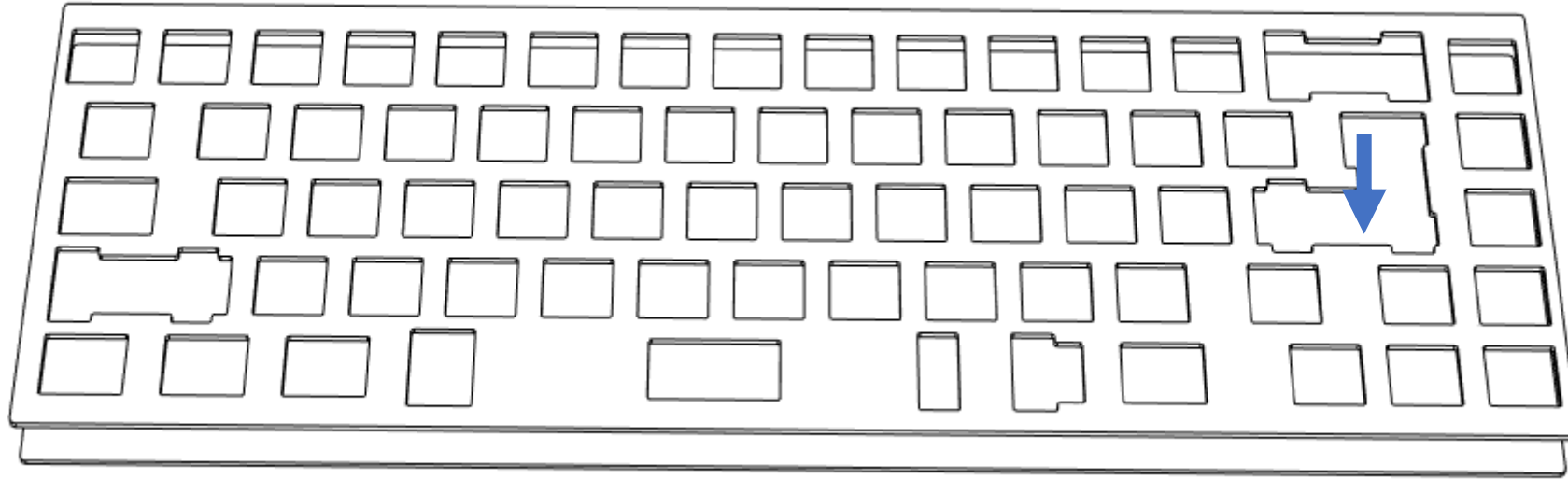

Notes:

- Supported Layouts: ANSI, ISO, Split BS & LS, 7u & 6.25u Spacebar
- Please remember to attach keycaps at this step too. This is the **BEST** time to attach keycaps.

STEP 5A: Apply the Supplied Super-Lube to both of the O-Rings.

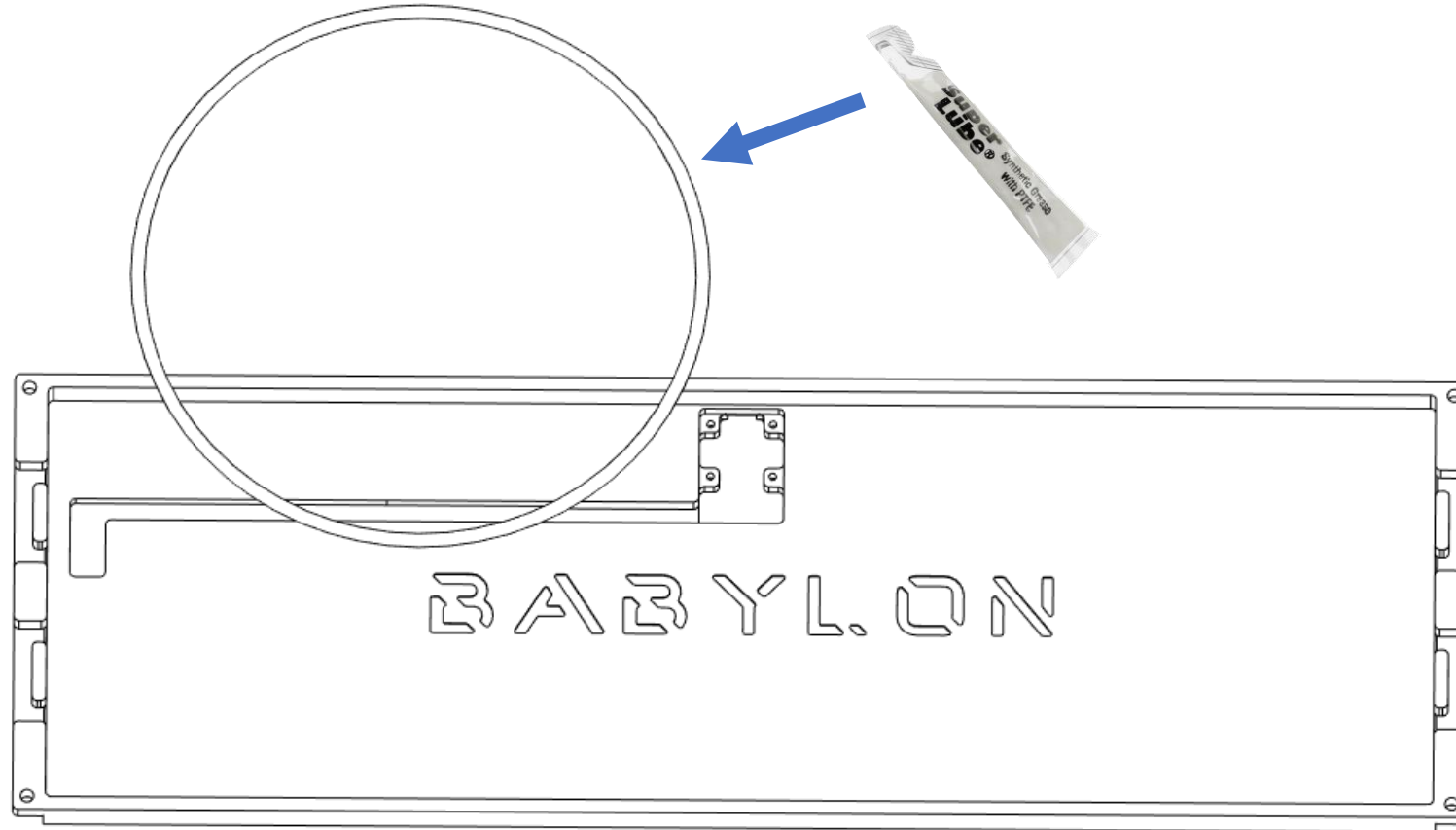

Notes:

- Apply a small (pea-sized) drop of super lube to the o-ring and spread across the surface.
- Super-Lube is supplied in the kit.

STEP 5B: Attach O-rings to the bottom case

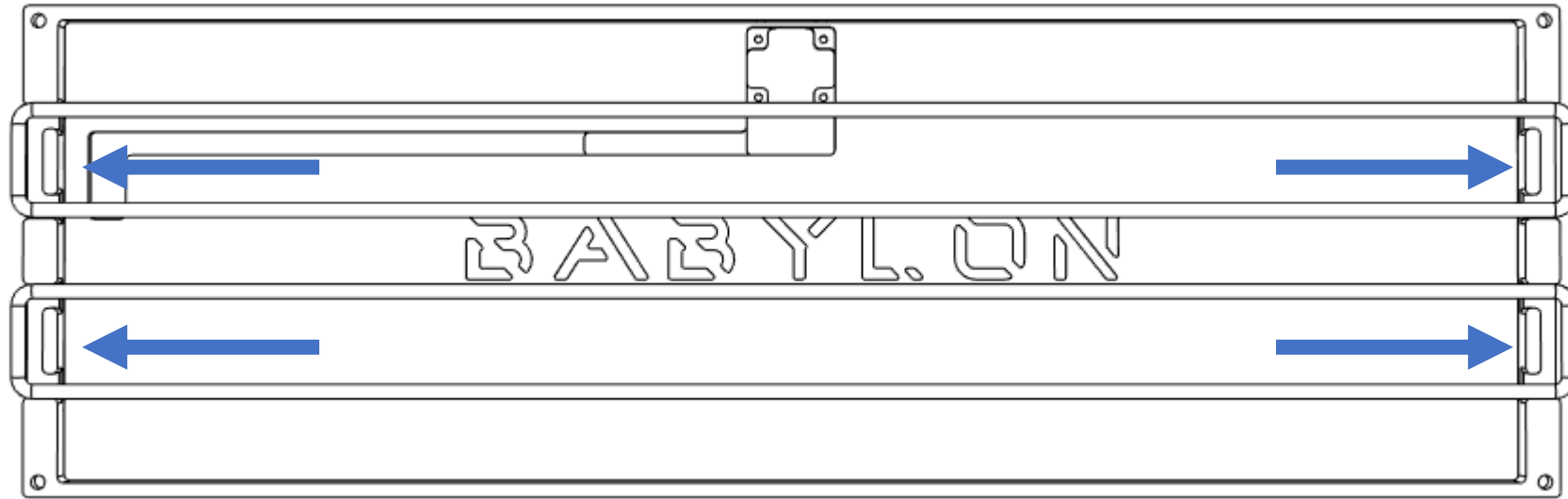

Notes:

- O-rings go around the pegs as shown.
- Give them a gentle stretch before attaching if having a difficult time. They are designed to fit tightly.

STEP 5C: Attach the Bottom Gaskets (OPTIONAL)

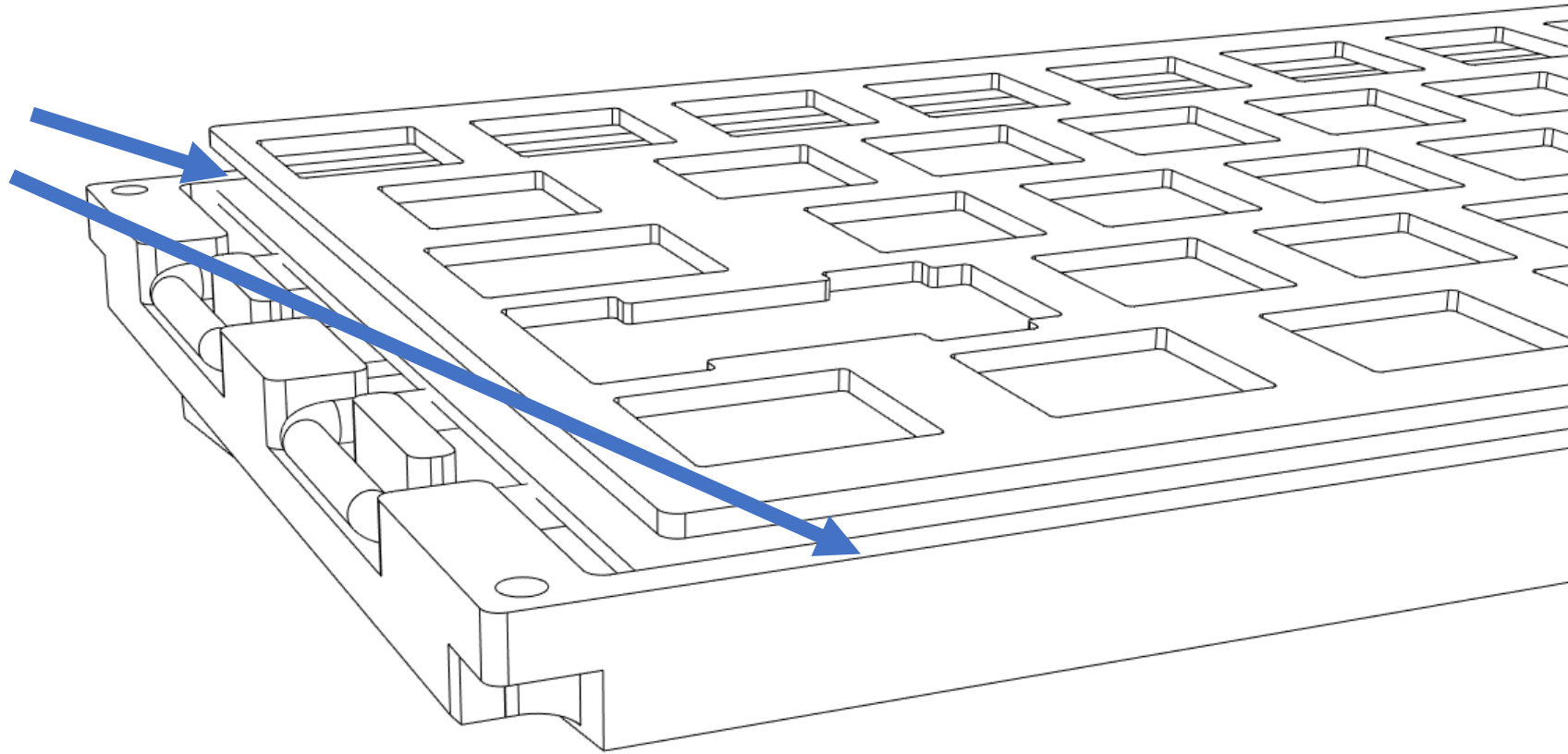

Notes:

- The bottom gasket is applied to the rails shown by the blue arrow.

STEP 6: Mounting the keyboard case together

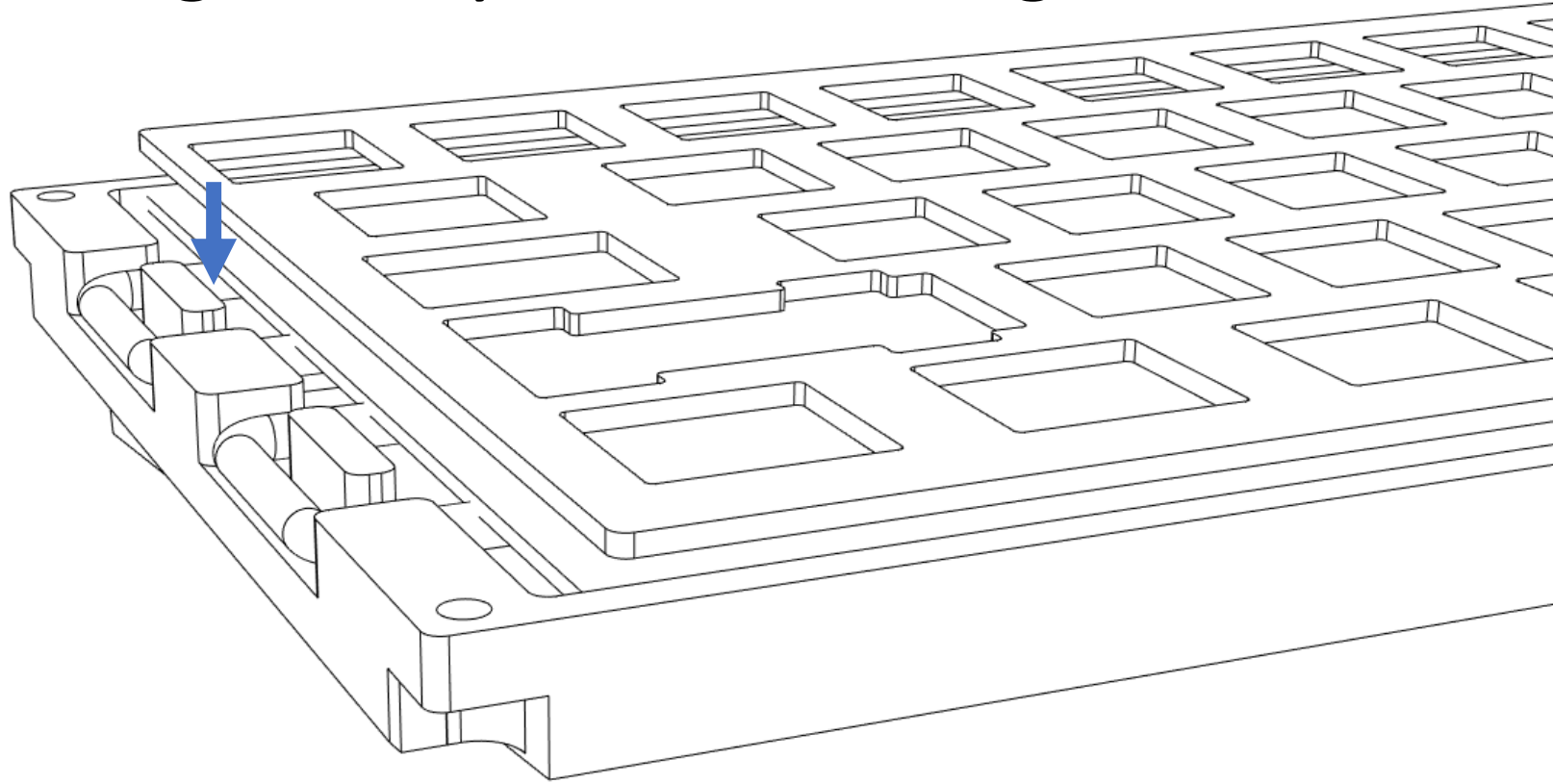

Notes:

- Remember to connect the JST.
- The JST connector will sit on top of 1 O-ring. This is the proper build position.

STEP 7: Closing the Keyboard

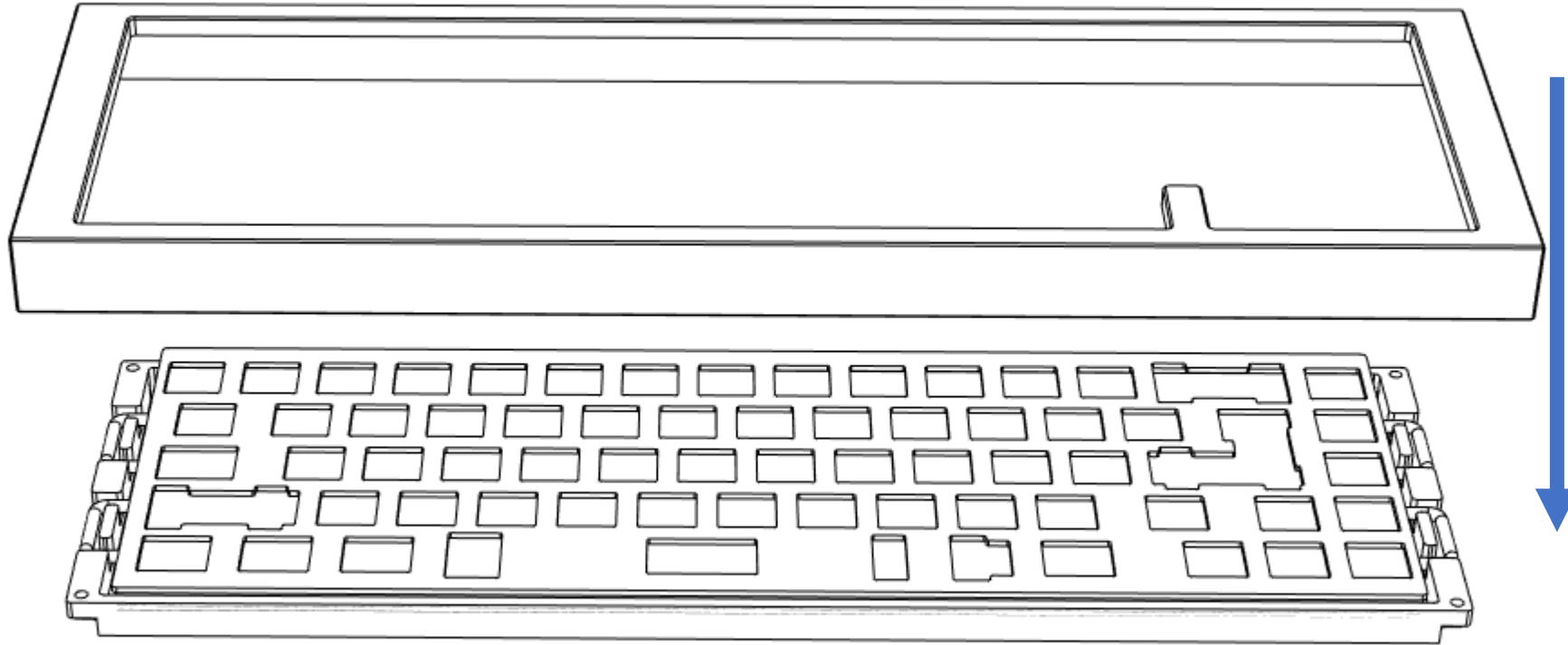

Notes:

- Gently close the top case as demonstrated from the top. Do not reverse the case yet.
- Make sure the blocker does not interfere with the keys. (This is why keycaps should be mounted already.)

STEP 8A: Prep the 4x M3x8mm by putting O-rings around each screw.

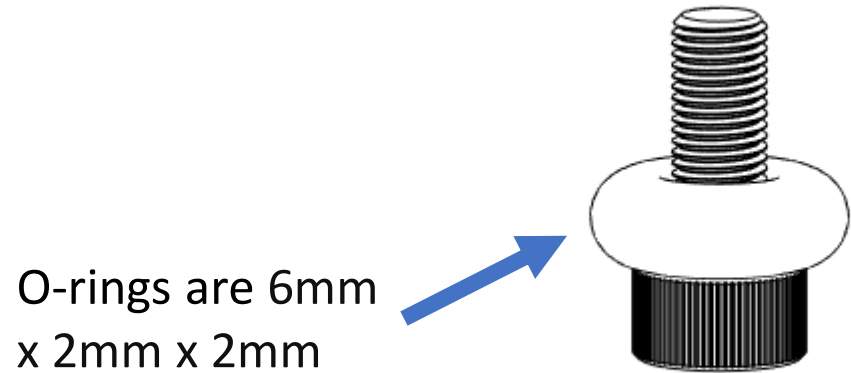

Notes:

- This step will already be completed upon receiving the case.
- Make sure the O-rings remain on the screws when assembly and disassembling.
- O-rings function to prevent overtightening of the screw.

STEP 8B: Screws to secure the top case.

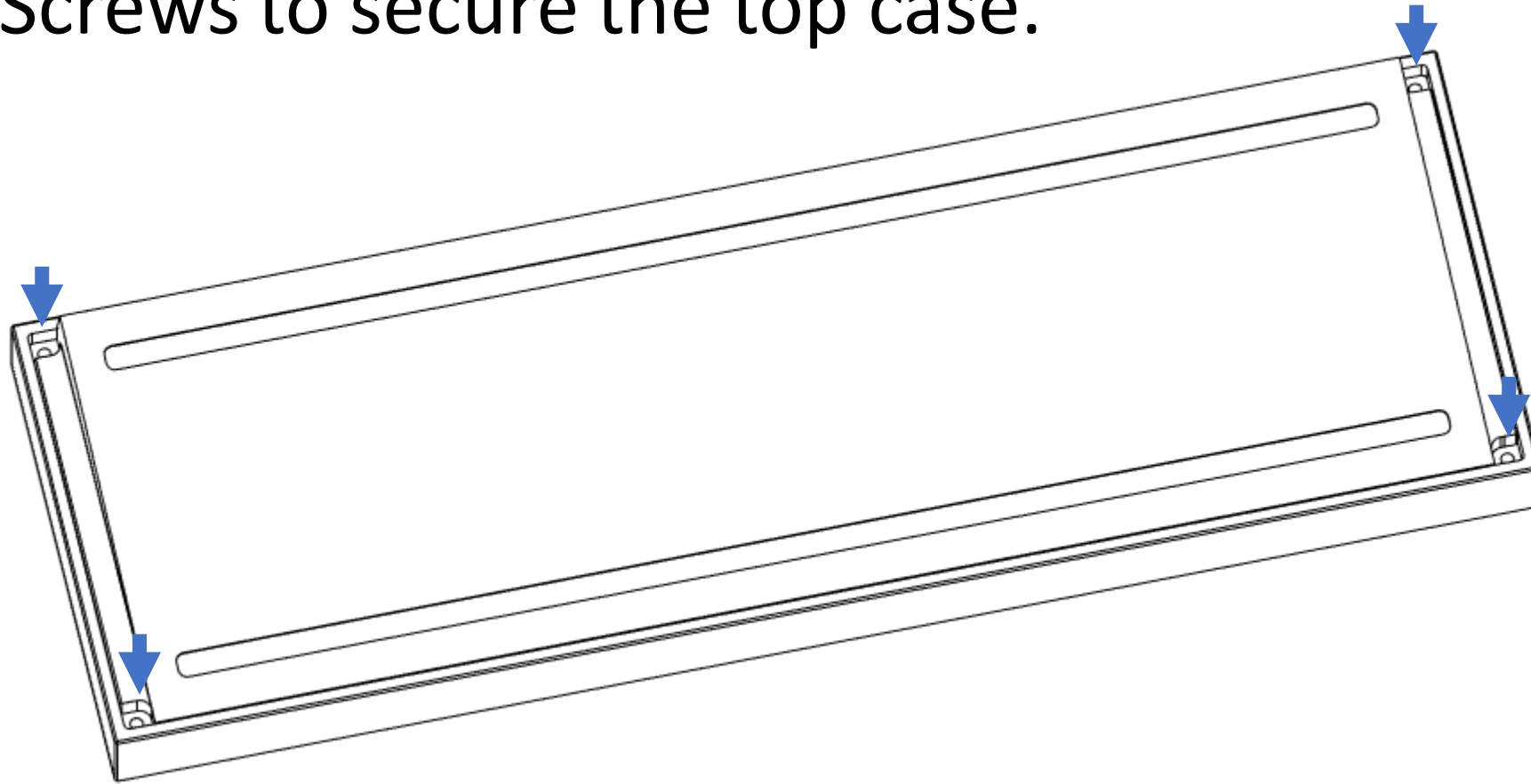

Notes:

- Hold the case together when flipping to prevent components from sliding.
- Tighten screws until the orings start to visibly compress, then stop.
- **Do not overtighten as this will cause negative effects to the build (ping and stiffness)**