



## Anthem Owner's Manual

APRIL 2024 | VERSION 1.4



# ANTHEM

## Owner's Manual

The Anthem is designed for use on paved roads only. Before taking your first ride, thoroughly read the owner manual and follow all instructions. The manual serves as a reference, so please consult your actual Anthem for information on appearance, functionality, and performance. To ensure optimal performance and longevity, use only Ryvid approved components and accessories on your motorcycle.

# Table of Contents

07	Anthem Details Worksheet	<b>25</b>	<b>Anthem Features and Controls</b>	<b>39</b>	<b>Storage and Accessories</b>	<b>89</b>	<b>Pre-Ride Checks</b>
07	An Important Message from Ryvid	25	Exterior Overview	<b>41</b>	<b>Additional Accessories Information</b>	<b>91</b>	<b>Carrying Capacity and Loading</b>
09	California Proposition 65	27	Controls	<b>45</b>	<b>Display</b>	91	General
09	California Perchlorate Advisory	29	Power Button	45	Display Indicators	93	Loading Guidelines
11	About this Manual	29	Motor Stop	45	Display Operation and Settings	93	Vehicle Range
11	Useful Information for Safe Riding	<b>31</b>	<b>Mode</b>	<b>47</b>	<b>Passive Keyless Entry and Security System Operation</b>	<b>95</b>	<b>Maintaining Your Anthem</b>
11	Emissions Information	31	Eco Mode	<b>49</b>	<b>Battery</b>	97	Periodic Maintenance Intervals
11	Parts and Accessories	31	Sport Mode	53	Charging and Maintaining Your Battery	103	Wheels and Tires
<b>13</b>	<b>General Safety Precautions</b>	33	Reverse	55	Charging Components	103	Tire Inflation
13	General Guidelines	33	Cruise Control	57	Charging Instructions (Battery Attached)	105	Tire Replacement
15	Important Operating Information	33	Seat Height Control	59	Charging Instructions (Battery Removed)	107	Brakes
17	Anthem Battery Conditioning	35	Hazard Flasher	61	Battery Life	107	Brake Fluid Replacement
<b>19</b>	<b>Important Placards and Markings</b>	35	Headlight High Beam / Low Beam	63	Battery Removal, Installation, and Handling	109	Cleaning your Anthem
19	Vehicle Identification Number (VIN)	35	Horn	65	Battery Lock	111	Tie Down Instructions
21	Vehicle Emission Control Information(VECI)	35	Turn Signals	67	Battery Reset	113	Parking and Long-Term Storage
23	Ryvid Motor Label	<b>37</b>	<b>Braking</b>	69	Removing, Moving, and Installing Battery	<b>111</b>	<b>Customer Information</b>
		37	Mechanical Braking	<b>85</b>	<b>Adjustable Seat</b>	115	Customer Assistance
		37	Regenerative Braking	<b>87</b>	<b>Suspension Settings</b>	117	Reporting Safety Defects
		37	Regen Button	87	Front and Rear Suspension, Suspension Log	<b>117</b>	<b>Video Instruction Links</b>

# Anthem Information

---

For your reference, use this page to record identifying information.

Vehicle Identification Number (VIN):

Battery Serial Number:

Motor Serial Number:

Key Code:

Date of Purchase:

# An Important Message from Ryvid

---

The team at Ryvid would like to extend our congratulations and appreciation for choosing to purchase an Anthem. You are now a part of the growing Ryvid community!

To ensure the best performance of your Anthem over its lifetime and that Ryvid can contact you if necessary, please be certain that your Anthem is registered with Ryvid. If you have questions, please contact Ryvid (see page 101 for contact info.)

It is crucial to read this manual thoroughly and completely before operating your Anthem motorcycle. The manual provides important information on operating, inspecting, and maintaining your Anthem. Please do not attempt to ride the Anthem until you have a detailed understanding of its controls and operating features and have received appropriate training in safe and proper riding techniques. Failure to follow these recommendations may result in the invalidation of your warranty.

Please note that this manual contains the latest product information available at the time of printing. Due to ongoing development and the complexities of modern manufacturing, there may be slight variations in your Anthem compared to the information provided in this manual. Any discrepancies cannot be used as grounds for legal claims.

As this manual may be updated periodically, you may download the most recent version at [www.ryvid.com/manuals](http://www.ryvid.com/manuals).

If you have any questions or concerns about operating or maintaining your Anthem, please do not hesitate to contact Ryvid directly.



## California Proposition 65

---

**WARNING:** Operating, servicing, and maintaining a motor vehicle can expose you to chemicals including phthalates and lead, which are known to the State of California to cause cancer and birth defects or other reproductive harm. To minimize exposure, wear gloves or wash your hands frequently when servicing your vehicle.

For more information go to: [www.P65Warnings.ca.gov/passenger-vehicle](http://www.P65Warnings.ca.gov/passenger-vehicle).

## California Perchlorate Advisory

---

**WARNING:** Certain components of this Ryvid Anthem such as lithium batteries may contain perchlorate material. Special handling may apply for service or end of life disposal.

See [www.dtsc.ca.gov](http://www.dtsc.ca.gov).



## About This Manual

---

This manual covers the features and operation of the Ryvid Anthem motorcycle. The terms “right” or “left” reference right or left as viewed by a rider seated on the Anthem.

## Useful Information for Safe Riding

---

This manual contains two important words, which require extra attention while reading:

**WARNING:** Indicates something that could injure you or others.

**CAUTION:** Indicates things that could damage your motorcycle.

## Emissions Information

---

The Ryvid Anthem is a true freeway-capable, zero emissions vehicle under California Air Resources Board (CARB), U.S. Federal Environmental Protection Agency (EPA), and European Union standards. It uses no gasoline or other liquid fuel. It has no tailpipe and therefore no tailpipe emissions. It also has no exhaust or evaporative emissions.

## Parts and Accessories

---

**CAUTION:** We recommend that you only use parts and accessories that have been approved by Ryvid for your motorcycle. Approved parts and accessories for your Ryvid Anthem have been thoroughly inspected and tested for safety and compatibility. Ryvid is not responsible for any damage caused by the use of non-approved parts and accessories for your Anthem motorcycle. Contact Ryvid or visit [www.ryvid.com](http://www.ryvid.com) for information on purchasing Ryvid-approved parts and accessories.



# General Safety Precautions

## General Guidelines

- The Ryvid Anthem is a powerful motorcycle that requires extreme caution when operating.
- To reduce the risk of injury, wear the proper safety gear, including a helmet, eye protection, riding boots, gloves, and protective clothing.
- We strongly recommend wearing protective clothing at all times, even for short rides and in all seasons.
- Before operating the motorcycle, read all warnings and product instructions in the owner's manual and safety labels on the Anthem.
- Never allow anyone to ride your motorcycle without proper instruction, and never operate the motorcycle under the influence of alcohol or drugs.
- Those who are unwilling or unable to take responsibility for their actions should not use this motorcycle.
- Before each ride, the rider should check the "every ride" column of the maintenance schedule and the charge level of the battery as indicated on the dash display.
- Keeping the motorcycle in good mechanical condition is crucial for safety, so be sure to follow the maintenance schedule and adjust requirements in this manual.

## Important Operating Information

---

### WARNING:

- Modifying the Anthem can make the motorcycle unsafe and may result in severe injury. Ryvid is not responsible for non-approved alterations or modifications.
- Be cautious when loading or adding accessories to the motorcycle as large, bulky, or heavy items can negatively impact the handling, performance, and the effectiveness of the motorcycle's safety systems.
- When not actively riding, ensure that the Anthem's motor stop button is toggled to "stop", or the kickstand is down to avoid accidental throttle input activating the motor
- **Due to the motorcycle's silent idle state, it is possible to forget that the motorcycle is powered up, so always toggle the motor stop button to "stop" to disable the throttle when getting on and off the bike.**
- When pushing the Anthem while dismounted, make sure to toggle the motor stop button to "stop", to prevent unexpectedly activating the motor with the throttle.

## Important Operating Information

---

### CAUTION:

- When stopping on an incline, do not prevent rollback using the throttle, as this generates heat in the motor that can reduce electrical component life, and waste energy discharging battery. Instead, use the foot brake to prevent rollback.
- Use only approved chargers and adapters with your Ryvid Anthem.
- Only charge the Anthem battery with the Ryvid provided charger or an approved charge accessory.
- The battery does not require nor benefit from deep discharging. Leaving a battery in a discharged state will cause damage.
- Failure to follow battery storage and charging instructions as described in this owner's manual may damage the battery and would not be covered under warranty.





## Important Battery Conditioning

**CAUTION:** Battery conditioning and balance is of the utmost importance. Before riding, it is necessary to fully charge your battery on receipt of your Anthem, or after any period of storage longer than 15 days.

A full charge is 85.3+ or more volts indicated on the display. During shipping or storage of 15 days or longer, slight imbalance can develop between the cells of the battery pack. While charging, when the battery is in this state, the charger fan may turn off, and the display may indicate "100%" before the battery has completely charged and balanced. This is because the battery is entering a balancing phase of the charge, topping off each individual cell and ensuring battery health. Before riding, please charge your Anthem for a full 4+ hours (110V) or 2.5 hours (220V) and an indicated 85.3+ volts.

- For the first 5 cycles when new.
- At least one cycle after storing the bike for 15 days or more.

Additionally, it is best to avoid deep discharge during these initial 5 charges, so charging when the bike is at 25% State of Charge (SOC), or more is the best practice during these conditioning cycles. This is also recommended for the first charge cycle following a period of storage. Following this guidance will ensure the best lifespan of your battery and avoid errors in the SOC indication that could lead to inaccurate range or remaining energy estimates.



# Important Placecards and Markings

## Vehicle Identification Number

The following breakdown of the VIN will help you understand the significance of each digit or character in case you need to reference it when contacting Ryvid or ordering parts.

VIN Digit	1	2	3	4	5	6	7	8	9	10	11	12	13	14	15	16	17
Code	WMI: World Manufacturer Index			Make: Ryvid = R	Model: Anthem = A	Type: Motorcycle = M	Engine Type: Electric = E	Net HP: 11HP = F	Check Digit:	Model Year: 2023 = P	Plant of Manufacture: Ryvid Inc = F	Sequence of Manufacture					
Anthem Sample VIN	7	U	J	R	A	M	E	F	4	P	F	0	0	0	0	0	1

**MANUFACTURED BY: RYVID INC.**

**AUGUST 2023**

**ANTHEM**

**GVWR** 292 KG (643 LB)

**GAWR FRONT** 125 KG (275 LB) WITH M120/70R17 TIRE, 17xMT4.00 RIM AT 241KPA 35PSI COLD

**GAWR REAR** 167 KG (368 LB) WITH M160/60R17 TIRE, 17xMT4.50 RIM AT 241KPA 35PSI COLD

THIS VEHICLE CONFORMS TO ALL APPLICABLE US FEDERAL MOTOR VEHICLE SAFETY STANDARDS IN EFFECT ON THE DATE OF MANUFACTURE SHOWN ABOVE

**VIN: VIN NUMBER LOCATED HERE TYPE: MOTORCYCLE**

# Vehicle Emissions Control Information

<b>ANTHEM</b>	<b>VEHICLE EMISSION CONTROL INFORMATION</b>
	
<b>TEST GROUP</b>	<b>CODE LOCATED HERE</b>
<b>FUEL</b>	<b>BATTERY-ONLY ELECTRIC VEHICLE</b>
THIS VEHICLE CONFORMS TO US EPA REGULATIONS APPLICABLE TO 2023 MODEL YEAR NEW MOTORCYCLES	

(1) The manufacturer of any motorcycles shall, at the time of manufacture, affix a permanent, legible label, of the type and in the manner described in this section, containing the information provided in this section, to all production models of such vehicles available for sale to the public and covered by a certificate of conformity.

(2) A permanent, legible label shall be affixed in a readily accessible position. Multi-part labels may be used.

(3) The label shall be affixed by the vehicle manufacturer who has been issued the certificate of conformity for such vehicle, in such a manner that it cannot be removed without destroying or decasing the label, and shall not be affixed to any part which is easily detached from the vehicle or is likely to be replaced during the useful life of the vehicle.

(4) The label shall contain the following information lettered in the English language in block letters and numerals, which shall be one of a color that contrasts with the background of the label:

1	2	3	4	5	6	7	8	9	10	11	12
Model Year Code	EPA Mfg COde			Ind. Sector Code	Battery Type Code				Mfg Defined Code		
P	R	Y	V	C	L	I	O	N	A	N	T
2023	Ryvid			Highway Motorcycle	Lithium Ion				Anthem		



## Ryvid Motor Label

The motor serial number is located on the Ryvid motor label.  
The motor number may be needed for registration in some states.

 **Ryvid**

**ELECTRIC HYPER ENGINE**

 **M 0.104266**

**MOTOR NUMBER RA00001**

**RATED POWER 7.5 Kw PEAK POWER 14 Kw VOLTAGE 72V**

# Anthem Features and Controls

## Exterior Overview

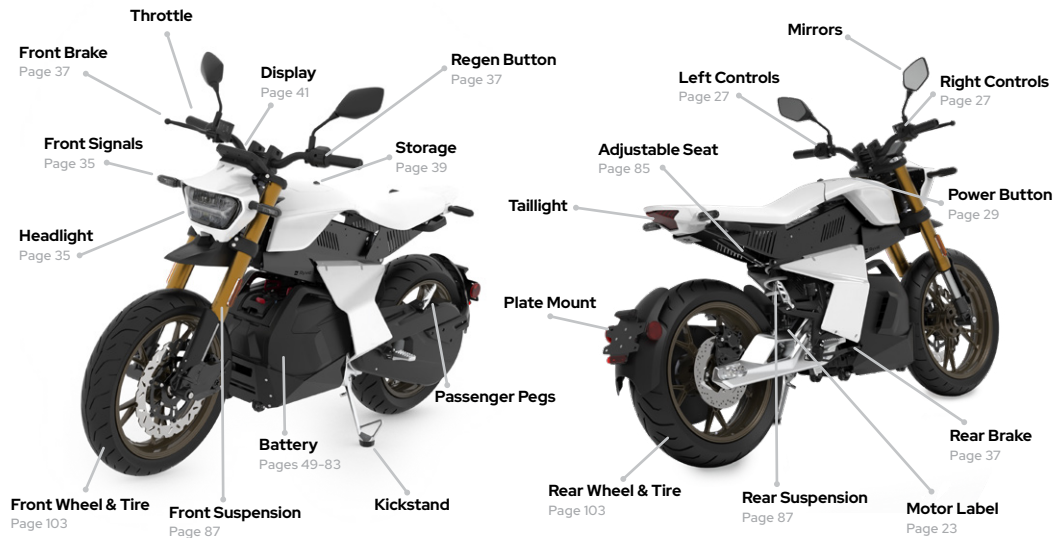

# Controls

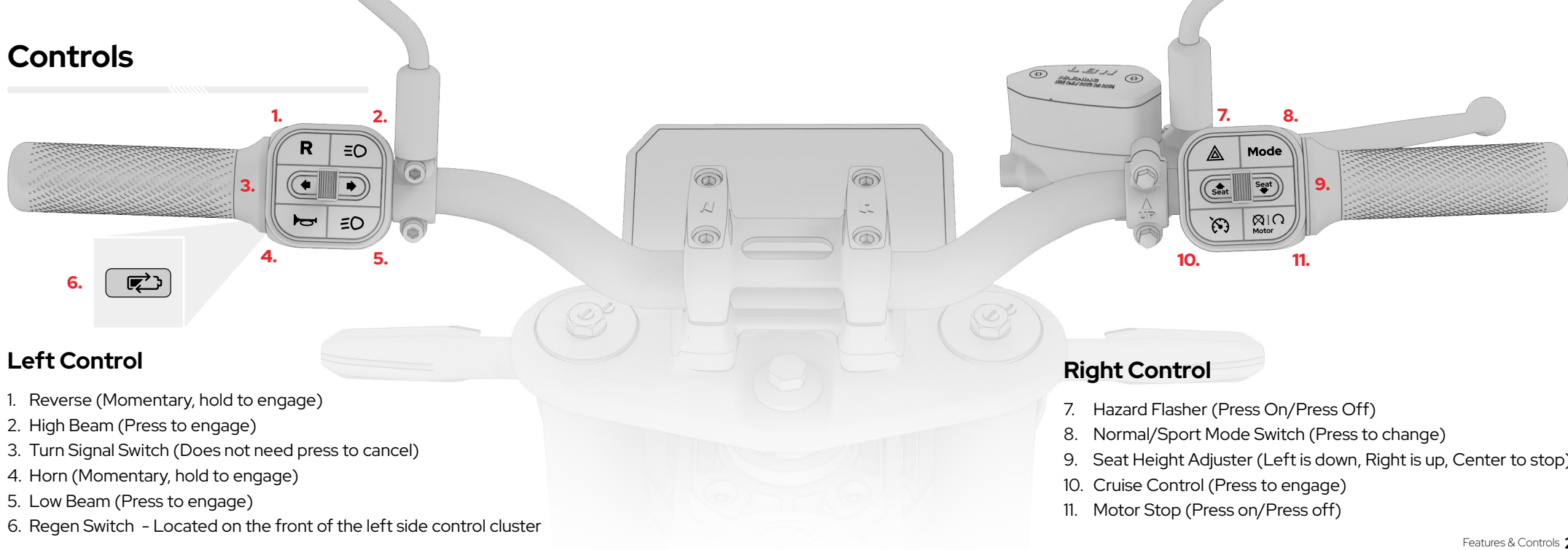

## Left Control

1. Reverse (Momentary, hold to engage)
2. High Beam (Press to engage)
3. Turn Signal Switch (Does not need press to cancel)
4. Horn (Momentary, hold to engage)
5. Low Beam (Press to engage)
6. Regen Switch - Located on the front of the left side control cluster

## Right Control

7. Hazard Flasher (Press On/Press Off)
8. Normal/Sport Mode Switch (Press to change)
9. Seat Height Adjuster (Left is down, Right is up, Center to stop)
10. Cruise Control (Press to engage)
11. Motor Stop (Press on/Press off)





## Power Button

The Power button is used to power on and off the Anthem. The power button has an indicator light around the circumference of the button to show if the Anthem is powered on or off. When the Anthem is powered off, the indicator light will be extinguished. When the Anthem is powered on, the indicator light will illuminate.

When the Anthem is powered on, the drive motor and throttle will be set (inactive or active) based on the last known condition when the Anthem was powered off. The drive motor condition is set with the Motor Stop button described below.

Also note that the Anthem will always default to Eco Mode ("E") upon powering on.



## Motor Stop

The Motor Stop button will stop the motor from receiving power to drive the motor and deactivate the throttle functionality. The motor and throttle can be activated by pressing the Motor Stop button again.

Upon powering on the Anthem, the throttle and motor will be set to the last known condition when the Anthem is powered off.

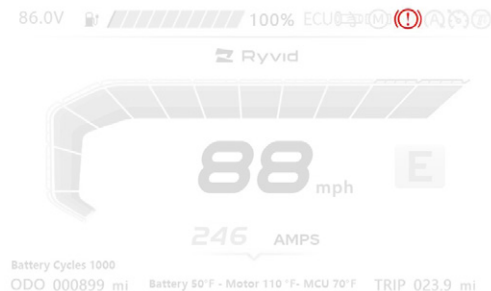

# Mode



## Eco Mode

In this mode, the motor's current is limited to 74 Amps, which will limit acceleration while still allowing the vehicle to reach its maximum speed. The actual top speed may vary, influenced by factors such as the rider's weight, wind conditions, terrain slope, and the battery's state of charge.

Toggle from Sport Mode to Eco Mode by pressing the "Mode" button. A green "E" will be indicated on the display when in Eco Mode.

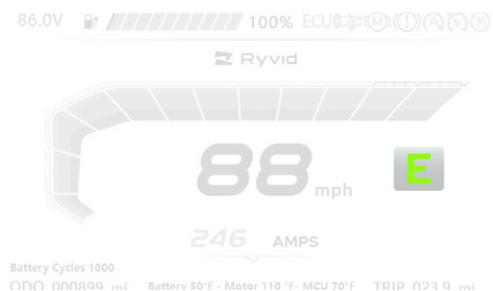

## Sport Mode

Sport Mode ("S") unlocks the maximum performance of the Anthem. This allows quicker acceleration and a higher top speed than Eco Mode. Note that riding in Sport Mode will reduce your overall range relative to Eco Mode.

Toggle from Eco Mode to Sport Mode by pressing the "Mode" button. A red "S" will be indicated on the display when in Sport Mode.

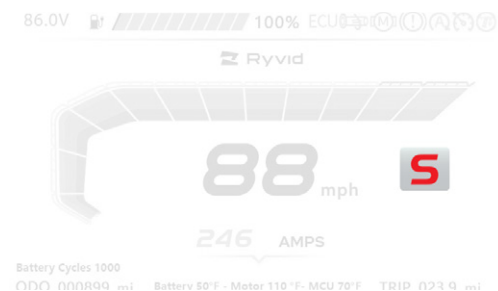



## Reverse

Press and hold the “R” button while turning the throttle to move the Anthem in reverse. Speed and torque are limited in this mode. A red “R” will appear on the display when in reverse. Release the “R” button to resume normal operation.



## Cruise Control

Press the Cruise Control button to activate Cruise Control and hold the current speed. Actuating either brake or pressing the Cruise Control button again deactivates the feature.



## Seat Height Control

The Anthem’s seat height can be commanded up or down with this three-position switch. See page 85 for more details on the functionality and control of this feature.



## Hazard Flasher

Pressing the Hazard Flasher button will flash both front and both rear turn signals simultaneously. Pressing the Hazard Flasher button again deactivates the feature.



## Low Beams

The low beam switch controls the low intensity headlight beam. Additionally, the headlight is equipped with Daytime Running Lights (DRLs) that are always on when the bike is on and cannot be turned off. It is recommended to leave the low beam on in addition to the DRL's for all riding conditions. Note that the low beam switch becomes disabled when the high beam is activated.



## High Beams

The high beam switch controls the high intensity headlight beam. With the low beam in the off position, activating the high beam switch will turn on and off both low and high beams simultaneously. With the low beam in the on position, activating the high beam will turn on and off the high beam independently. Activating the high beam switch disables the functionality of the low beam switch.



## Headlight Adjustment

The angle of the Anthem headlight can be adjusted by turning the adjuster knob, located under the headlight and above the front fender.



## Horn

Pressing the Horn button will sound the horn.



## Turn Signals

Left and right turn signaling is accomplished with a three-way toggle switch (left – off – right). The turn signal will continue to blink until the toggle switch is moved to the center/off position.

# Braking



## Mechanical Braking

The right brake lever activates the mechanical brake on the front wheel. The right foot pedal activates the brake on the rear wheel.

## Brake-Throttle Interlock

To protect the electrical system, the Anthem is equipped with a brake-throttle interlock. This prevents the motor from receiving power when either front or rear brake is activated.

Front Brake

Rear Brake



## Regenerative Braking

Regenerative braking allows for the recovery of electrical energy during braking by using the electric motor as an electric generator, which slows down the motorcycle.

In the Anthem, regenerative braking (known as regen) is automatically applied in Eco Mode ("E") when the throttle is closed. In Sport Mode ("S"), regenerative braking is not automatically applied when the throttle is closed. Regen can be activated in Sport Mode by activating either front or rear mechanical brake or by pressing the Regen Button.

## Regen Button

The Regen Button is only active when in Sport Mode ("S"). In Sport Mode, there is no automatic application of regenerative braking when the throttle is closed like there is in Eco Mode ("E"). However, sometimes recovering power during braking is desired in Sport Mode, which is made possible by the Regen Button.



## Storage and Accessories

---



### Miscellaneous Storage

The Anthem is equipped with a small storage compartment for miscellaneous items. The storage compartment is lockable by key and has a USB 2.0 for charging electronics.



### Accessories Mounting

The Anthem's frame has 4 pre-threaded, M6 holes on each side of the frame for mounting various accessories.

## Power Controller Controls

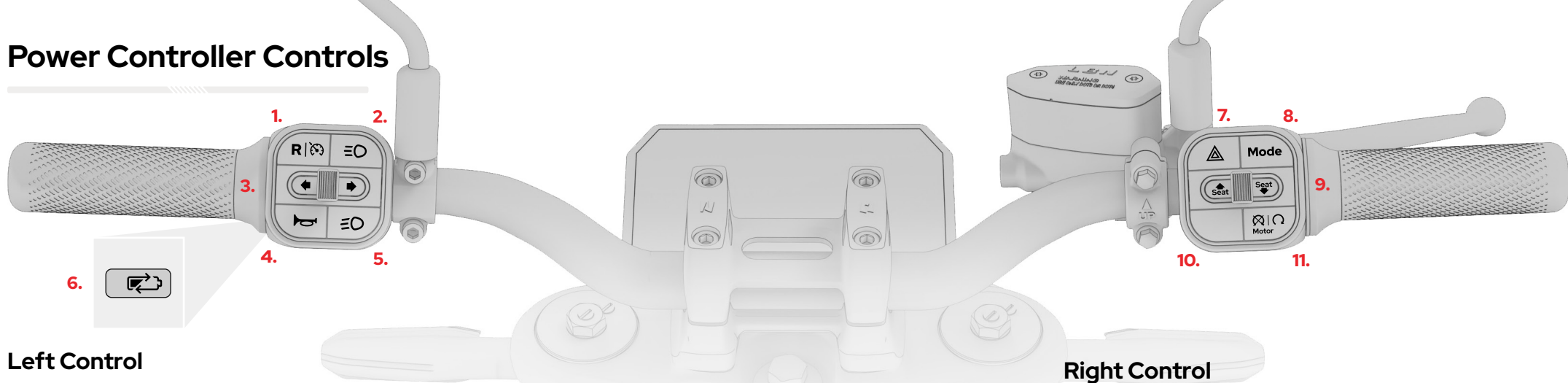

### Left Control

1. Reverse / Cruise Control (Press to engage, see following page for details)
2. High Beam (Press to engage)
3. Turn Signal Switch (Does not need press to cancel)
4. Horn (Momentary, hold to engage)
5. Low Beam (Press to engage)
6. Regen Switch - Located on the front of the left side control cluster

### Right Control

7. Hazard Flasher (Press On/Press Off)
8. Normal/Sport Mode Switch (Press to change)
9. Seat Height Adjuster (Left is down, Right is up, Center to stop)
10. Unused
11. Motor Stop (Press on/Press off)

## Power Controller Controls



### Reverse / Cruise Control

While stopped, press and hold the “R/CC” button while turning the throttle to move the Anthem in reverse. Speed and torque are limited in this mode. A red “R” will appear on the display when in reverse.

Release the “R” button to resume normal operation.

While in motion over 5MPH, press the “R/CC” button to activate Cruise Control and hold the current speed. Activating either brake or pressing the Cruise Control button again deactivates the feature.



### Right Hand Control

The bottom left button on the right hand control no longer has a designated function due to the combination of the reverse and cruise control.

# Display Indicators



**Turn Signal Indicators** – Visible when turn signal(s) in use.

**High Beam Indicator** – Visible when high beam is active.

**Brake Indicator** – Visible when brake(s) in use, or when motor-stop switch is activated.

**Cruise Indicator** – Visible when cruise control is active.

**Kickstand and Battery Switch Indicator** – Visible when the kickstand is down, or when the battery release latch is open.

**Low State of Charge Warning Indicator** – Visible if the battery state of charge falls below 20%.

**Controller Warning Indicator** – Visible in the event of a controller fault.

**Motor Warning Indicator** – Visible if there is an issue with the motor.

**Throttle Warning Indicator** – Illuminates in the event of a throttle problem.

**High Temp Warning Indicator** – Visible if the battery, motor, or controller overheat.

Corresponding indicator on display will turn red.

**WARNING:** If the controller warning is visible, do not ride your Anthem. These warnings indicate a fault in the system that could prevent the Anthem from operating normally.

Resolution: In some cases, these warning indicators can be cleared by cycling the power while safely at a stop. When doing so, ensure that the throttle is fully closed. If this fails to clear the warning, or if the warning reoccurs repeatedly after clearing, contact Ryvid Service.

**Unused Indicators** – Please note that there are unused indicators on the display.

They are blanks and will not illuminate.

## Display Operation and Settings

- Change units from Miles to Kilometers: During the startup screen (Ryvid logo on a black background) press and hold the lower left button (⚙️) for at least 3 seconds.
- Toggle day/night display mode: Press and hold the lower left button (⚙️) anytime during normal.
- Reset the trip odometer: Press and hold the lower right button (⌛) for at least 3 seconds.



## Passive Keyless Entry and Security System Operation

The Anthem features a Passive Keyless Entry system or “PKE,” which is used to activate the motorcycle for riding, and to arm the alarm system when parked. The alarm can be set manually or set to turn on automatically after 5 seconds when parked.

Desired Alarm Action	Required User Steps
Remote Power On	Short press then hold the “mute” button to remotely power on the Anthem
Lock the Anthem with an audible alarm	Short press the arming button on the remote one time. The alarm unit will make a single tone to confirm it is armed. If the bike is disturbed or moved in this state, the alarm will sound.
Lock the Anthem with a silent alarm	Short press the mute button on the remote. The alarm unit will produce a tone to indicate the mute state, then become silent. In this state, the bike is locked and cannot be turned on but will not produce an audible alarm tone when disturbed.
Unlock/Disarm the Anthem alarm	Short press the disarm button on the remote one time. This will disarm the alarm and unlock the Anthem for use.
Automatically arm the alarm	After the Anthem is turned off for 5 seconds, the alarm will make a single tone, and will automatically lock the motorcycle preventing tampering. If the bike is moved or disturbed, the alarm will sound.
Enable/disable Automatic alarm system	With the Anthem turned off, press, and hold the arming button on the remote for 3 seconds. The alarm will beep twice to indicate the automatic alarm is enabled. Press and hold for 3 seconds again, and the alarm will produce a long tone, indicating the function is disabled.





# Battery

## Battery Warning

**WARNING:** When charging your Anthem, always prioritize safety and follow these precautions to avoid potential risk of electrical shock:

- Use Ryvid-provided charging equipment or third-party equipment approved for use by Ryvid. Please direct third-party equipment questions to [hello@ryvid.com](mailto:hello@ryvid.com).
- Do not use charging equipment if it shows any sign of damage such as frayed or exposed wires.
- Do not probe, tamper with, cut, or modify high voltage cables or wiring.
- Never handle charging equipment or battery with wet hands or stand in water while charging.
- Ensure the power source (i.e., home electrical outlet) is properly rated to handle the electrical load of charging.

## Battery Safety Warning

---

- Keep the battery away from fire, heat, or water.
- Dismantling or disassembling the battery is prohibited.
- Extreme vibration, impaction, or compression is prohibited.
- **WARNING:** Do not squeeze, drop, puncture, disassemble, or short circuit the battery. It will lead to irreversible damage and may cause injury or death.
- Keep the battery away from children.
- Keep away from high pressure water spray and do not immerse the battery fully in water.
- If purchase an additional battery, do not use battery packs in multiple series or parallel, the Anthem is designed for one battery only.
- Do not use the battery pack with an exterior case rupture, damaged cells or malfunctioning BMS.
- If the battery has an abnormal noise, smell, rupture, deformation, color change, signs of melting, heat, or water inflow, please notify Ryvid and stop usage of the battery immediately. Place the battery in an open space outside, away from people and pets.

# Charging and Maintaining Your Battery

Proper maintenance of the Anthem's battery is critical for its longevity. To help you maintain your battery, Ryvid offers the following guidelines for proper charging and usage:

- **CAUTION:** If the battery is completely drained, it must be charged within 24 hours to avoid damage.
- If you ride frequently but do not use most of the battery's capacity, it is better to avoid charging it to 100% unnecessarily. Going for a few rides before recharging will prolong the battery's life by limiting the amount of time it spends at a high state of charge (over 80% SOC). It is not necessary to stop at exactly 80%, but storing or leaving the battery at less than full charge is the best practice.
- When the battery is intended to be stored for a prolonged period (more than one month), reduce SOC to 50%, to reduce storage degradation. The battery also should be checked every 3 months and ensure that the voltage is at or close to 75V. (50% state of charge)
- Storage temperature and humidity:
  - 4°F ~ 113°F / -20°C ~ 45°C (If storing 1 month)
  - 14°F ~ 95°F / -10°C ~ 35°C (If storing 6 months)
  - 65% ± 20% Relative Humidity (RH)
- If the battery's state of charge is below 30%, charge the battery to at least 50% before storing it for more than 24 hours.
- **CAUTION:** Never store your Anthem battery at a low state of charge (below 30% SOC). Leaving the battery at a low state of charge for a prolonged period could damage it and may not be covered under your warranty.
- If you ride in hot weather (>95°F / 35°C) or spend a majority of your ride at freeway speeds, the battery will benefit from not being charged while heat soaked. Allowing your battery a few hours to cool off prior to recharging will prolong its life. Charging while the battery is hot will also increase charge times.
- Once your Anthem has been charged, disconnect the charger to ensure the best long-term health of your battery.
- For long term storage (>30 days) of your Anthem, see "Parking and Long-Term Storage", on page 113.
- After long-term storage, charge the battery for a full cycle to restore any lost balance within the pack.
- Please note – it is normal that when unplugged and off, the Anthem's electronics will consume a small amount of power and the battery will drain slowly.



## Charging Components and Charge Time

---

The Anthem features a 3.3 kW on-board charger. It is compatible with either 110V or 220V. Using the included 110V cord (with NEMA 515R connector), your Anthem will charge from empty to 80% in about 2.3 hours and to 100% in 3.25 hours. Using the Ryvid J-Plug accessory, or optional 220V cord (with NEMA 1450R connector) charge time from empty to 80% is reduced to approximately 1.3 hours and to 100% in approximately 1.85 hours.

Please note that charging time is dependent on many factors including state of charge, battery temperature, battery age, battery condition, and more.

## Charging Instructions (Attached to Anthem)

The Anthem battery may be charged while mounted to the bike, or separately from the bike. To begin charging the battery on the bike, simply connect the charge cord to a power source. The charger will then engage, and the charger fan will operate. Note that the bike may be powered on or off to begin charging. If the bike is turned on and charging, park mode will be engaged, and the throttle will not be active. To check the State of Charge (SOC), turn the bike on. The charge level indicator will flash while charging and indicate the current charge voltage and percentage. When the charge cycle is completed, the fan will stop, and the dash will indicate a full (100%) SOC.

**CAUTION:** If the bike is being prepped for storage at the recommended 50% state of charge, simply unplug the charger when the dash indicates approximately 50% SOC.

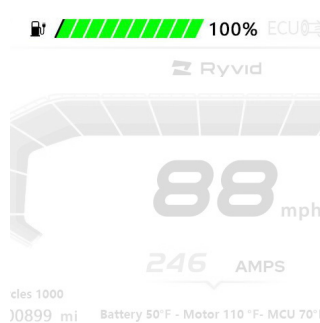
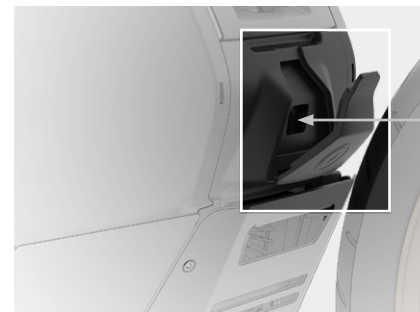
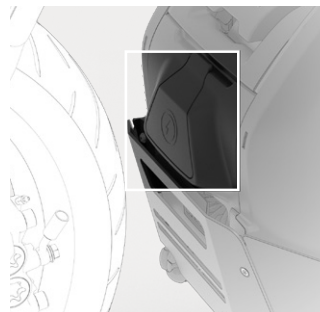



## Charging Instructions (Removed from Anthem)

When the battery is off the bike, raise the luggage handle to view the battery SOC indicator. Pressing the power button will activate red LED indicators corresponding to the battery's state of charge:

1 red light = 0-25%

2 red lights = 26-50%

3 red lights = 51-75%

4 red lights = 76-100%

When plugged in, the LED indicators will flash indicating charging in progress. When the battery is fully charged, all four LEDs will indicate solid red.

**CAUTION:** If the bike is being prepped for storage at the recommended 50% state of charge, simply unplug the charger when the dash indicates approximately 50% SOC.

**Please navigate to page 113 for long-term storage.**

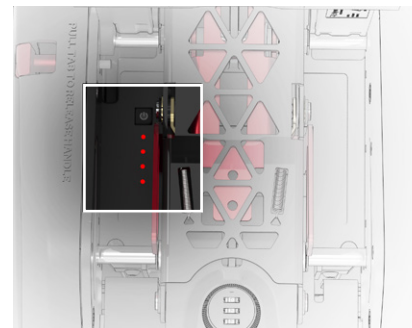
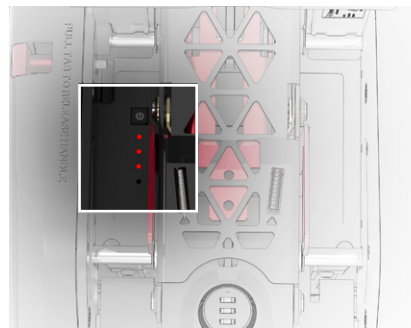
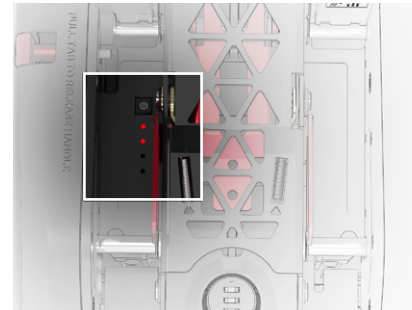
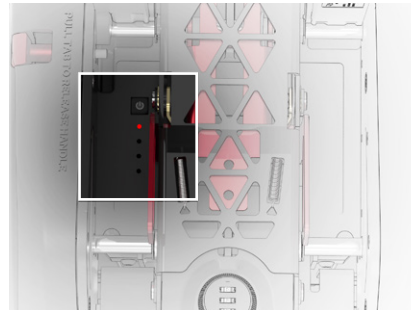



## Battery Life

---

Battery life is dependent on many factors, including charge cycles, high temperatures, storage conditions, cell design, and more. Ryvid has designed the Anthem battery to balance battery life, vehicle performance, and usability. Your specific use will impact the battery's life expectancy; however, under normal conditions the battery will maintain approximately 80% capacity for up to 1,500 cycles. This cycle count is tracked on the Anthem dash. For further details, please see your warranty documentation.

### Usage Tips

- If Anthem is used daily or as a commuter bike, please charge the battery after each trip, and unplug it whenever it is full. By minimizing the duration of time that the battery is fully charged or completely empty, battery life can be extended.
- Do not plug the charging cable to the battery for multiple days. Always unplug the charger when the battery is full, there is no advantage to leaving the battery on the charger.



## Battery Removal, Installation, and Handling

The Anthem features an easy-to-release battery which can be removed for charging or storage without the use of tools. The battery also features a secondary safety latch, a battery-presence safety switch, and a combination security lock.

### **WARNING:**

- The Anthem battery is heavy and should be handled with caution. When installing and removing the battery follow the instructions below to avoid potential injury or damage to the motorcycle.

### **BEFORE REMOVING OR INSTALLING THE BATTERY, ALWAYS VERIFY THAT:**

- The motorcycle is securely resting on the wheels and kickstand so that the bike does not tip over when the weight of the battery is removed or added.
- The motorcycle is positioned in a safe location, away from traffic or other hazards that may pose a threat to safety while conducting these tasks.

# Battery Lock

The battery is equipped with a combination lock to help prevent theft. A combination lock also has the added benefit of not requiring a physical key, which could be lost

## Setting the Battery Lock Combination Code

The combination from the factory will be set to "0-0-0". It's highly recommended that you reset this code when you take ownership of your Anthem.

### To reset the code, follow these steps:

1. Set the combination lock to the unlocked code (Note: code set to "0-0-0" from the factory)
2. Using a paperclip or similar thin pin, continually depress the code reset button while setting the new code. The reset button is located on the forward-facing side combination lock.
3. When the desired code is set, release the code reset button. Your code is now set!

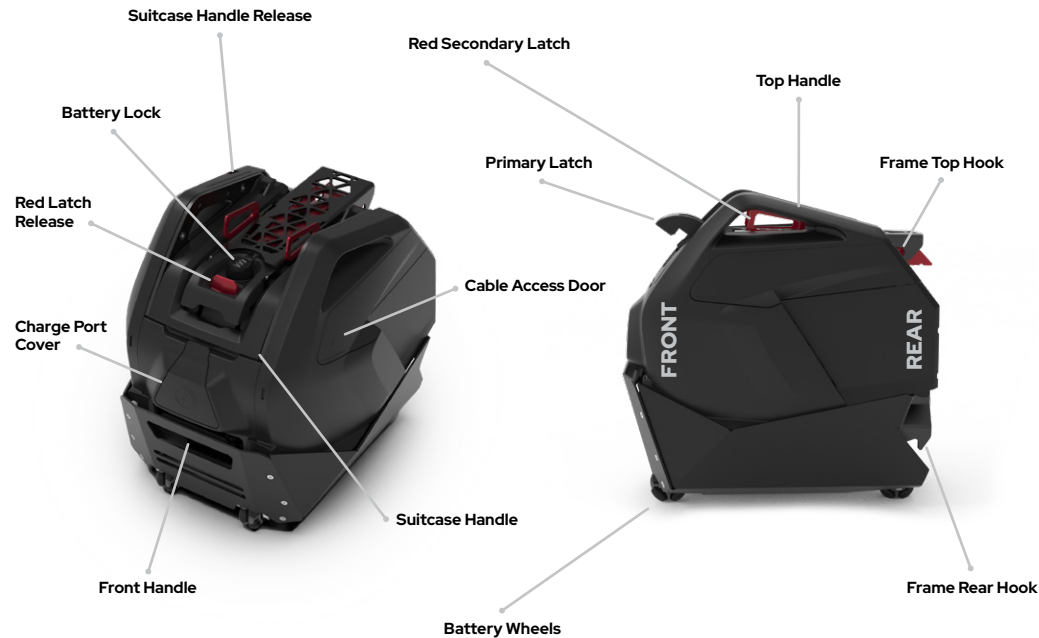

# Resetting The Battery

To perform a battery reset:

1. Remove the battery from your Anthem. **(refer to page 69 for the battery removal process)**
2. Pull the red release tab and lift up the transport handle.
3. Locate the battery power button on the top of the battery, beneath the transport handle.
4. Press and hold the battery power button for 45 seconds.
5. The battery indicator LEDs will flash green when released, the battery resets.
6. Reinstall the battery in the Anthem, you should be ready to ride.

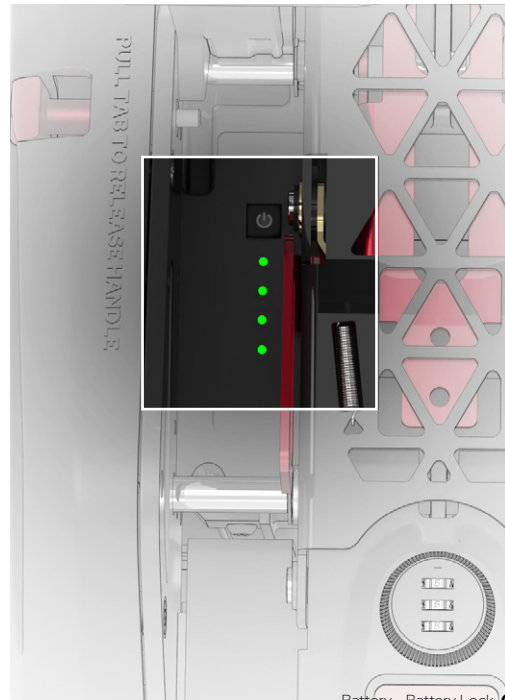
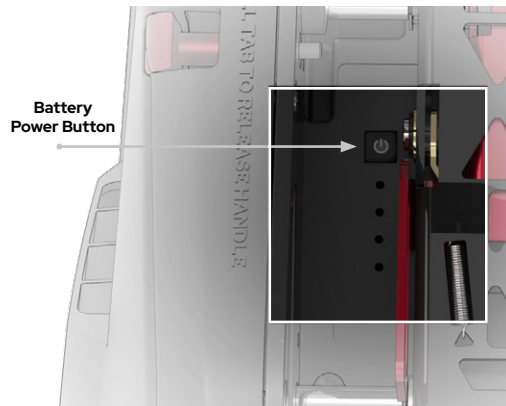



## Removing the Battery from the Bike:

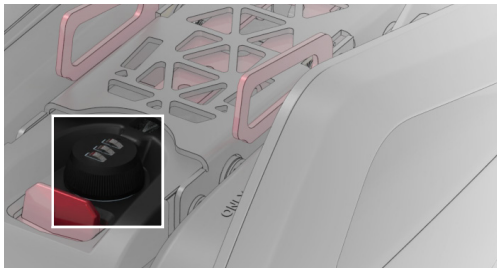

- 1.** Set the combination lock to the unlocked code and rotate the lock 90 degrees counterclockwise.

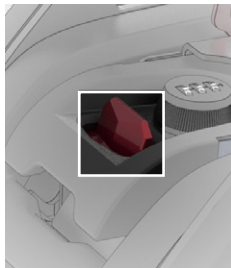

- 2a. Primary Latch:** Pull the red latch release trigger forward.

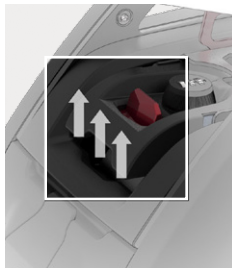

- 2b. Primary Latch:** Lift the primary latch handle upwards. The battery is now resting on the secondary latch.

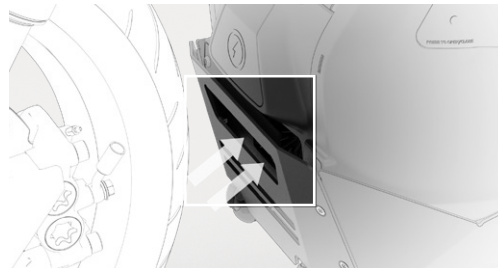

- 3a.** Use one hand to support the battery from the front handle (located just below the charge port).

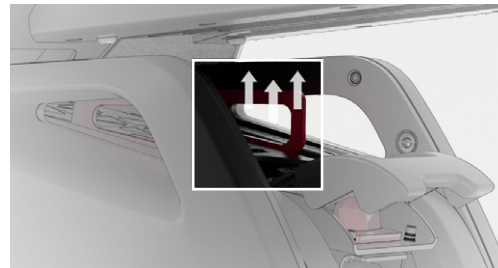

- 3b. Secondary Latch:** Reach your other hand through the battery side handle with palm facing upwards. Lift the red secondary latch handle upwards, releasing the secondary latch. The weight of the battery will partially transition to the hand supporting the front handle.

## Removing the Battery from the Bike:



4. Slowly lower the front of the battery to the ground.

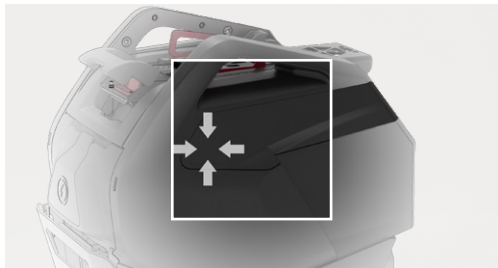

5. Open the cable access door on the left side of the battery by pushing on the forward edge of the door. Then swing the door open.



6. **Disconnect Cables:** Disconnect the power, ground, and data cables. Note that the positive and negative battery cables (colored orange) have a button at the end that must be pressed to release from the battery.

**The data cable (colored black) stays attached to the battery.**

**Disconnect the data cable at the connector that is inline with the black cable.** Pull down red tab to unlock, then push in black center piece and gently pull the connector apart.

**DISCONNECT DATA CABLE FROM IN-LINE PLUG:**



## Removing the Battery from the Bike:

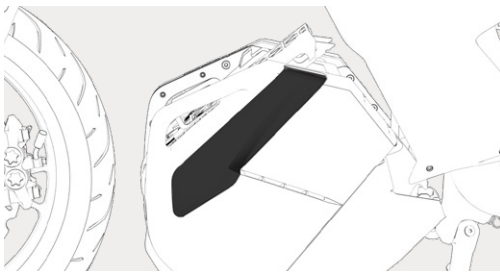

**7.** Close the cable access door. Please do not lose the cable access door.

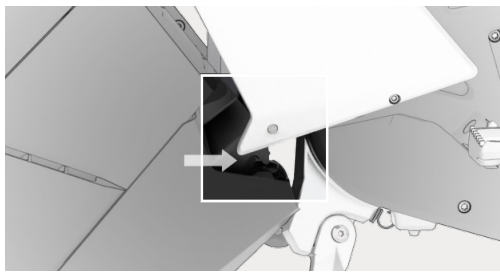

**8.** With the front wheels of the battery on the ground, carefully tilt the battery forward to unhook the battery's lower rear hooks from the lower frame pin.

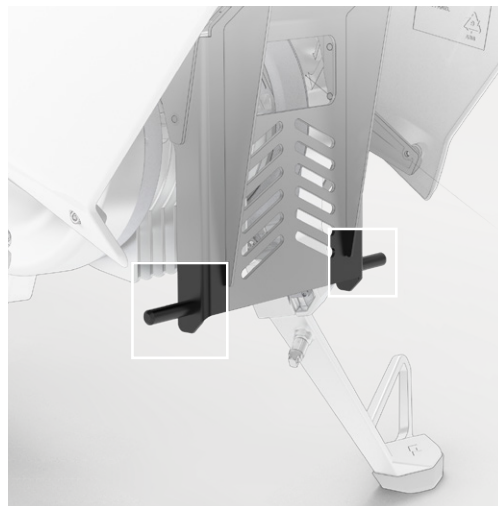

Detail view of the lower frame pins.

**Page 81 for moving the battery when off of the Ryvid Anthem.**

**Page 113 for storage of the battery.**

## Installing the Battery on the Bike:

---

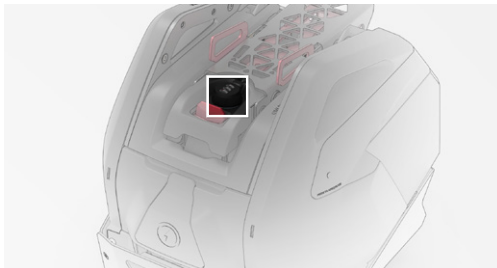

1. Ensure that the combination lock is unlocked and rotated 90 degrees counterclockwise.

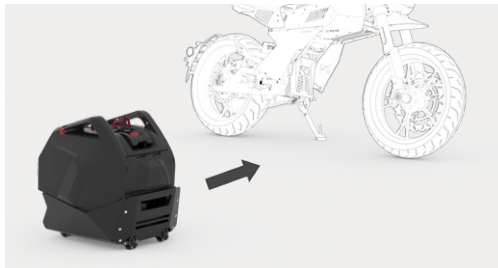

2. Position the battery underneath the motorcycle. The omnidirectional wheels at the front of the battery will help make alignment easier.

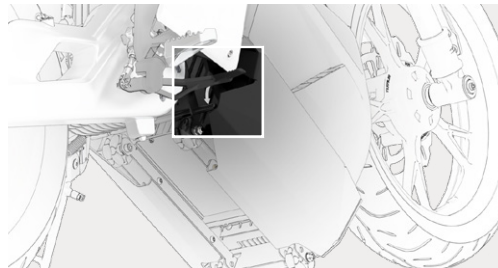

3. With hands securely on the forward handle and side handles, tilt the battery forward and position the battery's lower rear hooks on the lower frame pins.

## Installing the Battery on the Bike:

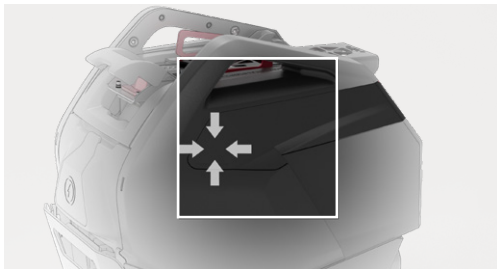

- 4.** Open the cable access door on the left side of the battery by pushing on the forward edge of the door. Then swing the door open.



- 5a. Connect the Battery Cables:** Connect the discharge cables first. The positive and negative battery cables (colored orange) can be pushed on to their connectors. The negative cable has a black cap to match the black connector on the battery. The positive cable has an orange cap to match the orange connector on the battery.

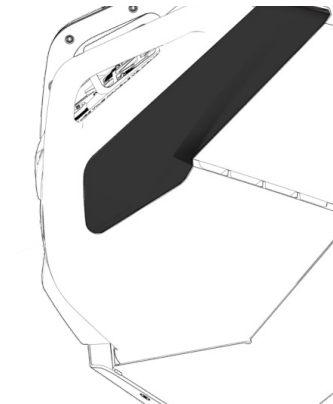

- 5b. Connect the Data Cable:** Reconnect the black data cable with the in-line connector. Lock it into place by pushing the red tab up once connected.

**Take care to observe the correct polarity and orientation of the battery connectors.**

- 6.** Close the access door.



## Installing the Battery on the Bike:

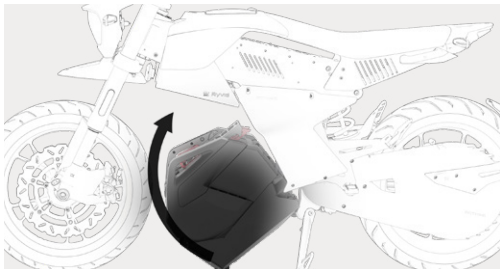

**7.** Lift the front of the battery up, rotating it around the lower frame pin, until the secondary latch engages with the upper frame pin. The motorcycle should now be supporting the full weight of the battery.



**8a. Primary Latch:** Lift the primary latch handle upwards to allow the latch to engage the upper frame pin.

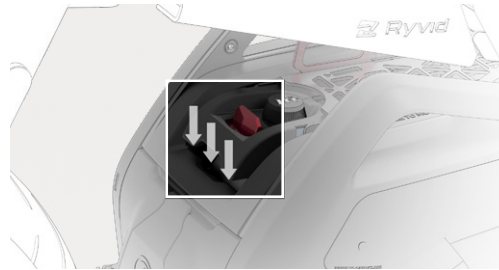

**8b. Primary Latch:** Close the primary latch handle by pushing it downward until flush with the battery.

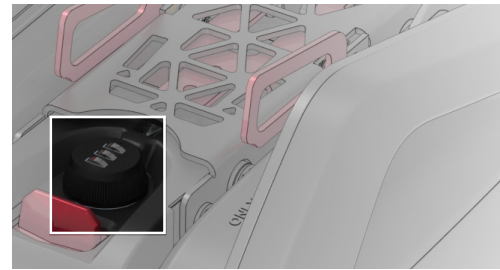

**9.** Rotate the combination lock 90 degrees clockwise and scramble the code to lock its position.

**The battery is now installed, and ready to use.**

## Moving the Battery When Off the Bike:

Due to the weight of the battery, it is ideal to move the battery on the ground and avoid lifting it when possible. The battery attachment to the bike was designed in a way such that the full weight of the battery does not need to be lifted to remove it from or attach it to the bike. Additionally, the battery has wheels underneath it and an extendable “luggage” handle that allows the battery to be wheeled around without needing to bend over.

**CAUTION:** The extendable luggage handle is good for moving the battery on the ground but is not suitable for lifting. If the battery needs to be lifted off the ground, use the battery side handles instead of the luggage handle.

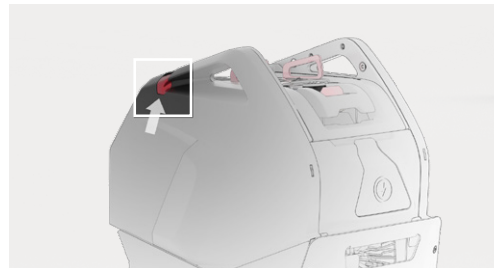

### 1. To extend the battery luggage handle:

With the battery removed from the bike, locate the red handle release trigger on the rear, left side of the battery.

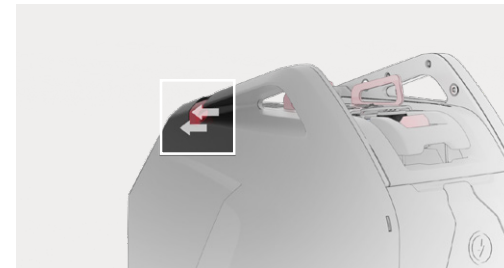

### 2. To extend the battery luggage handle:

Pull the red handle release trigger and the battery handle will spring forward.

## Moving the Battery When Off the Bike:

---



### 3. To extend the battery luggage handle:

Rotate the battery handle until you hear a click, at which point the handle is locked in place.



### 1. To stow the battery luggage handle:

Pull the red handle release trigger and rotate the battery handle forward.



### 2. To stow the battery luggage handle:

With the battery handle in the down position, you will notice the handle sits proud of the forward face of the battery. Push the battery handle towards the back of the battery until you hear a click, indicating that the battery handle is locked in the stowed position.



## Adjustable Seat

---

The Anthem is equipped with an electronically adjustable seat to accommodate riders of various heights. Seat height ranges from 30 in (76.2 cm) to 34 in (86.4 cm) from the ground. Although the seat height is adjustable while riding, Ryvid recommends that the seat height is adjusted while stationary.

The seat height is controlled on the right handlebar control with a 3-position toggle switch that moves left to right. The left position will lower the seat to the bottom of its travel, the right switch position will raise the seat to the top of its travel, and the center switch position will stop the seat movement at any point in its travel.

Note: The seat actuator will stop automatically when it reaches the top or bottom of its travel even if the switch is positioned to command up or down movement. Therefore, there is no need to reposition the switch to the center to avoid excessive wear of the system.

# Suspension Settings

---

The Anthem is equipped with suspension components that can be adjusted to suit the rider's comfort preferences. These settings are set from the factory based on the input provided by the customer at the time of sale.

The front suspension permits adjustment of dampening in compression. The rear suspension permits adjustment of dampening in compression and rebound. The term dampening refers to the control and regulation of the suspension's movement, providing resistance to compression or rebound forces. Harder settings are generally preferable for higher loads and/or more responsive handling. Softer settings are generally preferable for lighter loads and/or comfort over rougher terrain.

## Front Suspension

The front suspension dampening is adjustable at the top of each fork cap using a flat head screwdriver. There are a total of 30 clicks of dampening adjustment. Rotating clockwise will make dampening harder and rotating counterclockwise will make dampening softer. When adjusting settings, start by adjusting 1 click at a time on each fork.

**WARNING:** The left and right settings should always be adjusted simultaneously to maintain symmetrical dampening settings.

## Rear Suspension

The rear suspension dampening is adjustable at the rear shock near the lower shock mount. There are a total of 15 clicks of dampening adjustment, which can be made using a flat head screwdriver. Rotating clockwise will make dampening harder and rotating counterclockwise will make dampening softer. When adjusting settings, start by adjusting 1 click at a time.

## Suspension Log

It is recommended that you keep a written log of the adjustments you make so you can optimize for your specific loading conditions and riding preferences.



# Pre-Ride Checks

Check the following items each time before riding your motorcycle. Do not ride your motorcycle unless all conditions below are satisfied. In the event that an item does not pass the check, contact Ryvid Service or a professional motorcycle technician.

S/N	Item	Checks
1	Battery	Ensure battery has sufficient charge.
2	Brakes	Check the following in the braking system: <ol style="list-style-type: none"><li>1. Brake fluid is above the minimum fill level.</li><li>2. Check the brake handle has minimum of 2-3mm (~1/16 in.) free travel.</li><li>3. Check wear on the brake pads and rotors.</li></ol>
3	Throttle	With the vehicle off, gently turn the throttle to full engagement. Then, release the throttle completely. The throttle should return to the neutral/closed position.
4	Steering	Ensure the action is smooth, but not loose, from lock to lock. Also ensure there is no binding of the control cables.

5	Tires	Check tire pressure and wear. See the VIN label for recommended tire pressures. (refer to page 17 for VIN label location)
6	Headlights, Turn Signals, and Brake Lights	Ensure headlights, turn signals, and brake lights are functioning properly.
7	Kickstand	Ensure the kickstand and integrated motor disconnect switch are functional by verifying that when the kickstand indicator is displayed in the upper right corner of the display.  Ensure the kickstand returns to and stays at the fully up position by spring tension.
8	Critical Bolts	Check that the front wheel bolts, rear wheel bolts, and swing arm bolt are secure.



# Carrying Capacity, Loading, and Vehicle Range

## General

**WARNING:** Overloading or improper loading can cause a crash in which you could be seriously hurt or killed. Observe all load limits and loading guidelines in this manual.

Your Anthem has been designed to carry the rider, one additional passenger, and limited cargo. When you carry cargo, you may feel some difference during acceleration and braking, but if you keep your motorcycle well-maintained, with good tires and brakes, you can safely carry loads within the limits and guidelines outlined below.

How much weight you put on your Anthem, and how you load it, are important for your safety. Please take care to observe the loading guidelines below.

**CHECK MANUFACTURING LABEL**

MANUFACTURED BY: RYVID INC.		AUGUST 2023	ANTHEM
<b>GVWR</b>	292 KG (643 LB)		
<b>GAWR FRONT</b>	125 KG (275 LB)	WITH M120/70R17 TIRE, 17xMT4.00 RIM AT 241KPA 35PSI COLD	
<b>GAWR REAR</b>	167 KG (368 LB)	WITH M160/60R17 TIRE, 17xMT4.50 RIM AT 241KPA 35PSI COLD	
THIS VEHICLE CONFORMS TO ALL APPLICABLE US FEDERAL MOTOR VEHICLE SAFETY STANDARDS IN EFFECT ON THE DATE OF MANUFACTURE SHOWN ABOVE			
<b>VIN:</b>	0000000000000000	<b>TYPE:</b>	MOTORCYCLE

# Loading Guidelines

---

Light weight or small items may be secured to the seat. Additional items should be kept in a backpack or other container which is secured to the rider without impairing the ability to operate the motorcycle.

Improperly loading your Anthem can affect its stability and handling. Even if your motorcycle is properly loaded, you should ride at reduced speeds while carrying cargo and plan for increased braking distances. Follow these guidelines whenever you carry cargo:

- Never exceed 400 lbs. (181.4 kg) maximum load. The term load is defined as any weight added to the Anthem above its stock configuration. This includes the weight of the rider, passenger, cargo, accessories, and modifications to the Anthem.
- If riding with two passengers (or loaded more than 200 lbs) over rough terrain, move the seat to the middle position or higher to avoid possible interference between rear wheel and bottom of the seat when the shock is fully compressed.
- Tire inflation: Check that both tires are properly inflated to the pressure specified on the VIN label (refer to page 19 for VIN label location).
- Weight distribution: Weight location should be centered between the wheels and as low as practical to avoid tipping and to maintain a low center of gravity.
- Regular checks: Check your load regularly during your trip to ensure nothing has shifted.

- Consider aerodynamics: Large, bulky items can catch the wind and make your bike more difficult to handle, especially at high speeds.
- Securely attach cargo: To prevent loose items from creating a hazard, make sure that all cargo is tied down securely.

# Vehicle Range

---

The distance an electric vehicle can travel on a single full charge of its battery is referred to as its range. It is important to remember that range can vary significantly depending on your driving habits. The more efficiently you drive, the better range you can expect from your electric vehicle. Factors that can impact range include vehicle load, speed, acceleration, tire pressure, number of stops and starts, weather conditions, and changes in elevation. Combined, these factors make up your trip profile.

To get the most out of your vehicle, it is recommended to drive conservatively when first getting to know your electric vehicle and your typical commute. Once you become familiar with the range and performance, you can adjust your driving style to maximize the performance of the Anthem for a given trip profile.



## Maintaining Your Anthem

---

Use the charts below to keep track of your Anthem's service needs. If you have questions about any maintenance procedures, please contact Ryvid Service.

Always operate within your personal technical abilities or seek assistance from a professional motorcycle technician.

## Periodic Maintenance Intervals

---

When driving in dusty, dirty, or harsh conditions, maintenance should be performed more frequently.

Item	Routine	Every Ride	Every 500 miles or 1 month	3,000 miles or 12 months	6,000 miles or 18 months	10,000 miles or 24 months
Belt Tension	Verify belt tension using the tensioner tool	—	—	—	—	
Brake Fluid	Check level using sight glass on handlebars, add more fluid if below minimum level		—	—	—	—
Brake Fluid	Replace brake fluid	—	—		—	
Brake Rotors	Inspect for visual damage or excessive wear		—	—	—	—
Brake Rotors	Measure and ensure at least 3.5mm of thickness	—	—		—	
Brake Pads	Inspect for damage and excessive wear		—	—	—	—

 : Indicates Visual Inspection

 : Indicates Service

Item	Routine	Every Ride	Every 500 miles or 1 month	3,000 miles or 12 months	6,000 miles or 18 months	10,000 miles or 24 months
Brake Pads	Measure and ensure at least 3mm (0.1in) of friction material is remaining	—	—		—	
Brake Lever	Ensure minimal free play		—	—	—	—
Turn Signals	Ensure function in both directions		—	—	—	—
Headlight	Check both high and low beam function		—	—	—	—
Shock Absorbers	Check operation and for oil leakage		—	—	—	—
Fasteners	Ensure all fasteners are tightened	—		—	—	—



Item	Routine	Every Ride	Every 500 miles or 1 month	3,000 miles or 12 months	6,000 miles or 18 months	10,000 miles or 24 months
Wheels	Check for damage	—	👁️	—	—	—
Tires	Check tread depth, if below 2mm; replace tire. Ensure filled to correct PSI	👁️	—	—	🔧	—
Steering Mechanism	Ensure smooth operation along full range of motion. Ensure steering nut is tight	👁️	—	—	—	—
Front & Rear Wheel Bearings	Ensure smooth rotation and that no oil is leaking	—	👁️	—	👁️	—
Kickstand	Ensure kickstand moves fully without sticking and is retained by spring	👁️	—	—	—	—
Drive Motor	Ensure smooth operation	—	—	—	—	👁️

# Wheels and Tires

## Inspect both wheels for the following:

- Bends or cracks.
- Impact marks.

## Inspect both tires for the following:

- Cuts, cracks, splits, or missing tread lugs in the tread or sidewall area.
- Bumps or bulges within the tire body.
- Uneven tire tread wear. Wear on one side of the tire tread or flat spots in the tire tread indicate a problem with the tire or Motorcycle.
- Exposed tire thread or cords.
- Tread depth below 1/16 in (1.6 mm).

**IF EITHER OF THE WHEELS OR TIRES ARE FOUND TO HAVE ANY OF THE ABOVE CONDITIONS, REPLACE THE WHEEL OR TIRE IMMEDIATELY.**

# Tire Inflation



**CHECK MANUFACTURING LABEL**

**WARNING:** Improper inflation is a common cause of tire failure and may result in severe tire cracking, tread separation, bead unseating from wheel, “blowout,” or unexpected loss of motorcycle control, causing serious injury or death.

Tire pressure should be checked and adjusted to the proper inflation as noted on the FMVSS label on the Anthem before each ride. Tire pressure should be checked using an accurate gauge when the tires are COLD.

Note: A COLD tire is defined as one that has not been ridden on for at least 3 hours.

Note: Always install the valve stem caps after adjusting the tire pressures.

# Tire Replacement

The tires that are equipped with the Anthem were specified to provide the best overall riding experience. Tire specifications approved by Ryvid can be located on the FMVSS label for your Anthem (refer to FMVSS label below).

**WARNING:** Tires other than those originally equipped on the Anthem may cause adverse handling and performance characteristics.

FMVSS Label:

<b>MANUFACTURED BY: RYVID INC.</b>	<b>AUGUST 2023</b>	<b>ANTHEM</b>
<b>GVWR</b> 292 KG (643 LB)		
<b>GAWR FRONT</b> 125 KG (275 LB)	WITH M120/70R17 TIRE, 17xMT4.00 RIM AT 241KPA 35PSI COLD	
<b>GAWR REAR</b> 167 KG (368 LB)	WITH M160/60R17 TIRE, 17xMT4.50 RIM AT 241KPA 35PSI COLD	
THIS VEHICLE CONFORMS TO ALL APPLICABLE US FEDERAL MOTOR VEHICLE SAFETY STANDARDS IN EFFECT ON THE DATE OF MANUFACTURE SHOWN ABOVE		
<b>VIN: 0000000000000000</b>	<b>TYPE: MOTORCYCLE</b>	



## Brakes

---

The fluid level in the reservoirs may drop slightly during normal use as a result of brake pad wear but should not be allowed to drop below the MIN mark. It may be necessary to top off the reservoir to the max mark during the 12-month service interval. This is normal.



**WARNING:** Brake fluid is highly toxic. Keep containers sealed and out of the reach of children. If accidental consumption of fluid is suspected, seek medical attention immediately.

**WARNING:** If the fluid comes into contact with the skin or eyes, rinse immediately with plenty of water and seek medical attention immediately.

**WARNING:** Do not ride the motorcycle if the brake fluid is below the MIN mark on either reservoir. Brake fluid **MUST** be added to the reservoir before riding.

**WARNING:** If the brake lever or brake pedal travel is unusually long, the feel is spongy or if there is any significant loss of brake fluid, do not continue riding and have the problem repaired prior to return to service.

## Brake Fluid Replacement

---

Brake fluid must be replaced every 12 months regardless of the distance the motorcycle has been ridden. Use only DOT 4 brake fluid. It is recommended that this procedure is carried out by a professional motorcycle technician.

**CAUTION:** Failure to service brakes per the recommended interval could result in extended stopping distances or complete brake failure.

**CAUTION:** Only use new fluid from an airtight container. Fluid from open containers or fluid previously bled from the system will have absorbed moisture, which will adversely affect performance, and must not be used.

**CAUTION:** Brake fluid will damage plastic or painted surfaces. Soak up any spillage with an absorbent cloth immediately and wash the area with a mixture of car soap and water.

# Cleaning Your Anthem

---

To prolong the life of your motorcycle, wash it periodically, as doing so helps ensure that safety-related parts remain in full working order. If tar, bugs, or other similar deposits have accumulated, clean them off as soon as possible.

## Recommended Cleaning Process

1. Gently wash your motorcycle with a sponge or a clean, soft cloth, mild detergent, and plenty of non-pressurized water.
2. Use care when cleaning the plastic parts (dash, fenders, and side panels), which can scratch more easily than the other parts of your motorcycle.
3. For a more thorough clean, release the battery latch and lower the front of the battery to the ground while leaving the cables connected. This will allow cleaning behind the battery and also permit any accumulated water to drain out from the battery case.
4. After washing, rinse your motorcycle thoroughly with plenty of clean water to remove any detergent residue.
5. Dry your motorcycle with a chamois or a soft, dry towel.
6. After cleaning, inspect for damage, wear, or leaks.

After washing the motorcycle, allow all electrical components to dry before operation. If the motorcycle is ridden after being washed, use caution, and allow extra distance when braking initially, as moisture could remain on the brake pads.

**CAUTION:** Improper cleaning can damage electrical components, cowlings, panels, and other plastic parts. Do not use steam or high-pressure water cleaner systems; they can cause water intrusion of bearing, seals, and electrical components. Avoid spraying water of great force around the dash unit, charge port, battery, and controller.

**CAUTION:** Do not use any harsh chemical products on plastic parts. Be sure to avoid using cloths or sponges which have been in contact with strong abrasive cleaning products, solvent or thinner, fuel (gasoline), rust removers or inhibitors, brake fluid, antifreeze, or electrolyte.

**WARNING:** After cleaning and before starting your journey, always test the brakes.

## Wheels and tires

Avoid using strong acidic wheel cleaners. If such products are used on hard-to-remove dirt, do not leave the cleaner on the affected area any longer than instructed. Also thoroughly rinse the area off with water, immediately dry it, and then apply a corrosion protection spray.

**WARNING:** Do not use products such as tire dressings on tires as this will adversely affect traction.

# Tie Down Instructions

## Items Needed

- Ramp
- Step Stool (optional depending on trailer height and ramp width)
- 4 quality motorcycle tie-down straps
- 4 soft loops
- Trailer or truck bed with 4 floor mounted tie-down points
- Wheel chock or fixed surface to park front wheel against
- Friend / spotter

Lower Triple Clamp  
Tie Down Location

Lower Seat Actuator  
Tie Down Location

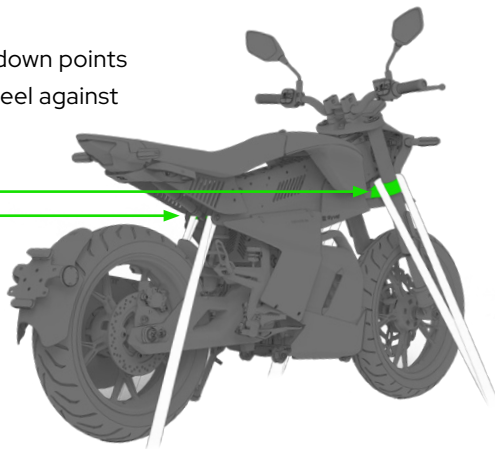

## Tie Down Process

1. Position the ramp and secure it with a tie down strap to prevent it from sliding out of position during the loading process.
2. With the help of a friend/spotter, push your Anthem into position on the trailer or truck bed securing the front wheel against a wheel chock or against the wall of the trailer or truck bed.  
**WARNING:** Do not attempt to ride your Anthem onto the ramp or walk next to the bike while feathering the throttle as serious injury may occur.
3. Attach soft loops at the front of the motorcycle above the lower triple clamp, and at the rear of the motorcycle at the lower seat actuator mount.  
**CAUTION:** Do not use the passenger hand holds as rear tie down points as this can cause damage to the seat actuator.
4. Cinch down the front and rear of the bike. The straps should be tight enough to securely hold the bike in place but not so tight as to fully compress/bottom out the suspension.  
**CAUTION:** Do not leave your Anthem tied down for extended periods of time as this may cause damage to the suspension components.





## Parking and Long-Term Storage

- Whenever you plan on not riding or storing your motorcycle for extended periods of time (more than 30 days), it is recommended that you first fully discharge the battery to 0%, or as close as possible. Then charge the battery until SOC is at 50%. This can be monitored from the Anthem display or by short pressing the power button on top of the battery (if removed from the motorcycle) and observe that 2 LED lights are shown solid (this means battery is about 50%). Lastly, charge the battery to approximately 60% state of charge (SOC) and then leave the charger disconnected.
- The battery will discharge extremely slowly over time. Check the SOC at least monthly and charge it back up to 60% if it has dropped below 30%.
- To prolong the life of your battery, store your motorcycle in a cool area, as storing it in a hot area will shorten the battery life. The recommended storage temperature is +32°F (0°C) to 85°F (29°C).
- **CAUTION:** Only charge the battery using provided Ryvid charger and cables.



## Customer Assistance

---

Please have the following available when contacting Ryvid, as this information is essential to answer your questions effectively and efficiently or resolve your concerns.

- Owner's name and address
- Owner's telephone number
- Vehicle identification number (VIN)
- Date of purchase
- Motor serial number

Ryvid Inc. can be contacted as follows:

12090 CARSON ST STE H-504  
HAWAIIAN GARDENS, CA 90716  
Phone: +1 (562) 573-1862  
Monday-Friday 8am to 6pm (Pacific Time)

E-Mail: [support@ryvid.com](mailto:support@ryvid.com)  
[www.ryvid.com](http://www.ryvid.com)

## Reporting Safety Defects

---

### United States:

If you believe that your vehicle has a defect which could cause a crash or could cause injury or death, you should immediately inform the National Highway Traffic Safety Administration (NHTSA) in addition to notifying Ryvid Inc.

If NHTSA receives similar complaints, it may open an investigation, and if it finds that a safety defect exists in a group of vehicles, it may order a recall and remedy campaign. However, NHTSA cannot become involved in individual problems between you and Ryvid Inc.

To contact NHTSA, you may call the Vehicle Safety Hotline toll-free at: 1-888-327-4236 (TTY: 1-800-424-9153); go to <http://www.safercar.gov>; or write to:

Administrator  
National Highway Traffic Safety  
1200 New Jersey Avenue SE  
Washington, DC 20590

You can also obtain other information about motor vehicle safety from: <http://www.safercar.gov>

## Video Links

---



**We encourage you to visit our website for service video instructions:**

<https://ryvid.com/pages/support-service>



 **Ryvid**

**ANTHEM**