

ROTAX

OPERATORS MANUAL

FOR ROTAX ENGINE TYPE 912 SERIES

REF NO.: OM-912 | PART NO.: 899700



 **WARNING**

Before starting the engine, read the Operators Manual, as it contains important safety relevant information. Failure to do so may result in personal injuries including death. Consult the original equipment manufacturers handbook for additional instructions!

These technical data and the information embodied therein are the property of BRP-Rotax GmbH & CO KG, Austria, acc, BGBl 1984 no. 448, and shall not, without prior written permission of BRP-Rotax GmbH & Co KG, be disclosed in whole or in part to third parties. This legend shall be included on any reproduction of these data, in whole or in part. The Manual must remain with the engine/aircraft in case of sale.

ROTAX[®] is a trade mark of BRP-Rotax GmbH & Co KG. In the following document the short form of BRP-Rotax GmbH & Co KG = BRP-Rotax is used. Other product names in this documentation are used purely for ease of identification and may be trademarks of the respective company or owner.

Copyright 2016 © - all rights reserved.

Translation into other languages might be performed in the course of language localization but does not lie within ROTAX's scope of responsibility. In any case the original text in English language and the metric units are authoritative.

Table of Content

Chapter	INTRO – Introduction
Chapter	LEP – LIST OF EFFECTIVE PAGES
Chapter	TOA – Table of amendments
Chapter	1 – General note
Chapter	2 – Operating instructions
Chapter	3 – Standard operation
Chapter	4 – Abnormal operation
Chapter	5 – Performance and Fuel consumption
Chapter	6 – Weights
Chapter	7 – System Description
Chapter	8 – Preservation and storage
Chapter	9 – Supplement

NOTES

INTRO) Introduction

Topics in this chapter

The structure of the Manual follows whenever it is possible the structure of the „GAMA Specification #1 for Pilot's Operating Handbook“.

Foreword

BRP-Rotax GmbH & Co KG (hereinafter “BRP-Rotax”) provides “Instructions of Continued Airworthiness”, which are based on the design, the tests and certification of the engine and its components.

These instructions apply only to engines and components supplied by BRP-Rotax. This Operator Manual contains important information about safe operation of the engine, together with descriptions of the systems and its layout, technical data, operating media and the operational limits of the engine.

The specified data apply only to the engine and not to specific applications in particular aircraft. The aircraft manufacturers Operators Manual is therefore definitive in terms of the operation of the engine, as it contains all of the aircraft-specific instructions.

NOTES

LEP) LIST OF EFFECTIVE PAGES

Chapter	Page	Date	Chapter	Page	Date
	cover page			3	Nov. 01 2016
INTRO	1	Nov. 01 2016		4	Nov. 01 2016
	2	Nov. 01 2016		5	Nov. 01 2016
LEP	1	Nov. 01 2016		6	Nov. 01 2016
	2	Nov. 01 2016		7	Nov. 01 2016
TOA	1	Nov. 01 2016		8	Nov. 01 2016
	2	Nov. 01 2016		9	Nov. 01 2016
1	1	Nov. 01 2016	3	10	Nov. 01 2016
	2	Nov. 01 2016		11	Nov. 01 2016
	3	Nov. 01 2016		12	Nov. 01 2016
	4	Nov. 01 2016		1	Nov. 01 2016
	5	Nov. 01 2016		2	Nov. 01 2016
	6	Nov. 01 2016		3	Nov. 01 2016
	7	Nov. 01 2016		4	Nov. 01 2016
	8	Nov. 01 2016		5	Nov. 01 2016
	9	Nov. 01 2016		6	Nov. 01 2016
	10	Nov. 01 2016		7	Nov. 01 2016
	11	Nov. 01 2016		8	Nov. 01 2016
	12	Nov. 01 2016		9	Nov. 01 2016
	13	Nov. 01 2016	10	Nov. 01 2016	
	14	Nov. 01 2016	11	Nov. 01 2016	
	15	Nov. 01 2016	12	Nov. 01 2016	
	16	Nov. 01 2016	4	1	Nov. 01 2016
	17	Nov. 01 2016		2	Nov. 01 2016
	18	Nov. 01 2016		3	Nov. 01 2016
	19	Nov. 01 2016		4	Nov. 01 2016
	20	Nov. 01 2016		5	Nov. 01 2016
2	1	Nov. 01 2016		6	Nov. 01 2016
	2	Nov. 01 2016		7	Nov. 01 2016
				8	Nov. 01 2016

Chapter	Page	Date	Chapter	Page	Date
5	1	Nov. 01 2016	8	4	Nov. 01 2016
	2	Nov. 01 2016		5	Nov. 01 2016
	3	Nov. 01 2016		6	Nov. 01 2016
	4	Nov. 01 2016		7	Nov. 01 2016
	5	Nov. 01 2016		8	Nov. 01 2016
	6	Nov. 01 2016		1	Nov. 01 2016
	7	Nov. 01 2016		2	Nov. 01 2016
	8	Nov. 01 2016		3	Nov. 01 2016
6	1	Nov. 01 2016	9	4	Nov. 01 2016
	2	Nov. 01 2016		1	Nov. 01 2016
7	1	Nov. 01 2016	9	2	Nov. 01 2016
	2	Nov. 01 2016		rear	
	3	Nov. 01 2016		page	

TOA) Table of amendments

Approval*

The technical content of this document is approved under the authority of
DOA ref. EASA.21J.048.

current no.	chapter	page	date of change	remark for approval	date of approval from authorities	date of inclusion	signature
0	INTRO	all	Nov. 01 2016	DOA*			
0	LEP	all	Nov. 01 2016	DOA*			
0	TOA	all	Nov. 01 2016	DOA*			
0	1 up to 9	all	Nov. 01 2016	DOA*			

Summary of amendments

Summary of the relevant amendments in this context, but without any claim to completeness.

current no.	chapter	page	date of change	comments
0	1 up to 9	all	Nov. 01 2016	new layout and change of company name

1) General note

Topics in this chapter

1.1 General	2
1.2 Abbreviations and terms	3
1.3 Safety	7
1.4 Safety information	9
1.5 Technical documentation	12
1.6 Standard version	14
1.6.1 Auxiliary equipment (optional).....	14
1.7 Type description	16
1.8 Engine components, engine views, cylinder designation	17
1.9 Technical data	18
1.10 Fuel consumption	18
1.11 Direction of rotation	19

Foreword

Before operating the engine, carefully read this Operators Manual. The Manual provides you with basic information on the safe operation of the engine.

If any passages of the Manual are not clearly understood or in case of any questions, please contact an ROTAX® authorized aircraft engines distributors or their independent service center. BRP-Rotax wishes you much pleasure and satisfaction flying your aircraft powered by this ROTAX®-aircraft engine.

1.1) General

Purpose

The purpose of this Operators Manual is to familiarize the owner/user of this aircraft engine with basic operating instructions and safety information.

Documentation

For more detailed information related to aircraft and aircraft/engine installation, maintenance, safety- or flight operation, consult the documentation provided by the aircraft manufacturer and/or its dealer.

For additional information on engines, maintenance or parts, you can also contact your nearest ROTAX® authorized aircraft engines distributor or their independent service center.

Engine serial number

When making inquiries or ordering parts, always indicate the engine serial number, as the manufacturer might make modifications to the engine in the course of product improvement. The engine serial number is located on the top of the crankcase, magneto side.

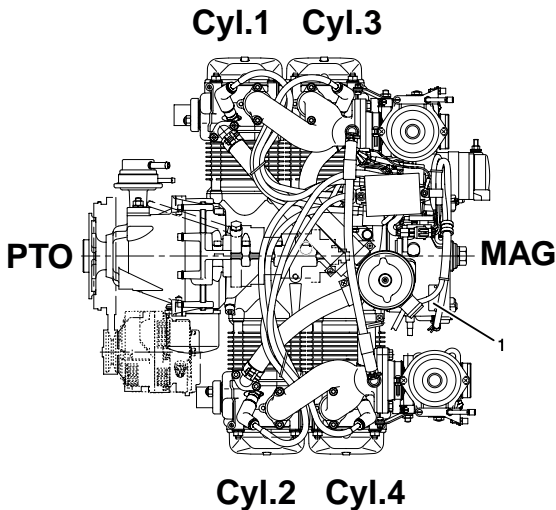



Figure .1: Pos. 1: Engine serial number

1.2) Abbreviations and terms

Abbreviations	Description
*	Reference to another section
	center of gravity
	The drop symbol indicates use of sealing agents, adhesives or lubricants (only in the Illustrated Parts Catalog).
°C	Degrees Celsius (Centigrade)
°F	Degrees Fahrenheit
rpm	Revolutions per minute
A	Ampere
AAPTS	Ambient Air Pressure Temperature Sensor
AC	alternating current
Ah	Ampere hour
A/C	Aircraft
AR	as required (IPC only)
assy.	assembly
ASB	Alert Service Bulletin
ACG	Austro Control GmbH
ACL	Anti Collision Light
API	American Petrol Institute
ASTM	American Society for Testing and Materials
ATA	Air Transport Association
AWG	American Wire Gauge
CAN	Control Area Network
Coil 1–4	Ignition coils 1–4
CPS 1+2	Crankshaft Position Sensor 1+2
CSA	Constant Speed Actuator
CTS	Cooling Temperature Sensor
CW	clockwise
CCW	counter-clockwise

CGSB	Canadian General Standards Board
DCDI	Dual Capacitor Discharge Ignition
DC	direct current
DOA	Design Organisation Approval
DOT	Department of Transport
EASA	European Aviation Safety Agency
IM	Installation Manual
ECU	Engine Control Unit
EGT	Exhaust Gas Temperature
INTRO	Introduction
EMS	Engine Management System
EN	European Norm
ETFE	Ethylene Tetrafluoroethylene
FAA	Federal Aviation Administration
FAR	Federal Aviation Regulations
hr.	hours
HIC A	Harness Interface Connector A
HIC B	Harness Interface Connector B
IFR	Instrument Flight Rules
INJ 1–8	Injector 1–8
IPC	Illustrated Parts Catalog
ips	inch per second
iRMT	independent ROTAX Maintenance Technician
TOC	Table of content
ISA	International Standard Atmosphere
kg	Kilograms
KNOCK	Knock sensor
MAPS 1+2	Manifold Air Pressure Sensor 1+2
MATS 1+2	Manifold Air Temperature Sensor 1+2
MS	Magneto Side
MON	Motor Octane Number

N	Newton
n.a.	not available
NDT	Non Destructive Testing
Nm	Newtonmeter
NVFR	Night Visual Flight Rules
OHM	Overhaul Manual
OHV	Over Head Valve
OM	Operators Manual
OPS	Oil Pressure Sensor
OTS	Oil Temperature Sensor
PCV	Pressure Control Valve
POA	Production Organisation Approval
PTFE	Polytetrafluoroethylene
PTO	Power Take Off
Rev.	Revision
ROTAX®	is a trademark of BRP-Rotax GmbH & Co KG
RON	Research Octane Number
s.v.	still valid (only Illustrated Parts Catalog)
S/N	Serial Number
SAE	Society of Automotive Engineers
SB	Service Bulletin
SI	Service Instruction
SL	Service Letter
SMD	Service Mounted Devices
TBO	Time Between Overhaul
TC	Type certificate
part no.	Part number
TOA	Table Of Amendment
TSN	Time Since New
TSNP	Time Since New Part
TSO	Time Since Overhaul
V	Volt

VFR	Visual Flight Rules
LEP	List of Effective Pages
MM	Maintenance Manual
XXX	shows the serial component number

1.3) Safety

Although reading such information does not eliminate any hazards, it promotes the understanding and application the information will promote correct use of the engine. Always apply common workshop safety rules.

The information and descriptions of components and systems contained in this Manual are correct at the time of publication. BRP-Rotax maintains a policy of continuous improvement of its products without imposing upon itself any obligation to retrofit products previously manufactured.

Revisions

BRP-Rotax reserves the right to remove, replace or discontinue any design, specification, feature or other at any time, and without incurring obligation.

Measurement

Specifications are given in the SI metric system with the imperial- and US customary measurement system equivalents in parenthesis.

Symbols used

This Manual uses the following symbols to emphasize particular information. This information is important and must be observed.

⚠ WARNING

Identifies an instruction which, if not followed, may cause serious injury or even fatal injury.

⚠ CAUTION

Identifies an instruction which, if not followed, may cause minor or moderate injury.

ATTENTION

Identifies an instruction which, if not followed, may severely damage the engine or could lead to suspension of warranty.

NOTE

Indicates supplementary information which may be needed to fully complete or understand an instruction.

ENVIRONMENT NOTE

Environmental notes give you tips on environmental protection.

A revision bar outside the page margin indicates a change to text or graphic.

1.4) Safety information

Use for intended purpose

⚠ WARNING

Non-compliance can result in serious injuries or death!

Never fly the aircraft equipped with this engine at locations, air speeds, altitudes or in other situations which do not allow a successful no-power landing after sudden engine stoppage.

- This engine is not suitable for acrobatics (inverted flight, etc.). Flight attitudes outside the permissible limits are not allowed.
- This engine shall not be used on rotorcrafts with an in-flight driven rotor (e.g. helicopters).
- It should be clearly understood that the choice, selection and use of this particular engine on any aircraft is at the sole discretion and responsibility of the aircraft manufacturer, assembler and owner/user.
- Due to the varying designs, equipment and types of aircraft, BRP-Rotax grants no warranty on the suitability of its engines use on any particular aircraft. Further, BRP-Rotax grants no warranty on this engines suitability with any other part, components or system which may be selected by the aircraft manufacturer, assembler or user for aircraft application.

⚠ WARNING

Non-compliance can result in serious injuries or death!

For each use of DAY VFR, NIGHT VFR or IFR in an aircraft the applicable legal requirements and other existing must be adhered to.

- Certain areas, altitudes and conditions present greater risk than others. The engine may require humidity or dust/sand preventative equipment, or additional maintenance may be required.
 - You should be aware that any engine may seize or stall at any time. This could lead to a crash landing and possible severe injury or death. For this reason, we recommend strict compliance with the maintenance and operation and any additional information which may be given to you by your dealer.
- Training**
- Whether you are a qualified pilot or a novice, complete knowledge of the aircraft, its controls and operation is mandatory

before a solo flight. Flying any type of aircraft involves a certain amount of risk. Be informed and prepared for any situation or hazard associated with flying.

- A recognized training program and continued education for piloting an aircraft is absolutely necessary for all aircraft pilots. Make sure you also obtain as much information as possible about your aircraft, its maintenance and operation from your dealer.
- Engine-specific training courses are provided by the authorized distributors according to manufacturer specifications (iRMT).

Regulations

- Respect all legal requirements or local rules pertaining to flight operation in your flying area. Only fly when and where conditions, topography, and airspeeds are safest.
- Consult your aircraft dealer or manufacturer and obtain the necessary information, especially before flying in new areas.

Instrumentation

- Select and use proper aircraft instrumentation. This instrumentation is not included in the ROTAX® engine package. Verification to the latest regulations such as FAR or EASA has to be conducted by the aircraft manufacturer.

Engine log book

- Keep an engine log book and respect engine and aircraft maintenance schedules. Keep the engine in top operating condition at all times. Do not operate any aircraft which is not properly maintained or has engine operating irregularities which have not been corrected.

Maintenance (iRMT)

- Since special training, tools and equipment are required, engine servicing shall only be performed by an authorized ROTAX® aircraft engine distributor or their independent service center. BRP-Rotax requires that any service or maintenance work carried out and verified by a technician that has a current iRMT rating.
- When the engine will not be operated for a longer period protect the engine and fuel system from contamination and environmental exposure.

Engine operation

- Never operate the engine without sufficient quantities of operating fluids (oil, coolant, fuel).
- Never exceed the maximum permitted operational limits.
- In the interest of safety, the aircraft must not be left unattended while the engine is running.
- To eliminate the risk of injury or damage, ensure any loose equipment or tools are properly secured before starting the engine.

Vacuum pump

- Allow the engine to cool at idle for several minutes before turning off the engine.
- This engine may be equipped with a vacuum pump. The safety warning accompanying the vacuum pump must be given to the owner/operator of the aircraft into which the vacuum pump is installed.

1.5) Technical documentation

These documents form the instructions ensuring continued airworthiness of ROTAX® aircraft engines.

The information contained herein is based on data and experience that are considered applicable for authorized mechanics (iRMT, see Maintenance Manual Line) under normal conditions. Due to the fast technical progress and fulfillment of particular specifications of the customers it may occur that existing laws, safety prescriptions, constructional and operational regulations may not be sufficient or cannot be transferred completely to the object bought, in particular for special constructions.

Documentation

- Installation Manual
- Operators Manual
- Maintenance Manual (Line and Heavy Maintenance)
- Overhaul Manual
- Illustrated Parts Catalog
- Alert Service Bulletins
- Service Bulletins
- Service Instructions
- Service Letters



Status

The status of Manuals can be determined by checking the table of amendments. The first column of this table indicates the revision status which should be compared with the revision provided on the ROTAX®-Website: www.FLYROTAX.com Amendments and current versions can be downloaded free of charge.

Replacement pages

Furthermore the Manual is constructed in such a way that single pages can be replaced instead of the complete document. The list of effective pages is given in the chapter LEP. The particular edition and revision number is given on the footer of each page.

Reference

Any reference to a document refers to the latest edition issued by BRP-Rotax if not stated otherwise.

Illustrations

The illustrations in this Manual are merely sketches and show typical arrangements. They may not represent full detail or the exact shape of the parts but should outline the same or similar function. Therefore deriving dimensions or other details from illustrations is not permitted.

TYPICAL indicates a general view which may not represent exact details..

NOTE

The Illustrations in this Manual are stored in a graphic data base system and are provided with a consecutive irrelevant number.

This number (e.g. AE 5iS001) is of no significance for the content.

1.6) Standard version

Basic

- 4 stroke, 4 cyl. horizontally opposed, spark ignition engine, single central camshaft hydraulic tappets - push rods - OHV
- Liquid cooled cylinder heads
- Ram air cooled cylinders
- Dry sump forced lubrication
- Dual ignition of breakerless, capacitor discharge design
- 2 constant depression carburetors
- Mechanical fuel pump
- Electric starter (12 V 0.7 kW), 912 S/ULS (12 V 0.9 kW)
- Integrated AC generator with external rectifier regulator
- Propeller drive via integrated gearbox with mechanical shock absorber and overload clutch

NOTE

The overload clutch is installed on all serial production aircraft engines which are certified and non-certified aircraft engines of the configuration 3.

Optional

- Electric starter (12 V 0.9 kW)
- External alternator (12 V 40 A DC)
- Vacuum pump drive
- Hydraulic constant speed propeller governor drive

1.6.1) Auxiliary equipment (optional)

Any equipment not included as part of the standard engine version and thus not a fix component of the engine is not in the volume of supply.

Components especially developed and tested for this engine are readily available at BRP-Rotax.

Auxiliary equipment certified

The following auxiliary equipment has been developed and tested for this engine.

- Airbox
- External alternator
- Engine suspension frame
- Vacuum pump (feasible on configuration 2)
- Drive for rev counter/hour-meter

- Oil radiator with connection
- Coolant radiator
- Coolant overflow bottle

Auxiliary equipment not certified

The following auxiliary equipment has not been developed and tested for this engine.

- Exhaust system
- Intake filter
- Mechanical rev counter
- Shock mount

1.7) Type description

The type description consists of the following:

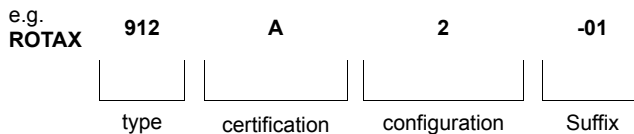

Designation

Designation		Description
Type	912	4 –cyl. horizontally opposed, normal aspirated engine
Certification	A	Certified to JAR 22 (TC No. EASA.E.121)
	F, S	Certified to FAR 33 (TC No. E00051 EN) JAR-E (TC No. EASA.E.121)
	UL, ULS	Non-certified aircraft engines
Configuration	2	Prop shaft with flange for fixed pitch propeller.
	3	Prop shaft with flange for constant speed propeller and drive for hydraulic governor for constant speed propeller.
Suffix	-XX	Explanation of the type designation suffix, see SB-912-068

Options

Available options (optional equipment) for the engine type mentioned above:

	external alternator	vacuum pump	drive for rev counter/ hour meter	governor
for configuration 2	yes	yes	yes	no
for configuration 3	yes	no	yes	yes

NOTE

Conversion of the configuration 2 to configuration 3 may be accomplished by ROTAX® authorized aircraft engines distributors or their Independent service centers.

1.8) Engine components, engine views, cylinder designation

Side view

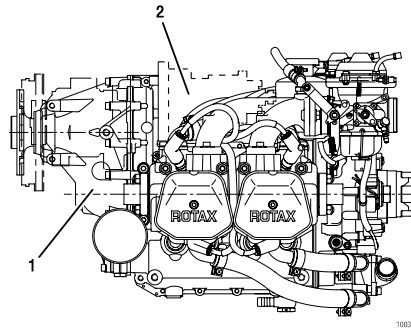

Figure .2: Side view engine

- | | | | |
|---|--------------------|---|--|
| 1 | Propeller gear box | 2 | Vacuum pump or hydraulic governor for constant speed propeller |
|---|--------------------|---|--|

Top view

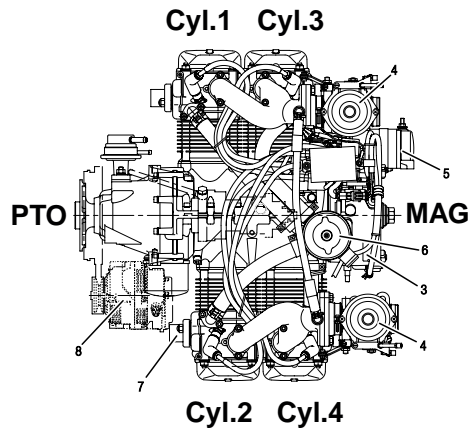

Figure .3: Top view engine

- | | | | |
|---|----------------------|---|---|
| 3 | Engine serial number | 4 | CD carburetor |
| 5 | Electric starter | 6 | Expansion tank with excess pressure valve |
| 7 | Exhaust flange | 8 | External alternator |

Front view

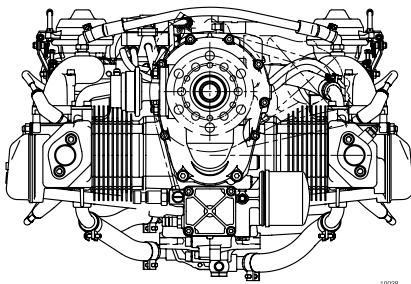

Figure .4: Front view engine

1.9) Technical data

Description	912 A/F/UL	912 S/ULS
Bore	79.5 mm (3.13 in)	84 mm (3.31 in)
Stroke	61 mm (2.40 in)	61 mm (2.40 in)
Displacement	1211 cm ³ (73.9 in ³)	1352 cm ³ (82.5 in ³)
Compression ratio.	9.0 : 1	10.8 : 1

1.10) Fuel consumption

Fuel consumption	912 A/F/UL	912 S/ULS
At take-off performance	24.0 l/h (6.3 gal/h)	27.0 l/h (7.1 gal/h)
At max. continuous performance	22.6 l/h (5.6 gal/h)	25.0 l/h (6.6 gal/h)
At 75 % continuous performance	16.2 l/h (4.3 gal/h)	18.5 l/h (4.9 gal/h)
Specific consumption at max. continuous performance	285 g/kWh (0.47 lb/hph)	285 g/kWh (0.47 lb/hph)

1.11) Direction of rotation

Direction of rotation

Direction of rotation on propeller shaft: counter clockwise, viewed from the front.

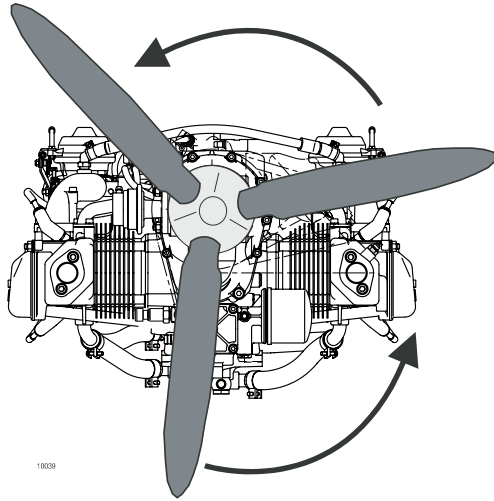

Figure .5: Normal direction of propeller rotation (engine)

NOTES

2) Operating instructions

Topics in this chapter

2.1 Operating limits (912 A/F/UL).....	2
2.2 Operating limits (912 S/ULS)	5
2.3 Operating media-Coolant.....	8
2.4 Operating media – Fuel.....	9
2.5 Operating media-Lubricants.....	10

Introduction

The data of the certified engine are based on the type certificate of type 912 A JAR 22 (TC No. EASA.E.121), 912 F/S FAR 33 (TC No. E00051 EN), JAR-E (TC No. EASA.E. 121).

This chapter of the Operators Manual contains the operating limits that must be observed to ensure the ROTAX® aircraft engine and standard systems operate safely.

2.1) Operating limits (912 A/F/UL)

Performance

Performance data relate to ISA (International Standard Atmosphere) conditions without Governor, external alternator etc.

Take-off performance	59.6 kW at 5800 rpm
Max. continuous performance	58 kW at 5500 rpm

Speed

Speed	
Take-off speed	5800 rpm (max. 5 min.)
Max. continuous speed	5500 rpm
Idle speed	min. 1400 rpm

Acceleration

Limit of engine operation at zero gravity and in **negative "g"** condition.

Max: 5 seconds at max. -0.5g.

Oil pressure

Oil pressure	
Max.	7 bar (102 psi)
Min.	0.8 bar (12 psi) (below 3500 rpm) 1.5 bar (22 psi) ¹
Normal	2.0 to 5.0 bar (27–73 psi) (above 3500 rpm) 1.5 to 5.0 bar (22 psi-73 psi) ¹

ATTENTION

Oil pressure max. for a short period admissible at cold start.

Oil temperature

Oil temperature	
Max.	140 °C (285 °F)
Min.	50 °C (120 °F)
normal operating temperature approx. 90 to 110 °C (190-230 °F)	

1. 912 UL to S/N 4 402 387/912 A to S/N 4 410 266 /912 F to S/N 4 412 764

EGT

Exhaust gas temperature	
Max.	880 °C (1616 °F)

Conventional coolant

Applicable for engine S/N without Suffix -01. [See also Chapter 2.3.](#)

Coolant temperature: (coolant exit temperature)	
Max.	120 °C (248 °F)

Cylinder head temperature:	
Max.	150 °C (300 °F)
Permanent monitoring of coolant temperature and cylinder head temperature is necessary.	

Waterless coolant

[See also Chapter 2.3](#)

Cylinder head temperature:	
Max.	150 °C (300 °F)
Permanent monitoring of cylinder head temperature is necessary.	

Conventional coolant

[See also Chapter 2.3](#)

Applicable for engine S/N with Suffix -01.

Coolant temperature limit measured in the cylinder head	Engine type
Max. 120 °C (248 °F)	912 A/F/UL
Permanent monitoring of coolant temperature is necessary.	

Engine start, operating temperature

Max.	50 °C (120 °F) (ambient temperature)
Min.	-25 °C (-13 °F) (oil temperature)

Fuel pressure

⚠ WARNING

Non-compliance can result in serious injuries or death!
Fuel pressure in excess of stated limit can lead to an override of the float valve with subsequent engine stop.

The aircraft engine manufacturer strongly recommends the installation of an additional pump, unless this has not been covered by legal obligations so far.

Fuel pressure	
Max.	0.4 bar (5.8 psi) (0.5 bar (7.26 psi)) ²
Min.	0.15 bar (2.2 psi)

Propeller governor

Power consumption of the hydraulic propeller governor:

Max.	600 W
------	-------

Vacuum pump

Power consumption of the vacuum pump:

Max.	300 W
------	-------

External alternator

Power consumption of the external alternator:

Max.	1200 W
------	--------

Bank angle

Deviation from bank angle:

Max.	40°
------	-----

NOTE

Up to this value the dry sump lubrication system warrants lubrication in every flight situation.

2. applicable only for fuel pump from S/N 11.0036

2.2) Operating limits (912 S/ULS)

Performance

Performance data relate to ISA (International Standard Atmosphere) conditions without Governor, external alternator etc.

Take-off performance	73.5 kW at 5800 rpm
Max. continuous performance	69 kW at 5500 rpm

Speed

Speed	
Take-off speed	5800 rpm (max. 5 min.)
Max. continuous speed	5500 rpm
Idle speed	min. 1400 rpm

Acceleration

Limit of engine operation at zero gravity and in **negative** „g“ condition.

Max. 5 seconds at max. -0.5 g

Oil pressure

Oil pressure	
Max.	7 bar (102 psi)
Min.	0.8 bar (12 psi) (below 3500 rpm)
Normal	2.0 to 5.0 bar (29-73 psi) (above 3500 rpm)

ATTENTION

Oil pressure max. for a short period admissible at cold start.

Oil temperature

Oil temperature	
Max.	130 °C (266 °F)
Min.	50 °C (120 °F)
normal operating temperature: approx. 90 to 110 °C (190-230 °F)	

EGT

Exhaust gas temperature	
Max.	880 °C (1616 °F)

Conventional coolant

See also [Chapter 2.3](#).

Applicable for engine S/N without Suffix -01.

Coolant temperature: (coolant exit temperature)	
Max.	120 °C (248 °F)

Cylinder head temperature	
Max.	135 °C (275 °F)
Permanent monitoring of coolant temperature and cylinder head temperature is necessary.	

Waterless coolant

Cylinder head temperature	
Max.	135 °C (275 °F)
Permanent monitoring of cylinder head temperature is necessary.	

Conventional coolant

Applicable for engine S/N with Suffix -01.

Coolant temperature limit measured in cylinder head	Engine type
Max. 120 °C (248 °F)	912 S/ULS
Permanent monitoring of coolant temperature is necessary.	

Engine start, operating temperature

Max.	50 °C (120 °F) (ambient temperature)
Min.	-25 °C (-13 °F) (Oil temperature)

Fuel pressure

⚠ WARNING

Non-compliance can result in serious injuries or death!
Exceeding the max admissible fuel pressure will override the float valve of the carburetor and to engine failure.

The aircraft engine manufacturer strongly recommends the installation of an additional pump, unless this has not been covered by legal obligations so far.

Fuel pressure	
Max.	0.4 bar (5.8 psi) (0.5 bar (7.26 psi)) ³
Min.	0.15 bar (2.2 psi)

Propeller governor

Power consumption of the hydraulic propeller governor:

Max.	600 W
------	-------

Vacuum pump

Power consumption of the vacuum pump:

Max.	300 W
------	-------

External alternator

Power consumption of the external alternator:

Max.	1200 W
------	--------

Bank angle

Deviation from bank angle:

Max.	40°
------	-----

NOTE

Up to this value the dry sump lubrication system warrants lubrication in every flight situation.

3. applicable only for fuel pump from S/N 11.0036

2.3) Operating media-Coolant

ATTENTION

Obey the latest edition of Service Instruction SI-912-016, for the selection of the correct coolant.

Conventional coolant

Conventional coolant mixed with water has the advantage of a higher specific thermal capacity than water-less coolant.

Application

When correctly applied, there is sufficient protection against vapor bubble formation, freezing or thickening of the coolant within the operating limits.

Use the coolant specified in the manufacturers documentation.

Mixture

ATTENTION

Obey the manufacturers instructions!

Applicable for engine S/N without Suffix -01.

Designation	Mixture ratio %	
	Concentrate	Water
conventional e.g. BASF Glysantine anticorrosion	50*	50
waterless e.g. Aero Cool 180°	100	0

* coolant component can be increased up to max. 65 %.

Applicable for engine S/N with Suffix -01.

Designation	Mixture ratio %	
	Concentrate	Water
conventional e.g. BASF Glysantine anticorrosion	50*	50

* coolant component can be increased up to max. 65 %.

2.4) Operating media – Fuel

ATTENTION

Obey the latest edition of Service Instruction SI-912-016, for the selection of the correct coolant.

ATTENTION

Use only fuel suitable for the respective climatic zone.

NOTE

Risk of vapour formation if using winter fuel for summer operation.

Antiknock properties

The fuels with following specifications can be used.

	Usage/Description	
	912 A/F/UL	912 S/ULS
	Anti knock properties	Min. RON 90 (min. AKI ⁴)

NOTE

For fuels according to ASTM D4814 specifications following AKI (Anti Knock Index) value has to be observed: min. AKI 91.

MOGAS

MOGAS	Usage/Description	
	912 A/F/UL	912 S/ULS
European standard	EN 228 normal EN 228 super EN 228 super plus	EN 228 super EN 228 super plus

AVGAS

AVGAS 100LL places greater stress on the valve seats due to its high lead content and forms increased deposits in the combustion chamber and lead sediments in the oil system.

4. Anti Knock Index (RON+MON)/2

AVGAS	Usage/Description	
	912 A/F/UL	912 S/ULS
Aviation Standard	AVGAS 100 LL (ASTM D910)	AVGAS 100 LL (ASTM D910)

2.5) Operating media-Lubricants

ATTENTION

Obey the manufacturers instructions about the lubricants.
If the engine is mainly run on AVGAS more frequent oil changes will be required. See Service Information SI-912-016, latest edition.

Oil type	At the selection of suitable lubricants refer to the additional information in the Service Information SI-912-016, latest edition.
Oil consumption	Max. 0.06 l/h (0.13 liq pt/h)
Oil specification	<ul style="list-style-type: none"> • Use only oil with RON 424 classification • Due to the high stresses in the reduction gears, oils with gear additives such as high performance motor cycle oils are required. • Because of the incorporated overload clutch, oils with friction modifier additives are unsuitable as this could result in clutch slippage during normal operation. • Heavy duty 4-stroke motor cycle oils meet all the requirements. These oils are normally not mineral oils but semi- or full synthetic oils. • Oils primarily for Diesel engines have insufficient high temperature properties and additives which favour clutch slipping, and are generally unsuitable.
Oil viscosity	Use of multi-grade oils is recommended.

NOTE

*Multi-viscosity grade oils are less sensitive to temperature variations than single grade oils.
They are suitable for use throughout the seasons, ensure rapid lubrication of all engine components at cold start and get less fluid at higher temperatures.*

Table of lubrication	Since the temperature range of neighboring SAE grades overlap, there is no need for change of oil viscosity at short duration of ambient temperature fluctuations.
-----------------------------	--

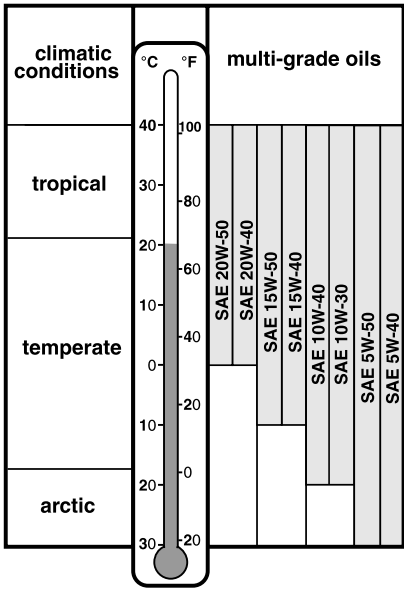

AE 2_0064

Figure .1: Temperature range

NOTES

3) Standard operation

Topics in this chapter

3.1 Daily checks	2
3.2 Before engine start	5
3.3 Pre-flight checks	5
3.4 Engine start	6
3.5 After engine start	8
3.6 Take-off	9
3.7 Cruising	9
3.8 Engine shut-off.....	10
3.9 Cold weather operation	10

Introduction

To warrant reliability and efficiency of the engine, meet and carefully observe all the operating and maintenance instructions.

The following description of procedures depends on the respective type of installation in the aircraft and shall therefore only be seen functionally.

3.1) Daily checks

Safety

To warrant reliability and efficiency of the engine, meet and carefully observe all the operating and maintenance instructions.

⚠ WARNING

Risk of burnings and scalds! Hot engine parts!
Conduct checks on the cold engine only!

⚠ WARNING

Non-compliance can result in serious injuries or death!
Ignition "OFF" Before moving the propeller switch off both ignition circuit and secure the aircraft. Have the cockpit occupied by a competent person.

ATTENTION

If established abnormalities (e.g. excessive resistance of the engine, noise etc.) inspection in accordance with the relevant Maintenance Manual is necessary. Do not release the engine into service before rectification.

Coolant level

ATTENTION

Operating media are to be observed!

The coolant specifications of the section [Chapter 2.3](#).

Step	Procedure
1	Verify coolant level in the expansion tank , replenish as required up to top. The max. coolant level must be flush with the bottom of the filler neck.
2	Verify coolant level in the overflow bottle , replenish as required. The coolant level must be between max. and min. mark.

ENVIRONMENT NOTE

Protect the environmental!
Never spill any coolant. Dispose of the coolant in an environmentally sound way!

Expansion tank

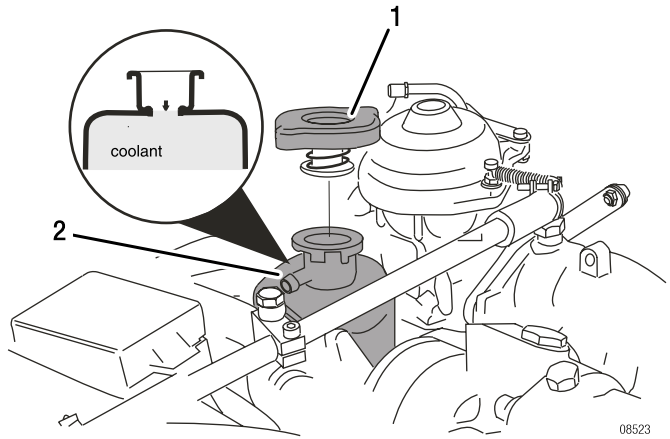

08523

Figure .1: Expansion tank

1 Radiator cap

2 Expansion tank

Overflow bottle

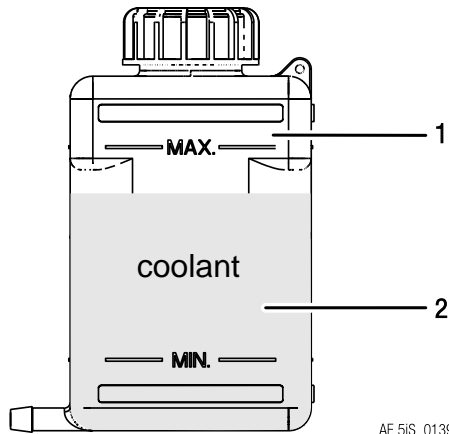

AE 5IS_0139

Figure .2: Overflow bottle

1 Overflow bottle

2 Coolant

Mech./electronic components

Check of mechanical/electronic components.

Step	Procedure
1	Turn propeller slowly by hand in direction of engine rotation several times and observe engine for odd noises or excessive resistance and normal compression.

Gear box

Version **without** overload clutch:
No further checks are necessary.

Version **with** overload clutch:

Step	Procedure
1	Turn the propeller by hand to and fro, feeling the free rotation of 30° before the crankshaft starts to rotate. If propeller can be turned between the dogs frictionless (lower than 25 Nm (19 ft.lb)), further inspection is required.

Carburetor

Step	Procedure
1	Verify free movement of throttle cable and starting carburetor over the complete range. Check from the cockpit.

Exhaust system

Step	Procedure
1	Inspect for damages, leakage and general condition.

3.2) Before engine start

Carry out pre-flight checks.

3.3) Pre-flight checks

Safety

⚠ WARNING
Risk of burnings and scalds! Hot engine parts! Conduct checks on the cold engine only!

Operating media

Step	Procedure
1	Check for any oil-, coolant- and fuel leaks. If leaks are evident, rectify and repair them before next flight.

Oil level

ATTENTION
Operating media are to be observed!

The oil specifications of the [Chapter 2.5](#).

Step	Procedure
1	NOTE <i>Propeller shouldn't be turned excessively reverse the normal direction of engine rotation.</i> Remove bayonet cap, turn the propeller slowly by hand in direction of engine rotation several times to pump oil from the engine into the oil tank.
2	It is essential to build up compression in the combustion chamber. Maintain the pressure for a few seconds to let the gas flow via the piston rings into the crankcase. The speed of rotation is not important but the pressure and the amount of gas which is transferred into the crankcase.
3	This process is finished when air is returning back to the oil tank and can be noticed by a gurgle from the open oil tank.
4	Check oil level and add oil if necessary.
5	Install bayonet cap.

NOTE

The oil level should be in the upper half (between the “50%“ and the “max“ mark) and should never falls below the “min.“ mark. Prior to long flights oil should be added so that the oil level reaches the “max“ mark.

Avoid oil levels exceeding the “max“ mark, since excess oil could be poured out through the venting system.

Difference between max.- and min.- mark = 0.45 litre (0.95 liq pt).

ENVIRONMENT NOTE

Protect the environmental.

Observe to bury no oil! Dispose of oil in an environmentally friendly manner.

3.4) Engine start

⚠ WARNING

Non-compliance can result in serious injuries or death!

Do not start the engine if any person is near the running engine.

Engine start

Step	Designation	Procedure
1	Fuel valve	open
2	Starting carb	activated
	IF engine in operating temperature	Then start the engine without choke.
3	Throttle lever	set on idle position
4	Master switch	ON
5	Ignition	both circuits switched on

ATTENTION

Do not actuate starter button (switch) as long as the engine is running. Wait until complete stop of engine!

Step	Designation	Procedure
6	Starter button	actuate

ATTENTION

Activate starter for maximum of 10 seconds only (without interruption), followed by a cooling period of 2 minutes.

Step	Designation	Procedure
7	As soon as engine runs	adjust throttle to achieve smooth running at approx. 2500 rpm.
8	Oil pressure	check if oil pressure has risen within 10 seconds and monitor oil pressure. Increase of engine speed is only permitted at steady oil pressure readings above 2 bar (30 psi).

ATTENTION

At an engine start with low oil temperature, continue to observe the oil pressure as it could drop again due to the increased flow resistance in the suction line. The number of revolutions may be only so far increased that the oil pressure remains steady.

Step	Designation	Procedure
9	Starting carb (choke)	de-activate

To observe

Reduction gear with shock absorber

ATTENTION

Since the engine comprises a reduction gear with shock absorber, take special care of the following:

Step	Procedure
1	To prevent impact load, start with throttle lever in idle position or at the most up to 10% open.
2	For the same reason, wait for around 3 sec. after throttling back to partial load to reach constant speed before re-acceleration..
3	For checking the two ignition circuits, only one circuit may be switched off and on at a time.

3.5) After engine start

⚠ WARNING

Non-compliance can result in serious injuries or death!
Do not start the engine if any person is near the running engine.

Warming up period

Step	Procedure
1	Start warming up period at approx. 2000 rpm for approx. 2 minutes.
2	Continue at 2500 rpm, duration depending on ambient temperature, until oil temperature reaches 50 °C (120 ° F).
3	Check temperatures and pressure.

Throttle response

ATTENTION

After a full-load ground test allow a short cooling run at idle speed to prevent vapour formation in the cylinder head.

Step	Procedure
1	Short full throttle ground test (consult Aircraft Operators Manual since engine speed depends on the propeller used).

Ignition check

Check the two ignition circuits at **4000 rpm** (approx. 1700 rpm propeller).

Step	Procedure
1	Speed drop with only one ignition circuit must not exceed 300 rpm (approx. 130 rpm propeller).
2	115 rpm (approx. 50 rpm propeller) max. difference of speed by use of either circuit, A or B.

NOTE

The propeller speed depends on the actual reduction ratio.

Propeller governor

Check of hydraulic propeller governor:

Check control of the hydraulic propeller governor to specifications of the manufacturer.

NOTE

Cycling the propeller governor puts a relatively high load on the engine. Unnecessary cycling or additional checks should be avoided.

3.6) Take-off

⚠ WARNING

Non-compliance can result in serious injuries or death!
Monitor Operating limits. Limits must not be exceeded.

Climb

Climbing with engine running at take-off performance is permissible (max. 5 minutes).
See [Chapter 2.1 Operating limits](#)

3.7) Cruising

Performance

Step	Procedure
1	Set performance as per performance specifications Chapter 5 and respect operating limits as per Chapter 2.1 Operating limits .

Oil temperature

Step	Procedure
1	Avoid operation below normal operation oil temperature (90 to 110 °C / 194 to 230 °F), as possible formation of condensation water in the lubrication system badly influences the oil quality. To evaporate possibly accumulated condensation water, at least once a day 100 °C (212 °F) oil temperature must be reached.

3.8) Engine shut-off

Normally the cooling down of the engine during descending and taxiing will be sufficient to allow the engine to be shut off as soon as the aircraft is stopped.

At increased operating temperatures make an engine cooling run of at least minimum 2 minutes.

3.9) Cold weather operation

Generally, an engine service should be carried out before the start of the cold season.

Coolant

For selection of coolant and mixing ratio, see [Chapter 2.3](#).

Lubricant

For selection of oil, see table of Lubricants [Chapter 2.5](#).

Cold start

- With throttle closed and choke activated (open throttle renders starting carb ineffective)
- Be aware, no spark below crankshaft speed of 220 rpm (propeller speed of 90 rpm)
- As performance of electric starter is greatly reduced when hot, limit starting to periods not much longer than 10 sec. With a well charged battery, adding a second battery will not improve cold starts

Remedy - Cold start

Step	Procedure
1	Use of multigrade oil with the low end viscosity code of 5 or 10.
2	Check electrode gap of spark plugs and set it to the minimum or fit new spark plugs.
3	Preheat engine.

Icing in the air intake system

Icing due to humidity.

Carburetor icing due to humidity may occur on the venturi and on the throttle valve due to fuel evaporation and leads to performance loss and change in mixture.

Remedy

- Intake air pre-heating is the only effective remedy. See Flight Manual supplied by the aircraft manufacturer

Icing

Icing due to water in fuel.

ATTENTION

Fuels containing alcohol always carry a small amount of water in solution. In case of temperature changes or increase of alcohol content, water or a mixture of alcohol and water may settle and could cause troubles.

Water in fuel will accumulate at the lower parts of the fuel system and leads to freezing of fuel lines, filters or jets.

Remedy

- Use non-contaminated fuel (filtered through suede)
- Generously sized water separators
- Fuel lines routing inclined
- Prevent condensation of humidity, i. e avoid temperature differences between aircraft and fuel

NOTES

4) Abnormal operation

Topics in this chapter

4.1 Re-Start during flight	3
4.2 Exceeding max. admissible engine speed	3
4.3 Temperature	3
4.3.1 Exceeding of max. admissible cooling system temperature	3
4.3.2 Exceeding of max. admissible cyl. head temperature	3
4.3.3 Exceeding of max. admissible coolant temperature	4
4.3.4 Exceeding of max. admissible oil temperature	4
4.4 Oil pressure/Fuel pressure	4
4.4.1 Oil pressure below minimum - on ground	5
4.4.2 Oil pressure above permitted range at low ambient temperatures.....	5
4.5 Engine on fire or fire in the engine compartment	5
4.6 Trouble shooting	6

⚠ WARNING

Non-compliance can result in serious injuries or death!
At unusual engine behaviour conduct checks as per Maintenance
Manual Line Chapter 05-50-00 before the next flight.

NOTE

Further checks - see Maintenance Manual.

The following description of procedures depends on the respective type of installation in the aircraft and shall therefore only be seen functionally.

4.1) Re-Start during flight

Engine stop If the propeller continues to rotate during flight by windmilling, but the speed is not sufficient to start the engine, the electric starter can be used without problems. You must not wait until the propeller stands still.

4.2) Exceeding max. admissible engine speed

Exceeding engine speed Reduce the engine speed. Any exceeding of the max. admissible engine speed has to be entered by the pilot into logbook, stating duration and extent of over engine speed.

4.3) Temperature

ATTENTION

Reduce engine power setting to the minimum necessary and carry out precautionary landing.

4.3.1) Exceeding of max. admissible cooling system temperature

ATTENTION

Reduce engine power setting to the minimum necessary and carry out precautionary landing.

4.3.2) Exceeding of max. admissible cyl. head temperature

ATTENTION

Reduce engine power setting to the minimum necessary and carry out precautionary landing.

Cylinder head temperature max.

Applicable for engine S/N without Suffix -01.

- Any exceeding of the max. admissible cylinder head temperature has to be entered by the pilot into the logbook, stating duration and extent of over-temperature condition.
- Carry out an unscheduled maintenance check according to Maintenance Manual Line chapter 05-50-00.

4.3.3) Exceeding of max. admissible coolant temperature

ATTENTION

Reduce engine power setting to the minimum necessary and carry out precautionary landing.

Coolant temperature max.

Applicable for engine S/N with Suffix -01.

- Any exceeding of the max. admissible coolant temperature has to be entered by the pilot into the logbook, stating duration and extent of over-temperature condition.
- Carry out an unscheduled maintenance check according to Maintenance Manual Line chapter 05-50-00.

4.3.4) Exceeding of max. admissible oil temperature

ATTENTION

Reduce engine power setting to the minimum necessary and carry out precautionary landing.

Exceeding oil temperature

- Any exceeding of the max. oil temperature must be entered by the pilot in the logbook, stating duration and extent of over-temperature condition.
- A maintenance inspection should be carried out.

4.4) Oil pressure/Fuel pressure

ATTENTION

Reduce engine power setting to the minimum necessary and carry out precautionary landing.

Oil pressure

Oil pressure below minimum - during flight

- Check oil system.
- A maintenance inspection should be carried out.

4.4.1) Oil pressure below minimum - on ground

ATTENTION

Reduce engine power setting to the minimum necessary and carry out precautionary landing.

Oil pressure too low

Immediately stop the engine and check for reason. Check oil system.

- Check oil quantity in oil tank.
- Check oil quality. See Chapter: Operating media-Lubricants.
- A maintenance inspection should be carried out.

4.4.2) Oil pressure above permitted range at low ambient temperatures

ATTENTION

Reduce engine power setting to the minimum necessary and carry out precautionary landing.

Oil pressure too high

- Reduce engine speed and check the oil pressure again once it has reached a higher oil temperature.
- A maintenance inspection should be carried out.

4.5) Engine on fire or fire in the engine compartment

ATTENTION

Carry out emergency procedures as prescribed in the flight manual of the engine manufacturer.

- After landing locate the cause of fire and resolve the error before next flight by qualified staff (authorized by the Aviation Authorities).
- An entry in the logbook must be made.
- A maintenance inspection should be carried out.

4.6) Trouble shooting

⚠ WARNING

Non-compliance can result in serious injuries or death!
Only qualified staff (authorized by the Aviation Authorities) trained on this particular engine, is allowed to carry out maintenance and repair work.

ATTENTION

If the following hints regarding remedy do not solve the problem, contact an authorized workshop. The engine must not be operated until the problem is rectified.

All checks in accordance with the Maintenance Manual (current issue/revision).

Starting problems

Engine does not start

Possible cause	Remedy
Ignition off.	Switch on.
Closed fuel valve or clogged filter.	Open valve, clean or renew filter, check fuel system for leaks.
No fuel in tank.	Refuel.
Starting speed too low, faulty or discharged battery.	Fit fully charged battery.
Starting speed too low, start problems on cold engine.	Use top quality, low friction oil; allow for sufficient cooling period to counter for performance drop on hot starter; preheat engine.
Wrong fuel (Jetfuel or Diesel).	Change of fuel.

Engine run

Engine keeps running with ignition off

Possible cause	Remedy
Overheating of engine.	Let engine cool down at idling at approx. 2000 rpm.

Knocking under load

Possible cause	Remedy
Octane rating of fuel too low.	Use fuel with higher octane rating.

Engine idles rough after warm-up period, smoky exhaust emission.

Possible cause	Remedy
Starting carb (Choke) activated.	Close starting carb (Choke).

Oil pressure

Low oil pressure

Possible cause	Remedy
Not enough oil in oil tank.	Refill oil.
Too hot oil.	Cool down oil.

High oil pressure

Possible cause	Remedy
Too cold oil	Cover oil cooler or install thermostat.
Wrong viscosity of oil	Change oil to lower viscosity.

Oil level

Oil level is increasing

Possible cause	Remedy
Oil too cold during engine operation.	Cover oil cooler surface, maintain the oil temperature prescribed.
Contamination with diesel fuel.	Check fuel.

Possible cause	Remedy
Starting speed too low.	Preheat engine.
Low charge battery.	Fit fully charged battery.
High oil pressure.	At cold start an oil pressure reading of up to around 7 bar (102 psi) does not indicate a malfunction.
Oil pressure too low after cold start.	Too much resistance in the oil suction system at low temperatures due to cold oil. Stop engine and preheat oil. After a cold start the oil tank must be observed and the oil pressure should be above 1.5 bar (22 psi). Otherwise, the speed must be lowered again, because not enough cold oil can be sucked. If oil pressure is reading lower than 1 bar (15 psi) oils with lower viscosity are to be used. See SI-912 i-001, current issue.

NOTE

Oil pressure must be measured at idle at an oil temperature of minimum 50 °C (120 °F). Be sure the oil pressure does not go below minimum at idle.

5) Performance and Fuel consumption

Topics in this chapter

5.1 Performance data 2

Introduction

The performance and fuel information shown in this chapter are intended to give an indication on the expected power output and fuel consumption of this engine. The actual power and fuel consumption is highly depending on the installation, the compliance to predefined maintenance events and the way the engine is operated. Those values need to be determined and provided by the aircraft manufacturer.

5.1) Performance data

Performance
graphs
Engine 912 A/F/UL

Performance graphs for stand. conditions (ISA)

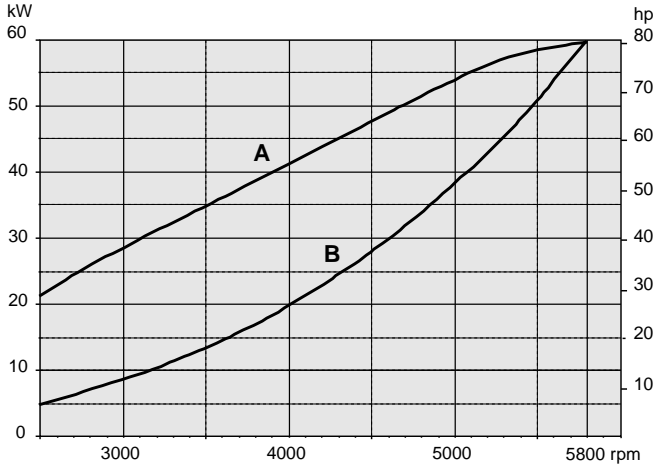

Figure .1: Performance graphs 912 A/F/UL

A max. engine output

B power requirement of propeller

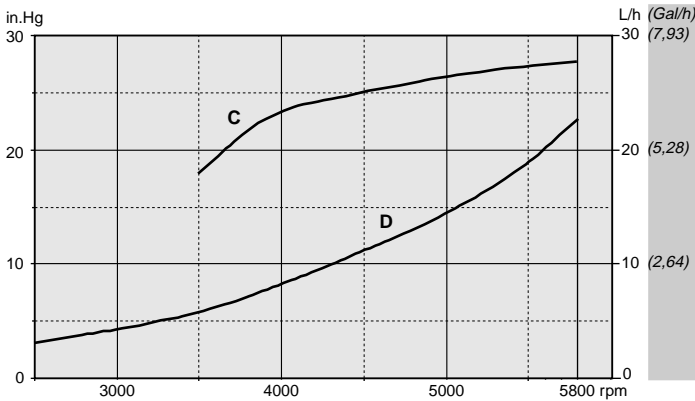

Figure .2: Values along propeller curve

C manifold pressure

D fuel consumption

**Performance data
Engine 912 A/F/UL**

Performance data for variable pitch propeller

Engine speed over 5500 rpm is restricted to 5 minutes.
Run the engine in accordance with the following table.

Power setting	Engine speed (rpm)	Performance (kW)/(HP)	Torque (Nm)/(ft. lb)	Manifold pressure (in. Hg)
Take-off power	5800	59.6 / 80	98.1 / 72.35	full throttle
max. continuous power	5500	58.0 / 78	100.7 / 74.27	full throttle
75 %	5000	43.5 / 58	83.1 / 61.29	27.2
65 %	4800	37.7 / 50	75.0 / 55.32	26.5
55 %	4300	31.9 / 43	70.8 / 52.22	26.3

NOTE

Further essential information regarding engine behavior see Service Letter SL-912-016, latest edition.

**Performance data
Engine 912 A/F/UL**

Performance data variable pitch propeller

The following graph shows the performance drop with increasing flight altitude. The curves show the performance at 5800, 5500, 5000, 4500 and 4000 rpm, at full throttle.

At deviation of temperature conditions from standard atmosphere conditions the engine performance to be expected can be calculated from the performance indicated, multiplied by standard temperature, divided by actual temperature in K.

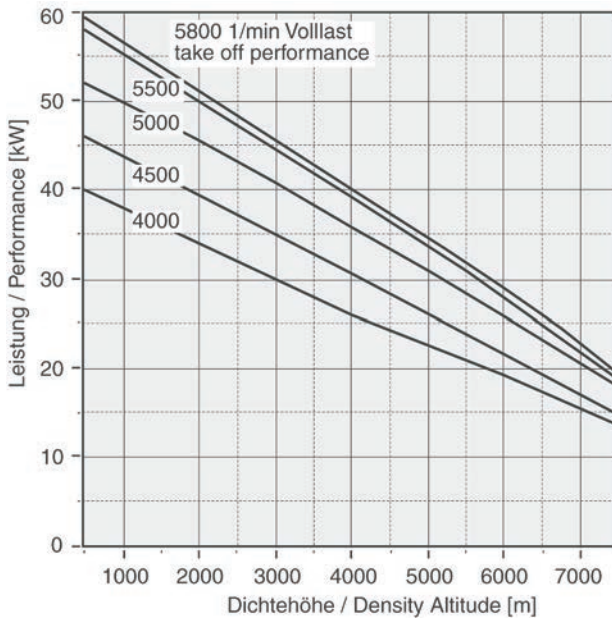

$$P_{akt.} = P_{stand.} \frac{T_{standard}}{T_{aktuell}}$$

$$T [K] = t [^{\circ}C] + 273$$

Figure .3: Performance graphs 912 A/F/UL

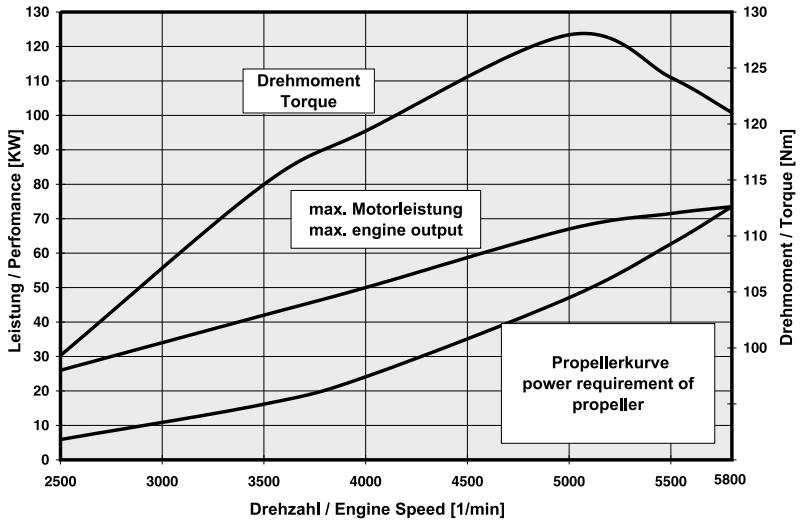

Figure .4: Performance graphs Engine 912 S/ULS

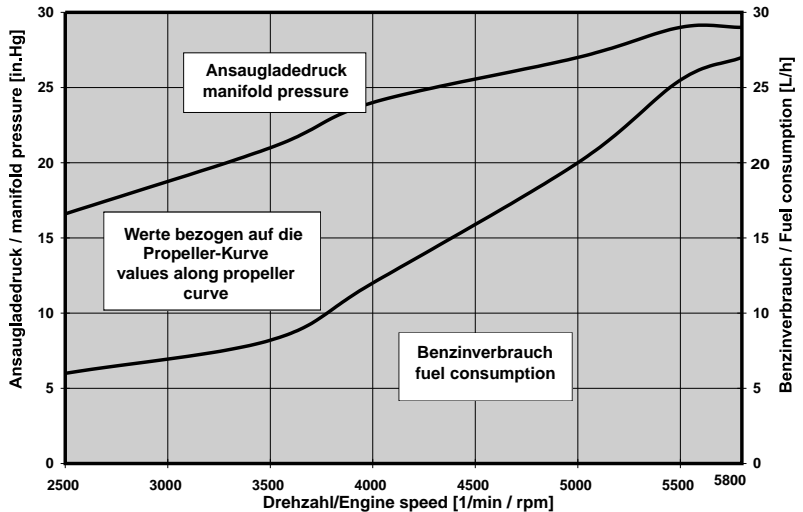

Figure .5: Performance graphs Motor 912 S/ULS

Performance data for variable pitch propeller

Engine speed over 5500 rpm is restricted to 5 minutes.
Run the engine in accordance with the following table.

Power setting	Engine speed (rpm)	Performance (kW) / (HP)	Torque (Nm) / (ft. lb)	Manifold pressure (in.Hg)
Take-off power	5800	73.5 / 100	121.0 / 89.24	27.5
Max. continuous power	5500	69.0 / 90	119.8 / 88.36	27
75 %	5000	51.0 / 68	97.4 / 71.84	26
65 %	4800	44.6 / 60	88.7 / 65.42	26
55 %	4300	38.0 / 50	84.3 / 62.17	24

NOTE

Further essential information regarding engine behavior see Service Letter SL-912-016, latest edition.

The following graph shows the performance drop with increasing flight altitude. The curves show the performance at 5800, 5500, 5000, 4800 and 4300 rpm, at full throttle.

At deviation of temperature conditions from standard atmosphere conditions the engine performance to be expected can be calculated from the performance indicated, multiplied by standard temperature, divided by actual temperature in °K.

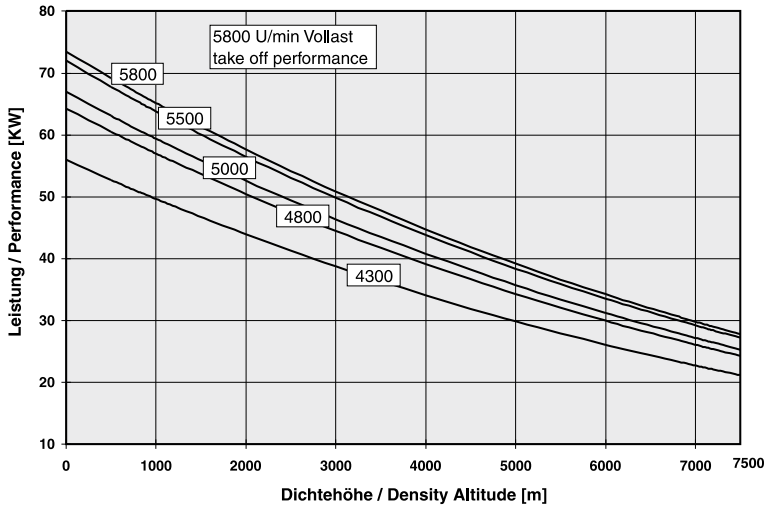

$$P_{akt.} = P_{stand.} \frac{T_{standard}}{T_{aktuel.}}$$

$$T [K] = t [^{\circ}C] + 273$$

Figure .6: Performance graph

NOTES

6) Weights

Topics in this chapter

6.1 Weights – Engine.....	1
6.2 Weight – Accessories.....	1

The stated weights are dry weights (without operating fluids) and are guide values only.

Further weight information relating to the equipment can be found in the current Installation Manual.

6.1) Weights – Engine

Engine

- **with:** electric starter, carburetors, internal generator, ignition and oil tank
- **without:** exhaust system, radiator, airbox

Configuration 2				
912 UL	912 A	912 F	912 ULS	912 S
57.1 kg (126 lb) with overload clutch	57.1 kg (126 lb)	57.1 kg (126 lb)	58.3 kg (128 lb) with overload clutch	58.3 kg (128 lb)
55.4 kg (122 lb) without clutch			56.6 kg (125 lb) without clutch	

Configuration 3				
912 UL	912 A	912 F	912 ULS	912 S
59.8 kg (132 lb)			61.0 kg (134 lb)	

6.2) Weight – Accessories

Accessories

Part	Weight
External alternator	3.0 kg (6.6 lb)
Vacuum pump	0.8 kg (1.8 lb)
Overload clutch	1.7 kg (3.7 lb)

NOTE

The overload clutch is installed on all certified aircraft engines and on non-certified aircraft engines of the configuration 3.

NOTES

7) System Description

Topics in this chapter

7.1 Cooling system	2
7.2 Fuel system	4
7.3 Lubrication system	5
7.4 Electric system.....	6
7.5 Propeller gearbox	7

Introduction

This chapter of the Operator Manual contains information about the general engine specification as well as a description of cooling system, fuel system, lubrication system, electric system and the propeller gearbox.

The system description refers only to the engine and not to a specific application in a particular aircraft. The aircraft manufacturers Operators Manual is therefore definitive in terms of the operation of the engine, as it contains all the aircraft specific instructions.

7.1) Cooling system

System Overview	The cooling system of the engine is designed for liquid cooling of the cylinder heads and ram-air cooling of the cylinders. The cooling system of the cylinder heads is a closed circuit with an expansion tank.
Coolant flow	The coolant flow is forced by a water pump, driven from the camshaft, from the radiator to the cylinder heads. From the top of the cylinder heads the coolant passes on to the expansion tank. Since the standard location of the radiator is below engine level, the expansion tank located on the top of the engine allows for coolant expansion.
Expansion tank	From the expansion tank the coolant is sucked thru the radiator back to the water pump. Additionally the expansion tank is closed by a pressure cap (with excess pressure valve and return valve). At temperature rise of the coolant the excess pressure valve opens and the coolant will flow via hose at atmospheric pressure to the transparent overflow bottle. When the engine is cooling down, the coolant will be sucked back into the cooling circuit.
Coolant temperature measuring	Reading are taken on measuring point of the hottest cylinder head, depending on engine installation.

NOTE

The temperature sensors are located in cylinder head 2 and 3.

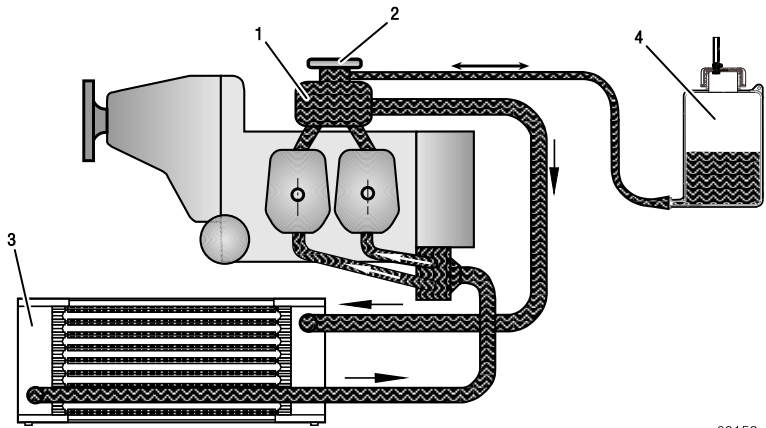

09152

Figure .1: Cooling system

- | | | | |
|---|-----------------------|---|------------------------|
| 1 | <i>Expansion tank</i> | 2 | <i>Pressure cap</i> |
| 3 | <i>Radiator</i> | 4 | <i>Overflow bottle</i> |

7.2) Fuel system

Fuel The fuel flows from the tank via a coarse filter the fire cock and fine filter to the mechanical fuel pump. From the pump fuel passes on via the fuel manifold to the two carburetors.

Return line Via the return line surplus fuel flows back to the fuel tank and suction side of fuel system.

NOTE

The return line serves to avoid formation of vapor lock.

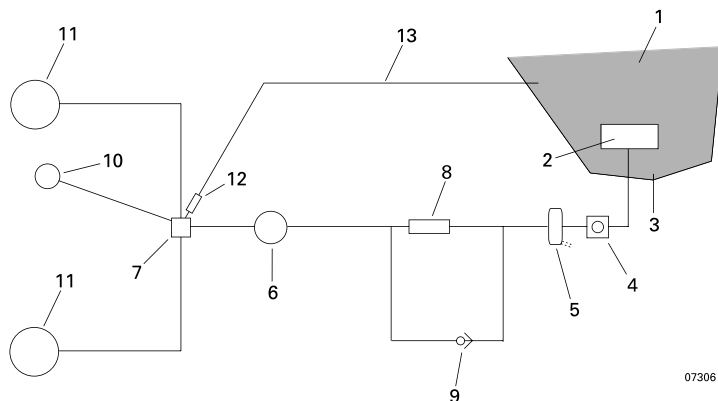

- | | |
|--------------------------------------|-------------------------------------|
| 1 Fuel tank | 2 Coarse filter |
| 3 Drain valve | 4 Fire cock |
| 5 Fine filter/water trap | 6 Mechanical fuel pump ⁵ |
| 7 Fuel pressure control ⁵ | 8 Electrical fuel pump |
| 9 1x check valve | 10 Fuel pressure gauge |
| 11 Carburetor | 12 Restrictor jet |

13 Return line from engine to tank (with integrated adapter sleeve)

Figure .2: Fuel system

5. standard configuration

7.3) Lubrication system

The engines is provided with a dry sump forced lubrication system with a main oil pump with integrated pressure regulator. The airframe manufacturer is responsible for the main layout and the component selection for the lubrication system.

Lubrication

The main oil pump sucks the motor oil from the oil tank via oil radiator and forces it through the oil filter to the points of lubrication.

NOTE

The oil radiator is optional.

Crankcase

The surplus of oil emerging from the points of lubrication accumulates on the bottom of crankcase and is forced back to the oil tank by the piston blow-by gases.

Oil pump

The oil pumps are driven by the camshaft.

Oil circuit vented

The oil circuit is vented via bore on the oil tank.

Oil temperature sensor

The oil temperature sensor for reading of the oil inlet temperature is located on the oil pump housing.

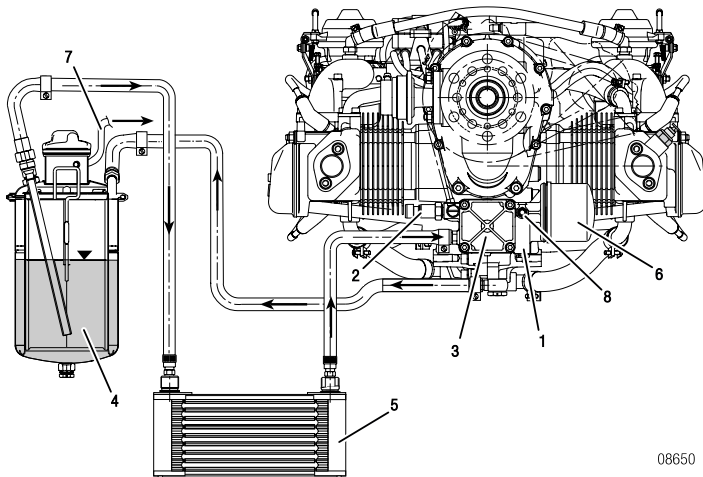

08650

Figure .3: Lubrication system

- | | | | |
|---|--------------------|---|------------------------------|
| 1 | Pressure regulator | 2 | Oil pressure sensor |
| 3 | Oil pump | 4 | Oil tank |
| 5 | Oil radiator | 6 | Oil filter |
| 7 | Venting tube | 8 | Oil temperature sensor (oil) |

7.4) Electric system

The ROTAX® 912 engine is equipped with a dual ignition unit of a breakless, capacitor discharge design, with an integrated generator.

The ignition unit needs no external power supply.

Charging coils

Two independent charging coils located on the generator stator supply one ignition circuit each. The energy is stored in capacitors of the electronic modules. At the moment of ignition 2 each of the 4 external trigger coils actuate the discharge of the capacitors via the primary circuit of the dual ignition coils.

NOTE

The trigger coil is provided for rev counter signal.

Zündfolge: 1 - 4 - 2 - 3

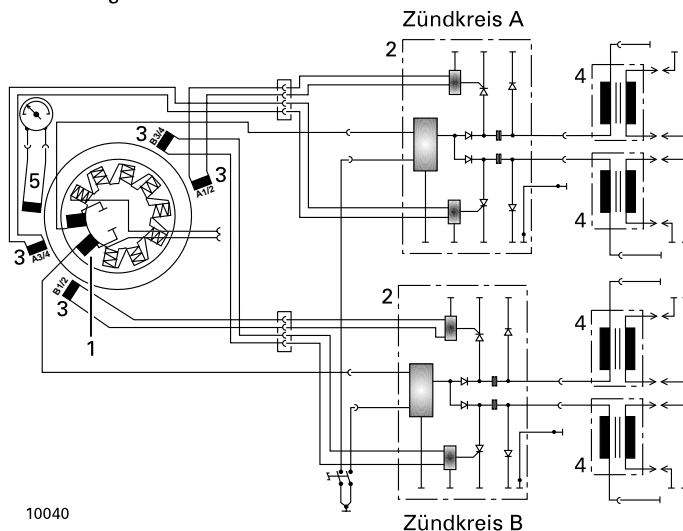

10040

- | | | | |
|---|-----------------------------------|---|---------------------|
| 1 | Charging coils | 2 | Electronic modules |
| 3 | Trigger coils for ignition signal | 4 | Dual ignition coils |
| 5 | Trigger coil for speed signal | | |

Figure .4: Ignition circuit

7.5) Propeller gearbox

Reduction ratio

For the engine type 912 one reduction ratio is available.

Reduction ratio	912 A/F/UL	912 S/ULS
crankshaft: propeller shaft	2.27:1	2.43:1
	2.43:1 (option)	

Overload clutch

Depending on engine type, certification and configuration the propeller gearbox is supplied with or without an overload clutch.

NOTE

This overload clutch will prevent any undue load to the crankshaft in case of ground contact of the propeller.

NOTE

The overload clutch is installed on serial production on all certified aircraft engines and on the non-certified aircraft engines of configuration 3.

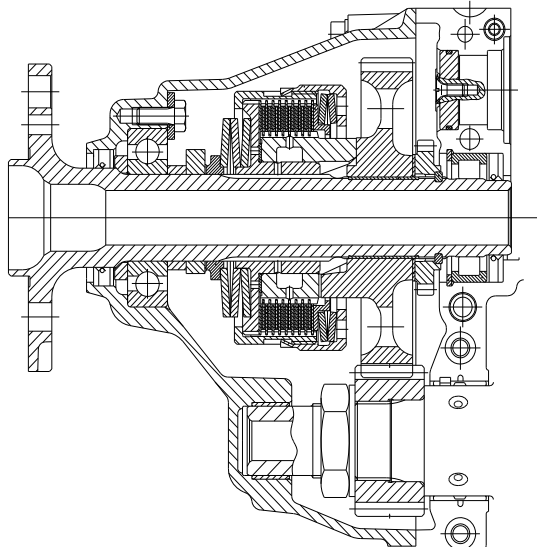

Figure .5: Overload clutch

Fig. shows a propeller gearbox of configuration 2 with the integrated overload clutch.

Torsional shock absorber

The design incorporates a torsional shock absorber. The shock absorbing is based on progressive torsional cushioning due to axial spring load acting on a dog hub.

Backlash

On the gearbox version with overload clutch the design incorporates a friction damped free play at the dogs to warrant proper engine idling. Due to this backlash at the dogs a distinct torsional impact arises at start, stop and at sudden load changes, but due to the built-in overload clutch it will remain harmless.

NOTE

This overload clutch will also prevent any undue load to the crankshaft in case of ground contact of the propeller.

See Service Letter SL-912-015

Vacuum pump or hydraulic governor

Alternatively either a vacuum pump or a hydraulic governor for constant speed propeller can be used. The drive is in each case via the propeller reduction gear.

8) Preservation and storage

Topics in this chapter

8.1 Engine preservation and storage 2

8.2 Engine back to operation 3

Safety

All checks to be carried out as specified in the current Maintenance Manual Line (last revision).

⚠ WARNING

Non-compliance can result in serious injuries or death!

Only qualified staff (authorized by the Aviation Authorities) trained on this particular engine, is allowed to carry out maintenance and repair work.

NOTE

Other useful information for service and airworthiness of your engine you'll find on

www.rotax-owner.com.

ATTENTION

Carry out all directives of Service Bulletins (SB), according to their priority. Observe according Service Instructions (SI) and Service Letter (SL).

8.1) Engine preservation and storage

⚠ WARNING

Risk of burnings and scalds! Hot engine parts!
Conduct checks on the cold engine only!

Due to the special material of the cylinder wall, there is no need for extra protection against corrosion for the ROTAX® aircraft engines. At extreme climatic conditions and for long out of service periods we recommend the following to protect the valve guides against corrosion:

Step	Procedure
1	Operate the engine until the temperatures have stabilized for a period of 5 min (engine oil temperature between 50 to 70 °C (122 to 160 °F)).
2	Switch the engine OFF.
3	Allow the engine to cool down.
4	Change oil.
5	Remove the top spark plugs and spray all openings with corrosion inhibiting oil.
6	Turn the propeller several times by hand in direction of the engine rotation, so that the corrosion inhibiting oil all necessary points reaches.
7	Install the spark plug in according the Maintenance Manual.
8	Close all openings on the cold engine, such as exhaust end pipe, venting tube, air filter etc. against entry of dirt and humidity.
9	Spray all steel external engine parts with corrosion inhibiting oil.

8.2) Engine back to operation

If preservation (including oil change) took place within a year of storage, oil renewal will not be necessary. For longer storage periods repeat preservation annually.

Step	Procedure
1	Remove all plugs and caps.
2	Clean spark plugs with plastic brush and solvent.
3	Reinstall.

NOTES

9) Supplement

Topics in this chapter

9.1 Form	2
----------------	---

See [Form](#)

According to the regulation of EASA part 21 A.3 / FAR 21.3 the manufacturer shall evaluate field information and report to the authority. In case of any relevant occurrences that may involve malfunction of the engine, the form on the next page should be filled out and sent to the responsible ROTAX® authorized aircraft engines distributor or their independent service center.

NOTE

The form is also available from the official ROTAX® AIRCRAFT ENGINES Website in electronic version.

Authorized Distributor

Overview of ROTAX® authorized aircraft engines distributor or their independent service center.
Refer to the official ROTAX® AIRCRAFT ENGINES Website
www.FLYROTAX.com.

9.1) Form

Customer Service Information Report		ROTAX [®] AIRCRAFT ENGINES	
When / Where / What			
Accident / Incident Date:		State:	
Location Of Occurrence:			
Headline:			
Narrative:			
Aircraft identification			
Aircraft registration:		Aircraft category:	
Manufacturer:		Model / Series:	
Serial number:		Aircraft total time:	
Flight details			
Flight phase:		Operator:	
Last departure point:		Planned destination:	
Engine information			
Type:		Serial number:	
Time since new [h]:		Time since overhaul [h]:	
Date overhaul:		Date inspection / maintenance:	
Propeller information			
Manufacturer:		Model / Series:	
Serial number:		Propeller position:	

Figure .1: Form

Index

A

Abbreviations	3
Abnormal operation.....	1
After engine start	8
Auxiliary equipment.....	14

B

Before engine start.....	5
--------------------------	---

C

Cold weather operation	10
Cooling system	2
Cruising	9
cylinder designation	17

D

Daily checks	2
Direction of rotation	19

E

Electric system	6
Engine back to operation	3
Engine components	17
Engine preservation and storage.....	2
Engine shut-off	10
Engine start.....	5–6
Engine views	17
Exceeding cylinder head temperature	3
Exceeding engine speed	3
Exceeding of max. admissible coolant temperature	4
Exceeding of max. admissible cooling system temperature	3
Exceeding oil temperature	4

F

Fire, Engine, compartment	5
Form.....	2
Fuel consumption	18
Fuel system.....	4

G

General.....	2
--------------	---

L

List of effective pages.....	1
Lubrication system	5

O

Oil pressure.....	5
Oil pressure below minimum.....	4
Oil pressure below minimum - on ground	5
Operating limits (912 A/F/UL).....	2
Operating limits(912 S/ULS)	5
Operating media Fuel.....	9
Operating media-Coolant	8
Operating media-Lubricants.....	10

P

Performance data	2
Pre-flight checks	5
Propeller gearbox	7

R

Re-Start during flight	3
------------------------------	---

S		
Safety notice	7, 9	
Standard version	14	
Start.....	9	
		Technical documentation
		12
		Temperature
		3
		Terms
		3
		Trouble shooting
		6
		Type description
		16

T		W
Table of amendments	1	Weight, Accessories.....
Take-off.....	9	1
Technical data	18	Weights, Engine, Accessories.....
		1

List of Figures

Figure .1:	Pos. 1: Engine serial number (1)	2
Figure .2:	Side view engine (1).....	17
Figure .3:	Top view engine (1).....	17
Figure .4:	Front view engine (1)	18
Figure .5:	Normal direction of propeller rotation (engine) (1)	19
Figure .1:	Temperature range (2)	11
Figure .1:	Expansion tank (3).....	3
Figure .2:	Overflow bottle (3)	3
Figure .1:	Performance graphs 912 A/F/UL (5).....	2
Figure .2:	Values along propeller curve (5).....	2
Figure .3:	Performance graphs 912 A/F/UL (5).....	4
Figure .4:	Performance graphs Engine 912 S/ULS (5)	5
Figure .5:	Performance graphs Motor 912 S/ULS (5)	5
Figure .6:	Performance graph (5)	7
Figure .1:	Cooling system (7).....	3
Figure .2:	Fuel system (7).....	4
Figure .3:	Lubrication system (7).....	5
Figure .4:	Ignition circuit (7)	6
Figure .5:	Overload clutch (7)	7
Figure .1:	Form (9).....	2

ROTAX®



ORIGINAL TRUST
**ROTAX
GENUINE
PARTS**
ORIGINAL QUALITY
ORIGINAL VALUE

**DON'T SETTLE
FOR LESS.**



**IN A WORLD
FULL OF FAKES,
STAY ORIGINAL.**

GENUINE PARTS

ORIGINAL QUALITY. ORIGINAL VALUE. ORIGINAL TRUST.

The high levels of safety, reliability, and performance you decided on when choosing your aircraft engine are also reflected in every single part they are built of. Find your extra peace of mind by using only Rotax Genuine Parts when your engine is serviced.

Rotax Genuine Parts are manufactured to strict quality standards for an exact fit and precise operation. They ensure that your aircraft will continue to perform at maximum levels with minimum downtime and a long service life.

Rotax Genuine Parts meet Design/Production Organisation Approval (DOA/POA) and quality standards (EASA/ASTM).

All Rotax Genuine Parts come with a coverage for the first 24 consecutive months or the first 100 hours of operation, whichever occurs first.

**There is no Rotax warranty on non-genuine parts.
If a non-genuine part causes an event on a Rotax engine,
it may nullify any warranty.**

* applies to all Rotax engine series except Rotax 582 UL

** This offer only applies if allowed under the applicable law. Some jurisdictions may not allow, or may limit, the validity of some or part of the offer; therefore conditions may vary or not be available in some locations. For more details ask your local distributor.

ROTAX®



Engine serial no.

Type of aircraft

Aircraft registration no.

Rotax® authorized distributor



FLYROTAX.COM

® and TM are Trademarks of BRP-Rotax GmbH & Co KG.

© 2016 BRP-Rotax GmbH & Co KG. All rights reserved.

