

Royal High Chair

Assembly Guide

WARNING



KEEP THIS DOCUMENT FOR FUTURE REFERENCE
 This is not a safety device
DO NOT LEAVE CHILDREN UNATTENDED EVEN WHEN HARNESS IS USED
 Incorrect installation may result in instability & weakness
 Keep plastic bags away from children
 To prevent falls, position the highchair away from solid structures
 Keep away from all dangerous items such as heat sources, liquids, window coverings, cords etc.
ONLY for use by children who are able to sit unaided
 Do not use the high chair unless all components are correctly fitted & adjusted. Check frequently
 Be aware the risk of open fire & other sources of strong heat, in the vicinity of the high chair
 Do not use the high chair if any parts are broken, torn or missing
 Always keep the tray assembled on the high chair
THE MAX WEIGHT OF THE CHILD SHOULD NOT EXCEED 35KGS

PRODUCT NOTICE



MOST INJURIES RELATED TO HIGH CHAIRS ARE CAUSED BY FALLS.
 Incidents of injuries related to the use of high chairs are substantially higher than most other products
 Assemble all components only according to TikkTakk's guidelines herein
 If harness is provided, ensure it is correctly fitted
 This high chair is made of varnished wood, as such, liquids including water, oil, wet food & drinks will damage the surface
 Wipe only with a dry or slightly damp cloth

SAFETY FEATURES



Certified toxin free
 More stable due to stronger joints
 Designed & compliant with the strict AUSSPASS standards
 Safety 5 Point harness included

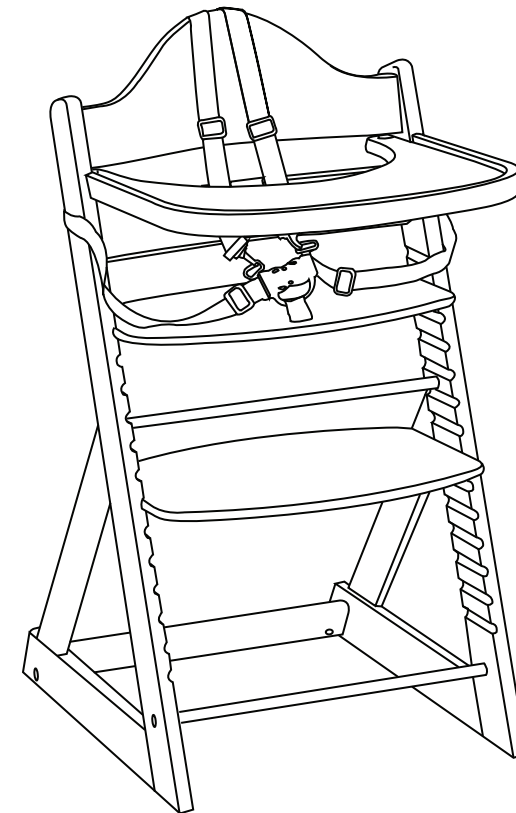

EXPORTER

TikkTakk HONG KONG
 Room 1-2-1304, Tome Mansion
 No139 Fuzhou North Rd
 266032 Qingdao
 Shandong China

CONSUMER ASSISTANCE

HOTLINE: +61 (0) 2 9980 6633
 SKYPE: tikktokk.mb
 EMAIL: info@tikktokk.com
 WEB: www.tikktokk.com
 ADDRESS: Unit 3, 280 New Line Rd
 Dural, NSW, 2158,
 Australia

IMPORTER

TikkTakk Australia
 Unit 3, 280 New Line Rd
 Dural, NSW, 2158
 Australia



IMPORTANT
 WARNINGS
 ON BACK



ASSEMBLY LEVEL



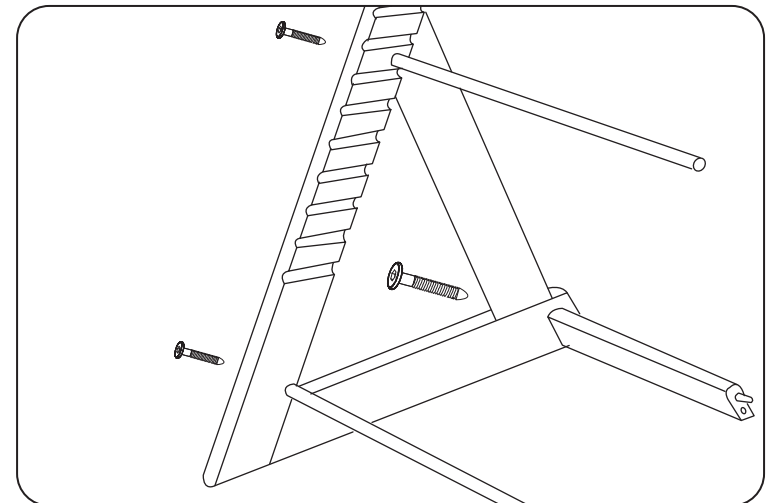
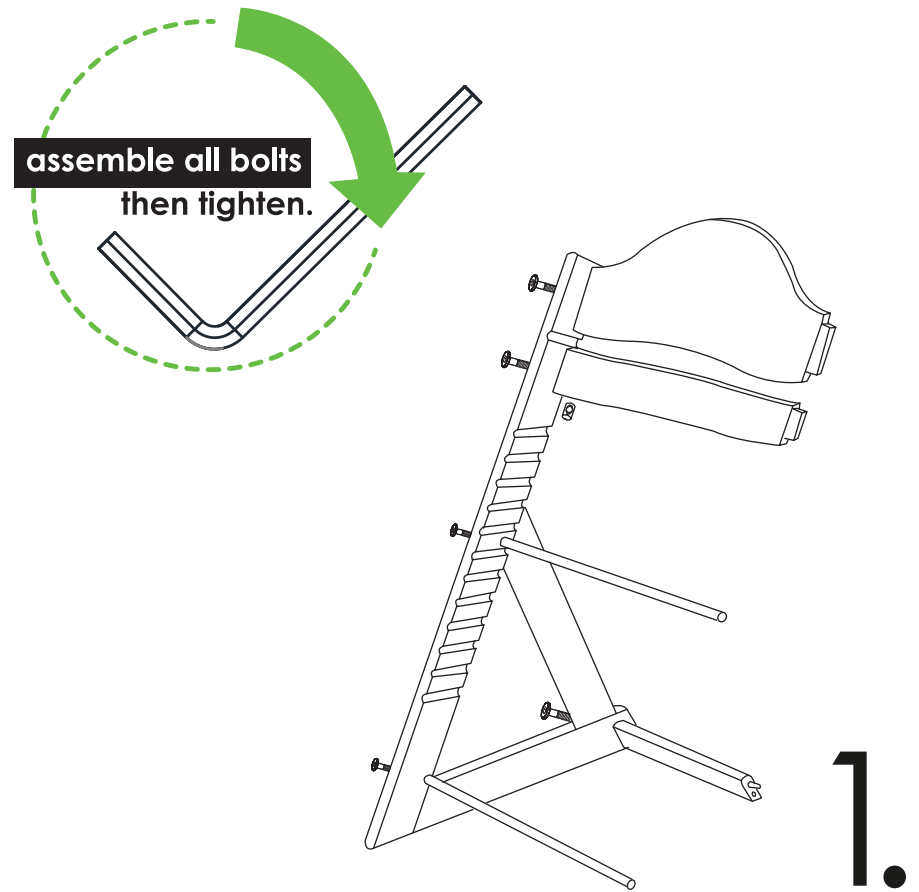
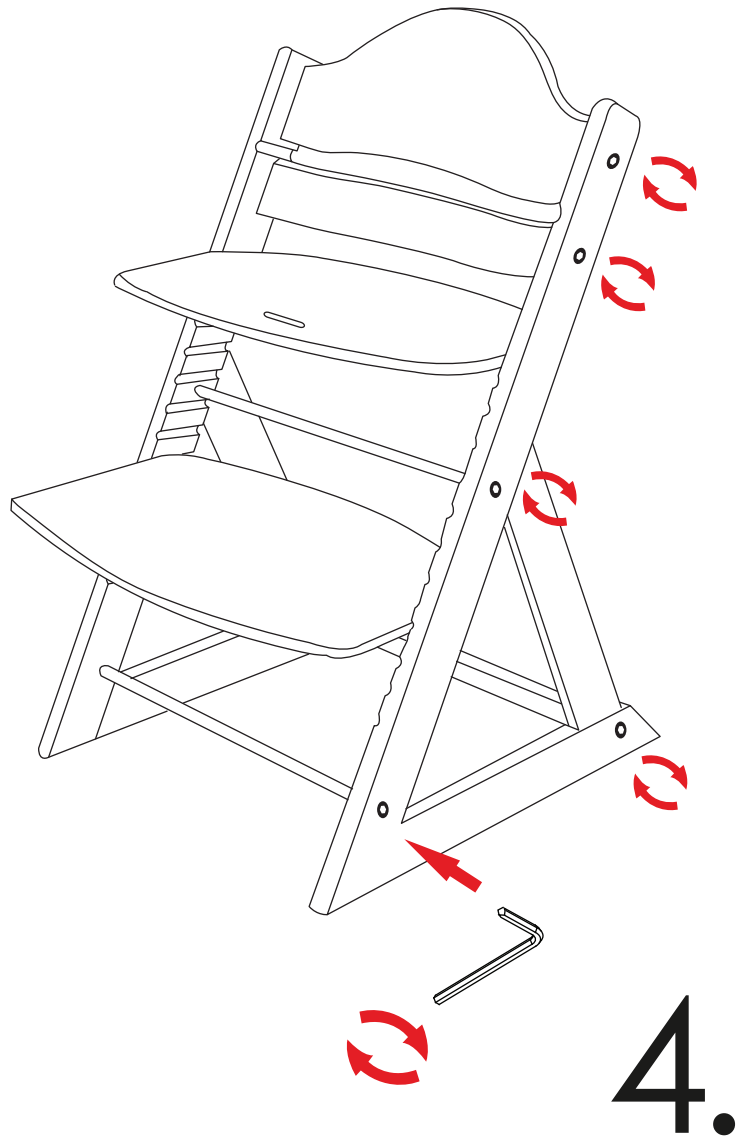

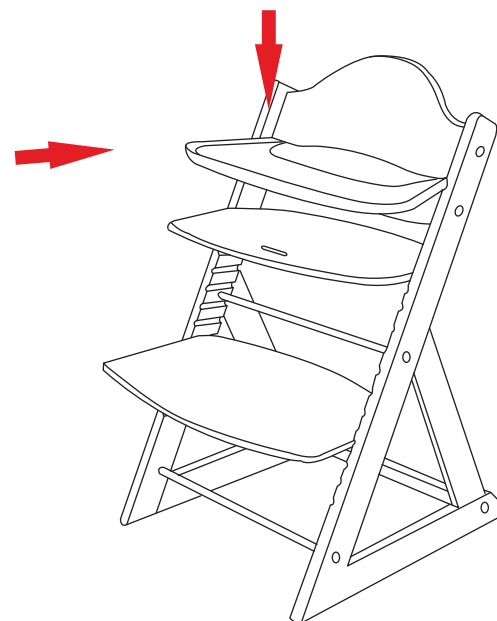
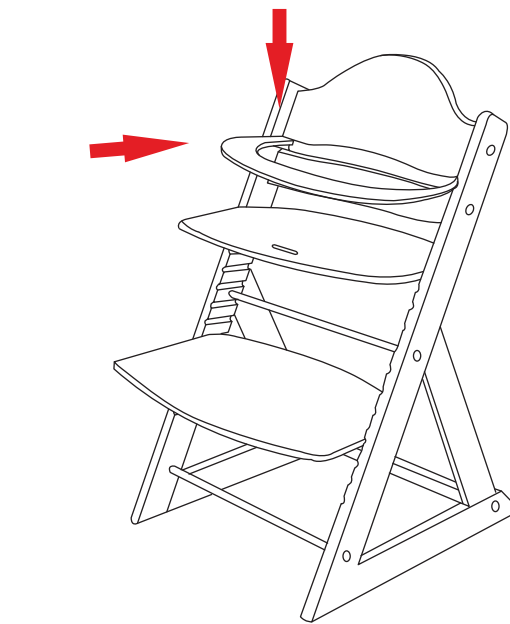
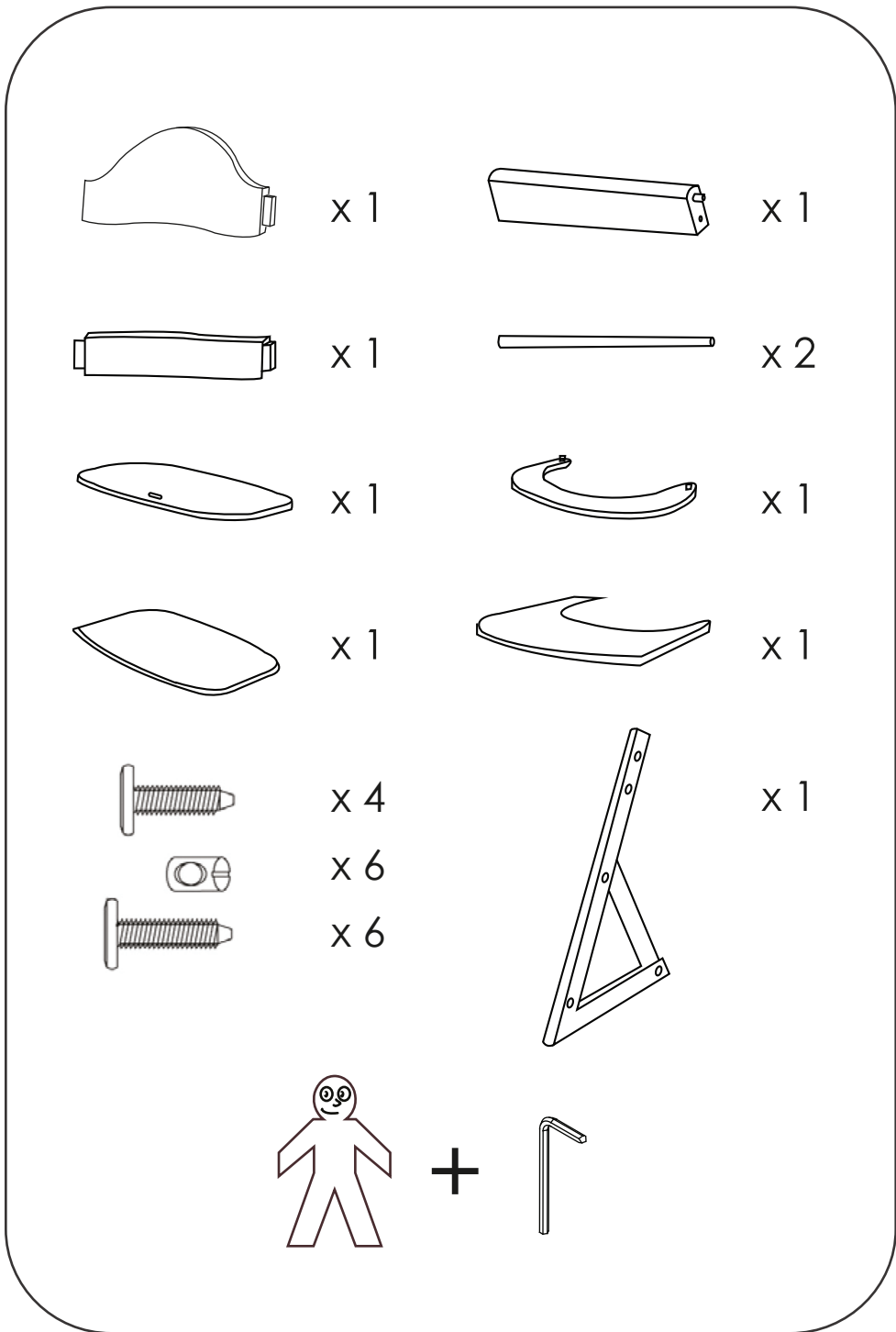

5.

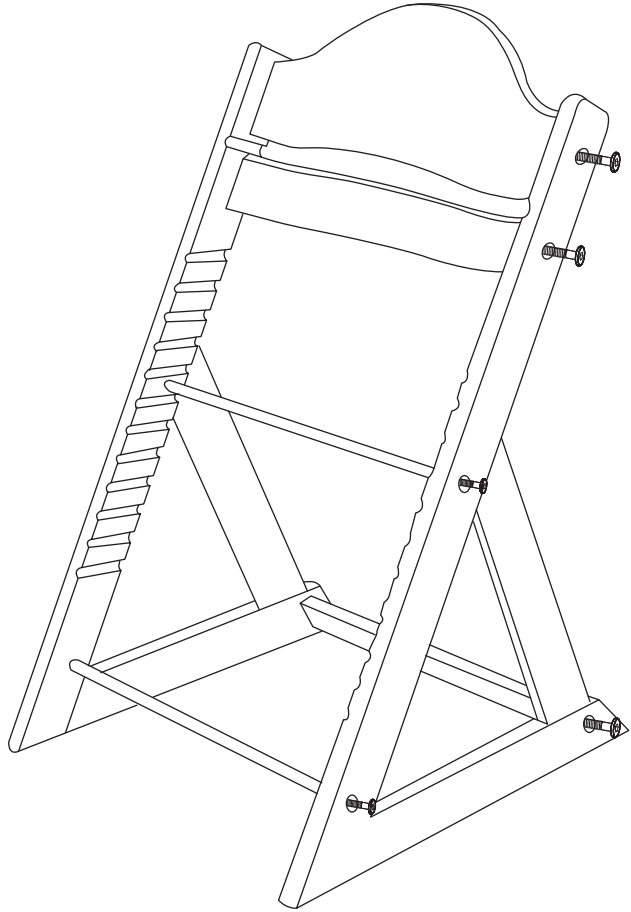

2.

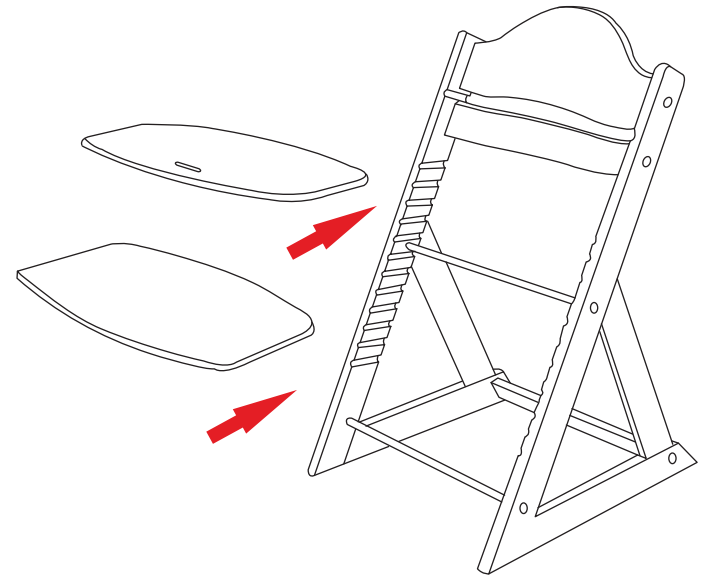

3.

