

VILLAIN[®]



SEGWAY



FEAR NO PLACE



A Villain SX10 dune buggy is shown on a sand dune. The vehicle is white with red accents and is positioned on the left side of the frame. The background consists of rolling sand dunes under a clear sky. The word "VILLAIN" is written in large, red, stylized capital letters across the middle of the image.

VILLAIN®

“Fear No Place” with the Villain SX10. Extreme performance combined with modern, aerodynamic design. Like something out of a Bond movie, the Villain boasts aggressive power & style thanks to its advanced engine, customisable ride settings and villainous looks. Equipped with remote reservoirs of both front and rear shocks, adjustable dual speed compression and rebound that can adapt to any terrain and driving style, the Villain is the ideal machine whether you’re into paddock transport, dune sprints or beach racing.

VILLAIN®



DYNAMIC POWERTRAIN

1000CC liquid cooled, twin cylinder, 4-stroke, DOHC engine delivers max 105HP and 93.5N·m of torque. The 1000CC engine adopts the optimal design of insulator spark plug and optimized CAM. With the addition of electronic fuel injection system, the powertrain has good adaptability in high/low temperature and high altitude environment.

1000cc **MAX 105HP**
93.5N-m TORQUE

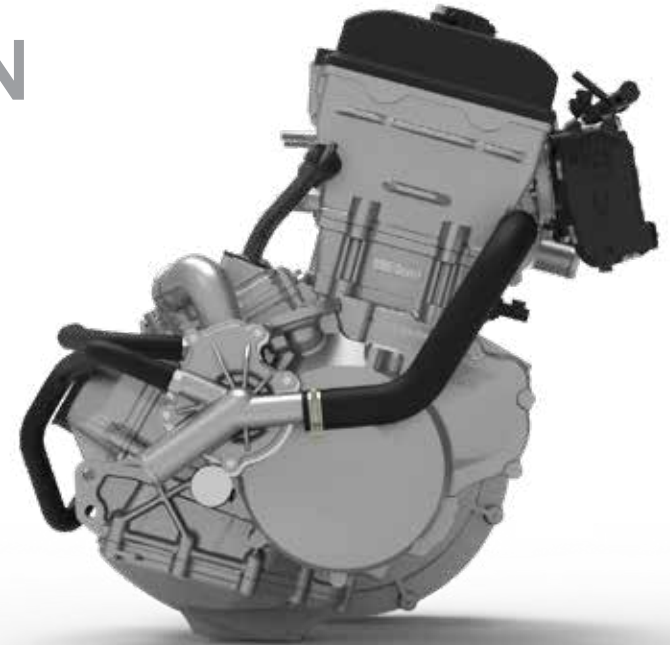

SMART MOVING & SMART FUN

SMART EPS, SMART COMMANDING SYSTEM (SCS), SMART MOVING APP

Segway's Smart EPS System is designed with standard/comfort/sport modes that will adjust automatically according to traction conditions. You can access the real-time data of your vehicle through Smart Commanding System (SCS). Add an SOS emergency contact person. In case of a serious collision/roll, the app will automatically send an SMS with location to that person.



- DRIVING SETTINGS
- WIRELESS TEAM UP
- REAL-TIME DATA
- INCIDENT - SOS
- AIRLOCK
- SECURITY



VILLAIN®





SAFETY & PERFORMANCE

Extreme Performance Gas Suspension

Remote-reservoir front and rear air shocks, with adjustable dual-speed compression and rebound. With dual A-arm, 400 mm wheel travel, plus rear suspension with 450mm wheel travel, gives you a smooth ride over the roughest terrain. From the adjustable seat and behind its inclinable steering wheel, drivers can access the LCD dashboard with adaptive display and get all the information they need in the blink of an eye.



FUEL TANK CAPACITY
44 litres

TOWWING CAPACITY
1320 kg

FRONT AUTOMATIC DIFF-LOCK WITH 2WD/4WD SWITCH

3500/4500 lb WINCH

The SX10E/SX10X come standard with a 3500lb winch, the SX10WX winch will pull up to 4500lb

Villain features a Spiral Angle Front/Rear Constant Drive Shaft, while the front axle differential enables the smooth switching between 2-wheel and 4-wheel drive. The Front axle differential lock can also be switched manually while moving, greatly improving the off-road performance.

VILLAIN[®]

SX10E



BOLD BLACK & GREEN



ELECTRIC WHITE TENSIVE O&R

SX10X



BOLD BLACK & GREEN



ELECTRIC WHITE TENSIVE O&R

VILLAIN[®]

SX10WX

BOLD BLACK & DREAM GREEN



ELECTRIC WHITE TENSIVE O&R

*SX10E SX10X**SX10WX*

DRIVE SYSTEM	POWERTRAIN	Petrol Engine	Petrol Engine
	DISPLACEMENT	1000cc, 4-Stroke Twin-Cylinder, DOHC Engine	1000cc, 4-Stroke Twin-Cylinder, DOHC Engine
	MAX TORQUE	93.5 N.m	93.5 N.m
	HORSEPOWER	105 hp	105 hp
	COMPRESSION RATIO	10.6	10.6
	FUEL SUPPLY	Electronic Fuel Injection	Electronic Fuel Injection
	FRONT AXLE	Switchable Diff-Lock	Switchable Diff-Lock
	DRIVE SYSTEM	On-Demand 2WD / 4WD	On-Demand 2WD / 4WD
	SMART ELECTRONIC POWER STEERING (EPS)	Three Modes: Standard / Comfort / Sport	Three Modes: Standard / Comfort / Sport
	COOLING SYSTEM	Duel Oil Column Piston Cooling System + Liquid & Oil Heat Exchanger Cooling System	Duel Oil Column Piston Cooling System + Liquid & Oil Heat Exchanger Cooling System
SUSPENSION	FRAME	High-strength chromium-molybdenum steel frame	High-strength chromium-molybdenum steel frame
	REAR SUSPENSION & TRAVEL	Multi-link Trailing-Arm with Stabilizer Bar, Travel: 450mm	Multi-link Trailing-Arm with Stabilizer Bar, Travel: 450mm
	FRONT SUSPENSION & TRAVEL	Dual A-Arm with Stabilizer Bar, Front 400mm	Dual A-Arm with Stabilizer Bar, Front 400mm
	SHOCK	Remote Reservoir Gas Shock	Remote Reservoir Gas Shock
	TYRES	Front Tyres 6 Ply 29 x 9-14 Rear Tyres 6 Ply 29 x 11-14	Front Tyres 6 Ply 30 x 10-14 Rear Tyres 6 Ply 30 x 10-14
	WHEELS	SX10E Aluminium SX10X Aluminium with Beadlock Device	Aluminium with Beadlock Device
	BRAKES	Four-wheel Hydraulic Disc Brake	Four-wheel Hydraulic Disc Brake
DIMENSIONS	WINCH CAPABILITY	35001b (1587.6kg)	4500 lb (2041kg)
	PAYLOAD CAPACITY	198.4+374.81b (90+170kg)	198.4+374.81b (90+170kg)
	TOWING CAPACITY	2910 lb (1320kg)	2910 lb (1320kg)
	FUEL CAPACITY	11.6 gal (44L)	11.6 gal (44L)
	DRY WEIGHT	1840.91b (835kg)	1885.0lb (855kg)
	SEAT HEIGHT	23.7" (60cm)	23.7" (60cm)
	WHEELBASE	102"(259cm)	102"(259cm)
	GROUND CLEARANCE	14.2"(36cm)	14.6"(38cm)
	VEHICLE SIZE	132.9 x 64.2 x 70.9" (337.5 x163.0 x180.0 cm)	132.3 x 72.8 x 72.8"(338.0 x185.0 x185.0 cm)



SX10E

SX10X

SX10WX

RIMS	14"	14"	14"
TYRES	6 PLY 29"	6 PLY 29"	6 PLY 30"
SHOCKS	GAS	GAS	GAS
WINCH	3500LB	3500LB	4500LB
DOORS	1/4	1/4	1/4
SEATS	2	2	2
TRANSMISSION	CVT	CVT	CVT
T-BOX SMART FEATURE	✓	✓	✓
4 WHEEL DISC BRAKES	✓	✓	✓
HITCH & MOUNTING BALL	✓	✓	✓
SWITCHABLE FRONT DIFF-LOCK	✓	✓	✓
HARD ROOF	✓	✓	✓
FRONT BUMPER	✓	✓	✓
LED LIGHTING	✓	✓	✓
SMART EPS	✓	✓	✓
10.4" TOUCHSCREEN	✗	✓	✓
BEADLOCK RIM	✗	✓	✓



FEAR NO PLACE



Founded in 1999 by Dean Kamen in the USA, Segway Brand (hereinafter referred to as "Segway Powersports") is an innovative company in the field of design and manufacturing, included but not limited to: Quad Bikes, Utility Side by Sides, Sport Side by Sides and On-road vehicles. Approaching the international market from a long-term perspective, Segway Powersports has numerous self-developed patented designs including a hybrid powertrain, internal combustion engines, a smart IOV system, advanced vehicle designs etc. Segway Powersports is a high-tech enterprise integrating a superior supply chain and its own factories. The company specializes in the R&D, production, sales and after-sales service of Powersports products. Segway Powersports adheres to the motto of "FEAR NO PLACE" and aims to be the leading on and off-road mobility solution provider. Segway Powersports is a subsidiary of the Segway-Ninebot Group which is a unicorn in the global smart mobility industry. Segway-Ninebot has three major business regions including Asia-Pacific, Europe and America, and its products are sold in more than 100 countries and regions around the world. It owns over 1,000 global core patents. By meeting the diverse, cool and fun needs of users, Segway-Ninebot continues to lead the industry with its new product development.



Dealership details:



www.segwaypowersports.com.au
www.segwaypowersports.nz

Overseas models may be shown with accessories that are not standard fitment. Segway Powersports Australia & New Zealand reserves the right to vary colours, specifications and pricing at any time. Apply for finance or order online today to pick up from your nearest Segway Powersports dealer.