



SM1250+
Ride-On Sweeper
USER MANUAL

SM1250 + Ride-On Sweeper User Manual



- Thanks for choosing our S M 1250 + electric ride-on sweeper.
- Please read this instruction carefully before use, and use it correctly and safely.
- After reading, please keep the instruction manual properly for reference.
- Due to the continuous improvement of our products, we are sorry for any change without prior notice.

Security:

The following symbols indicate potential hazardous conditions. It is particularly important to read the instructions with regard to necessary measures of precaution and protection.

The essence of the manual is to prevent the danger of accidents, and most of accidents are occurred during to carelessness about safety operation rules. The best guarantee of getting away from accidents is that the users are careful and cautious, which is better than other prevention. Be careful to your surrounding and people around, especially children, when using the sweeper.

Symbol instructions:



Danger! Means: the situation is dangerous to the operator.



Warning! Means: the potential possibility may cause harm to the user.



Take care! Means: be careful or important related notes, especially these signs in paragraphs.



Notice ! Means: important or useful function.



Consult ! Means: must read user manual before operation.

General Instruction:



Danger!

1. Be sure to turn the power off and meanwhile take off the key from power switch before any maintenance.
2. Be sure to operate by professionals who are specialized trained when using the sweeping machine. It is strictly prohibited to operate by non-professional personnel.
2. No drunken driving, don't bring accessories and don't wear long scarf, try to wear uniform to work.
3. Don't use in such dangerous places which include explosive gas, liquid water and vapor.
4. Ensure the battery in a ventilated zone when charging . It shall promptly charge the battery

when the machine stops working or appearing low voltage alarm during run-time, and at the same time, keeping the lid open, getting away from the fire, both of which would prolong the life of the battery and security.

5. the reason why it is strictly prohibited to cleaning the wire rope, belts, high temperature sundry, water, flammable or poisonous and harmful material is to avoid the winding, burning the main brush and the side brush, to make it can't work normally.

6. It is prohibited driving in more than a steep slope or high-speed road meanwhile be careful with sharp corners.

7. When the machine works, we should control the work speed less than 5km/h, and vibrate dust every 30-45 minutes so as to achieve the best of cleaning effect.

8. Turn off the power after using and then try to put it in the house, store or flat place.



Warning!

1. Please read the maintenance instructions before any maintenance and repair operations.

2. Please keep your loosen clothing, hair, fingers and any part of the body away from air inlet of machines and any moving parts.

3. Battery charger should get far away from high heat place.

4. Connecting the battery charger to the trunk circuit while ensuring the voltage and frequency consistent with parameters of charger nameplate signs.

5. Don't charge the battery if battery charger cable is damaged or battery immersion, besides, damaged machine is also included.

6. The wire of battery charger shall not be used by pulling the machine and meanwhile don't regard charger wire as the handle.

7. Don't open voltage switch and start operation during battery charging period.

8. Please don't be placed in the open air so as to avoid electric shocks.

9. Don't treat the machine as a toy; especially pay attention to keep the children far away.

10. Remember to take off the key when the machine stops.

11. Don't drive on the steep slope which is far from its limit.

12. If the thickness of roads waste is more than 2 millimeter, please adjust the running speed of the machine according to adhesion of the ground garbage, and then repeat cleaning operation.

13. Don't put the cup or the bottle with other liquid water on the machine.

14. The operation duration shall not exceed 30 minutes when the temperature is 40 degrees or above. At this time, the machine is not only vibrated dust and cleaned dirt, but also rest for 5-15 minutes and then for the next operation.

15. Never put the machine as a means of transport.

16. When the machine is not working, stop rolling the brush to avoid to wear brush, leading to affect the used life

-
17. Once fire, don't put out the fire with water just use the power fire extinguisher.
 18. Don't bump the dangerous shell on which may drop down items.
 19. Don't change safety protection device of the machine. Execute according to the maintenance program.

Battery safety requirement

1. The battery is not allowed to work in a low voltage state, charge the battery immediately once the low voltage alarms.
2. Free maintenance battery and no need of adding electrolyte.
3. To avoid leakage, please keep the battery dry; clean, especially to avoid erosion of pollutants like metal powder.
4. The metal part such as the tool is banned to place on the battery so as to prevent burning out the short-circuited battery.
5. When the battery is recycling please implement according to the local regulations.
6. The fire is prohibited to use when you hand or process the battery.
7. The charging room should be well ventilated.
8. When the key switch is in the on position, it is not allowed to connect or disassemble the battery.

Before Operation



Be careful!

1. Check whether the parts of machine are damaged during transit movement.
2. Close both sides of the plates and the front box cover, tighten the dustbin hook and make sure that the machine can work normally.

Start Operation

1. Driving mode

- A.** Fasten seat belt.
- B.** Ensure that the side brushes and the main brushes are in raised position.
- C.** Insert the key and turn on
- D.** Forward/backward switch: put forward button, step the accelerator pedal, the sweeping machine can drive forward. On the contrary, put backward button, step the accelerator pedal, the machine drives backward.

2. Cleaning mode

A. When you press the sweep button, the main brushes and side brushes get down and clean automatically.

B. Press the sweep button after finishing sweeping; the main brushes and side brushes are automatically lifted and stop rotating .

C. If you need cleaning the large garbage such as a stick, cigarette case, step large junk pedal, and drive to the clean area in a low-speed , the main brush can sweep the large garbage into the dustbin.

D. If the working environment is relatively bad, stop sweeping after intervals meanwhile turn on the vibration switch to vibrate dust.

E. Check the garbage and empty the dustbin in time



Notice: wire rope, belts and similar garbage is forbidden to sweep.

3. Drive through the barriers

A. the height of the barrier is less than 6 cm

The sweeper can pass safely. Touch the governor pedal before driving .

B. the height of the barrier is more than 6 cm

Get passing after inclined plane.

Stop Operation

1. Loosen accelerator pedal

2. Turn the key off

3. Press brake pedal and then pull the handbrake lever

Empty the dustbin

1. Stop and clean filter .

2. unlock buckle of dustbin

3. Pull the dustbin downward, then drag out to empty.

4. Put the dustbin back inside the machine and fasten the locking buckle of dustbin.

5. Finish routine examination for the next work.

6. Push or drag machine

After operation

Please perform the operation before leaving the machine when finish working.

1. Press the sweep button to raise the main brushes and side brushes.

2. Press the filter-cleaning button to vibrate and turn off after 15minutes.

3. empty the dustbin

4. Turn off the power and take off the key.

5. Pull handbrake lever

If you don't use the machine for a long time (at least 15 days)

Please do as follow:

1. Check and keep the machine dry
2. Disconnect the battery terminal, recharge at least one time per month

Repair and maintain machines

1. The machine maintenance shall be according to correct routine.
2. Perform strictly according to the maintenance schedule.

3.  **Warning!**

4. Perform maintenance operation after stopping the machine, (pulled out the key), remove battery when necessary, please read the instructions carefully about safe sections.

Maintenance schedule

Maintenance operation	Before first using	Every 10 hours	Every 50 hours	Every 100 hours	Every 200 hours	Every 400 hours
Check the height of side brushes and main brushes by adjusting						
Whether main brushes and side brushes are winded by the cable or wire material						
Check whether the garbage filtering is cleaned completely						
Trial operation and check isolate leather						
Oil lubrication point						
Check the vibration filter						
The drive belt of main brushes						
Check screws or Screws cap being tightened						
Check the brake pedal						
Check wear and tear conditions of main brushes and side brushes						
Replace the drive belt of main brushes						
Check and replace Main brushes and drive system carbon brushes						

Note: The interval time of the maintenance can be changed, but it has to be decided by the professional personnel who are responsible for maintenance.

i Notice: Check the pressure of the main brushes on the ground

Check whether the brush is in the right position , the process is as follows:

1. Operate the machine on the flat road.
2. Keep the main brush stop and rotate for a few second.
3. Check the trace of the main brush, along which you need to see whether the length is 2-4 cm, if not, adjust the pressure between brushes and ground. The screw is used to adjust the height of main brushes from the ground.
4. Please replace when the brush is abrasion, must be adjusted.

i Be careful! The normal operation of the machine will be affected if the trace of the brush is more than 5cm, and spare parts will be hot, therefore shorten service life of the machine.

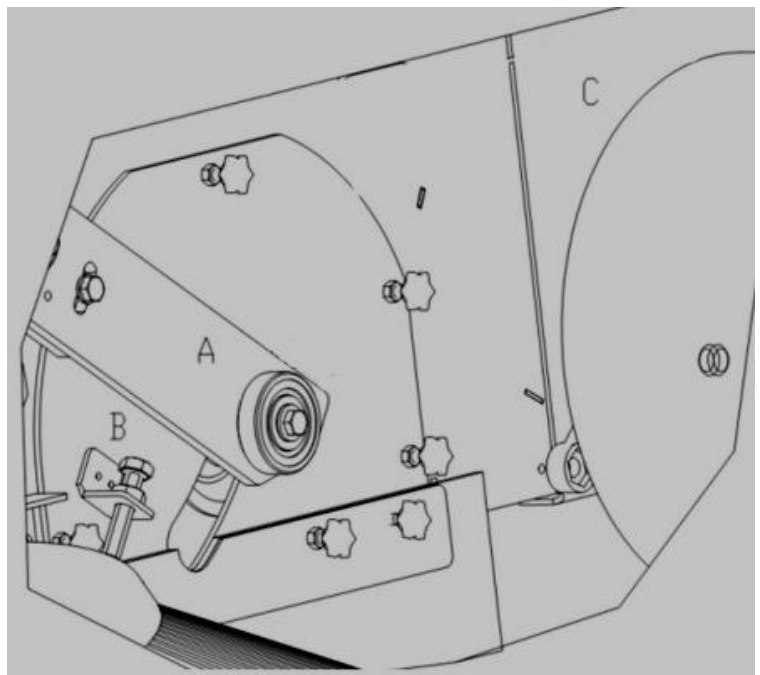
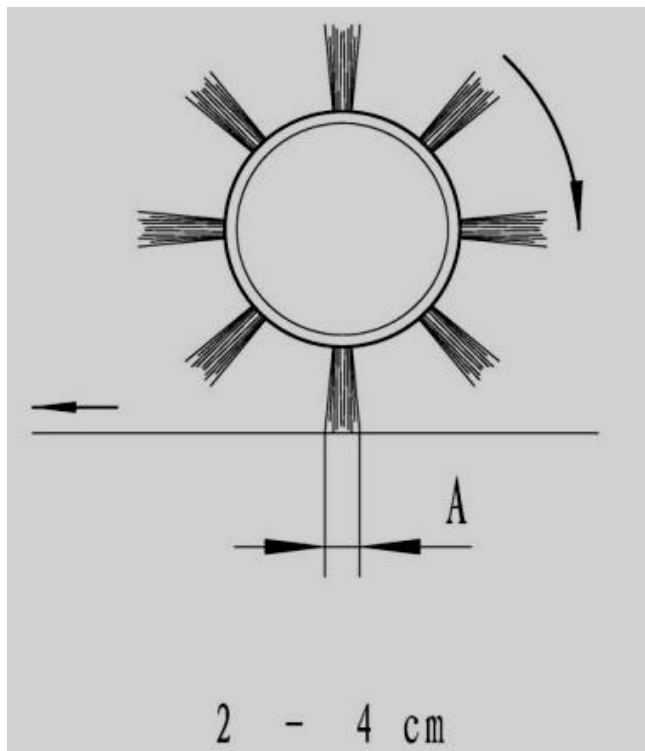

Replace the main brush

! Be careful!

Please wear gloves to prevent being scratched when replacing main brushes.

1. Park machine on flat ground, pull handbrake lever
2. Stop sweeping function.
3. Turn off the key
4. Open left side door (Picture 9)
5. Screw off B
6. Screw off 1、 2、 3, and pull out A.
7. Screw off 4、 5、 6、 7 nut, pull out isolation leather.
8. Screw off 8、 9、 10、 11、 12 nut , pull out round plate
9. Remove broom A.
10. Check if there is any rope inside
11. Install new main brush like picture 10.
12. Install round plate and nuts
13. Close left side door.
14. Check and adjust the height of main brush .

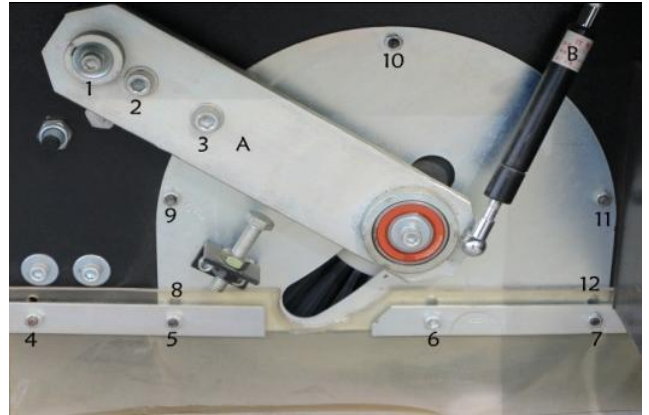

Picture 8

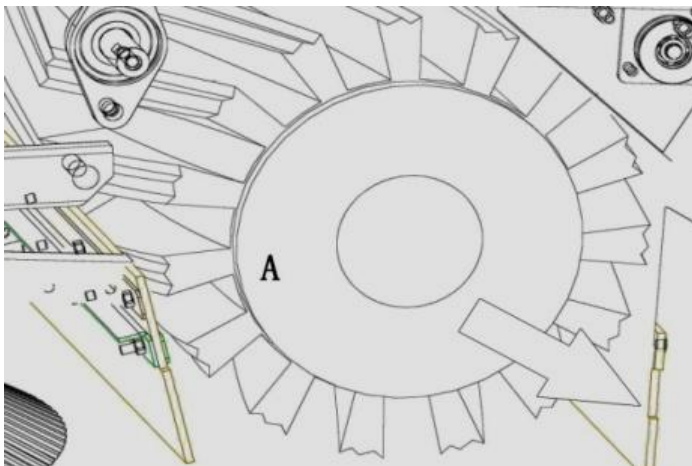

Picture 9

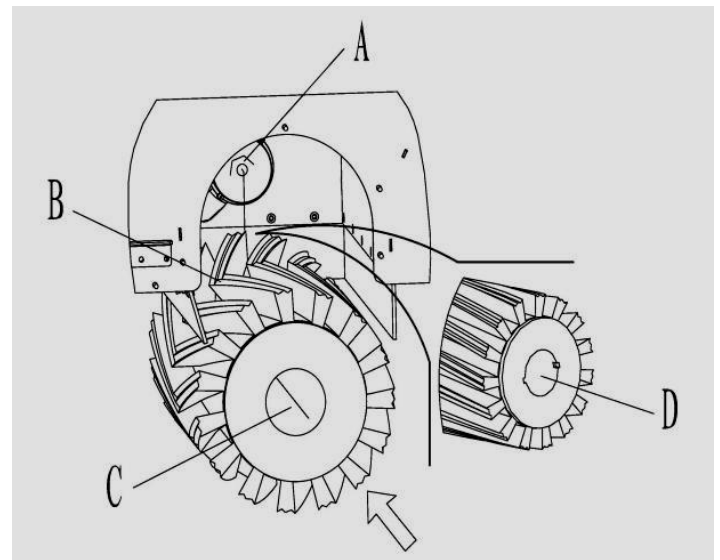

Picture 10

i Notice: Check and adjust the height of side brushes

1. Check side brush height by follow procedure:
 - A. Operate the machine on the flat road.
 - B. Keep the machine stop and run side brush for a few second.

- C. Rise side brush, move the machine and then stop the machine
- D. Check the cleaning trace of side brush according to picture 11 (A and B).
- If the cleaning trace is not within normal limits, adjust the height.

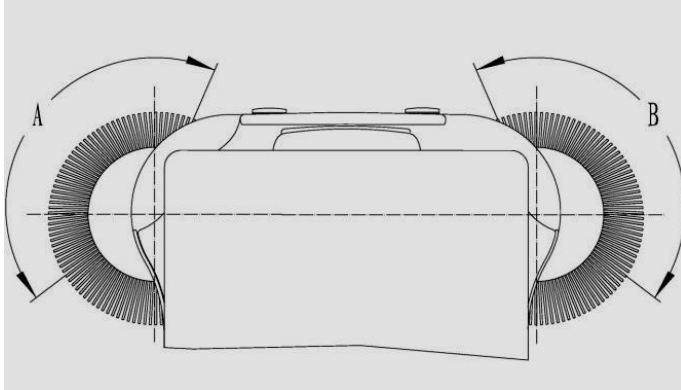

Picture 11

2. Press brake pedal, pull handbrake lever
3. Turn off key
4. Open left side door
5. Adjust bolt A to make B fall to suitable position (Picture 12)
6. Lock bolt B
7. Check brush side again
8. If the brush is abrasion, need to change .

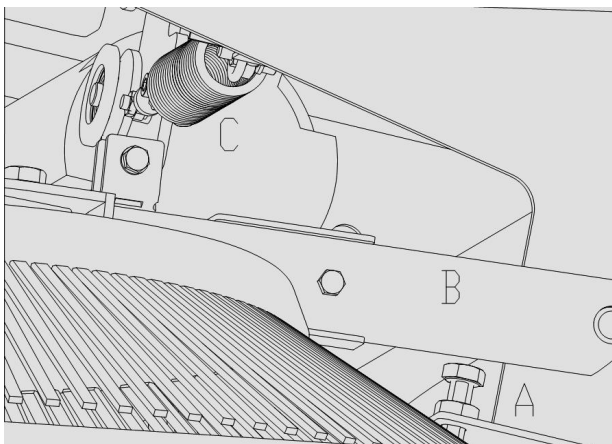

Picture 12

Replace side brush



Be careful!

Please wear gloves to prevent being scratched when

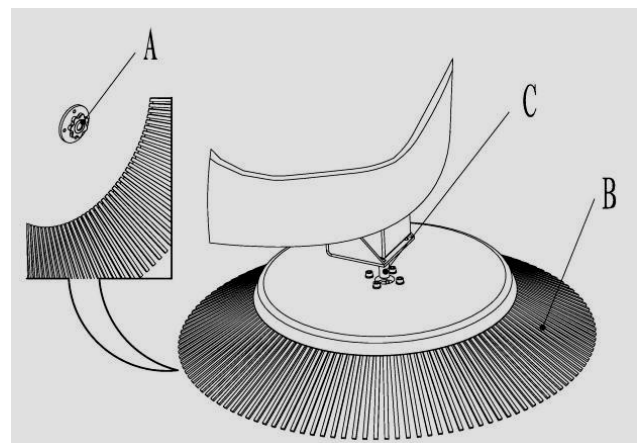

Picture 13

replacing side brushes.

1. Park machine on flat ground, pull handbrake lever
2. Turn off key
3. Screw off nut A (Picture 13), and press brush to remove it
4. Change new one and tight nut A
5. Check and adjust side brush height.

Check and Clean filter



Be careful!

Please wear gloves to prevent being scratched when replacing side brushes.

1. Park machine on flat ground, pull handbrake lever
2. Turn off key
3. Screw off 8 nuts of vibration dust cover
4. Pull out the filter
5. Clean filter by compressed air (max 6 bar, picture 15)
6. Check if there is any crack, if do , change new one
7. Install again



Picture 15

Machine fault and troubleshooting

Problem	Possible Reason	Solution
The key on “on” position, but the machine doesn’t move	Battery wire broken	Connect wire again
When press accelerator pedal, the machine don’t move	Handbrake is working	Loosen handbrake
	Travel switch broken	Change travel switch
Main brush don’t work	Contactora is not connected	Reset contactora
Side brush don’t work	Main brush doesn’t get down	Bring down main brush
	Contactora is not connected	Reset contactora
The sweeper only sweep when it doesn’t move, or the battery indicator shows less than 4 red grid (Low power)	Battery no power	Charge battery . If still have problem, suggest to change new battery
Low battery	Exceed battery life	Change battery
	Battery broken	Repair or change battery
Note: Other problem please connect us for identify.		